

# İçindekiler

## Index

### Inhaltsverzeichnis



<b>Genel Bilgiler</b> <i>General Info.</i> Einführung	<b>Sembollerin Açıklaması</b>	<i>Key of Symbols</i>	Erklärung der Bezeichnungen	03
	<b>Ürün Yelpazesi</b>	<i>Production Range</i>	Produktpalette	04
	<b>K Serisi Redüktörlerin Genel Özellikleri</b>	<i>General Specifications of K Series Gearboxes</i>	Allgemeine Eigenschaften Von K Serie Getrieben	06
	<b>Teknik Tanımlamalar</b>	<i>Technical Explanations</i>	Technische Erläuterungen	07
	<b>Teknik Özellikler</b>	<i>Technical Specifications</i>	Technische Informationen	07
	<b>Aksesuarlar</b>	<i>Accessories</i>	Zubehör	08
	<b>Yüzey Koruması</b>	<i>Surface Protection</i>	Oberflächenschutz	08
	<b>Tip Tanımlaması</b>	<i>Unit Designation</i>	Typenbezeichnungen	10
	<b>Örnek Tip Tanımlamaları</b>	<i>Sample Designations</i>	Typenbezeichnungsbeispiele	13
	<b>Motor Büyüklüğüne Göre Geometrik Mümkün Çevrim Oranı Komb. Servis Faktörü</b>	<i>Geomet. Possible Combinations of Ratios According to Motor Size</i>	Geomet. Mögliche Kombi. von Übersetz. nach Motorbaugröße	14
	<b>Yük Sınıflandırması</b>	<i>Load Classification</i>	Belastungsart	17
	<b>Redüktör Dönüş Yönleri</b>	<i>Direction of Rotation</i>	Getriebedrehrichtungen	19
	<b>Radyal Yükler</b>	<i>Overhung Loads</i>	Querkräfte	20
	<b>Radyal Yüklerin Hesabı</b>	<i>Calculation Of Overhung Loads</i>	Berechnung der Querkräfte	21
	<b>Ekstruder Tiplerde Müsade Edilebilir Eksenel Yükler</b>	<i>Permissible Axial Loads for Extruder Types</i>	Zulässige Axialkräfte für Extruder Typ Getrieben	22
	<b>Eşdeğer Güç Hesabı</b>	<i>Equivalent Power Calculation</i>	Äquivalente Leistung	24
	<b>Eşdeğer Güç Hesabı Örneği</b>	<i>Equivalent Power Cal. Example</i>	Beispiel für Äquivalente Leistung	25
	<b>Redüktör Seçimi</b>	<i>Gearbox Selection</i>	Getriebeauswahl	26
	<b>Redüktör Seçim Formu</b>	<i>Gearbox Selection Form</i>	Formular für Getriebeauswahl	28
	<b>Yağlama</b>	<i>Lubrication</i>	Schmierung	31
	<b>Genleşme Tankı</b>	<i>Expansion Tank</i>	Ölgleichsbehälter	32
	<b>Yağ Tipleri</b>	<i>Oil Types</i>	Schmierstoffe	33
	<b>Montaj Pozisyonları</b>	<i>Mounting Positions</i>	Bauformen	34
	<b>Yağ Tapaları</b>	<i>Oil plugs</i>	Ölverschlussschrauben	35
	<b>Yağ Miktarları</b>	<i>Oil Quantities</i>	Ölmengen Tabellen	35
<b>Motorlar</b> <i>Motors</i> Motor	<b>AC Motorlar</b>	<i>AC Motors</i>	Drehstrommotoren	39
	<b>a- Genel Özellikler</b>	<i>a- General Spec. of AC Motors</i>	a-Eigensch. des Drehstrommotors	39
	<b>b- Çalışma Türleri</b>	<i>b-Modes of Operation</i>	b-Betriebsarten	40
K0801-1016	<b>c- Koruma Sınıfı</b>	<i>c- Protection Class</i>	c- Schutzarten	41
	<b>d- İzolasyon Sınıfı</b>	<i>d- Insulation Class</i>	d- Isolationsklasse	41

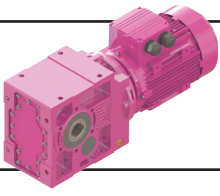

# İçindekiler

## Index

### Inhaltsverzeichnis



	<b>e- Verim Sınıfları</b>	<i>e- Efficiency Classes</i>	e- Energieeffizienzklassen	41
<b>Motorlar</b> <i>Motors</i> Motor	<b>f- AC Frekans İvertörler</b>	<i>f- AC Frequency Inverters</i>	f- AC Frequenz Umrichter	42
	<b>DC Motorlar</b>	<i>DC Motors</i>	DC Motoren	
	<b>a- Genel Özellikler</b>	<i>a- General Specif. of DC Motors</i>	a- Eigenschaften von DC Motoren	43
	<b>b- DC Motorların Çalışma İlkeleri</b>	<i>b- Operating principals of DC Motors</i>	b- Funktionsprinzip der DC Motoren	43
	<b>c- DC Motor Çeşitleri</b>	<i>c- Types of DC Motors</i>	c- Arten von DC Motoren	43
	<b>d- DC Motorlarda Hız Kontr.</b>	<i>d- Speed Control of DC motors</i>	d- Drehzahl Kontrolle DC Motoren	43
	<b>Elektromanyetik Frenler</b>	<i>Electromagnetic Brakes</i>	Elektromagnetische Bremsen	44
<b>Frenler</b> <i>Brakes</i> Bremsen	<b>Fren Çeşitleri</b>	<i>Brake Types</i>	Bremsenarten	45
	<b>Fren Bağlantı Şekli</b>	<i>Connection Types</i>	Schaltungsarten	46
	<b>Fren Seçimi</b>	<i>Brake Selection</i>	Bremswahl	46
	<b>Frenin Termik Kapasitesi</b>	<i>The Thermal Capacity of Brake</i>	Therm. Kapazität der Bremsen	47
<b>Güç Devir Tabl.</b> <i>Perform. Tables</i> Leistung-Drehzahl Tabellen.	<b>Motorlu Güç Devir Tabloları</b>	<i>Geared Motors Performance Tables</i>	Getriebsmotoren Leistung und drehzahl Übersicht	49
	<b>Motorsuz Güç Devir Tabloları</b>	<i>Gear Units Performance Tables</i>	Getriebe Leistung und Drehzahl-übersicht	363
<b>Ölçü Sayfaları</b> <i>Dimension Pages</i> Abmessungen Tabellen	<b>KR serileri</b>	<i>KR series</i>	KR serie	85
	<b>KN serileri</b>	<i>KN series</i>	KN serie	178
	<b>KV serileri</b>	<i>KV series</i>	KV serie	270
	<b>KT serileri</b>	<i>KT series</i>	KT serie	373
<b>Mil ve Kovan Ölçüleri</b> <i>Shaft and Hollow Shaft Dimensions</i> Wellen und Gehäusemaße	<b>K...0E Ekstruder Boğazlı Redüktörler</b>	<i>K...0E Extruder Type Gearboxes</i>	K...0E Extruder Getriebe von K Serie	466
	<b>K...0S Sıkma Bilezikli Redüktörler</b>	<i>K...0S Gearboxes with Shrink Disk Connector</i>	K...0S Serie Hohwelle mit Schrumpfscheibe	470
	<b>K serisi Kovan Ölçüleri</b>	<i>K series Hollow Shaft Dimensions</i>	Gehäuseabmessungen von K Serie Getriebe	471
	<b>Moment Kollu Redüktörler</b>	<i>Gearboxes with Torque Arm</i>	Drehmomentstütze Montagezeichnungen	471
	<b>K Serisi Redüktörler için Montaj Önerileri</b>	<i>Mounting Advices for Hollow Shaft Gearboxes</i>	Montagevorschläge Für D Serie Getriebe	474
<b>Motorlar</b> <i>Motors</i> Motor	<b>Elektrik Motorlarının Performans Değerleri</b>	<i>Electric Motors Ratings and Performance</i>	Elektromotoren Leistungsdaten	475

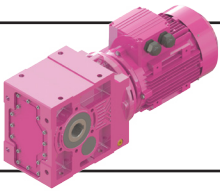

# Genel Bilgiler

## General Information

### Einführung



#### Sembollerin Açıklaması

$c_t$ .....: Anahtarın devreye girme zamanı katsayısı

$f_s$ .....: Servis faktörü

$F_{ama}$ .....: Çıkış milinde müsaade edilen eksenel yükler [kN]

$F_{ame}$ .....: Giriş milinde müsaade edilen eksenel yükler [kN]

$F_{qam}$ .....: Çıkış milinde izin verilen radyal yükler [N]

$F_{qem}$ .....: Giriş milinde izin verilen radyal yükler [N]

$F_{qa}$ .....: Çıkış miline gelen radyal yükler [N]

$F_{qe}$ .....: Giriş miline gelen radyal yükler [N]

$F_q$ .....: Radyal yönde çıkış miline gelen yükler [N]

$F_a$ .....: Eksenel yönde çıkış miline gelen yükler [N]

$i$ .....: Tahvil oranı

$J_{ext}$ .....: Motor miline indirgenmiş toplam dış atalet momenti [kgm<sup>2</sup>]

$M_2$ .....: Çıkış momenti [Nm]

$M_a$ .....: Anma momenti [Nm]

$n_1$ .....: Redüktör giriş mili devri [d/dak]

$n_2$ .....: Redüktör çıkış mili devri [d/dak]

$P_{eq}$ .....: Eşdeğer güç [kW]

$P_e$ .....: Nominal güç (Bak. Güç-Devir Tabloları) [kW]

$P_M$ .....: Tahrik edilecek makina için gerekli güç (Değişken yükler için eşdeğer güç alınır) [kW]

$t$ .....: Zaman [s]

$T_e$ .....: Eşdeğer moment [Nm]

#### Key of Symbols

$c_t$ .....: Coefficient of switch on time.

$f_s$ .....: Service factor

$F_{ama}$ .....: Permissible axial loads which can be applied to output shafts [kN]

$F_{ame}$ .....: Permissible axial loads which can be applied to input shafts [kN]

$F_{qam}$ .....: Permissible overhung loads which can be applied to output shafts [N]

$F_{qem}$ .....: Permissible overhung loads which can be applied to input shafts [N]

$F_{qa}$ .....: Overhung loads applied to the output shaft [N]

$F_{qe}$ .....: Overhung loads applied to the input shafts [N]

$F_q$ .....: Overhung loads on output shaft [N]

$F_a$ .....: Axial loads on output shaft [N]

$i$ .....: Transmission ratio

$J_{ext}$ .....: Total outside moment of inertia reduced to the motor shaft [kgm<sup>2</sup>]

$M_2$ .....: Output torque [N]

$M_a$ .....: Nominal torque [Nm]

$n_1$ .....: Input speed of gearbox [rpm]

$n_2$ .....: Output speed of gearbox [rpm]

$P_e$ .....: Equivalent power [kW]

$P_N$ .....: Nominal power (given on performance tables) [kW]

$P_M$ .....: Power consumption of the driven machine (for alternating power, refer to equivalent power) [kW]

$t$ .....: Time [s]

$T_e$ .....: Equivalent torque [Nm]

#### Erklärung der Bezeichnungen

$c_t$ .....: Koeffizient der Betätigung von Schalter

$f_s$ .....: Betriebsfaktor

$F_{ama}$ .....: Zulässige Axialkräfte auf Abtriebswelle [kN]

$F_{ame}$ .....: Zulässige Axialkräfte auf Antriebswelle [kN]

$F_{qam}$ .....: Zulässige Querkräfte auf Abtriebswelle [N]

$F_{qem}$ .....: Zulässige Querkräfte auf Antriebswelle [N]

$F_{qa}$ .....: Querkräfte auf Abtriebswelle [N]

$F_{qe}$ .....: Querkräfte auf Antriebswelle [N]

$F_q$ .....: Querkräfte auf Abtriebswelle [N]

$F_a$ .....: Axialkräfte auf Abtriebswelle [N]

$i$ .....: Übersetzungsverhältnis

$J_{ext}$ .....: Die Gesamtträgheit der rotierende Teile von der Ausgangsseite reduziert auf Motorwelle [kgm<sup>2</sup>]

$M_2$ .....: Ausgangsdrehmoment [N]

$M_a$ .....: Nenndrehmoment [Nm]

$n_1$ .....: Antriebsdrehzahl [U/min]

$n_2$ .....: Abtriebsdrehzahl [U/min]

$P_e$ .....: Äquivalente Leistung [kW]

$P_N$ .....: Getriebe Nennleistung (siehe Leistung- Drehzahl tabellen) [kW]

$P_M$ .....: Benötigte Leistung an der Abtriebswelle (Zur Berechnung bei variablen Leistungen äquivalente Leistung benutzen) [kW]

$t$ .....: Zeit [s]

$T_e$ .....: Minimales Drehmoment [Nm]

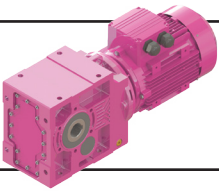

# Genel Bilgiler

## General Information

### Einführung



#### Ürün Yelpazesi

Elinizdeki katalog sadece **K serisi** ürünleri içermektedir.

##### - M ve N Serisi

Helisel alın dişliye sahip, giriş ve çıkış milleri aynı düzlem üzerinde ve birbirine paralel uzanan, üzerlerinde bulunan ayak veya flanş ile makina-ya sabitlenen redüktörlerdir. Dolu mil çıkışlıdır.

##### - D Serisi

Helisel alın dişliye sahip, giriş ve çıkış milleri aynı düzlem üzerinde, birbirine paralel ve belirli bir aralıkta yerleştirilmiş, iki yan yüzde bulunan bağlantı civataları, flanş veya tork kolu ile makina-ya sabitlenen redüktörlerdir. Delik milli veya mil çıkışlı olabilir.

##### - E Serisi

Sonsuz vida ve çark dişlili, belirli bir aralıkta ve birbirine dik konumlandırılmış giriş ve çıkış millerine sahip, çepçevre konumlandırılmış ayak bağlantıları, flanş veya tork kolu ile makina-ya sabitlenebilen redüktörlerdir. Delik milli veya mil çıkışlı olabilir.

##### - Y Serisi

Yatık tip redüktörler, ağır şartlarda çalışmak üzere dizayn edilmiş redüktör tipleridir. Bu tiplerde redüktör ile bunu tahrik eden mekanizma arasında değişik bağlantı şekilleri mevcuttur (Mekanik ve hidrolik kaplinler, çeşitli tip kayışlar ve zincirle tahrik gibi). Delik milli veya mil çıkışlı olabilir.

##### - K Serisi

Helisel alın dişli ve konik dişlilerden oluşan, birbirine dik ve belirli bir aralıkta konumlandırılmış giriş ve çıkış miline sahip, çepçevre sunulan ayaklar, flanş veya tork kolu ile makina-ya sabitlenen redüktörlerdir. E serisinden farklı olarak yüksek verime sahiptirler. Delik milli veya mil çıkışlı olabilir.

##### - H ve B Serisi

Helisel ve/veya konik dişliye sahip ağır hizmet tipi redüktörlerdir. Giriş ve çıkış milleri birbirine paralel veya dik olabilir. Her yönden bağlantı için ayak bağlantıları bulunur. Opsiyonel olarak flanş ile de bağlanabilir. Delik milli veya mil çıkışlı olabilir.

##### - T Serisi

T Serisi redüktörler helisel dişli iki kademe motorsuz delik milli redüktörlerdir. T Serisi redüktörler delik milli olması ve kompakt gövde yapısı sayesinde daha küçük hacimli alanlara montajı yapılabilmektedir.

##### - P ve R Serisi

P ve R Serisi redüktörler planet dişli redüktörlerdir. Endüstriyel ve mobil uygulamalarda kullanılırlar. Diğer redüktör tiplerine göre daha küçük hacimde daha büyük tork iletebilirler.

##### - V Serisi

V vinç redüktörleri M1 - M8 (1Dm - 5m) vinç sınıflarına uygun olarak, çift veya sabit devirli frenli motorlarla üretilebilmektedir.

#### Production Range

*This catalogue is containing K series of gearboxes only.*

##### - M and N Series

*M and N series are helical geared gear units. The input and output shafts are parallel to each other and on the same plane. The gearbox can be connected to the machine by using the foot or flange on the gearbox. Has solid output shaft.*

##### - D Series

*D series are helical geared gearboxes with parallel input and output shafts. The shafts have a distance in between and located on the same plane. The gearbox can be assembled to the machine by using, the connection screws on the sides, flange or torque arm on the gearbox. Can have hollow or solid output shaft.*

##### - E Series

*E series gearboxes are with worm and worm-wheel. The input and output shafts are perpendicular to each other and have a distance in between. It can be assembled to the driven machine by the use of the foot, flange or torque arm on the gearbox. Can have hollow or solid output shaft.*

##### - Y Series

*Horizontal type gearboxes are designed to operate in heavy conditions. In these types there are a lot of combination forms between gearbox and driver (for example, mechanic and hydraulic couplings, various belt and chain drives etc.). Can have hollow or solid output shaft.*

##### - K Series

*These are gearboxes with helical and bevel gears. The input and output shafts are perpendicular to each other and have a distance in between. It can be assembled to the driven machine using the foot, flange or torque arm on the gearbox. They have high efficiency compared to E series. Can have hollow or solid output shaft.*

##### - H and B Series

*These gearboxes are helical or/and bevel geared industrial gearboxes. The input and output shafts can be arranged parallel or perpendicular to each other. The gearbox can be assembled by the use of the foot connections on each side. Flange connections are optional. They can have hollow or solid output shaft.*

##### - T Series

*T Series are gear units which are helical geared, two staged, hollow shaft mounted gear units and manufactured according to monoblock principal. T Series gearboxes have hollow shaft and compact housing so that T series can be mounted on smaller places.*

##### - P and R Series

*P and R Series gearboxes are planetary gearboxes. They are mostly used by industrial and mobile applications. Planetary gearboxes can transfer high torques in small volumes compared to other gearboxes.*

##### - V Series

*V hoist drives are produced according to M1 - M8 (1Dm - 5m) crane classes.*

#### Produktpalette

Dieses Katalog umfasst nur die **K Serie** Getriebe.

##### - M und N Serie

Diese Modelle sind Stirnradgetriebe mit parallelen Antriebs- und Abtriebswelle auf einer Ebene. Die Getriebe werden mit Fuß- oder Flanschverbindung an die angetriebene Maschine angekoppelt. Hat Vollwelle am Ausgang.

##### - D Serie

Diese Getriebe sind Stirnradgetriebe mit paralleler Antriebs- und Abtriebswelle, die auf einer Ebene liegen und einen Abstand zueinander haben. Diese Getriebe wird seitlich mit Gewindelöchern am Maschine oder mit einer Flansch verbindet. Kann Voll- und Hohlwelle am Ausgang haben.

##### - E Serie

Diese Getriebe bestehen aus Schnecke und Schneckenrad. Die Antriebs- und Abtriebswellen sind senkrecht zueinander und haben einen bestimmten Abstand. Das Getriebe wird mit Fußbefestigung, Flanschverbindung oder mit Drehmomentstütze an die angetriebene Maschine montiert. Kann Voll- und Hohlwelle am Ausgang haben.

##### - Y Serie

Diese Getriebe sind für Einsatz unter schweren Bedingungen ausgelegt. Bei dieser Ausführung gibt es sehr viele verschiedene Verbindungsmöglichkeiten zwischen Antrieb und Getriebe (Zum Beispiel; mechanische und hydraulische Kupplungen, Riementrieb, Kettentrieb usw.). Kann Voll- und Hohlwelle am Ausgang haben.

##### - K Serie

Diese Getriebe bestehen aus Stirnräder und Kegelhäder. Die Antrieb und Abtriebswellen sind senkrecht und haben einen Abstand zueinander. Das Getriebe wird mit Fußbefestigung, Flanschverbindung oder Drehmomentstütze an die angetriebene Maschine montiert. Der Wirkungsgrad ist wesentlich höher als E Serie. Kann Voll- und Hohlwelle am Ausgang haben.

##### - H und B Serie

Diese Getriebe sind geeignet für industrielle Anwendungen und haben parallelen oder senkrechten Antrieb und Abtriebswelle auf einer Ebene. Das Getriebe kann mit Füßen, die auf jede Seite der Getriebe vorhanden sind, oder optional mit Flansch an die angetriebene Maschine montiert werden. Kann Voll- und Hohlwelle am Ausgang haben.

##### - T Serie

T Serien Getriebe sind zwei stufige, schrägverzahnte Hohlwellenflachgetriebe in Monoblockgehäuse. Die T Serie hat eine kompakte Gehäuse und ist serienmäßig mit Abgangshohlwelle hergestellt, so dass das Getriebe minimalen Platzbedarf hat.

##### - P und R Serie

P und R Serie sind Planetengetriebe, die vielseitig im Industrie und bei mobiler Anwendungen einsetzbar sind, mit Planetenzahnräder. Planetengetriebe können im Vergleich zu anderen Getrieben größere Drehmomente bei kleineren Bauvolumen übertragen.

##### - V Serie

V Krane und Hebezeuge werden geeignet zur Kranklasse M1 - M8 (1Dm - 5m) hergestellt.

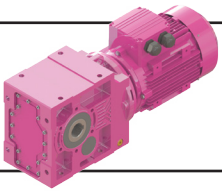

## Genel Bilgiler General Information Einführung

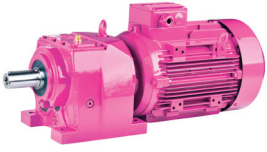

M ...

13 farklı büyüklükte;  
Moment aralığı: 50 - 18.000 Nm  
Devir aralığı: 0,1 - 500 d/dak  
13 different sizes:  
Torque range: 50 - 18.000 Nm  
Speed range: 0,1 - 500 rpm  
13 verschiedene Baugrößen:  
Drehmomentbereich: 50 - 18.000 Nm  
Drehzahlbereich : 0,1 - 500 U/min



N ...

13 farklı büyüklükte;  
Moment aralığı: 50 - 18.000 Nm  
Devir aralığı: 0,1 - 500 d/dak  
13 different sizes:  
Torque range: 50 - 18.000 Nm  
Speed range: 0,1 - 500 rpm  
13 verschiedene Baugrößen:  
Drehmomentbereich: 50 - 18.000 Nm  
Drehzahlbereich : 0,1 - 500 U/min

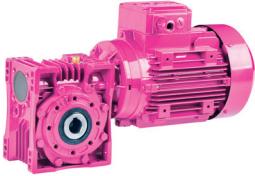

E ...

8 farklı büyüklükte;  
Moment aralığı: 5 - 1.000 Nm  
Devir aralığı: 0,1 - 400 d/dak  
8 different sizes:  
Torque range: 5 - 1.000 Nm  
Speed range: 0,1 - 400 rpm  
8 verschiedene Baugrößen:  
Drehmomentbereich: 5-1.000 Nm  
Drehzahlbereich : 0,1-400 U/min

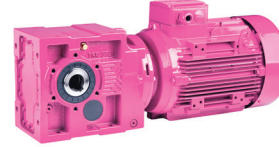

K ...

7 farklı büyüklükte;  
Moment aralığı: 200 - 15.000 Nm  
Devir aralığı: 0,1 - 400 d/dak  
7 different sizes:  
Torque range: 200 - 15.000 Nm  
Speed range: 0,1 - 400 rpm  
7 verschiedene Baugrößen:  
Drehmomentbereich: 200 - 15.000 Nm  
Drehzahlbereich : 0,1 - 400 U/min

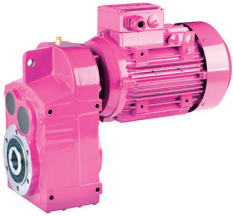

D...

10 farklı büyüklükte;  
Moment aralığı: 130 - 18.000 Nm  
Devir aralığı: 0,1 - 350 d/dak  
10 different sizes:  
Torque range: 130 - 18.000 Nm  
Speed range: 0,1 - 350 rpm  
10 verschiedene Baugrößen:  
Drehmomentbereich: 130 - 18.000 Nm  
Drehzahlbereich : 0,1 - 350 U/min



Y ...

25 farklı büyüklükte;  
Moment aralığı: 1200 - 43000 Nm  
Devir aralığı: 2,6 - 990 d/dak  
25 different sizes:  
Torque range: 1200 - 43000 Nm  
Speed range: 2,6 - 990 rpm  
25 verschiedene Baugrößen:  
Drehmomentber. :1200-43000 Nm  
Drehzahlbereich : 2,6-990 U/min



H ...

14 farklı büyüklükte;  
Moment aralığı: 2.500 - 165.000 Nm  
Devir aralığı: 0,1 - 250 d/dak  
14 different sizes:  
Torque range: 2.500 - 165.000 Nm  
Speed range: 0,1 - 250 rpm  
14 verschiedene Baugrößen:  
Drehmomentber. :2.500 - 165.000 Nm  
Drehzahlbereich : 0,1 - 250 U/min

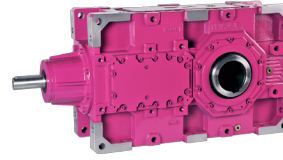

B ...

14 farklı büyüklükte;  
Moment aralığı: 5.000 - 165.000 Nm  
Devir aralığı: 0,1 - 115 d/dak  
14 different sizes:  
Torque range: 5.000 - 165.000 Nm  
Speed range: 0,1 - 115 rpm  
14 verschiedene Baugrößen:  
Drehmomentber. :5.000-165.000 Nm  
Drehzahlbereich : 0,1-115 U/min



P ...

10 farklı büyüklükte;  
Moment aralığı: 1.000 - 50.000 Nm  
Tahvil oranları: 3,5 - 3000 arası  
10 different sizes:  
Torque range: 1.000 - 50.000 Nm  
Transmission ratio: 3,5 - 3000  
10 verschiedene Baugrößen:  
Drehmomentber. : 1.000 - 50.000 Nm  
Übersetzung: 3,5 - 3000

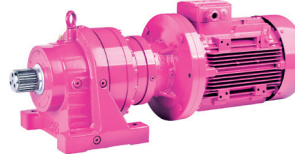

R ...

10 farklı büyüklükte;  
Moment aralığı: 1.000 - 50.000 Nm  
Tahvil oranları: 3,5 - 3000 arası  
10 different sizes:  
Torque range: 1.000 - 50.000 Nm  
Transmission ratio: 3,5 - 3000  
10 verschiedene Baugrößen:  
Drehmomentber. : 1.000 - 50.000 Nm  
Übersetzung: 3,5 - 3000



T ...

10 farklı büyüklükte;  
Moment aralığı: 200 - 18.000 Nm  
Devir aralığı: 46 - 280 d/dak  
10 different sizes:  
Torque range: 200-18.000 Nm  
Speed range: 46-280 rpm  
10 verschiedene Baugrößen:  
Drehmomentber. :200-18.000 Nm  
Drehzahlbereich : 46-280 U/min

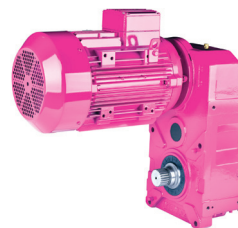

VR ...

VR vinç redüktörleri  
M1 - M8 ,(1Dm - 5m) yük sınıfı  
ISO 4301 / 1 ,(FEM 1.001 / III)  
VR Hoist Drive Units  
M1 - M8 ,(1Dm - 5m) load classification  
ISO 4301 / 1 ,(FEM 1.001 / III)  
VR Kran und Hebezeug Getriebe  
M1 - M8 ,(1Dm - 5m) Belastungsart  
ISO 4301 / 1 ,(FEM 1.001 / III)

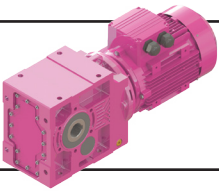

# Genel Bilgiler

## General Information

### Einführung



#### K Serisi Redüktörlerin Genel Özellikleri

K Serisi redüktörler, helisel konik dişli monoblok gövde yapısındaki redüktörlerdir. Giriş ve çıkış milleri 90° olması gereken durumlarda yüksek verim ve mukavemetin gerektirdiği yerler için dizayn edilmiştir.

K Serisi redüktörler E serisinin çok yönlü bağlantı opsiyonları ile M serisinin monoblok ve yüksek verim özellikleriyle birlikte yüksek momente sahip olarak üretilmektedir. Redüktörlerin giriş motor bağlantılarında IEC B5 veya B14, standart akuple veya motorsuz mil girişli gibi esnek montaj opsiyonları kullanılmaktadır.

K serisi redüktörler monoblok gövde içerisinde; küçük gövdeler 2 ve 3 kademe, büyük gövdeler 3 kademe olarak üretilmektedir. Yüksek redüksiyon gerektiren yerlerde 6 kademeye kadar akuple edilerek temin edilebilir.

YILMAZ REDÜKTÖR olarak tasarım prensibimiz;

- Yüksek teknoloji kullanmak
- Güvenilirlik,
- Yüksek güç yoğunluğu,
- Yüksek verim,
- Montaj uyumluluğu,
- Esnek çözümler

#### Dikkat Edilecek Hususlar !

- Bu katalogta verilen resimler görsel amaçlıdır ve şekilsel detaylar bağlayıcı değildir.

- YILMAZ REDÜKTÖR, ürünler ve kataloglar üzerinde, müşterileri bilgilendirmeksizin her türlü değişikliği yapma hakkına sahiptir.

- Ürünler teslim alındıktan sonra ürünle birlikte verilen kullanım kılavuzu okunmadan sistem devreye alınmamalıdır.

- Katalogta verilen yağ miktarları referans amaçlıdır. Gerçek yağ seviyesi için redüktör üzerinde bulunan yağ seviye tapası kullanılmalıdır. Yağ viskozitesi için, redüktör etiketine bakınız.

- Sipariş anında montaj pozisyonu bildirilmeyen redüktörler **M1** montajına uygun sevk edilir. Etiketle yazan montaj pozisyonundan farklı bağlanan redüktörler garanti kapsamından çıkar. Bu katalogta verilen redüktör ağırlıkları ortalama ağırlık değerleridir. Tahvil oranına ve üzerinde bağlı olan aksesuara göre ağırlıklar farklılık gösterebilir.

#### General Specifications of K Series Gearboxes

*K Series gearboxes are helical-bevel geared monoblock housing gearboxes. K Series are designed for higher efficiency and higher strenght required operations. Input and output shafts are perpendicular to each other.*

*K Series gearboxes have advantages of E Series mounting options, monoblock housing and higher efficiency advantages of M series with higher torque capabilities. K Series have flexible connection possibilities which is IEC B5 or B14 connection, directly mounted or solid input shaft options .*

*Small sizes of K series gearboxes can be 2 and 3 stages. Bigger sizes are manufactured only 3 stages in monoblock housing. K series supplied for high reduction operations up to 6 stages by using double housings.*

*As we are YILMAZ REDÜKTÖR,our design principals are;*

- Using high technology*
- Reliability*
- High power density*
- High efficiency*
- Mounting compatible*
- Flexible solutions*

#### Attention to the following points !

*- Drawings are examples only and the details on the drawings or illustrations are not strictly binding.*

*- YILMAZ REDÜKTÖR reserve the right to make all kinds of changes in products and catalogues without any notice.*

*- Prior to commissioning, the operating instructions provided with the gearbox must be observed.*

*- Oil quantities given are guide values only. The exact quantity of oil should be checked by using the provided oil level plugs according mounting positions. For correct oil viscosity refer to the nameplate.*

*- If the mounting position is not informed upon ordering, the gear unit is delivered according **M1** mounting position. A different operation then the indicated mounting position on the name plate cancels the warranty. The weights given in this catalogue are mean values. Depending on the ratio and accessories the weights can differ.*

#### Allgemeine Eigenschaften von K Serie Getrieben

K Serie Getriebe sind Kegelradgetriebe mit Monoblok-Gehäuse. Eingang- und Ausgangswelle sind senkrecht zueinander. Diese Getriebe sind für Einsatzgebiete geeignet bei denen ein hoher Wirkungsgrad und eine hohe Festigkeit benötigt werden.

K Serie Getriebe haben umfangreiche Montagemöglichkeiten, wie E Serie, hohe Momenttragbarkeit mit hohem Wirkungsgrad und Monoblok-Gehäuse, wie M Serie, als Vorteil. Standart Motorverbindung (IEC B14 oder B5) oder Wellenantrieb ist möglich.

Kleine K-Serie Getriebe können mit zwei oder drei Stufen in einem Monoblock-Gehäuse hergestellt werden, wobei große K Serie Getriebe nur mit drei Stufen ebenfalls in einem Monoblock-Gehäuse hergestellt werden. K serien Getriebe können für hohe Untersetzungen mit Hilfe eines zusätzlich gekoppelten Gehäuses bis zu sechs Stufen produziert werden.

Als YILMAZ REDÜKTÖR unsere Entwurfsprinzipien sind;

- Verwenden von hohen Fertigungstechnik
- Hohe Betriebssicherheit
- Leistungsdichte
- Hoher Wirkungsgrad
- Universale Montagemöglichkeit
- Sonderlösungen

#### Bitte folgende Punkte beachten !

- Die Abbildungen sind beispielhaft und nicht verbindlich.

- Alle-Änderungen auf dem Katalog und an der Produkte bleiben vorbehalten und können ohne Kenntnisnahme erfolgen.

- Vor Inbetriebnahme ist die mit gelieferter Betriebsanleitung zu beachten.

-Angaben über Ölmengen sind unverbindlich. Maßgebend ist die Ölstandsschraube in der geeigneten Montageposition. Ölviskosität und Sorte muss den Angaben des Typenschildes entsprechen.

- Wenn die Bauform bei Bestellung nicht angegeben ist, erfolgt die Lieferung in der Bauform **M1**. Wenn die Getriebe anders als auf dem Typenschild benannte Bauform eingesetzt werden, verliert die Garantie ihre Gültigkeit. Die angegebenen Gewichte sind unverbindliche Mittelwerte ohne Zubehör; genauere Gewichte sind abhängig von Zubehör und Übersetzung.

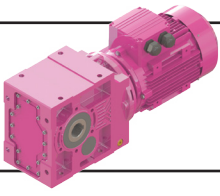

# Genel Bilgiler

## General Information

### Einführung



#### Teknik Tanımlamalar

##### - Çıkış Momenti ( $M_2$ ): [Nm]

Motorun verdiği momentin tahvil oranı ve verimle ile çarpılarak elde edilen değerdir. Redüktörün çıkışından alınabilecek moment gösterir.

##### - Anma Momenti ( $M_a$ ): [Nm]

Redüktörün  $f_s=1$  şartı için mekanik olarak taşıdığı moment değeridir.

##### - Nominal Güç ( $P_n$ ): [kW]

Nominal güç, redüktörün  $f_s=1$  şartı için mekanik olarak taşıyabileceği güç değeridir. Redüktörlerin nominal güçleri, güç devir tablolarında verilmiştir.

##### - Çevrim oranı (i):

Redüktörün giriş devrinin çıkış devrine oranıdır. Yılmaz Redüktör M serisi redüktörlerde 3,5-23500 arasında değişen çevrim oranları mevcuttur.

##### - Eşdeğer Güç ve Moment

$P_{eq}$  [kW],  $T_e$  [Nm]

Sabit devir altında ancak değişken yük değerlerinde çalışan redüktörlerde, sabit yük altında çalışma şartlarına eşdeğer gelen moment ve güç değerleridir. Hesaplama yöntemi sayfa 23'de verilmiştir.

##### - İhtiyaç güç ( $P_M$ ): [kW]

Redüktörlerin kullanılacağı uygulamanın istenilen şekilde çalışabilmesi için ihtiyaç duyduğu güç değeridir.

##### - İhtiyaç moment (T): [Nm]

Redüktörün kullanılacağı uygulamanın çalışabilmesi için ihtiyaç duyduğu moment değeridir. Seçilen redüktör için her zaman çıkış momentini eşit yada daha düşük olmalıdır.

##### - Müsade Edilen Eksenel ve Radyal Yükler

Fqem, Fqam: [N]

Redüktörün giriş veya çıkış milinde müsade edilen eksenel ve radyal yüklerdir.

##### - Servis Faktörü ( $f_s$ ):

Redüktörün çalıştığı şartlar ile uyumlu olması için gerekli olan emniyet katsayısıdır.  $f_s=1$ , düzgün ve sakin yüklerde, günlük sekiz saat, saatte 100 dur-kalk çalışmayı karşılar. Detaylar için redüktör seçim bölümüne bakınız.

#### Teknik Özellikler:

##### - Ses seviyesi:

Redüktörlerimizin ses seviyesi VDI 2159' da verilen redüktörler için müsade edilen ses seviyelerinin altındadır.

##### - Boya ve Korozyon Koruması:

Redüktörlerin standart rengi DIN1843'e göre RAL 7031 dir. İstek üzerine farklı renklerde boyanabilir. Nemli ve korozif bölgeler için istek üzerine farklı boya uygulanabilir.

#### Technical Explanations

##### - Output Torque ( $M_2$ ): [Nm]

Multiplication of motor output torque with transmission ratio and efficiency gives the result of output torque at the output shaft of the gear unit.

##### - Nominal Torque ( $M_a$ ): [Nm]

Nominal torque is the mechanical torque which the gearbox can resist under  $f_s=1$  conditions.

##### - Nominal Power ( $P_n$ ): [kW]

The nominal power is the power which gearbox can mechanically resist under  $f_s=1$  condition. The nominal powers are given on the performance tables.

##### - Ratio (i):

Ratio between output shaft speed and input shaft speed. Available ratios of Yılmaz Redüktör M series are between 3,5 to 23500.

##### - Equivalent Power and Torque

$P_{eq}$ : [kW],  $T_e$  [Nm]

For gearbox unit with constant speed but variable working conditions: This is the calculated power or torque which is equivalent to the values at working under constant working conditions.

##### - Required Power ( $P_M$ ): [kW]

Required power for the applications which is able to drive the system.

##### - Required Torque (T): [Nm]

Required torque for applications. Required torque always must be equal or smaller than output torque for selected gearbox.

##### - Permissible Axial and Overhung Loads:

Fqem, Fqam [N]

Permissible axial and overhung load at the output or input shaft of gearboxes.

##### - Service Factor ( $f_s$ ):

Service factor is a safety coefficient, which takes into account the different running conditions of the driven machine.  $f_s=1$  is used for uniform loads 8 hours working per day and up to 100 cycle per hour.

#### Technical Specifications:

##### - Noise Level:

The noise level of our gearboxes is below the permitted values defined in VDI guidelines 2159 for gear units.

##### - Coating and Corrosion Protection:

The gearboxes are painted with RAL 7031 according DIN1843. Different colors are available upon request. Paintings for high humidity or chemically aggressive environments are available upon request.

#### Technische Erläuterungen

##### - Ausgangsmoment ( $M_2$ ): [Nm]

Multiplikation von Ausgangsmoment des Motors mit Übersetzung und Division das Ergebnis mit Wirkungsgrad ergibt den Betrag von Ausgangsmoment der Getriebe.

##### - Nennmoment ( $M_a$ ): [Nm]

Mechanisches Belastungsmoment der Getriebe unter der Bedingung  $f_s=1$ .

##### - Nennleistung ( $P_n$ ): [kW]

Die Nennleistung ist die mechanische Grenzfestigkeitsleistung für  $f_s=1$ . Kann von der Leistung-Drehzahltable abgelesen werden.

##### - Übersetzung (i):

Wird aus dem Verhältnis von Ausgang- zu Eingangswinkelgeschwindigkeit bestimmt. Gängige Übersetzungen von Yılmaz M Serie Getriebe liegt zwischen 3,5 bis 23500.

##### - Äquivalente Leistung und Moment

$P_{eq}$ : [kW],  $T_e$  [Nm]

Für mit konstanten Drehzahl aber unter veränderlichen Betriebsbedingungen arbeitende Getriebe berechnete Leistung und Moment äquivalent zu Werten beim Arbeiten unter konstanten Betriebsbedingungen.

##### - Notwendige Leistung ( $P_M$ ): [kW]

Für das Getriebe notwendige Leistung, um Arbeiten von Getriebe bei der für das Getriebe gedachten Anwendung zu gewährleisten.

##### - Notwendige Moment (T): [Nm]

Notwendige Moment für Anwendungen. Für den ausgewählte Getriebe soll das notwendige Moment gleich dem Ausgangsmoment oder kleiner als diesem Moment sein.

##### - Zulässige Axial- oder Querkräfte:

Fqem, Fqam [N]

Bei den Anwendungen während der Betrieb zulässige axiale oder radiale Eingangs- oder Ausgangsbelastungen.

##### - Betriebsfaktor ( $f_s$ ):

Dieser Faktor  $f_s$  ist ein Sicherheitsfaktor, damit die Getriebe unter verschiedenen Bedingungen mit genügender Sicherheit arbeitet.  $f_s=1$  gilt für gleichförmig Belastung, mit 8 Betriebsstunden pro Tag und bis zum 100 Schaltungen pro Stunde.

#### Technische Informationen:

##### - Geräuschpegel:

Geräuschstärken aller Getriebe bleiben unter die zulässigen Werte, die für die Getriebe in der VDI-Richtlinie 2159 festgelegt sind.

##### - Lackierung und Korrosionsschutz:

Die Getriebe werden mit der Farbe RAL 7031 nach DIN1843 lackiert. Auf Wunsch sind Sonderlackierungen möglich. Alle Getriebe können auf Wunsch auch in korrosionsgeschützter Ausführung für aggressive Umgebungen geliefert werden.

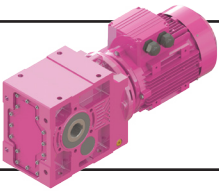

# Genel Bilgiler

## General Information

### Einführung



#### - Yağlama:

K Serisi redüktörler yağlama tablolarında verilen yağlar ile doldurulmaktadır. Yağ detayları için yağlama bölümüne bakınız.

#### - Aksesuarlar:

K Serisi redüktörlerde aşağıdaki aksesuarlar kullanılabilir

- IEC B5 Motor bağlantı flanşları
- Çıkış Bağlantı Flanşları
- Sıkma bileziği
- Geri dönüş kilidi
- Özel keçe çözümleri,
- Şeffaf yağ seviye göstergesi
- Tork kolu
- Elektromanyetik frenler

Diğer özel aksesuarlar için lütfen, YILMAZ REDÜKTÖR ile temasa geçiniz.

#### - Yüzey Koruması

Redüktörlerimiz aksi belirtilmedikçe boyalı olarak sevk edilmektedir. DIN EN ISO 12944-2 korozyon standardında belirtilen sınıflardan aşağıdaki tabloda belirtilen 4 kategori için yüzey koruması sağlanmaktadır. Standart boya sınıfımız C2 korozyon kategorisini karşılamaktadır. Farklı bir koruma sınıfı istenirse sipariş aşamasında belirtilmelidir.

Mil, flanş bağlantı yüzeyi gibi boyanmayan yüzeylere paslanmaya karşı koruma sağlamak için korozyon önleyici yağ sürülmektedir.

#### - Lubrication:

*K series of gearboxes filled with oils which are indicated on lubrication tables. For lubrication details please refer to the lubrication section.*

#### - Accessories:

*The following accessories can be applied to K series gearboxes.*

- IEC B5 Motor connection flange
- Output flanges
- Shrink Discs
- Backstops
- Special sealing solutions,
- Transparent oil level indicator,
- Torque arm,
- Electromagnetic brakes.

*For other accessories please contact, YILMAZ REDÜKTÖR.*

#### - Surface Protection

*Our products are all painted unless otherwise stated. 4 corrosion categories which are mentioned below can be offered according to corrosion categories of DIN EN ISO 12944-2 standard. Our standard paint meets C2 corrosion category. If different category is requested, please inform before order.*

*Unpainted parts such as shaft, flange connection surface are coated with anti-corrosion paint before shipment against corrosion.*

#### - Schmierung:

K Serie Getriebe werden mit Ölen entsprechend der Schmierungstabellen, falls nicht anders vereinbart, geliefert. Für weitere Schmierungsangaben siehe Kapitel Schmierung.

#### - Zubehör:

Folgendes Zubehör kann für Getriebe der K Serie geliefert werden.

- IEC B5 Motor Adapter,
- Abtriebsflansch,
- Schrumpfscheiben,
- Rücklaufsperrn,
- Unterschiedliche Dichtungssysteme,
- Ölstandzeiger,
- Drehmomentstütze,
- Elektromagnetische Bremsen

Für weiteres Zubehör kontaktieren Sie bitte mit, YILMAZ REDÜKTÖR.

#### - Oberflächenschutz

Getriebe von Yılmaz Redüktör werden lackiert und so geliefert falls nicht anders vereinbart ist. Die 4 untenstehenden Korrosionskategorien können nach Korrosionsschutz-Basisnorm DIN EN ISO 12944-2 angeboten werden. Unsere Standard-Lackierung erfüllt C2-Korrosionskategorie. Wenn Sie eine andere Kategorie erwünschen, informieren Sie uns bitte darüber vor der Bestellung.

Nicht lackierte Teile (z.B. Welle, Oberfläche des Anschlussflanschs) werden mit einem Schutzmittel vor dem Versand geschmiert, um vor Korrosion und Rost zu schützen.

Korozyon Kategorisi Corrosion Categories Korrosivitätskategorie	Çevre Şartları Ambient Conditions Umgebungsbedingungen	Boya Tipi Paint Type Lackierung	Boya Kalınlıkları Paint Thickness Sollschichtdicke
C2 (Standard)	<b>İç ortam ve muhafazalı dış ortam</b> <b>Nem ve kirlilik oranı düşük çalışma ortamı</b> <i>Indoor installation and outdoor installation with protection roof</i> <i>Environments with low humidity and contamination</i> Innenaufstellung und Außenaufstellung mit Überdachung oder Schutzeinrichtung Atmosphäre mit niedriger Luftfeuchtigkeit und Verunreinigung	<b>Su Bazlı Astar</b> <i>Water Based Primer Coat</i> Wasserbasierte Grundierung <b>Su Bazlı veya Akrilik Sonkat</b> <i>Water Based or Acrylic Top Coat</i> Wasserbasierte oder Akril-Decklack	80 µm 40 µm
C3	<b>İç ortam ve atmosfere açık dış ortam</b> <b>Orta seviyede nem ve kirlilik olan çalışma ortamı</b> <i>Indoor installation and outdoor installation subject to weathering</i> <i>Environments with mean humidity and contamination</i> Innenaufstellung und Außenaufstellung im Freien unter Bewitterung Atmosphäre mit mäßiger Luftfeuchtigkeit und Verunreinigung	<b>Epoksi Astar</b> <i>Epoxy Primer Coat</i> Epoxy-Grundierung <b>Akrilik Sonkat</b> <i>Acrylic Top Coat</i> Akril-Decklack	80 µm 40 µm
C4	<b>İç ortam ve atmosfere açık dış ortam</b> <b>Genelde yüksek nem ve kimyasal madde olan çalışma ortamı</b> <i>Indoor installation and outdoor installation subject to weathering</i> <i>Environments with occasionally high humidity and chemical contamination</i> Innenaufstellung und Außenaufstellung im Freien unter Bewitterung Atmosphäre gelegentlich mit hoher Luftfeuchtigkeit und chemischer Verunreinigung	<b>Epoksi Astar</b> <i>Epoxy Primer Coat</i> Epoxy-Grundierung <b>Akrilik Sonkat</b> <i>Acrylic Top Coat</i> Akril-Decklack	180 µm 40 µm
C5-I / C5-M	<b>İç ortam ve atmosfere açık dış ortam</b> <b>Sürekli yüksek nem ve kimyasal madde ile temizlik yapılan çalışma ortamı</b> <i>Indoor installation and outdoor installation subject to weathering</i> <i>Environments with permanent high humidity and chemical cleaning contamination</i> Innenaufstellung und Außenaufstellung im Freien unter Bewitterung Atmosphäre mit ständiger hoher Luftfeuchtigkeit und chemischer Verunreinigung (Nassreinigung mit Säuren/Laugen und auch mit chemischen Reinigungsmitteln).	<b>Çinko Yüklemeli Epoksi Astar</b> <i>Epoxy Zinc Primer Coat</i> Epoxy-Zink-Grundierung <b>Epoksi Astar Miox</b> <i>Epoxy Miox Primer Coat</i> Epoxy-Miox-Grundierung <b>Akrilik Sonkat</b> <i>Acrylic Top Coat</i> Akril-Decklack	70 µm 150 µm 40 µm



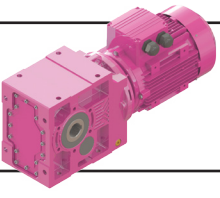

Genel Bilgiler  
General Information  
Einführung



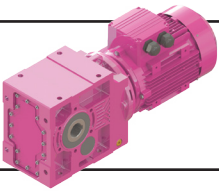

# Genel Bilgiler General Information Einführung



Tip Tanımlaması / Unit Designation / Typenbezeichnung

**K R 3 7 3 . 02 R - M2 T1 - 3 E90S / 4C - L05**

**Fren / Brake / Bremse**

L-220V Fanlı / With Fan / Mit Lüfter	00- 5 Nm	10- 100 Nm
P-24V Fanlı / With Fan / Mit Lüfter	01- 10 Nm	20- 200 Nm
S-220 V Fansız / Without Fan / Ohne Lüfter	02- 25 Nm	30- 300 Nm
Z-24 V Fansız / Without Fan / Ohne Lüfter	04- 40 Nm	40- 400 Nm
	05- 50 Nm	50- 500 Nm

**Kutup sayısı / Number of Poles / Anzahl der Polen**

**Motor Büyüklüğü / Motor Size / Motorbaugröße**

**KV Tipleri için / For KV types / Für Typen KV**

**KN tipleri için / For KN Types / Für Typen KN**

**E90 S / 4**

**Kutup Sayısı / Pole Number /**

Anzahl der polen

**Gövde uzunluğu / Frame Length /**

Gehäuselänge

**Motor büyüklüğü / Motor size /**

Motorbaugröße

**Motor tipi / Motor type /**

Motortyp

**Motor verim sınıfı / Motor efficiency class / Motor-Effizienzklasse**

**A06 : 63 B5 A10 : 100 B5 A20 : 200 B5**

**B06 : 63 B14 B10 : 100 B14 A22 : 225 B5**

**A07 : 71 B5 A11 : 112 B5 A25 : 250 B5**

**A08 : 80 B5 A13 : 132 B5 A31 : 315 B5**

**B08 : 80 B14 B13 : 132 B14**

**A09 : 90 B5 A16 : 160 B5**

**B09 : 90 B14 A18 : 180 B5**

**Tork Kolu Pozisyonu / Torque Arm Position / Position von Drehmomentstütze**

Sayfa 471 ve 472'ye bakınız. / Please see page 471 and 472 / Siehe Seite 471 und 472

**Montaj Pozisyonu / Mounting Position / Bauform**

Sayfa 34'e bakınız. / Please see page 34 / Siehe Seite 34

**Çıkış Mil - Flanş Yönü / Output Shaft - Flange Position / Ausgangswelle - Seite von dem Flansch**

**Çıkış Özelliği / Output Specification / Eigenschaft der Ausgang**

**00 : Standart delik milli / Hollow output shaft / Standarte Ausführung mit Hohlwelle**

**01 : Mil Çıkışlı / Solid output shaft / Vollwelle**

**02 : Flanşlı ve mil çıkışlı / Solid output shaft and with Flange / Mit Flansch und Abtriebsvollwelle**

**03 : Flanşlı ve delik milli çıkışlı / Flanged and hollow output shaft / Mit Flansch und Hohlausgangswelle**

**04 : Çift çıkış milli / With double output shaft / Mit doppelter Abtriebswelle**

**05 : Çift flanşlı ve çift çıkış milli / Double flanged and double output shaft / Mit doppeltem Flansch und doppelter Abtriebswelle**

**08 : Çift flanşlı delik milli / Double flanged and hollow output shaft / Mit doppeltem Flansch und Aufsteckwelle**

**0S : Sıkma Bilezikli / Shrink disk output / Schrumpfscheibe**

**0E : Ekstruder Çıkışlı / Extruder output / Extruder-Ausgang**

**Kademe Sayısı / Stage / Anzahl der Stufen**

**2 kademe / 2 Stages / 2 Stufig**

**3 kademe / 3 Stages / 3 Stufig**

**4 kademe / 4 Stages / 4 Stufig**

**5 kademe / 5 Stages / 5 Stufig**

**6 kademe / 6 Stages / 6 Stufig**

**Revizyon Numarası / Revision Number / Änderungsnummer**

**Gövde Büyüklük / Housing Size / Größe von Gehäuse**

0...8

**Giriş Tipi / Input Type / Eingangstyp**

**R : Motorlu / With Motor / Mit Motor**

**N : Motorsuz ve IEC B5/B14 Flanş girişli / IEC B5 / B14 Flanged without Motor / Ohne Motor und mit IEC B5/B14 Eingangsflansch**

**V : Motorlu ve IEC B5/B14 Flanş girişli / IEC B5 / B14 Flanged with Motor / Mit Motor und IEC B5/B14 Eingangsflansch**

**T : Motorsuz / Without Motor / Eingang mit Vollwelle ohne Motor**

**Redüktör Tipi / Gearbox Type / Getriebe**

**K Serisi / K Serie / K Serie**

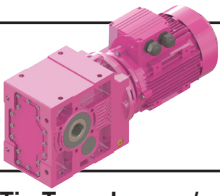

# Genel Bilgiler

## General Information

### Einführung



#### Tip Tanımlaması / Unit Designation / Typenbezeichnung

KR..00..	<b>Konik-Helisel tip redüktörler, motor bağlantılı, delik milli çıkış / Bevel-Helical type geared motors , Direct coupled motor, Hollow shaft output /</b> Kegelradgetriebe, Verbunden mit Motor, Ausgang mit Hohlwelle.
KR..01..	<b>Konik-Helisel tip redüktörler, motor bağlantılı, milli çıkış / Bevel-Helical type geared motors, Direct motor coupled, solid output shaft /</b> Kegelradgetriebe, Verbunden mit Motor, Ausgang mit Vollwelle.
KR..02..	<b>Konik-Helisel tip redüktörler, motor bağlantılı, mil ve flanş çıkışlı / Bevel-Helical type geared motors, Direct motor coupled, Solid output shaft and output flange /</b> Kegelradgetriebe, Verbunden mit Motor, Ausgang mit Vollwelle und Flansch.
KR..03..	<b>Konik-Helisel tip redüktörler, motor bağlantılı delik milli ve flanş çıkışlı / Bevel-Helical type geared motors, Direct motor coupled, Hollow output shaft and output flange /</b> Kegelradgetriebe, Verbunden mit Motor, Ausgang mit Hohlwelle und Flansch.
KR..04..	<b>Konik-Helisel tip redüktörler, motor bağlantılı, çift çıkış milli / Bevel-Helical type gerboxes, Direct motor coupled, double output shaft, /</b> Kegelradgetriebe, Verbunden mit Motor, mit doppelter Ausgangswelle
KR..05..	<b>Konik-Helisel tip redüktörler, motor bağlantılı çift milli ve çift flanş çıkışlı / Bevel-Helical type geared motors, Direct motor coupled, double hollow output shaft and double flange output. /</b> Kegelradgetriebe, Verbunden mit Motor, Ausgang mit Hohlwelle und Flansch.
KR..08..	<b>Konik-Helisel tip redüktörler, motor bağlantılı delik milli ve çift flanş çıkışlı / Bevel-Helical type geared motors, Direct motor coupled, double hollow output shaft and double flange output. /</b> Kegelradgetriebe, Verbunden mit Motor, Ausgang mit Hohlwelle und Flansch.
KR..0S..	<b>Konik-Helisel tip redüktörler, motor bağlantılı, sıkma bilezik çıkışlı / Bevel-Helical type geared motors Direct motor coupled , Shrink disk output /</b> Kegelradgetriebe, Verbunden mit Motor, Ausgang mit Schrumpfscheibe
KR..0E..	<b>Konik-Helisel tip motorlu redüktörler, motor bağlantılı, ekstruder çıkışlı / Bevel-Helical type geared motors Direct motor coupled , extruder output /</b> Kegelradgetriebe, Verbunden mit Motor, Ausgang mit Extruder
KN..00..	<b>Konik-Helisel tip redüktörler, IEC B5/B14 flanşlı motorsuz , delik milli çıkış / Bevel-Helical type gearboxes, IEC B5/B14 flanged input without motor, hollow output shaft /</b> Kegelradgetriebe, ohne Motor mit IEC B5/B14 Flansch , Ausgang mit Hohlwelle.
KN..01..	<b>Konik-Helisel tip redüktörler, IEC B5/B14 flanşlı motorsuz , mil çıkışlı / Bevel-Helical type gearboxes, IEC B5/B14 flanged input without motor, Solid output shaft /</b> Kegelradgetriebe, ohne Motor mit IEC B5/B14 Flansch, Ausgang mit Vollwelle.
KN..02..	<b>Konik-Helisel tip redüktörler, IEC B5/B14 flanşlı motorsuz, mil ve flanş çıkışlı / Bevel-Helical type gearboxes, IEC B5/B14 flanged input without motor, Solid output shaft and output flange /</b> Kegelradgetriebe, ohne Motor mit IEC B5/B14 Flansch, Ausgang mit Vollwelle und Flansch.
KN..03..	<b>Konik-Helisel redüktörler, IEC B5/B14 flanşlı motorsuz, delik milli ve flanş çıkışlı / Bevel-Helical type gearboxes, IEC B5/B14 flanged input without motor, Hollow output shaft and output flange /</b> Kegelradgetriebe, ohne Motor mit IEC B5/B14, Ausgang mit Hohlwelle und Flansch.
KN..04..	<b>Konik-Helisel tip redüktörler, IEC B5/B14 flanşlı motorsuz, çift çıkış milli / Bevel-Helical type gerboxes, IEC B5/B14 flanged without motor, double output shaft, /</b> Kegelradgetriebe, ohne Motor mit IEC B5/B14, mit doppelter Ausgangswelle
KN..05..	<b>Konik-Helisel tip redüktörler, IEC B5/B14 flanşlı motorsuz ,çift milli ve çift flanş çıkışlı / Bevel-Helical type geared motors, IEC B5/B14 flanged input without motor, double hollow output shaft and flange output. /</b> Kegelradgetriebemotor, Verbunden mit Motor, Ausgang mit Hohlwelle und Flansch.
KN..08..	<b>Konik-Helisel tip redüktörler, IEC B5/B14 flanşlı motorsuz ,delik milli ve çift flanş çıkışlı / Bevel-Helical type geared motors, IEC B5/B14 flanged input without motor ,double hollow output shaft and double flange output. /</b> Kegelradgetriebemotor, Verbunden mit Motor, Ausgang mit Hohlwelle und Flansch.
KN..0S..	<b>Konik-helisel tip helisel redüktörler, IEC B5/B14 flanşlı motorsuz, sıkma bilezik çıkışlı / Bevel-Helical type geared motors IEC B5/B14 flanged without motor, Shrink disk Output /</b> Kegelradgetriebemotor, ohne Motor mit IEC B5/B14, Ausgang mit Schrumpfscheibe
KN..0E..	<b>Konik-helisel tip helisel redüktörler, IEC B5/B14 flanşlı motorsuz, ekstruder çıkışlı / Bevel-Helical type geared motors IEC B5/B14 flanged without motor, extruder output /</b> Kegelradgetriebemotor, ohne Motor mit IEC B5/B14, Ausgang mit Extruder.
KV..00..	<b>Konik-Helisel tip helisel redüktörler, IEC B5/B14 flanşlı, motorlu, delik milli çıkış / Bevel-helical type gearboxes, IEC B5/B14 flanged input with coupled motor, hollow output shaft /</b> Kegelradgetriebe, Verbunden mit IEC B5/B14 Motorverbindung, Ausgang mit Hohlwelle.
KV..01..	<b>Konik-Helisel tip helisel redüktörler, IEC B5/B14 flanşlı, motorlu, mil çıkışlı / Bevel-helical type gearboxes, IEC B5/B14 flanged input with coupled motor, solid output shaft /</b> Kegelradgetriebe, Verbunden mit IEC B5/B14 Motorverbindung, Ausgang mit Vollwelle.
KV..02..	<b>Konik-Helisel tip helisel redüktörler, IEC B5/B14 flanşlı, motorlu, mil ve flanş çıkışlı / Bevel-helical type gearboxes, IEC B5/B14 flanged input with coupled motor, with solid output shaft and output flange /</b> Kegelradgetriebe, Verbunden mit IEC B5/B14 Motorverbindung, Ausgang mit Vollwelle und Flansch.
KV..03..	<b>Konik-Helisel tip helisel redüktörler, IEC B5/B14 flanşlı, motorlu, delik milli ve flanş çıkışlı / Bevel-helical type gearboxes, IEC B5/B14 flanged input with coupled motor, Hollow output shaft and output flange /</b> Kegelradgetriebe, Verbunden mit IEC B5/B14 Motorverbindung, Ausgang mit Hohlwelle und Flansch.
KV..04..	<b>Konik-Helisel tip redüktörler, motor bağlantılı, çift çıkış milli / Bevel-Helical type gerboxes, IEC B5/B14 flanged input with coupled motor, double output shaft, /</b> Kegelradgetriebe, Verbunden mit IEC B5/B14 Motorverbindung, mit doppelter Ausgangswelle
KV..05..	<b>Konik-Helisel tip helisel redüktörler, IEC B5/B14 flanşlı, motorlu, çift milli ve çift flanş çıkışlı / Bevel-helical type gearboxes, IEC B5/B14 flanged input with coupled motor, double output shaft and double output flange /</b> Kegelradgetriebe, Verbunden mit IEC B5/B14 Motorverbindung, Ausgang mit Hohlwelle und Flansch.
KV..08..	<b>Konik-Helisel tip redüktörler, IEC B5/B14 flanşlı, motorlu, delik milli ve çift flanş çıkışlı / Bevel-Helical type geared motors, IEC B5/B14 flanged input with direct coupled motor, double hollow output shaft and double flange output. /</b> Kegelradgetriebemotor, Verbunden mit Motor, Ausgang mit Hohlwelle und Flansch.
KV..0S..	<b>Konik-Helisel tip redüktörler, IEC B5/B14 flanşlı motorlu, sıkma bilezik çıkışlı / Bevel-Helical geared motors IEC B5/B14 flanged with direct coupled motor, Shrink disk output /</b> Kegelradgetriebemotor, Verbunden mit IEC B5/B14 Motorverbindung, Ausgang mit Schrumpfscheibe
KV..0E..	<b>Konik-Helisel tip helisel redüktörler, IEC B5/B14 flanşlı motorlu, ekstruder çıkışlı / Bevel-Helical geared motors IEC B5/B14 flanged with direct coupled motor, Extruder Output /</b> Kegelradgetriebemotor, Verbunden mit IEC B5/B14 Motorverbindung, Ausgang mit ekstruder.
KT..00..	<b>Konik-Helisel tip helisel redüktörler, motorsuz ve mil girişli, delik milli çıkış / Bevel-Helical geared unit, Solid shaft input without motor, Hollow output shaft /</b> Kegelradgetriebe, Eingang mit Vollwelle ohne Motor, Ausgang mit Hohlwelle.
KT..01..	<b>Konik-Helisel tip helisel redüktörler, motorsuz ve mil girişli, mil çıkışlı / Bevel-Helical geared units, Solid shaft input without motor, Solid output shaft /</b> Kegelradgetriebe, Eingang mit Vollwelle ohne Motor, Ausgang mit Vollwelle.
KT..02..	<b>Konik-Helisel tip helisel redüktörler, motorsuz ve mil girişli, mil ve flanş çıkışlı / Bevel-Helical gear units, Solid shaft input without motor, Solid output shaft and flange output /</b> Kegelradgetriebe, Eingang mit Vollwelle ohne Motor, Ausgang mit Vollwelle und Flansch.
KT..03..	<b>Konik-Helisel tip helisel redüktörler, motorsuz ve mil girişli, delik milli ve flanş çıkışlı / Bevel-Helical gear units, solid shaft input without motor, Hollow output shaft and output flange /</b> Kegelradgetriebe, Eingang mit Vollwelle ohne Motor, Ausgang mit Hohlwelle und Flansch.
KT..04..	<b>Konik-Helisel tip redüktörler, motor bağlantılı, çift çıkış milli / Bevel-Helical type gerboxes, solid input shaft, double output shaft, /</b> Kegelradgetriebe, Eingang mit Vollwelle, mit doppelter Ausgangswelle
KT..05..	<b>Konik-Helisel tip helisel redüktörler, IEC B5/B14 flanşlı, motorsuz, çift milli ve çift flanş çıkışlı / Bevel-helical type gearboxes, IEC B5/B14 flanged input without motor, double output shaft and double output flange /</b> Kegelradgetriebe, Verbunden mit IEC B5/B14 Motorverbindung, Ausgang mit Hohlwelle und Flansch.
KT..08..	<b>Konik-Helisel tip redüktörler, IEC B5/B14 flanşlı, motorlu, delik milli ve çift flanş çıkışlı / Bevel-Helical type geared motors, IEC B5/B14 flanged input with without motor, double hollow output shaft and double flange output. /</b> Kegelradgetriebemotor, Verbunden mit Motor, Ausgang mit Hohlwelle und Flansch.
KT..0S..	<b>Konik-Helisel tip helisel redüktörler, motorsuz, sıkma bilezik çıkışlı / Bevel-Helical gear motors, Solid shaft input without motor, Shrink Disk Output /</b> Kegelradgetriebe, ohne Motor, Ausgang mit Schrumpfscheibe
KT..0E..	<b>Konik-Helisel tip helisel redüktörler, motorsuz, ekstruder çıkışlı / Bevel-Helical gear motors, Solid shaft input without motor, Extruder Output /</b> Kegelradgetriebe, ohne Motor, Ausgang mit Extruder.

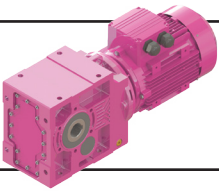

# Genel Bilgiler

## General Information

### Einführung

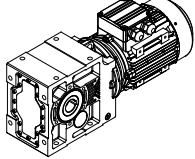
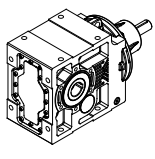
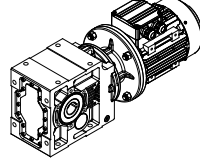
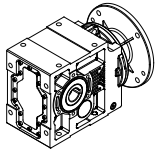
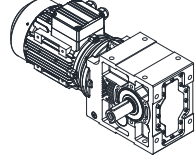
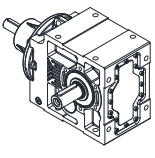
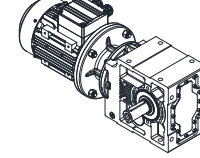
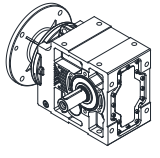
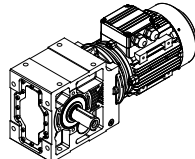
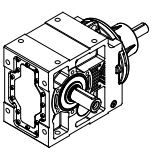
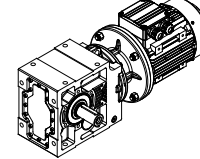
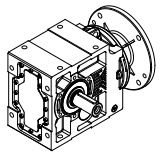
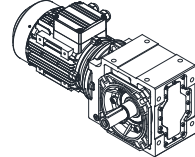
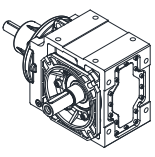
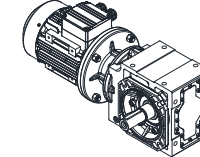
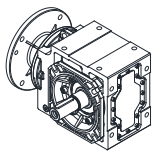
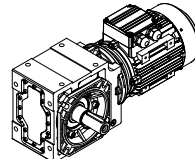
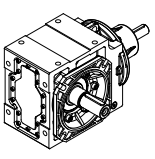
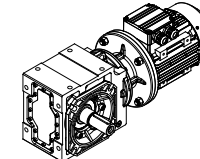
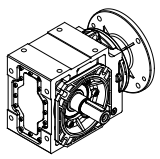
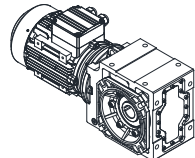
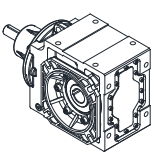
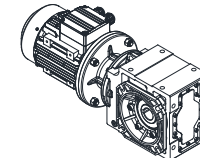
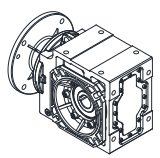
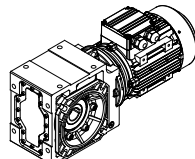
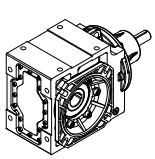
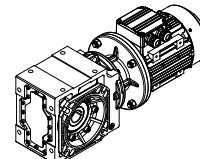
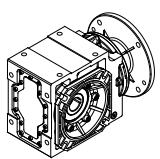
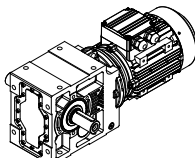
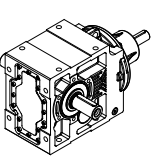
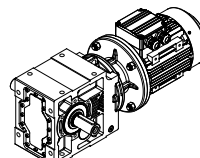
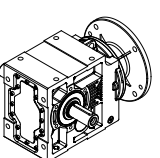
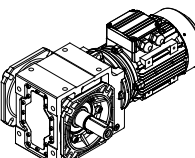
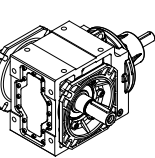
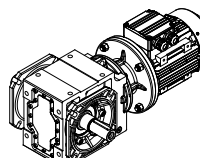
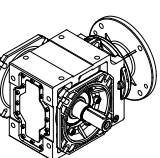
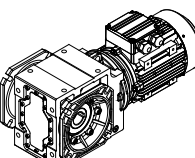
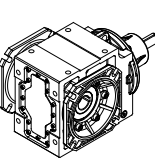
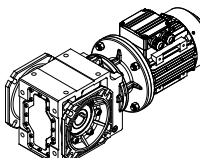
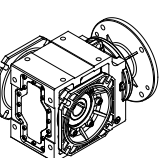

#### Tip Tanımlaması / Unit Designation / Typenbezeichnungen

KR..00 	KT..00 	KV..00 	KN..00 
KR..01R 	KT..01R 	KV..01R 	KN..01R 
KR..01L 	KT..01L 	KV..01L 	KN..01L 
KR..02R 	KT..02R 	KV..02R 	KN..02R 
KR..02L 	KT..02L 	KV..02L 	KN..02L 
KR..03R 	KT..03R 	KV..03R 	KN..03R 
KR..03L 	KT..03L 	KV..03L 	KN..03L 
KR..04 	KT..04 	KV..04 	KN..04 
KR..05 	KT..05 	KV..05 	KN..05 
KR..08 	KT..08 	KV..08 	KN..08 

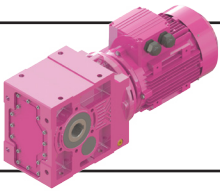

# Genel Bilgiler

## General Information

### Einführung



<b>KR..0SR</b> 	<b>KT..0SR</b> 	<b>KV..0SR</b> 	<b>KN..0SR</b> 
<b>KR..0SL</b> 	<b>KT..0SL</b> 	<b>KV..0SL</b> 	<b>KN..0SL</b> 
<b>KR..0ER</b> 	<b>KT..0ER</b> 	<b>KV..0ER</b> 	<b>KN..0ER</b> 
<b>KR..0EL</b> 	<b>KT..0EL</b> 	<b>KV..0EL</b> 	<b>KN..0EL</b> 

### Örnek Tip Tanımlamaları

#### KR273.00-3E90S/4-L05

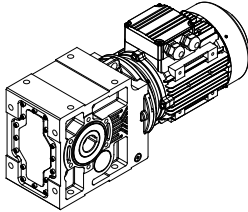

**K**.....: K serisi redüktör  
**R**.....: Motor bağlantılı  
**2**.....: Gövde büyüklük  
**7**.....: Revizyon numarası  
**3**.....: Kademe sayısı  
**00**.....: Delik mil çıkışlı  
**3**.....: Verim Sınıfı IE3  
**E**.....: Motor tipi  
**90S/4**.....: Motor büyüklüğü  
**L05**.....: Fren Tipi

#### KT373.01L

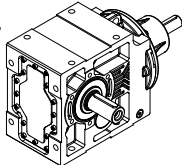

**K**.....: K serisi redüktör  
**T**.....: Motorsuz giriş mili  
**3**.....: Gövde büyüklüğü  
**7**.....: Revizyon numarası  
**3**.....: Kademe sayısı  
**01**.....: Mil çıkışlı  
**L**.....: Sol mil çıkışlı  
**R**.....: Sağ mil çıkışlı

### Sample Designations

#### KR273.00-3E90S/4-L05

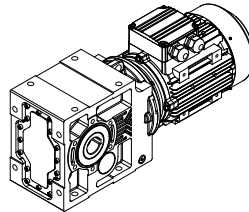

**K**.....: K serie of gearbox  
**R**.....: Direct motor coupled  
**2**.....: Gear unit size  
**7**.....: Revision number  
**3**.....: Stage number  
**00**.....: Hollow shaft output  
**3**.....: Efficiency class IE3  
**E**.....: Motor type  
**90S/4**.....: Motor frame size  
**L05**.....: Brake type

#### KT373.01L

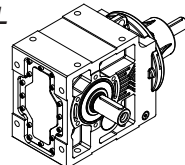

**K**.....: K series of gearbox  
**T**.....: Solid input shaft  
**3**.....: Gear unit size  
**7**.....: Revision number  
**3**.....: Stage number  
**01**.....: Solid output shaft  
**L**.....: Left side output shaft  
**R**.....: Right side output shaft

### Typenbezeichnungsbeispiele

#### KR273.00-3E90S/4-L05

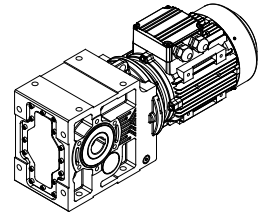

**K**.....: K Serie Getriebe  
**R**.....: Motorverbindung  
**2**.....: Größe von Gehäuse  
**7**.....: Änderungsnummer  
**3**.....: Stufenanzahl (2 stufig)  
**00**.....: Hohlansgangswelle  
**3**.....: Effizienzklasse IE3  
**E**.....: Motortyp  
**90S/4**.....: Motorbaugröße  
**L05**.....: Bremse

#### KT373.01L

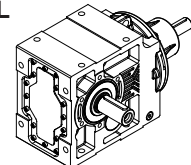

**K**.....: K Serie Getriebe  
**T**.....: Vollwelleneingang ohne Motor  
**3**.....: Größe der Gehäuse  
**7**.....: Änderungsnummer  
**3**.....: Stufenanzahl  
**01**.....: Vollwelle  
**L**.....: Ausgangswelle-links  
**R**.....: Ausgangswelle-rechts

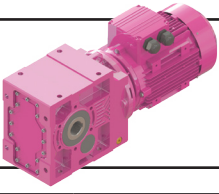

# Genel Bilgiler

## General Information

### Einführung



### Motor Büyüklüğüne Göre Geometrik Mümkün Çevrim Oranları

*Geometrically Possible Combinations of Ratios According to Motor Size*  
Geometrisch mögliche Kombinationen von Übersetzungen nach Motorbaugröße

#### Motor Büyüklüğü / Motor Size / Motorbaugröße

Tip Type	Kademe Stages	63	71	80	90	100	112	132
KR002..	2	7,46-19,88	7,46-19,88	7,46-19,88	7,46-13,26	-	-	-
KR003..	3	23,79-120,91	23,79-120,91	23,79-29,95 45,41-57,16	23,79-29,95 45,41-57,15	-	-	-
KR102..	2	6,28-25,50	6,28-25,50	6,28-25,50	6,28-17,30	-	-	-
KR103..	3	20,03-129,27	20,03-129,27	20,03-76,13 116,34-129,27	20,03-76,13	-	-	-
KR202..	2	6,38-23,79	6,38-23,79	6,38-23,79	6,38-23,79	6,38-15,26	6,38-10,57	-
KR203..	3	26,31-138,53	26,31-138,53	26,31-119,62	26,31-119,62	26,31-104,49	26,31-72,37	-
KR273..	3	6,94-113,65	6,94-113,65	6,94-83,48	6,94-83,48	6,94-72,92	6,94-50,51	-
KR275..	5	54,40-719,79	54,40-719,79	54,40-719,79	54,40-719,79	-	-	-
KR276..	6	735,5-1759,48	735,5-1759,48	735,42-1759,48	735,42-1759,48	-	-	-
KR373..	3	-	7,73-9,97 14,44-21,90 33,65-148,75	7,73-9,97 14,44-21,90 33,65-110,61	7,73-9,97 14,44-21,90 33,65-110,61	5,68-97,26	5,68-68,65	5,68-51,05
KR374..	4	127,14-367,43	127,14-367,43	127,14-367,43	127,14-367,43	-	-	-
KR375..	5	312,5-1094,97	312,5-1094,97	312,5-1094,97	312,5-1094,97	-	-	-
KR376..	6	853,34-3467,39	853,34-3467,39	853,34-3467,39	853,34-3467,39	-	-	-
KR473..	3	-	-	23,76-30,11 60,63-153,47	23,76-30,11 60,63-153,47	7,48-110,95	6,21-97,79	6,21-76,83
KR474..	4	-	160,79-472,63	160,79-472,63	160,79-472,63	160,75-207,41	160,79-181,88	-
KR475..	5	509,34-1767,9	509,34-1767,9	509,34-1767,9	509,34-1767,9	509,34-1142,99	509,34-971,77	-
KR476..	6	2183,54-5226,85	2183,54-5226,85	2183,54-5226,85	2183,54-5226,85	2183,54-3602,83	2183,54-3379,28	-
KR573..	3	-	-	-	-	20,24-25,78 44,73-125,51	20,24-25,78 38,16-109,86	6,91-97,19
KR574..	4	-	117,96-469,74	117,96-469,74	117,96-469,74	117,96-328,56	117,96-158,64 246,42	117,96
KR575..	5	507,09-2236,28	507,09-2236,28	507,09-2236,28	507,09-2236,28	-	-	-
KR576..	6	2328,84-6611,61	2328,84-6611,61	2328,84-6611,61	2328,84-6611,61	-	-	-
KR673..	3	-	-	-	-	80,38-128,24	80,38-128,24	8,31-14,49 18,74-128,24
KR674..	4	-	-	123,38-363,81	123,38-363,81	123,38-363,81	123,38-321,51	123,38
KR675..	5	-	531,08-1875,03	531,08-1875,03	531,08-1875,03	423,90-1875,03	423,90-809,27	423,90-724,08
KR676..	6	-	1884,33-12680,66	1884,33-12680,66	1884,33-12680,66	1884,33-5445,72	1884,33-3844,04	1884,33-2858,39
KR773..	3	-	-	-	-	-	-	11,44-12,89 23,52-26,52 45,36-111,63
KR774..	4	-	-	127,11-396,00	127,11-396,00	127,11-396,00	127,11-396,00	127,11-311,14
KR775..	5	-	547,17-2066,04	547,17-2066,04	547,17-2066,04	436,74-2066,04	436,74-833,78	436,74-655,11
KR776..	6	-	1941,39-15618,73	1941,39-15618,73	1941,39-15618,73	1941,39-5610,63	1941,39-3960,44	1941,39-2944,95
KR873..	3	-	-	-	-	-	-	-
KR874..	4	-	-	-	-	86,63-438,70	86,63-383,99	86,63-339,7
KR875..	5	-	463,83-1891,08	463,83-1891,08	463,83-1891,08	463,83-1891,08	463,83-1671,18	463,83-1313,07
KR876..	6	-	2074,42-12789,19	2074,42-12789,19	2074,42-12789,19	2074,42-11245,67	2074,42-7938,12	2074,42-5902,70

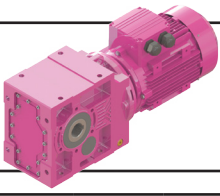

# Genel Bilgiler

## General Information

### Einführung



#### Motor Büyüklüğüne Göre Geometrik Mümkün Çevrim Oranları

Geometrically Possible Combinations of Ratios According to Motor Size  
Geometrisch mögliche Kombinationen von Übersetzungen nach Motorbaugröße

#### Motor Büyüklüğü / Motor Size / Motorbaugröße

Tip Type Typ	Kademe Stages Stufen	160	180	200	225	250	280
KR002..	2	-	-	-	-	-	-
KR003..	3	-	-	-	-	-	-
KR102..	2	-	-	-	-	-	-
KR103..	3	-	-	-	-	-	-
KR202..	2	-	-	-	-	-	-
KR203..	3	-	-	-	-	-	-
KR273..	3	-	-	-	-	-	-
KR275..	5	-	-	-	-	-	-
KR276..	6	-	-	-	-	-	-
KR373..	3	-	-	-	-	-	-
KR374..	4	-	-	-	-	-	-
KR375..	5	-	-	-	-	-	-
KR376..	6	-	-	-	-	-	-
KR473..	3	6,21-23,19 ; 25,15 39,11-59,19 ; 64,17	6,21-20,07 39,11-51,22	-	-	-	-
KR474..	4	-	-	-	-	-	-
KR475..	5	-	-	-	-	-	-
KR476..	6	-	-	-	-	-	-
KR573..	3	6,91-82,14	6,91-67,37	6,91-18,80 30,25-35,34	-	-	-
KR574..	4	-	-	-	-	-	-
KR575..	5	-	-	-	-	-	-
KR576..	6	-	-	-	-	-	-
KR673..	3	8,31-100,90	8,31-90,21	8,31-68,47	8,31-9,45 16,54-21,32 39,26-44,65	-	-
KR674..	4	-	-	-	-	-	-
KR675..	5	423,9-489,82	423,9	-	-	-	-
KR676..	6	-	-	-	-	-	-
KR773..	3	7,41-111,63	7,41-99,00	7,41-76,59	7,41-51,13	7,41-51,13	-
KR774..	4	-	-	-	-	-	-
KR775..	5	-	-	-	-	-	-
KR776..	6	-	-	-	-	-	-
KR873..	3	11,05-13,93 19,26-24,28 34,28-115,87	11,05-13,93 19,26-24,28 34,28-103,24	9,63-81,06	9,63-55,53	9,63-55,53	9,63-43,22
KR874..	4	86,63-235,47	86,63-235,47	-	-	-	-
KR875..	5	-	-	-	-	-	-
KR876..	6	-	-	-	-	-	-

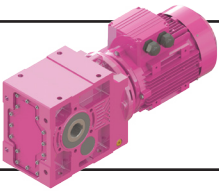

# Genel Bilgiler

## General Information

### Einführung



#### Servis Faktörü

Servis faktörü (fs) redüktörün çalıştığı şartlar ile uyumlu olması için gerekli olan emniyet katsayısıdır. "fs =1" Düzgün ve sakin yüklerde, günlük sekiz saat ve saatte yüz start çalışmayı karşılar.

Aşağıdaki etkenlere bağlıdır:

- Günlük çalışma süresi
- Yük sınıfı
- Bir saatteki start sayısı
- Redüktör tahrik tipi
- Diğer gözlemler

Bu etkenleri göz önüne aldığımızda, gerekli servis faktörünü belirlemek için:

1. Makinanın günlük çalışma süresini tespit ediniz.
2. Makinanın ne türde yükler verdiğini tespit ediniz (Sayfa 17-18).

- U - Düzgün ve sabit yükler
- M - Orta darbeli yükler
- H - Ağır darbeli yükler

Yük sınıfının daha teknik seçimi için rotora indirgenmiş toplam atalet momenti formülünden faydalanabilirsiniz (Sayfa 18).

3. Saatteki start sayısını tespit ediniz.
4. İlk üç maddeye bağlı servis faktörünü aşağıdaki tablodan seçiniz.

5. fs Redüktörümüzün tahrik tipine bağlı olarak "k" katsayısı ile çarpılarak artırılır.

- k=1 :Elektrik motoru veya hidromotor  
k=1.25 :İçten yanmalı çok silindirli motor  
k=1.5 :İçten yanmalı tek silindirli motor

#### Service Factor

Service Factor (fs) is a safety coefficient, which takes into account the different running conditions of the driven machine. "fs=1" is used for uniform loads 8 hours working per day and up to 100 starts per hour.

Service factor depends on:

- Running time
- Nature of load
- Frequency of starting
- Driver type
- Other considerations

For the right selection of the needed service factor for your machine;

1. Determine the running time of driven machine.
2. Select the nature of load of driven machine (Page 17-18).

- U - Uniform loads
- M - Moderate loads
- H - Heavy shock loads

For a better selection, the nature of load can be calculated from the formulas given (page 18).

3. Determine frequency of starting.
4. After determining the above mentioned factors, the service factor can be easily selected from the table given below.
5. The selected service factor multiplied with the factor "k" according to the driver type;

- k=1 :Electric motor or Hydrolicmotor  
k=1.25 :Multicylinder internal combustion engine  
k=1.5 :Single cylinder internal combustion engine

#### Betriebsfaktor

Der Betriebsfaktor (fs) ist ein Sicherheitsfaktor für die Getriebe, damit sie unter den Betriebsbedingungen sicher arbeiten. "fs =1" steht für gleichförmige Belastung, 8 Stunden pro Tag und bis zu 100 Schaltungen pro Stunde.

Betriebsfaktor ist abhängig von:

- Betriebsdauer
- Belastungsart
- Schalthäufigkeit
- Antriebsart
- Andere Faktoren

Um die richtigen Betriebsfaktor festzulegen;

1. Betriebsdauer der angetriebenen Maschine bestimmen.
2. Belastungsart der angetriebenen Maschine auswählen.

- U - Gleichförmige Belastung
- M - Ungleichförmige Belastung
- H - Stark Ungleichförmige Belastung

Um eine bessere Auswahl zu treffen, können die Belastungsarten mit den angegebenen Formeln (Seite 18) errechnet werden.

3. Schalthäufigkeit bestimmen.
4. Nach Bestimmen der oben angegebenen Werte, können die Betriebsfaktoren von der unten stehenden Tabelle entnommen werden.
5. Der ausgewählte Betriebsfaktor muß mit dem Faktor "k" abhängig von der Antriebsart multipliziert werden

- k=1 :Elektromotor oder Hydraulikmotor  
k=1.25 :Vielzylindermotor  
k=1.5 :Einzyldermotor

Günlük Çalışma Süresi  
Operating Time hour / Day  
Laufzeit Std. / Tag

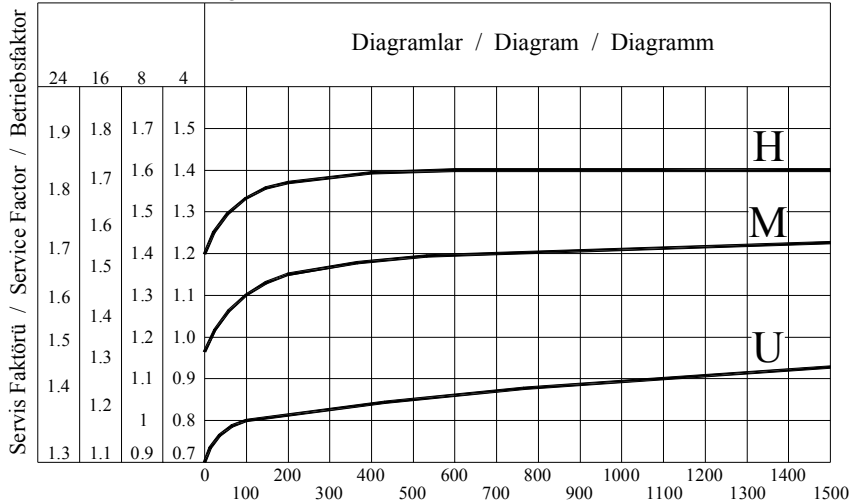

Start sayısı / Saat  
Cycle / Hour  
Schaltungen / Std.



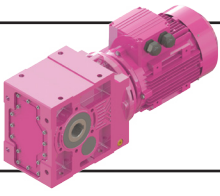

# Genel Bilgiler

## General Information

### Einführung



#### Yük Sınıflandırması

##### Krenler:

- U - Kaldırma Dişlileri
- Palanga Dişlileri
- M - Bomlu Vinç Dişlileri
- Yana Döndürme Dişlileri
- H - Yürütme Dişlileri

##### Pompalar:

- U - Santrifuj Pompalar (ince sıvı)
- M - Santrifuj Pompalar (yarı sıvı)
- H - Basınçlı Pompalar
- Dalgiç Pompalar

##### Taş ve Kil İşleme Makinaları:

- H - Çekiçli Değirmenler
- Döner Fırınlr
- Dövücü Değirmenler
- Kırıcılar
- Küreli Değirmenler
- Tuğla Presi
- Tüp Değirmenler

##### Tekstil Makinaları:

- M - Basma ve Boyama Makinaları
- Dokuma Tezgahları
- Hallac Makinaları
- Harman Makinaları
- Taneleme (Debegat )Tekneleri

##### Yağ Sanayi:

- M - Besleme Pompaları
- Döner Delme Teçhizatları

##### Yiyecek Sanayi:

- M - Kutu Bıçaklar
- Kutu Kaplama
- Mayalama Tekneleri
- H - Kenar Açma

##### Çamaşır Yıkama Makinaları:

- M - Döner Kurutucular
- Yıkama Makinaları

##### Hadde Makinaları:

- M - Hız Ayarlı Silindirler
- Sabit Silindirler
- Sarma Makaraları
- Tel Çekme
- H - Çubuk Kesme Makinaları
- Döner Tablalar (büyük)
- Kabuk Sıyırma Makinaları
- Plaka Haddeleme
- Silindir Haddeleme
- Soğuk Haddeleme

#### Load Classification

##### Cranes:

- U - Hoist Gears
- Lifting Gears
- M - Defrocking jib Gears
- Slowing Gears
- H - Travelling Gears

##### Pumps:

- U - Centrifugal Pumps (light liquids)
- M - Centrifugal Pumps (semi liquid)
- H - Pressure Pumps
- Plunger Pumps

##### Stone and Clay Working Machines:

- H - Hammer Mills
- Rotary Kilns
- Beater Mills
- Breakers
- Ball Mills
- Brick Presses
- Tup Mills

##### Textile Machines:

- M - Printing and Dyeing Machines
- Looms
- Willow
- Batchers
- Tanning Vats

##### Oil Industry:

- M - Pipeline Pumps
- Rotary Drilling Equipment

##### Food Industry:

- M - Cane Knives
- Cane Crushers
- Mach Tubs
- H - Cane Mills

##### Laundries:

- M - Tumblers
- Washing Machines

##### Metal Rolling Mills:

- M - Roller Adjustment Drives
- Roller Straightened
- Winding Machines
- Wire Drawing Benches
- H - Billet Shears
- Rotary Tables (heavy)
- Descaling Machines,
- Sheet Mills
- Manipulators
- Cold Rolling Mills

#### Belastungsart

##### Krananlagen:

- U - Einziehwerke
- Hubwerke
- M - Schwenkwerke
- Wippwerke
- H - Fahrwerke

##### Pumpen:

- U - Kreiselpumpen (leichte Flüssigkeit)
- M - Kreiselpumpen (zahe Flüssigkeit)
- H - Prebpumpen
- Plungerpumpen

##### Stein- und Erdebearbeitende Maschine

- H - Hammermühlen
- Drehofen
- Schlagmühlen
- Brecher
- Kugelmühlen
- Ziegelpressen
- Rohrmühlen

##### Textilmaschinen:

- M - Drukerei
- Farbereimachinen
- Aufwickler
- Webstuhle
- Gerbfasser
- Reibwolfe

##### Erdölgewinnung:

- M - Pipeline Pumpen
- Rotative Bohranlagen

##### Nahrungsmittelmachinen:

- M - Rohrschneiden
- Knetmaschinen
- Maichen
- H - Rohrmühlen

##### Waschereimaschinen:

- M - Trommeltrockner
- Waschmaschinen

##### Wälzwerke:

- M - Rollenrichtmaschinen
- Walzenantriebe
- Drahtzuge
- Haspeln
- H - Blechscheren
- Rollgänge (schwer)
- Knüppelscheren
- Schöpfscheren
- Stranggubanlagen
- Kaltwälzwerke

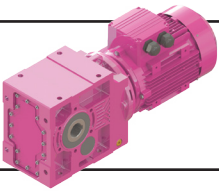

# Genel Bilgiler

## General Information

### Einführung



#### İnşaat Makinaları:

- M - Beton Mikserleri  
- Ağır Yük Asansörleri

#### Kağıt Makinaları:

- H - Islak Presler  
- Kağıt Hamur Makinaları  
- Kurutma Silindirleri  
- Perdahlama Silindirleri

#### Kauçuk Makinaları:

- M - Kalenderler  
- Mikserler  
H - Extruderler  
- Hamur Karma  
- Silindirler

#### Kimya Sanayi:

- M - Agitatörler (yarı sıvı)  
- Kurutma Merdaneleri  
- Mikserler ve Silindirleri

#### Konveyörler:

- M - Bant Cepeli Konveyörler  
- Çelik Bantlı Konveyörler  
- Dökme Yüklü Kayışlı Konv.  
H - Yük Asansörleri  
- Parça Yüklü Kayışlı Konv.

#### Building Machines:

- M - Concrete Mixers  
- Hoist

#### Paper Machines:

- H - Wet Presses  
- Pulpers  
- Drying Cylinders  
- Glazing Cylinders

#### Rubber Machinery:

- M - Calenders  
- Mixers  
H - Extruders  
- Pug Mills  
- Rolling Mills

#### Chemical Ind.:

- M - Aggidators (semi- liquid)  
- Drying Drums.  
- Mixers and Rolling Mills

#### Conveyors:

- M - Band Pocket Conveyors  
- Steel Belt Conveyors  
- Belt Conveyors  
H - Hoists  
- Bulk Belt Conveyors

#### Baumaschinen:

- M - Betonmischermaschinen  
- Bauaufzüge

#### Papiermaschinen:

- H - Naßpressen  
- Gautschen  
- Trockenzyylinder  
- Glattzyylinder

#### Kunststoffmaschinen:

- M - Kalender  
- Mischer  
H - Extruder  
- Knetwerke  
- Wälzwerke

#### Chemische Industrie:

- M - Rührwerke (leichte Flüssig.)  
- Trockentrommeln  
- Mischer und Wälzwerke

#### Förderanlagen:

- M - Gurtaschenbecherwerke  
- Stahlbandförderer  
- Gurtbandförderer (Schüttgut)  
H - Schrägaufzüge  
- Gurtbandförderer (Stückgut)

U	<b>Uniform Yük</b> Uniform Loads Gleichförmige Last	$F_i < 0,25$
M	<b>Orta Darbeli Yük</b> Moderate Loads Ungleichförmige Last	$F_i < 3$
H	<b>Darbeli Yük</b> Heavy Shock Loads Stark Ungleichförmige Last	$F_i < 10$

$$J'_{ext} = \frac{J_{ext}}{i^2}$$

$$F_i = \frac{J'_{ext}}{J_{rotor}}$$

$J'_{ext}$  : **Motor miline indirgenmiş toplam dış atalet momenti**  
External moments of inertia reduced to the motor shaft  
Externe Massenträgheitsmomente reduziert auf Motorwelle

$i$  : **Tahvil oranı**  
Transmission ratio  
Übersetzung

$J_{rotor}$  : **Motorun atalet momenti**  
Moments of inertia to the motor  
Massenträgheitsmoment

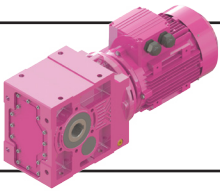

# Genel Bilgiler

## General Information

### Einführung



#### Redüktör Dönüş Yönleri

K Serisi ürünlerimiz için kullanılan yön tanımlaması aşağıdaki gibidir. Aşağıdaki tanımlama kilitli redüktörler için de geçerlidir.

#### Direction of Rotation

K Series direction of rotation of Yılmaz products are defined as follows. The definitions are also valid for gear units with backstop.

#### Getriebedrehrichtungen

Die Drehrichtungen für K Serie Getriebe sind wie folgt definiert. Die Definition ist auch bei Getrieben mit Rücklaufsperrung gültig.

	3-5 Kademe / 3-5 Stages / 3-5 Stufig	2-4-6 Kademe / 2-4-6 Stages / 2-4-6 Stufig
<b>Saat Yönünde</b> Clockwise Rechtslauf  <b>CW</b>		
<b>Saat Tersi Yönünde</b> Counter Clockwise Linkslauf  <b>CCW</b>		

Giriş mili dönüş yönüne göre çıkış mili dönüş yönleri aşağıdaki gibidir.

Output shaft rotation directions according to the input shaft rotation directions are as follows.

Drehrichtungen der Abtriebswelle im Abhängigkeit von der Antriebswellen sind wie folgendes;

3-5 kademe / 3-5 Stages / 3-5 Stufig	2-4-6 Kademe / 2-4-6 Stages / 2-4-6 Stufig

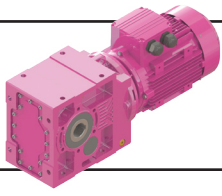

# Genel Bilgiler

## General Information

### Einführung



### Radyal Yükler

Çıkış miline gelebilecek radyal yükler yatak ömrüne göre belirlenmiş ve tablo halinde verilmiştir. Bu tabloda verilen  $F_{qam}$  güvenilir radyal yükü  $f_s=1$  şartı ve yükün mil ortasını yüklediği durum için verilmiştir. Darbeli yüklerin olması durumunda daha önce verilmiş olan servis faktörü tablosundaki değerler dikkate alınmalıdır. Güvenilir aksiyal yük ( $F_{ama}$  veya  $F_{ame}$ ) verilen güvenilir radyal yükün ( $F_{qam}$  veya  $F_{qem}$ ) %25'i kadar alınır. Verilen radyal ve eksenel yükler kuvvetin en kötü açı şartında etki ettiği durum için verilmiştir. Mil ortasına gelen kuvvetin açısına göre daha yüksek radyal yükler mümkündür (Firmamıza danışınız). Bağlantı şekline göre oluşan radyal yük  $F_q$  sayfa 21 de verilen formüller yardımı ile hesaplanır. Redüktör seçiminde ;

$$\begin{aligned} F_{qa} &\leq F_{qam} \\ F_{qe} &\leq F_{qem} \end{aligned}$$

şartı göz önünde tutulmalı. Eğer etkiyen radyal kuvvet milin orta noktasında değil ise verilen güvenilir değer in aşağıda verilen formül ile düzeltilmesi gerekir.

$$\begin{aligned} F_{qam}' &= F_{qam} \frac{t}{y+u} \\ F_{qem}' &= F_{qem} \frac{t}{y+u} \end{aligned}$$

"t", "y" Değerleri aşağıda verilmiştir. "u" Değeri görüldüğü gibi kuvvetin uygulama noktasıdır.

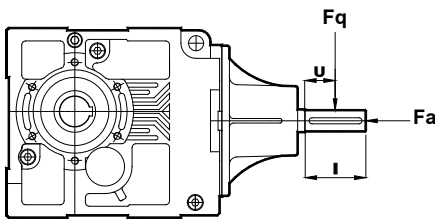
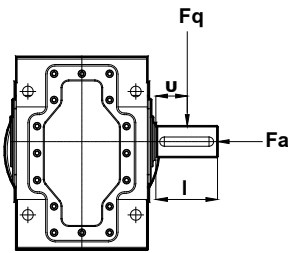

### Overhung Loads

The permissible overhung loads are calculated by considering working life and is listed on the tables. The given permissible overhung loads  $F_{qam}$  are based on  $f_s=1$  and are valid for forces which are applied to the midpoint of the shaft. For shock loading applications the service factor given on the table must take into consideration. The permissible axial load ( $F_{ama}$  or  $F_{ame}$ ) is %25 x ( $F_{qam}$  or  $F_{qem}$ ). The listed permissible overhung loads are based on the worst loading direction. Higher overhung loads can be applied for different loading directions (Please ask if requested). The effective overhung load at the gear box shaft  $F_q$  will be determined with the given formulas on page 21. In Selection ;

$$\begin{aligned} F_{qa} &\leq F_{qam} \\ F_{qe} &\leq F_{qem} \end{aligned}$$

these formulas must be taken into consideration. If the load is not applied at the midpoint of the shaft; the given permissible load must be corrected with the following formulas.

$$\begin{aligned} F_{qam}' &= F_{qam} \frac{t}{y+u} \\ F_{qem}' &= F_{qem} \frac{t}{y+u} \end{aligned}$$

The values "t", "y" can be taken from the below table. The value "u" is the length of the application point as shown below.

### Querkräfte

Die in den nachfolgenden Tabellen angegebenen zulässigen Radialbelastungen  $F_{qam}$  gelten bei Kraftangriff auf die Mitte Wellenendes. Den Angaben liegt der Betriebsfaktor  $f_s=1$  zu Grunde. Bei stoßartigen Belastungsfällen ist auch hier der entsprechende Betriebsfaktor zu berücksichtigen. Zulässige Axialkräfte  $F_{ama}$  oder  $F_{ame}$  können ohne weitere Nachrechnung bis zu einer Höhe von ca. 25% der zulässigen Radialbelastung  $F_{qam}$  oder  $F_{qem}$  aufgenommen werden. Bei der Ermittlung der zulässige Querkräfte sind höhere Werte möglich (Bitte Rückfragen). Die auftretende Querkraft  $F_q$  ab der Getriebewelle wird wie in der nachfolgenden Formel bestimmt.

Bei dieser Auswahl;

$$\begin{aligned} F_{qa} &\leq F_{qam} \\ F_{qe} &\leq F_{qem} \end{aligned}$$

müssen die oben angegebenen Bedingungen berücksichtigt werden. Ist der Kraftangriff nicht auf Wellenmitte, so kann die zulässige Querkraft mit Hilfe der unten stehenden Formel auf jede beliebige Stelle umgerechnet werden.

$$\begin{aligned} F_{qam}' &= F_{qam} \frac{t}{y+u} \\ F_{qem}' &= F_{qem} \frac{t}{y+u} \end{aligned}$$

Die Werte "t" und "y" sind in den nachfolgenden Tabellen angegeben. Der Wert "u" ist die Stelle des Kraftangriffs wie auf der nächsten Seite angegeben.

KR...01 Çıkış mili radyal kuvvet hesabı düzeltme katsayıları Overhung Load correcting values on output shaft Querkraft auf Ausgangswelle Korrigierungszahlen										
Tip Type Typ	KR..002 KR..003	KR..102 KR..103	KR..202 KR..203	KR..273	KR..373	KR..473	KR..573	KR..673	KR..773	KR..873
t	119	134	156	162	199	236	273	344	408	485
y	99	104	121	132	159	186	213	274	323	380
l	40	60	70	60	80	100	120	140	170	210

KT... Giriş mili Radyal kuvvet hesabı düzeltme katsayıları Overhung load correcting values on input shaft Querkraft auf Eingangswelle korrigierungszahlen										
Tip Type Typ	KT..002 KT..003	KT..102 KT..103	KT..202 KT..203	KT..273	KT..373	KT..473	KT..573	KT..673	KT..773	KT..873
t	78	78	111	111	126	137	158	180	207	220
y	58	58	86	86	96	102	113	130	147	165
l	40	40	50	50	60	70	90	100	120	110

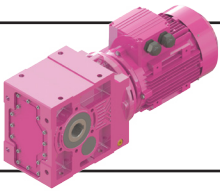

# Genel Bilgiler

## General Information

### Einführung



#### Radyal Yüklerin Hesabı

#### Calc. Of Overhung Loads

#### Berechnung der Querkräfte

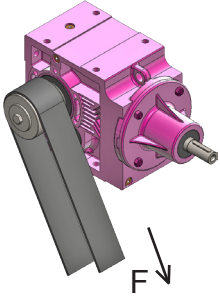

Radyal Yük  $F_q$  [N]'nin hesaplanması da, gerekli tahrik momenti  $M$  [Nm], kasnak veya dişli çapı  $D$  [mm] olmak üzere aşağıdaki formüller kullanılır.

Radial Load  $F_q$  [N] is calculated with the following equations where required moment  $M$  [Nm] and hoop or gear diameter  $D$  [mm] is used.

Der Fall der radialen Belastung  $F_q$  [N] kann mit den angegebenen Gleichungen berechnet werden. Antriebsmoment  $M$  [Nm] und Zahnrad- oder Riemenscheiben Durchmesser  $D$  [mm].

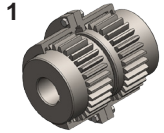

#### 1. Elastik Kaplin

Çalışma sırasında oluşan sapmalar kaplinin güvenlik sınırları içinde ise kuvvetler ihmal edilebilir.

#### 1. Elastic Coupling

If Elastic Coupling is working in its reliable working area, the overhung loads can be neglected.

#### 1. Elastische Kupplung

Wenn die elastische Kupplung in ihrem zulässigen Arbeitsbereich arbeitet, können die radialen Belastungen vernachlässigt werden.

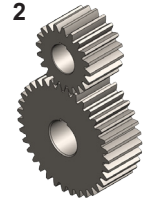

#### 2. Düz Dişli

(20° kavrama açısı)

$$F_q = \frac{2100 \times M_2}{D}$$

#### 2. For Spur Gear

(Pressure angle 20°)

$$F_q = \frac{2100 \times M_2}{D}$$

#### 2. Stirnradgetriebe

(Angriffswinkel 20°)

$$F_q = \frac{2100 \times M_2}{D}$$



#### 3. Küçük Hızlarda Zincir Dişli ( $z > 17$ )

$$F_q = \frac{2100 \times M_2}{D}$$

#### 3. For Chain Drive With Low Speed ( $z > 17$ )

$$F_q = \frac{2100 \times M_2}{D}$$

#### 3. Kettenantrieb mit niedriger Geschwindigkeit ( $z > 17$ )

$$F_q = \frac{2100 \times M_2}{D}$$

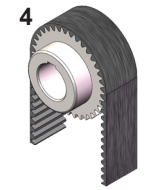

#### 4. Triger Kayış

$$F_q = \frac{2500 \times M_2}{D}$$

#### 4. For Triger Belt

$$F_q = \frac{2500 \times M_2}{D}$$

#### 4. Zahnriemenantrieb

$$F_q = \frac{2500 \times M_2}{D}$$

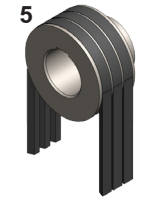

#### 5. V Kayış

$$F_q = \frac{5000 \times M_2}{D}$$

#### 5. For V Belt

$$F_q = \frac{5000 \times M_2}{D}$$

#### 5. Keilriemenantrieb

$$F_q = \frac{5000 \times M_2}{D}$$



#### 6. Gerdirme Makaralı Kayış

$$F_q = \frac{5000 \times M_2}{D}$$

#### 6. Flat Belt With Spanning Pulley

$$F_q = \frac{5000 \times M_2}{D}$$

#### 6. Flachriemenantrieb mit Spannungstrommel

$$F_q = \frac{5000 \times M_2}{D}$$

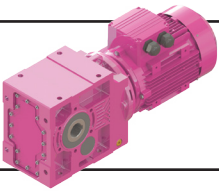

# Genel Bilgiler

## General Information

### Einführung



### Ekstruder Tiplerde Müsade Edilebilir Eksenel Yükler

Permissible Axial Loads for Extruder Types  
Zulässige Axialkräfte für Extruder Typ Getriebe

KRE273					
n <sub>2</sub>	F <sub>ama</sub> [kN]				
	Ömür / Lifetime / Lebensdauer Lh [saat] / [hour] / [Stunde]				
	40000	20000	10000	5000	
20	27.0	33.3	41.0	50.5	
30	23.9	29.5	36.3	44.7	
40	22.0	27.0	33.3	41.0	
50	20.5	25.3	31.1	38.4	
65	19.0	23.4	28.8	35.5	
80	17.8	22.0	27.0	33.3	
100	16.7	20.5	25.3	31.1	
120	15.8	19.4	23.9	29.5	
140	15.1	18.6	22.9	28.2	
160	14.5	17.8	22.0	27.0	
180	14.0	17.2	21.2	26.1	
200	13.5	16.7	20.5	25.3	
220	13.2	16.2	20.0	24.6	
240	12.8	15.8	19.4	23.9	
260	12.5	15.4	19.0	23.4	
280	12.2	15.1	18.6	22.9	
300	12.0	14.8	18.2	22.4	
320	11.8	14.5	17.8	22.0	

n<sub>2</sub> : Çıkış Devri [d/dak]  
Output Speed [rpm]  
Abtriebsdrehzahl [U/min]

KRE373					
n <sub>2</sub>	F <sub>ama</sub> [kN]				
	Ömür / Lifetime / Lebensdauer Lh [saat] / [hour] / [Stunde]				
	40000	20000	10000	5000	
20	104.8	129.0	158.8	195.6	
30	92.7	114.2	140.6	173.2	
40	85.1	104.8	129.0	158.8	
50	79.6	98.0	120.6	148.5	
65	73.5	90.5	111.5	137.3	
80	69.1	85.1	104.8	129.0	
100	64.6	79.6	98.0	120.6	
120	61.2	75.3	92.7	114.2	
140	58.4	71.9	88.5	109.0	
160	56.1	69.1	85.1	104.8	
180	54.2	66.7	82.1	101.1	
200	52.5	64.6	79.6	98.0	
220	51.0	62.8	77.3	95.2	
240	49.7	61.2	75.3	92.7	
260	48.5	59.7	73.5	90.5	
280	47.4	58.4	71.9	88.5	
300	46.5	57.2	70.4	86.7	
320	45.6	56.1	69.1	85.1	

n<sub>2</sub> : Çıkış Devri [d/dak]  
Output Speed [rpm]  
Abtriebsdrehzahl [U/min]

KRE473					
n <sub>2</sub>	F <sub>ama</sub> [kN]				
	Ömür / Lifetime / Lebensdauer Lh [saat] / [hour] / [Stunde]				
	40000	20000	10000	5000	
20	134.5	165.6	203.9	251.1	
30	119.0	146.6	180.5	222.3	
40	109.2	134.5	165.6	203.9	
50	102.1	125.7	154.8	190.7	
65	94.4	116.2	143.1	176.2	
80	88.7	109.2	134.5	165.6	
100	82.9	102.1	125.7	154.8	
120	78.5	96.7	119.0	146.6	
140	75.0	92.3	113.7	140.0	
160	72.0	88.7	109.2	134.5	
180	69.5	85.6	105.4	129.8	
200	67.3	82.9	102.1	125.7	
220	65.4	80.6	99.2	122.2	
240	63.8	78.5	96.7	119.0	
260	62.2	76.6	94.4	116.2	
280	60.9	75.0	92.3	113.7	
300	59.6	73.4	90.4	111.3	
320	58.5	72.0	88.7	109.2	

n<sub>2</sub> : Çıkış Devri [d/dak]  
Output Speed [rpm]  
Abtriebsdrehzahl [U/min]

KRE573					
n <sub>2</sub>	F <sub>ama</sub> [kN]				
	Ömür / Lifetime / Lebensdauer Lh [saat] / [hour] / [Stunde]				
	40000	20000	10000	5000	
20	172.0	211.8	260.8	779.6	
30	152.3	187.5	230.9	715.9	
40	139.7	172.0	211.8	673.9	
50	130.6	160.8	198.1	643.1	
65	120.7	148.7	183.0	608.6	
80	113.4	139.7	172.0	582.6	
100	106.1	130.6	160.8	555.9	
120	100.4	123.7	152.3	535.0	
140	95.9	118.1	145.4	518.0	
160	92.1	113.4	139.7	503.6	
180	88.9	109.5	134.8	491.3	
200	86.1	106.1	130.6	480.6	
220	83.7	103.1	126.9	471.0	
240	81.5	100.4	123.7	462.5	
260	79.6	98.0	120.7	454.8	
280	77.9	95.9	118.1	447.8	
300	76.3	93.9	115.6	441.3	
320	74.8	92.1	113.4	435.4	

n<sub>2</sub> : Çıkış Devri [d/dak]  
Output Speed [rpm]  
Abtriebsdrehzahl [U/min]

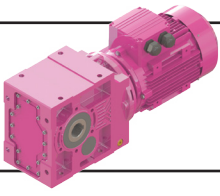

# Genel Bilgiler

## General Information

### Einführung



### Ekstruder Tiplerde Müsade Edilebilir Eksenel Yükler

Permissible Axial Loads for Extruder Types  
Zulässige Axialkräfte für Extruder Typ Getrieben

KRE673				
n <sub>2</sub>	F <sub>ama</sub> [kN]			
	Ömür / Lifetime / Lebensdauer Lh [saat] / [hour] / [Stunde]			
	40000	20000	10000	5000
20	209.5	258.0	317.7	391.2
30	185.5	228.4	281.3	346.4
40	170.1	209.5	258.0	317.7
50	159.1	195.9	241.3	297.1
65	147.1	181.1	223.0	274.6
80	138.2	170.1	209.5	258.0
100	129.2	159.1	195.9	241.3
120	122.3	150.6	185.5	228.4
140	116.8	143.8	177.1	218.1
160	112.2	138.2	170.1	209.5
180	108.3	133.4	164.2	202.2
200	104.9	129.2	159.1	195.9
220	102.0	125.6	154.6	190.4
240	99.3	122.3	150.6	185.5
260	97.0	119.4	147.1	181.1
280	94.8	116.8	143.8	177.1
300	92.9	114.4	140.9	173.5
320	91.1	112.2	138.2	170.1

n<sub>2</sub> : Çıkış Devri [d/dak]  
Output Speed [rpm]  
Abtriebsdrehzahl [U/min]

KR773				
n <sub>2</sub>	F <sub>ama</sub> [kN]			
	Ömür / Lifetime / Lebensdauer Lh [saat] / [hour] / [Stunde]			
	40000	20000	10000	5000
20	350.2	431.3	531.1	653.9
30	310.1	381.8	470.2	579.0
40	284.4	350.2	431.3	531.1
50	266.0	327.5	403.3	496.6
65	245.8	302.7	372.8	459.0
80	231.0	284.4	350.2	431.3
100	216.0	266.0	327.5	403.3
120	204.5	251.8	310.1	381.8
140	195.2	240.4	296.0	364.5
160	187.6	231.0	284.4	350.2
180	181.0	222.9	274.5	338.0
200	175.4	216.0	266.0	327.5
220	170.5	209.9	258.5	318.3
240	166.1	204.5	251.8	310.1
260	162.1	199.6	245.8	302.7
280	158.5	195.2	240.4	296.0
300	155.3	191.2	235.5	290.0
320	152.3	187.6	231.0	284.4

n<sub>2</sub> : Çıkış Devri [d/dak]  
Output Speed [rpm]  
Abtriebsdrehzahl [U/min]

KRE873				
n <sub>2</sub>	F <sub>ama</sub> [kN]			
	Ömür / Lifetime / Lebensdauer Lh [saat] / [hour] / [Stunde]			
	40000	20000	10000	5000
20	403.4	496.7	611.7	753.2
30	357.1	439.8	541.5	666.9
40	327.6	403.4	496.7	611.7
50	306.3	377.2	464.5	572.0
65	283.1	348.7	429.3	528.7
80	266.0	327.6	403.4	496.7
100	248.8	306.3	377.2	464.5
120	235.5	290.0	357.1	439.8
140	224.9	276.9	341.0	419.9
160	216.0	266.0	327.6	403.4
180	208.5	256.8	316.2	389.4
200	202.0	248.8	306.3	377.2
220	196.3	241.8	297.7	366.6
240	191.3	235.5	290.0	357.1
260	186.7	229.9	283.1	348.7
280	182.6	224.9	276.9	341.0
300	178.9	220.3	271.2	334.0
320	175.4	216.0	266.0	327.6

n<sub>2</sub> : Çıkış Devri [d/dak]  
Output Speed [rpm]  
Abtriebsdrehzahl [U/min]

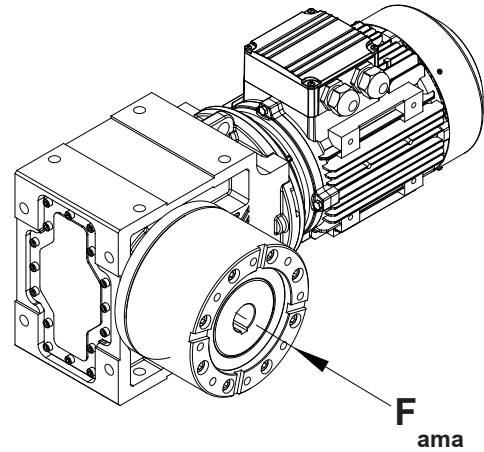

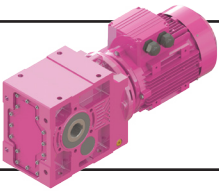

# Genel Bilgiler

## General Information

### Einführung



### Eşdeğer Güç Hesabı

Sabit devirde, ancak değişken momentlerde (güçlerde) çalışan redüktörler için eşdeğer tork altındaki, eşdeğer güç hesaplanabilir. Bu eşdeğer güç kullanılarak bilinen sabit güçteki redüktör seçim yöntemi kullanılarak seçim yapılabilir. Burada ağırlıklı torka göre eşdeğer anma torku belirlenmektedir. Hesaplanan bu güçte çalışan redüktör, teorik olarak, değişken yüklerde çalışan redüktör ile aynı emniyet değerine ve ömre sahiptir.

Bir çevrim boyunca oluşan değişken torklar, en yüksek torktan, en düşüğe doğru yatay zaman eksenini boyunca sıralanır (bakınız alttaki şekil). Bu şekile göre eşdeğer tork şu formül ile hesaplanır;

$$T_e = \left( \frac{\Delta t_1 \times T_1^{6.6} + \dots + \Delta t_n \times T_n^{6.6}}{t} \right)^{\frac{1}{6.6}}$$

Eğer  $T_n$  değerleri (en düşük tork),  $T_e$ 'nin 0,5 katının altında ise, bu tork dilimi yok sayılarak, işlem tekrarlanır;

Eğer  $T_n < T_e \times 0.5$  ise

$$T_e = \left( \frac{\Delta t_1 \times T_1^{6.6} + \dots + \Delta t_{n-1} \times T_{n-1}^{6.6}}{t - \Delta t_n} \right)^{\frac{1}{6.6}}$$

Tüm  $T_n$  değerleri  $T_e$ 'nin 0,5 katının üzerinde ise, eşdeğer güç aşağıdaki gibi hesaplanır;

$$P_{eq} = P_N = \frac{T_e \times n}{9550}$$

Eşdeğer gücün bulunmasından sonra eşdeğer güç değeri kullanılarak, bu katalogta verilen redüktör seçimi bölümünde anlatılan adımlar uygulanarak redüktör seçimi tamamlanır.

### Equivalent Power Rating Calculation

The equivalent power by an equivalent constant torque can be calculated for gearboxes working in constant speed but variable torques (or powers). Using this equivalent power it is possible to make a gearbox selection according to the usual gearbox selection method with constant torques. The equivalent torque will be determined according to the mean of dominating torques. The gearbox working in constant equivalent torque will theoretically have the same lifetime and safety compared to the variable torque one.

To calculate the equivalent torques, the variable torques in a cycle must be sorted from the maximal to the minimal on a horizontal time line (Check the graphic below). According to the graphic below the equivalent torque can be calculated with the following formula;

$$T_e = \left( \frac{\Delta t_1 \times T_1^{6.6} + \dots + \Delta t_n \times T_n^{6.6}}{t} \right)^{\frac{1}{6.6}}$$

If  $T_n$  (the lowest torque) is lower than 50 % of  $T_e$ , this torque part must be taken out of the torque graph and the calculation must be repeated;

If  $T_n < T_e \times 0.5$  then

$$T_e = \left( \frac{\Delta t_1 \times T_1^{6.6} + \dots + \Delta t_{n-1} \times T_{n-1}^{6.6}}{t - \Delta t_n} \right)^{\frac{1}{6.6}}$$

If all  $T_n$  values are higher than 50% of  $T_e$  then the equivalent power can be calculated by the following formula;

$$P_{eq} = P_N = \frac{T_e \times n}{9550}$$

After the equivalent power is determined the selection of gearbox is made according to the selection procedures given on the gearbox selection part in this catalogue.

### Berechnung äquivalenter Leistung

Die äquivalente Leistung bei äquivalenten Drehmoment kann für Getrieben mit konstanten Drehzahl und variablen Momente berechnet werden. Mit dieser Leistung kann das Getriebe ausgelegt werden, wie bei konstanten Leistung. Man bestimmt hiermit also die maßgebende Belastung. Das ausgelegte Getriebe erreicht theoretisch dem gleichen Lebensdauer und hat die gleiche Sicherheit.

Für die Berechnung der äquivalenten Drehmoment müssen die einzelnen Drehmomentanteile auf eine Zeitachse von größten bis zu kleinsten angeordnet werden (siehe unteres Bild). Das äquivalente Drehmoment wird nach folgender Formel berechnet;

$$T_e = \left( \frac{\Delta t_1 \times T_1^{6.6} + \dots + \Delta t_n \times T_n^{6.6}}{t} \right)^{\frac{1}{6.6}}$$

Wenn  $T_n$  (niedrigstes Drehmoment) kleiner als 50% von  $T_e$  ist, muss dieser Anteil vernachlässigt werden und die Berechnung soll neu durchgeführt werden;

Wenn  $T_n < T_e \times 0.5$  dann

$$T_e = \left( \frac{\Delta t_1 \times T_1^{6.6} + \dots + \Delta t_{n-1} \times T_{n-1}^{6.6}}{t - \Delta t_n} \right)^{\frac{1}{6.6}}$$

Wenn alle  $T_n$  Werte höher als 50% von  $T_e$  sind, dann wird die äquivalente Leistung nach folgender Formel berechnet;

$$P_{eq} = P_N = \frac{T_e \times n}{9550}$$

Nach Bestimmung der äquivalenter Leistung, erfolgt die Getriebeauslegung wie bei konstanter Leistung. Die Auswahlverfahren für konstante Leistung ist in diesem Katalog angegeben.

(Moment / Torque / Moment)

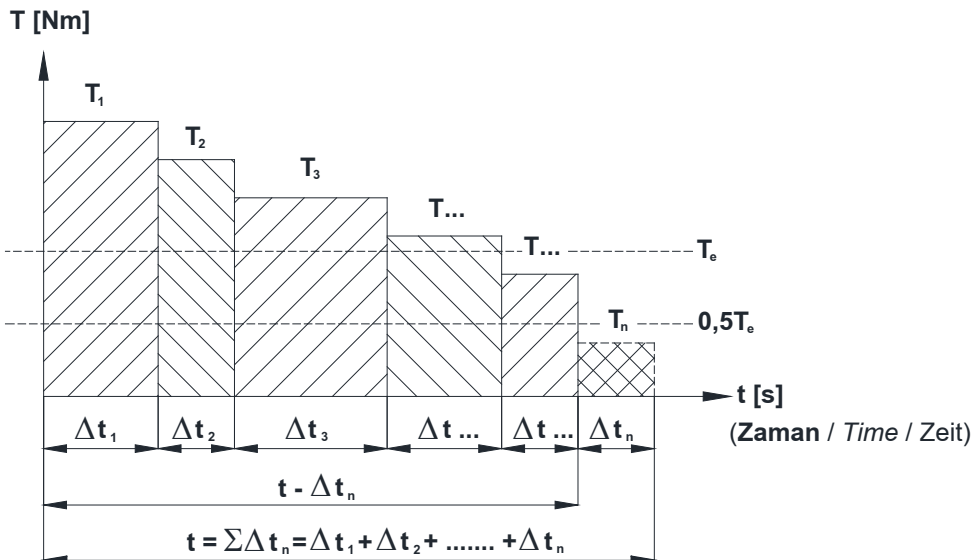



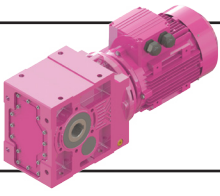

# Genel Bilgiler

## General Information

### Einführung



#### Eşdeğer Güç Hesabı Örneği

Çift yönlü çalışan ham demir haddesi için aşağıdaki çalışma koşulları belirlenmiş;

##### Veriler:

Toplam bir iş çevrimi: 2 dak.

1. Yük kademesi: 48 kNm, 30 sn
2. Yük Kademesi: 32 kNm, 22 sn
3. Yük Kademesi: 28 kNm, 15 sn
4. Yük Kademesi: 16 kNm, 10 sn
5. Yük Kademesi: 5 kNm, 43sn

Makina sabit devri: 50 d/dak

Redüktör seçimine esas olacak eşdeğer yük aranmaktadır.

##### Çözüm:

Bir çevrimin toplam zamanı;

$$t = t_1 + t_2 + t_3 + t_4 + t_5 = 120 \text{ sn}$$

Eşdeğer Tork;

$$T_e = \left( \frac{30 \times 48^{6,6} + \dots + 43 \times 5^{6,6}}{120} \right)^{\frac{1}{6,6}}$$

$$= 39,2 \text{ kNm}$$

%50 eşdeğer tork;

$$0,5 \times T_e = 19,6 \text{ kNm}$$

Her bir tork dilimi bu değer üzerinde olmalı

$$T_{4,5} < 0,5 \times T_e$$

%50 torkun altındakileri çıkararak hesabı tekrarlayalım;

$$t' = t_1 - t_4 - t_5 = 120 - 43 - 10 = 67 \text{ s}$$

$$T_e = \left( \frac{30 \times 48^{6,6} + 22 \times 32^{6,6} + 15 \times 28^{6,6}}{67} \right)^{\frac{1}{6,6}}$$

$$= 42,9 \text{ kNm}$$

Moment ve devir değerlerini kullanarak eşdeğer gücümüzü hesaplayalım;

$$P_{eq} = \frac{T_e \times n}{9550} = \frac{42,9 \times 1000 \times 50}{9550} = 225 \text{ kW}$$

Yukarıdaki güç ve devir değeri kullanılarak bu katalogta anlatılan seçim prosedürü ile redüktör seçimi yapılabilir.

#### Equivalent Power Rating Sample

The following data is given for a reversing blooming mill;

##### Torque steps:

Total one cycle time: 2 min.

- 1st torque part: 48 kNm, 30 s
- 2nd torque part: 32 kNm, 22 s
- 3th torque part: 28 kNm, 15 s
- 4th torque part: 16 kNm, 10 s
- 5th torque part: 5 kNm, 43 s

Machine constant speed: 50 rpm

The equivalent power, which is required for gear unit selection, is to determine.

##### Solution:

Total time in a cycle;

$$t = t_1 + t_2 + t_3 + t_4 + t_5 = 120 \text{ sn}$$

Equivalent Torque;

$$T_e = \left( \frac{30 \times 48^{6,6} + \dots + 43 \times 5^{6,6}}{120} \right)^{\frac{1}{6,6}}$$

$$= 39,2 \text{ kNm}$$

50% of Equivalent torque;

$$0,5 \times T_e = 19,6 \text{ kNm}$$

Every torque part must be lower then this value;

$$T_{4,5} < 0,5 \times T_e$$

We are repeating the calculation by taking out the torque parts, which are below 50%;

$$t' = t_1 - t_4 - t_5 = 120 - 43 - 10 = 67 \text{ s}$$

$$T_e = \left( \frac{30 \times 48^{6,6} + 22 \times 32^{6,6} + 15 \times 28^{6,6}}{67} \right)^{\frac{1}{6,6}}$$

$$= 42,9 \text{ kNm}$$

By using the equivalent torque and constant speed we calculate the equivalent power;

$$P_{eq} = \frac{T_e \times n}{9550} = \frac{42,9 \times 1000 \times 50}{9550} = 225 \text{ kW}$$

Now by using the above calculated equivalent power and constant speed we camake the gear-box selection with the procedures described in this catalogue.

#### Beispiel für äquivalente Leistung

Die nachfolgenden Angaben sind für eine Blechreversierwalze;

##### Drehmoment stufen:

Gesamte Zeit für einem Arbeitszyklus: 2 min.

- Drehmomentanteil 1: 48 kNm 30 s
- Drehmomentanteil 2: 32 kNm 22 s
- Drehmomentanteil 3: 28 kNm 15 s
- Drehmomentanteil 4: 16 kNm 10 s
- Drehmomentanteil 5: 5 kNm 43 s

Maschine hat konstante Drehzahl: 50 U/min

Gesucht ist die äquivalente Leistung, die für die Getriebeauslegung nötig ist.

##### Lösung:

Gesamte Zeit für einem Arbeitszyklus;

$$t = t_1 + t_2 + t_3 + t_4 + t_5 = 120 \text{ sn}$$

Äquivalentes Drehmoment;

$$T_e = \left( \frac{30 \times 48^{6,6} + \dots + 43 \times 5^{6,6}}{120} \right)^{\frac{1}{6,6}}$$

$$= 39,2 \text{ kNm}$$

50% von äquivalenten Drehmoment;

$$0,5 \times T_e = 19,6 \text{ kNm}$$

Drehmomentanteile müssen größer als dieser Wert sein;

$$T_{4,5} < 0,5 \times T_e$$

Wir wiederholen die Berechnung nochmals ohne die kleine Drehmomentanteile;

$$t' = t_1 - t_4 - t_5 = 120 - 43 - 10 = 67 \text{ s}$$

$$T_e = \left( \frac{30 \times 48^{6,6} + 22 \times 32^{6,6} + 15 \times 28^{6,6}}{67} \right)^{\frac{1}{6,6}}$$

$$= 42,9 \text{ kNm}$$

Mit Hilfe von äquivalenten Drehmoment und konstanter Drehzahl berechnet man die äquivalente Leistung;

$$P_{eq} = \frac{T_e \times n}{9550} = \frac{42,9 \times 1000 \times 50}{9550} = 225 \text{ kW}$$

Nach Bestimmung der äquivalente Leistung und konstanter Drehzahl, erfolgt die Getriebeauslegung dann wie die Getriebeauswahl gemäß dem in diesem Katalog beschriebenen Verfahren für konstante Leistung.

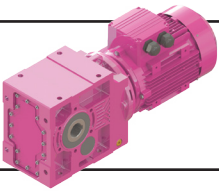

# Genel Bilgiler

## General Information

### Einführung



#### Redüktör Seçimi

Bir redüktör seçiminde aşağıdaki yol izlenmelidir.

1. Çalışma şartlarına bağlı olarak servis faktörünü (fs) belirleyiniz. (Servis Faktörü Sayfa 16).

2. Makinanız için gerekli olan momenti belirleyiniz  $M_2$  (redüktör gerekli çıkış momenti ).

3. Makinanızın devrini belirleyiniz  $n_2$  (redüktör gerekli çıkış devri ).

4. Makinanızın güç ihtiyacını (Redüktör çıkış gücünü) " $P_2$ " hesaplayınız.

$$P_2 = \frac{M_2 \times n_2}{9550}$$

5. Redüktör ile makina arasında kullanılan bağlantı elemanına göre radyal yükü hesaplayınız. (Sayfa 20). Yukarıdaki verilere uygun olarak çıkış devri, değerlerine uyan servis faktörü ve radyal yükü bulduğunuzdan daha yüksek veya eşit olan redüktörü, güç-devir seçim tablolarından seçiniz. Helisel tip redüktörlerde verim yüksek olduğundan çıkış gücü verilmemiştir. Hesapladığınız güç değerini giriş gücü olarak kabul edip seçiminizi yapınız. Tablolarda verilen  $M_2$  çıkış momentinin hesapladığınız  $M_2$  den büyük olmasına dikkat ediniz. Eğer seçilen redüktörünki daha ufak ise bir üst motor gücüne geçiniz.

#### Örnek

##### 1. Makina Cinsi:

Lastik bantlı konveyör , dökme yük taşıyor.

##### 2. Makina için gerekli moment:

Makina için hesaplanan moment  $M_2 = 470$  Nm.

##### 3. Makina gerekli çıkış devri:

$n_2 = 50$  dev/dak.

##### 4. Günlük çalışma süresi:

16 saat.

##### 5. Saatte start sayısı:

Saatte 1 start

##### 6. Makina ile bağlantı şekli:

Zincir dişli ( çap -130 mm )

- Yük sınıflandırma tablosundan yük sınıfı M olarak seçilir (sayfa 17-18)

- Günlük çalışma süresi 16 saat Saatte start sayısı 1 ve yük sınıfı M'ye tekabül eden servis faktörü tablosundan, servis faktörü için  $fs = 1.3$  değeri bulunur.(sayfa 16)

- Makinanızın güç ihtiyacı (Redüktör Çıkış Gücü) :

$$P_2 = \frac{M_2 \times n_2}{9550} = \frac{470 \times 50}{9550} = 2,46 \text{ kW}$$

#### Gearbox Selection

For the correct selection of the appropriate gear units follow this steps.

1.Determine service factor (fs) on the basis of running conditions (Page 16).

2. Determine the required Torque  $M_2$  (required output torque of gearbox) for the driven machine.

3. Determine required speed (output speed of gearbox) for the driven machine.

4. Calculate the required power for your machine(Calculate power " $P_2$ " required at output side of gear reducer using the formula);

$$P_2 = \frac{M_2 \times n_2}{9550}$$

5. Calculate overhung load required at output shaft according to type of connection between gear unit and machine (Refer to directions and values given on page 20). After determining the above mentioned values, the gear reducer which corresponds to our requirements can be selected from the performance tables (the service factor and the permissible overhung load should be less than or equal to our requirement). For Helical gears the output power is not given on the performance tables because they have high efficiency and the output power can be taken as input power. The output torque should be checked if it meets to our requirements. If the output torque is low, search for a higher input power gearbox.

#### Example:

##### 1. Machine Type:

Belt Conveyor (Bulk Load)

##### 2. Required Torque:

Required Torque calculated for the driven machine is  $M_2=470$  Nm.

##### 3. Required speed:

$n_2 = 50$  rpm

##### 4. Running time:

16 hours per day

##### 5. Frequency of starting:

1 start per hour

##### 6. Connection type between gear reducer

Chain drive (output dimension-130 mm)

- From the load classification table (on page 17-18), the load class M can be selected for the known application.

- The service factor can be selected as  $fs = 1,3$  from the service factor table (page 16) by taking into consideration 16 hours running time, one start per hour, and load class M.

-Required power for your machine(Power at output side of gear reducer) :

$$P_2 = \frac{M_2 \times n_2}{9550} = \frac{470 \times 50}{9550} = 2,46 \text{ kW}$$

#### Getriebeauswahl

Für die korrekte Auswahl des Antriebes;

1. Den Betriebsfaktor(fs) in Abhängigkeit von den Betriebsbedingungen bestimmen.(Bezug auf Seite 16).

2. Die erforderte Drehmoment  $M_2$  für die angetriebene Maschine (Abtriebsdrehmoment für die Getriebe) bestimmen.

3. Erforderte Drehzahl bestimmen (Abtriebsdrehzahl für die Getriebe).

4. Berechnen der erforderte Leistung der angetriebene Maschine (Die an der Abtriebswelle erforderte Leistung " $P_2$ ") mit der unten angegebenen Formel.

$$P_2 = \frac{M_2 \times n_2}{9550}$$

5. Die an der Getriebeabtriebswelle erforderte Querkraft in Abhängigkeit von Antriebsselement bestimmen (Bezug auf Seite 20). Nach Bestimmen der oben angegebenen Werte, die passende Getriebe kann von den angegebenen Leistungstabellen entnommen werden. Dabei soll darauf geachtet werden, dass der Betriebsfaktor und Querkraft stets unterhalb von angegebenen Werten liegt. Weil Stirnradgetrieben einen hohen Wirkungsgrad haben, sind die Abtriebsleistungen für Stirnradgetrieben nicht angegeben. Bei dieser Getrieben die erforderte Leistung kann als Antriebsleistung benutzt werden. Achten sie darauf, dass der Abtriebsmoment größer als die erforderte Drehmoment ist.

#### Beispiel:

##### 1. Maschinentyp:

Gurtbandförderer (Schüttgut)

##### 2. Erforderte Drehmoment:

Für die Maschine berechnete Drehmoment  $M_2 = 470$  Nm.

##### 3. Erforderte Drehzahl:

$n_2 = 50$  upm

##### 4. Betriebsdauer:

16 stunden pro Tag

##### 5. Schalthäufigkeit:

1 Start pro Stunde

##### 6. Antriebselement für verbindung

Getriebe-Machine:Kettentrieb(Durchmesser-130 mm)

- Von den Belastungsart Tabellen(Seite 17-18) nimmt man Belastungsart M

- Für den Schaltungszahl 1 und die Laufzeit16 und für den passenden Belastungsart erhält man Betriebsfaktor  $fs = 1,3$  von Tabelle auf Seite 16.

- Erforderte Leistung der angetriebe Maschine (Die an der Getriebeabtriebswelle erforderte Leistung)

$$P_2 = \frac{M_2 \times n_2}{9550} = \frac{470 \times 50}{9550} = 2,46 \text{ kW}$$

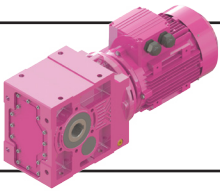

## Genel Bilgiler General Information Einführung



- Zincir dişli uygulaması için (Sayfa 21) Fq değeri;

$$F_q = \frac{2100 \times M_2}{D} = \frac{2100 \times 470}{130} = 7592 \text{ N}$$

- Ortaya çıkan redüktör ihtiyacı

$$\begin{aligned} P_2 &\geq 2,46 \text{ kW} \\ M_2 &\geq 470 \text{ Nm} \\ fs &\geq 1.3 \\ n_2 &\approx 50 \text{ d/dak} \\ F_q &\geq 7592 \text{ N} \end{aligned}$$

Güç ve devir sayfalarından,

**KR373-3E100L/4D** seçilir (Sayfa 71).

$$\begin{aligned} P_2 &= 3 \text{ kW} > 2,46 \text{ kW} \\ M_2 &= 537 \text{ Nm} > 470 \text{ Nm} \\ fs &= 1,5 \\ n_2 &= 50 \text{ d/dak} \\ fq &= 14875 \text{ Nm} > 7592 \text{ Nm} \\ i &= 28,85 \end{aligned}$$

- For chain drive application the requested overhang load can be calculated from (page 21);

$$F_q = \frac{2100 \times M_2}{D} = \frac{2100 \times 470}{130} = 7592 \text{ N}$$

- The required gearbox is as follows:

$$\begin{aligned} P_2 &\geq 2,46 \text{ kW} \\ M_2 &\geq 470 \text{ Nm} \\ fs &\geq 1.3 \\ n_2 &\approx 50 \text{ rpm} \\ F_q &\geq 7592 \text{ N} \end{aligned}$$

From the performance table,

**KR373-3E100L/4D** selected (Page 71).

$$\begin{aligned} P_2 &= 3 \text{ kW} > 2,46 \text{ kW} \\ M_2 &= 537 \text{ Nm} > 470 \text{ Nm} \\ fs &= 1,5 \\ n_2 &= 50 \text{ d/dak} \\ fq &= 14875 \text{ Nm} > 7592 \text{ Nm} \\ i &= 28,85 \end{aligned}$$

- Für Kettentrieb die erforderte Querkraft (seite 21);

$$F_q = \frac{2100 \times M_2}{D} = \frac{2100 \times 470}{130} = 7592 \text{ N}$$

- Von den oben angegebenen Berechnungen die erforderte Getriebe ist wie folgt;

$$\begin{aligned} P_2 &\geq 2,46 \text{ kW} \\ M_2 &\geq 470 \text{ Nm} \\ fs &\geq 1.3 \\ n_2 &\approx 50 \text{ U/min} \\ F_q &\geq 7592 \text{ N} \end{aligned}$$

Von der Leistung- DrehzahlTabelle ,

wurde **KR373-3E100L/4D** gewählt (Seite 71).

$$\begin{aligned} P_2 &= 3 \text{ kW} > 2,46 \text{ kW} \\ M_2 &= 537 \text{ Nm} > 470 \text{ Nm} \\ fs &= 1,5 \\ n_2 &= 50 \text{ d/dak} \\ fq &= 14875 \text{ Nm} > 7592 \text{ Nm} \\ i &= 28,85 \end{aligned}$$

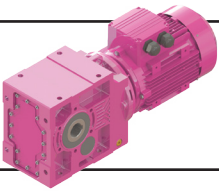

# Genel Bilgiler

## General Information

### Einführung



### Redüktör Seçim Formu

Kullanıldığı Sektör.....  
Kullanıldığı Yer.....  
Gerekli Ortalama Devir.....d/dak

#### Makina ihtiyaç gücü:

-Normal..... kW  
-En çok..... kW  
-En az..... kW

#### Tahrik Şekli:

AC Motor [ ]  
AC Motor + Invertör [ ]  
DC Motor [ ]  
Hidromotor [ ]  
1-3 silindri içten yanmalı [ ]  
2-4 silindri içten yanmalı [ ]

#### Motor Bağlantı Şekli (Elektrik Motorları):

IEC B5 Flanşlı [ ]  
NEMA Flanşlı [ ]

IEC veya NEMA flanş kodu.....

#### Motor Gücü:

-Nominal..... kW

#### Motor Devri:

-Normal..... d/dak  
-En çok..... d/dak  
-En az..... d/dak

#### Motor Torku:

-Normal..... Nm  
-En çok..... Nm  
-En az..... Nm

#### Dönüş şekli:

saat yönü [ ] saat yönüne ters [ ] değişken [ ]

#### Günlük çalışma süresi:

<4 [ ] 4-8 [ ] 8-16 [ ] >16 [ ]

#### Saatteki start sayısı:

0-50 [ ] 50-100 [ ] 100-200 [ ]  
200-300 [ ] 300-500 [ ] 500-700 [ ]  
700-1000 [ ] >1000 [ ]

Motor Redüktör Arası Tahvil Oranı.....

Kalkış için gerekli moment.....Nm

#### Saatteki pik moment adedi:

1-5 [ ] 6-30 [ ] 31-100 [ ] >100 [ ]

#### Bir çevrimde aktif çalışma oranı (ED):

%100 [ ] %80 [ ] %60 [ ] 40% [ ] %20 [ ]

#### Deniz seviyesinden yükseklik:

<1000 [ ] <2000 [ ] <3000 [ ]  
<4000 [ ] <5000 [ ]

#### Montaj yeri:

Küçük kapalı oda (w<1m/sn) [ ]  
Kapalı oda (w<3m/sn) [ ]  
Büyük oda ve holler (w>=3m/sn) [ ]  
Tamamen açık ortam [ ]

#### Çevre Şartları:

Normal [ ] Tozlu [ ] Nemli [ ]  
Korozif [ ] Kuru [ ]

#### Çevre Sıcaklığı:

Ortalama..... °C  
En Yüksek..... °C  
En Düşük..... °C

#### Kilit İhtiyacı:

Var [ ] Yok [ ]

#### Redüktör Giriş Opsiyonu:

R.. [ ] V.. [ ] N.. [ ] T.. [ ]

#### Redüktör Çıkış Opsiyonu:

00 [ ] 01 [ ] 02 [ ] 03 [ ] 04 [ ] 05 [ ] 08 [ ]  
0S [ ] 0E [ ]

#### Montaj Pozisyonu:

M1 [ ] M2 [ ] M3 [ ] M4 [ ] M5 [ ] M6 [ ]

#### Giriş mili bağlantı şekli:

Elastik kaplin [ ]  
Fıçı tipi kaplin [ ]  
Rijit kaplin [ ]  
Hidrolik Kaplin [ ]  
Kayış kasnak [ ]  
Zincir dişli [ ]  
Pinyon dişli [ ]  
Bağlantı elemanı çapı.....mm  
Radyal yükü.....N  
Radyal yük "u" mesafesi.....mm  
Aksiyal yükü (mile doğru +).....N

#### Çıkış mili bağlantı şekli:

Elastik kaplin [ ]  
Fıçı tipi kaplin [ ]  
Rijit kaplin [ ]  
Kayış kasnak [ ]  
Zincir dişli [ ]  
Pinyon dişli [ ]  
Delik milli tork kolu [ ]  
Sıkma bilezikli tork kolu [ ]  
Bağlantı elemanı çapı.....mm  
Radyal yükü.....N  
Radyal yük "u" mesafesi.....mm  
Aksiyal yükü (mile doğru +).....N

#### Çıkış Mili Özelliği:

Dolu Mil Kamalı [ ]  
Dolu Mil Kamasız [ ]  
Delik Milli Sıkma Bilezikli [ ]  
Delik Milli [ ]  
Özel Mil [ ]

#### Giriş Mili Özelliği:

Kamalı [ ]  
Kamasız düz mil [ ]  
Özel Mil [ ]  
Tork kolu [ ] Var [ ] Yok [ ]

#### Elektrik Gerilimi:

AC-Monofaze [ ] AC-Trifaze [ ] DC [ ]  
Voltaj..... Volt  
Frekans..... Hz

#### Koruma Sınıfı:

IP55 [ ] IP65 [ ] Exproof [ ]  
Diğer IP.....

#### Ekler:

Yük diyagramı [ ]  
Proje [ ]  
İstenen ana boyutlar [ ]  
Teknik veriler [ ]

#### Diğer Notlar:

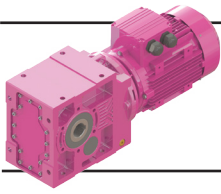

# Genel Bilgiler

## General Information

### Einführung



#### Gearbox Selection Form

Field of Industry.....  
 Application.....  
 Required Average Speed..... rpm

#### Required Power on Driven Machine:

-Normal..... kW  
 -Maximum..... kW  
 -Minimum..... kW

#### Driving Machine:

AC Motor [ ]  
 AC Motor + Inverter [ ]  
 DC Motor [ ]  
 Hydraulic Motor [ ]  
 Piston Engine with 1-3 cylinder [ ]  
 Piston Engine with 4-24 cylinder [ ]

#### Motor Connection Type (Electric Motors):

IEC B5 Flange [ ]  
 NEMA Flange [ ]

IEC or NEMA Flange Code.....

#### Motor Power:

-Nominal.....kW

#### Motor Speed:

-Normal.....rpm  
 -Maximum.....rpm  
 -Minimum.....rpm

#### Motor Torque:

-Normal.....Nm  
 -Maximum.....Nm  
 -Minimum.....Nm

#### Direction of Rotation:

cw [ ] ccw [ ] variable [ ]

#### Working hours per day:

<4 [ ] 4-8 [ ] 8-16 [ ] >16 [ ]

#### Startings per cycle:

0-50 [ ] 50-100 [ ] 100-200 [ ]  
 200-300 [ ] 300-500 [ ] 500-700 [ ]  
 700-1000 [ ] >1000 [ ]

Transmission ratio between motor and gear unit.....

Required Starting Torque.....Nm

#### Peak torques per hour:

1-5 [ ] 6-30 [ ] 31-100 [ ] >100 [ ]

#### Effective working time in a cycle (ED):

%100 [ ] %80 [ ] %60 [ ] 40% [ ]  
 20% [ ]

#### Altitude:

<1000 [ ] <2000 [ ] <3000 [ ]  
 <4000 [ ] <5000 [ ]

#### Mounting Place:

Small closed room (w<1m/sn) [ ]  
 Closed room (w<3m/sn) [ ]  
 Big rooms and halls (w>=3m/sn) [ ]  
 Outdoor [ ]

#### Ambient Conditions:

Normal [ ] Dusty [ ] Humid [ ]  
 Corrosive [ ] Dry [ ]

#### Ambient Temperature:

Average.....°C  
 Maximum.....°C  
 Minimum.....°C

#### Backstop Required:

Yes [ ] No [ ]

#### Gearbox input options:

R.. [ ] V.. [ ] N.. [ ] T.. [ ]

#### Gearbox output options:

00 [ ] 01 [ ] 02 [ ] 03 [ ] 04 [ ] 05 [ ] 08 [ ]  
 0S [ ] 0E [ ]

#### Mounting Position:

M1 [ ] M2 [ ] M3 [ ] M4 [ ] M5 [ ] M6 [ ]

#### Input Shaft Connection Type:

Elastic Coupling [ ]  
 Barrel Type Coupling [ ]  
 Hydraulic Coupling [ ]  
 Rigid Flange Coupling [ ]  
 Pulley [ ]  
 Chain Sprocket [ ]  
 Pinion [ ]  
 Diameter of Connection element.....mm  
 Radial Load.....N  
 "u" Distance of Radial Load.....mm  
 Axial Load (Towards Shaft) .....N

#### Output Shaft Connection Type:

Elastic Coupling [ ]  
 Barrel Type Coupling [ ]  
 Rigid Flange Coupling [ ]  
 Pulley [ ]  
 Chain Sprocket [ ]  
 Pinion [ ]  
 Hollow Shaft with Torque Arm [ ]  
 Shrinck disc with Torque Arm [ ]  
 Diameter of Connection Element.....mm  
 Radial Load.....N  
 "u" Distance of Radial Load.....mm  
 Axial Load (Towards Shaft) .....N

#### Gearbox assembled by:

Foot [ ] Flange [ ] Torque Arm [ ]

#### Output Shaft Specification:

Solid Shaft with Keyway [ ]  
 Solid Shaft without Keyway [ ]  
 Hollow Shaft with Shrinck Disc [ ]  
 Hollow Shaft [ ]  
 Special Shaft [ ]

#### Input Shaft Specification:

Solid Shaft with Keyway [ ]  
 Solid Shaft without Keyway [ ]  
 Special Shaft [ ]  
 Torque arm required Yes [ ] No [ ]

#### Electrical Supply:

AC-1 Phase [ ] AC-3 Phase [ ] DC [ ]  
 Voltage.....Volt  
 Frequency..... Hz

#### Protection Class:

IP55 [ ] IP65 [ ] Exproof [ ]  
 Other IP.....

#### Attachments:

Load Diagram [ ]  
 Project [ ]  
 Required Dimensions [ ]  
 Technical Specifications [ ]

#### Notes:

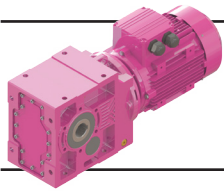

# Genel Bilgiler

## General Information

### Einführung



#### Formular für Getriebeauswahl

Industriebereich.....  
 Anwendung.....  
 Erforderliche Drehzahl.....U/min

#### Erforderliche Leistung für die Maschine:

-Normal.....kW  
 -Minimal.....kW  
 -Maximal.....kW

#### Antriebsmaschine:

AC Motor [ ]  
 AC Motor mit Frequenzumrichter [ ]  
 DC Motor [ ]  
 Hydromotor [ ]  
 Kolbenmaschinen mit 1-3 Zylinder [ ]  
 Kolbenmaschinen mit 2-4 Zylinder [ ]

#### Motorverbindungsart (Elektromotoren):

IEC B5 Flansch [ ]  
 NEMA Flansch [ ]

IEC oder NEMA Flanschcode.....

#### Motorleistung:

-Nominal.....kW

#### Motordrehzahl:

-Normal.....U/min  
 -Maximal.....U/min  
 -Minimal.....U/min

#### Motordrehmoment:

-Normal.....Nm  
 -Maximal.....Nm  
 -Minimal.....Nm

#### Drehrichtung:

in Uhrzeigersinn [ ] gegen Uhrzeigersinn [ ]  
 veränderlich [ ]

#### Betriebsdauer in Stunden pro Tag:

<4 [ ] 4-8 [ ] 8-16 [ ] >16 [ ]

#### Anzahl der Anläufe pro Stunde:

0-50 [ ] 50-100 [ ] 100-200 [ ]  
 200-300 [ ] 300-500 [ ] 500-700 [ ]  
 700-1000 [ ] >1000 [ ]

Übersetzung zwischen Motor und Antriebswelle.....

Erforderliches Anlaufmoment.....Nm

#### Häufigkeit von Lastspitzen pro Stunde:

1-5 [ ] 6-30 [ ] 31-100 [ ] >100 [ ]

#### Einschaltdauer je Stunde (ED):

%100 [ ] %80 [ ] %60 [ ] 40% [ ] %20 [ ]

#### Höhenlage über Meeresspiegel (m):

<1000 [ ] <2000 [ ] <3000 [ ]  
 <4000 [ ] <5000 [ ]

#### Betriebsort:

Kleine geschlossene Räume (w<1m/sn) [ ]  
 Geschlossene Räume (w<3m/sn) [ ]  
 Große Räume und Hallen (w>=3m/sn) [ ]  
 im Freien [ ]

#### Umgebungsbedingungen:

Normal [ ] Staubig [ ] Feucht [ ]  
 Korrodierend [ ] Trocken [ ] Verklebend [ ]

#### Umgebungstemperatur:

Mittelwert.....°C  
 Maximal.....°C  
 Minimal.....°C

#### Rücklauf Sperre erforderlich:

Ja [ ] Nein [ ]

#### Getriebeeingangsvarianten:

R.. [ ] V.. [ ] N.. [ ] T.. [ ]

#### Getriebeausgangsvarianten:

00 [ ] 01 [ ] 02 [ ] 03 [ ] 04 [ ] 05 [ ] 08 [ ]  
 0S [ ] 0E [ ]

#### Montageposition:

M1 [ ] M2 [ ] M3 [ ] M4 [ ] M5 [ ] M6 [ ]

#### Antriebswellenanschluss:

Elastische Kupplung [ ]  
 Trommelkupplung [ ]  
 Hydrokupplung [ ]  
 Starre Flanschkupplung [ ]  
 Riementrieb [ ]  
 Kettenrad [ ]  
 Ritzel [ ]  
 Durchmesser von Anschlusselement.....mm  
 Querkraft.....N  
 "u" Abstand von der Wellenschulter.....mm  
 Axialkraft (in Richtung der Welle +) .....N

#### Abtriebswellenanschluss:

Elastische Kupplung [ ]  
 Trommelkupplung [ ]  
 Starre Flanschkupplung [ ]  
 Riementrieb [ ]  
 Kettenrad [ ]  
 Ritzel [ ]  
 Hohlwelle mit Drehmomentstütze [ ]  
 Schrumpfscheibe mit Drehmomentstütze [ ]  
 Durchmesser von Anschlusselement.....mm  
 Querkraft.....N  
 "u" Abstand von der Wellenschulter.....mm  
 Axialkraft (in Richtung der Welle +) .....N

#### Montage zur Getriebegehäuse mit:

Fuß [ ] Flansch [ ] Drehmomentstütze [ ]

#### Eigenschaften der Abtriebswelle:

Vollwelle mit Passfeder [ ]  
 Vollwelle ohne Passfeder [ ]  
 Hohlwelle mit Schrumpfscheibe [ ]  
 Hohlwelle [ ]  
 Sonderwelle [ ]

#### Eigenschaften der Antriebswelle:

Vollwelle mit Paßfeder [ ]  
 Vollwelle ohne Paßfeder [ ]  
 Sonderwelle [ ]  
 Drehmomentstütze erforderlich Ja [ ] Nein [ ]

#### Spannungsversorgung:

AC-1 phasig [ ] AC-3 phasig [ ] DC [ ]  
 Spannung.....Volt  
 Frequenz.....Hz

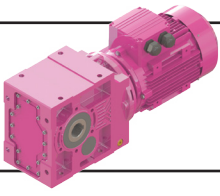

# Genel Bilgiler

## General Information

### Einführung



#### Yağlama

Redüktörlerin uzun ömürlü olması ve iyi performansla çalışabilmesi için, kullanılan yağın seçimi doğru olmalı ve belirtilen zamanlarda değişimleri yapılmalıdır.

Yağın seçiminde devir, çevre sıcaklığı, redüktör yağ sıcaklığı, çalışma koşulları ve yağ ömrü önem taşımaktadır. Redüktörler yağlı doldurulmuş olarak sevkedilmektedir. Redüktörler uzun süre depolanacakları zaman veya çalışmaya başlanacağı zaman çalışma konumuna göre üstte kalan tapa sökülmesi ve redüktörün beraberinde verilen havalandırma tapası kullanılmalıdır. Bu redüktörün iç basıncından dolayı oluşacak yağ sızmalarını önleyecektir.

Redüktörlerde standart olarak kullanılan yağlar 33. sayfadaki tabloda verilmiştir. Miktarlar ve yağ tipi burada verilen değerlerden farklılık gösterebilir. Redüktörünüzde kullanılan yağın tipi ve miktarı için lütfen etiketine bakınız. Ayaklı redüktörler ve flanşlı redüktörler M1 pozisyonuna göre yağ ile doldurulmuştur. Bu pozisyonlar dışındaki çalışma durumlarında tablolarda verilen yağ miktarlarına göre ilave veya eksiltme yapılmalıdır. Özel çalışma koşullarında firmamıza danışmanız tavsiye edilir.

Mineral yağlar her 10.000 çalışma saatinde, sentetik yağlar ise her 20.000 çalışma saatinde değiştirilmelidir. Ağır çevre koşullarında (ani ısı değişiklikleri, yüksek nemlilik v.b) yağ değiştirme periyotlarının kısaltılması tavsiye edilir. Mineral yağlar ile sentetik yağlar birbirine kesinlikle karıştırılmamalıdır. Değiştirme işlemi bir çalışma periyodunun hemen peşinden ve yağ sıcakken yapılmalıdır. Bu şekilde bir değiştirme, redüktör içindeki partiküllerin yağa karışmış olarak bulunmasından dolayı iyi bir temizleme ve yağın rahat boşalması neticesini verecektir.

#### Lubrication

*To work in perfect condition and to have long life for the gear box the lubricant must be chosen correctly and changed in time.*

*In selection of oil it is important to consider speed, ambient temperature, gear box oil temperature, working conditions and the life required from the lubricant. All units are filled with lubricant before shipping. Before the gearbox is stored for a long time or before starting up, the top plug (according to the working position) must be removed and the extra given vent plug must be replaced. This prevents excessive pressure which causes oil leakages.*

*The lubricant in the standard line is given for standard fillings on the table on page 33. Please look at your gear units label for filled oil type and quantity. The foot mounting type gear boxes and where the flange mounted gear boxes are filled for mounting position of M1. For other mounting positions please refer to the table given on the next pages. For special working conditions please contact us.*

*The mineral lubricant should be changed after every 10.000 service hours and the synthetic lubricant should be changed after every 20.000 working hours. If the operation conditions are very heavy (e.g. high temperature differences, high humidity) shorter intervals between changes are recommended. Mineral and synthetic oils must not be mixed up. By changing the lubricant complete cleaning is advised. The oil change should be done after a working period. Because oil is hot in this condition and impurities are mixed with it the changing of oil will be done in best result and the oil will drain easily.*

#### Schmierung

Um eine lange Lebensdauer zu gewährleisten muss der Schmierstoff richtig ausgewählt werden.

Für die richtige Ölauswahl müssen Drehzahl, Umgebungstemperatur, Belastungsart und Lebensdauer des Öls berücksichtigt werden. Die mitgelieferte Entlüftungsschraube ist vor Inbetriebnahme oder längeren Lagern gegen die Einfüllschraube auszutauschen, um einen Überdruck im Getriebe und damit eine Undichtigkeit des Getriebes zu vermeiden. Getriebe und Getriebemotoren sind bei Auslieferung betriebsfertig gefüllt.

Ohne besondere Bestellangaben werden die Getriebe grundsätzlich mit den auf der Seite 33 in der grau unterlegten Spalte angegebenen Schmierstoffen gefüllt. Bitte im Getriebe verwendetes Öl und menge von dem Namensschild ablesen. Die fußbefestigten Getriebe sind befüllt für Bauform und die flanschbefestigten Getriebe für Bauform M1. Für andere Bauformen sind die auf der nächsten Seite angegebenen Füllmengen zu beachten.

Ein Schmierstoffwechsel sollte alle 10.000 Betriebsstunden durchgeführt werden. Für synthetische Produkte verdoppeln sich diese Fristen. Bei extremen Betriebsbedingungen, z.B. hohe Luftfeuchtigkeit, aggressiver Umgebung und hohen Temperaturschwankungen sind kürzere Schmierstoffintervalle vorteilhaft. Es ist empfehlenswert, dem Schmierstoffwechsel mit einer gründlichen Reinigung des Getriebes zu verbinden. Synthetische und mineralische Schmierstoffe dürfen nicht miteinander vermischt werden. Das Ablassen des Öls soll unmittelbar nach dem Stillsetzen erfolgen, solange das Öl noch warm ist. In dieser Zustand ist das Öl mit den Schmutzpartikeln vermischt, so dass eine Entfernung des Altöls eine gute Reinigung garantiert.

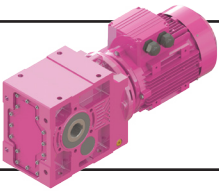

## Genel Bilgiler General Information Einführung



### M4 Montaj Pozisyonu için Genleşme Tankı / Expansion Tank for M4 Mounting Position / Ölausgleichsbehälter für M4 Bauform

Aşağıdaki teknik resimde gösterildiği gibi montaj pozisyonları **M4** (montaj pozisyonları syf.34) olan redüktörlerde düzgün bir yağlama sağlanabilmesi için yağ seviyesinin redüktörün üst dişlilerinin yağlanabileceği seviyede olması gerekmektedir. Buda düşük çevrim oranlı redüktörlerde köpürme ve genleşme nedeniyle havalandırma tapasından yağ atılmasına neden olabilmektedir.

Yılmaz redüktör; bunun önlenmesi için çevrim oranı  $(i) < 20$  ve K47'den daha büyük olan bütün gövdelerde **M4** montaj pozisyonunda genleşme tankı kullanılmasını kesinlikle önermektedir. Önerilen genleşme tankı ölçüleri aşağıdaki tabloda gösterilmiştir.

Çevrim oranı  $(i) < 20$  olup giriş motor devri 1800 d/d dan büyük olan bütün redüktörlerde **M4** montaj pozisyonunda genleşme tankı kullanılması redüktör büyüklüğüne bakılmaksızın önerilmektedir.

*As you can see at the technical drawing below, for gear units with **M4** (mounting positions p. 34) mounting position, oil level is very high for proper lubrication of upper pinion gear and this leads to oil leakage from venting plug, because of foaming and expansion of oil at geared motors with ratios below 20.*

*We ; Yılmaz Redüktör, strongly recommend using expansion tank for **M4** mounting position for gear units K57, K67, K77 and K87 with total ratios  $(i)$  below 20, to prevent this. You can find the recommended dimensions of expansion tanks below.*

*If your gear units total ratio  $(i)$  is below 20 and input speed is higher than 1800 rpm we recommend using of expansion tank for all gear unit sizes for **M4** mounting position.*

Wie in der folgenden technischen Zeichnung dargestellt ist, sollte der Ölstand auf der gleichen Höhe der ersten Getriebestufe sein, um eine ausreichende Schmierung des oberen Zahnrads bei der **M4** Bauform (s. Seite 34) sicher zu stellen. Aufgrund dieses hohen Ölstands bildet sich Ölschaum aus, welcher aus der Entlüftungsschraube austritt.

Um das verhindern zu müssen, empfiehlt Yılmaz Redüktör bei allen K-Serie Getrieben ab Getriebebaugröße K57 mit niedrigen Übersetzungen ( $i < 20$ ) einen Ölausgleichsbehälter bei der **M4** Bauform einzusetzen. Die empfohlenen Dimensionen des Ölausgleichsbehälters sind in der unteren Tabelle angegeben.

Bei Getrieben mit Übersetzungen ( $i < 20$ ) und bei Motor-Eingangsdrehzahlen  $> 1800 \text{ min}^{-1}$  empfiehlt Yılmaz Redüktör einen Ölausgleichsbehälter unabhängig von der Getriebebaugröße einzusetzen.

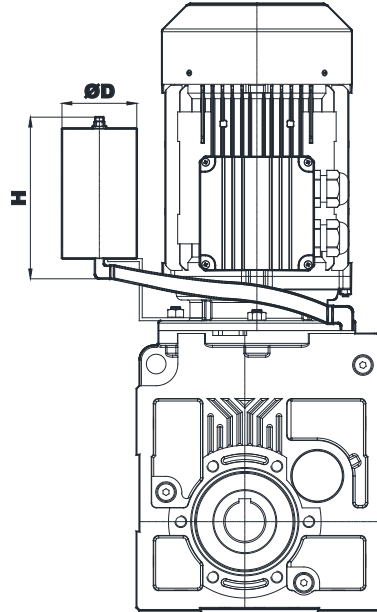

Gövde Büyüklüğü Housing Size Gehäusegröße	Genleşme Tankı Expansion Tank Ölausgleichsbehälter	D [mm]	H [mm]	Ağırlık Weight Gewicht [kg]
K57..	G1	100	150	4
K67.. , K77..	G2	150	250	5
K87..	G3	180	400	9



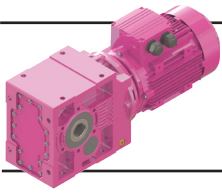

# Genel Bilgiler

## General Information

### Einführung



#### Yağ Tipleri / Oil Types / Schmierstoffe

Yağ Cinsi Lubricant Art des Schmierers	DIN 51517-3	Çevre Sıcaklığı (°C) Ambient Temperature (°C) Umgebungstemperatur (°C)		ISO VG	Aral	Beyond Petroleum	Castrol	Klüber Lubrication	Mobil	Shell	Total
		Daldırma Yağlama Dip Lubrication Tauchschrmer.	Basınçlı Yağlama Forced Lubrication Druckschrmer.								
Mineral Yağlar Mineral Oil Mineralöl	CLP	0 ... +50	-	680							
		-5 ... +45	-	460	Degol BG 460	Energol GR-XP 460	Alpha SP 460	Klüberoil GEM 1-460 N	Mobilgear 600 XP 460	Omala F460	Carter EP 460
		-10 ... +40	+15 ... +40	320	Degol BG 320	Energol GR-XP 320	Alpha SP 320	Klüberoil GEM 1-320 N	Mobilgear 600 XP 320	Omala F320	Carter EP 320
		-15 ... +30	+10 ... +30	220	Degol BG 220	Energol GR-XP 220	Alpha SP 220	Klüberoil GEM 1-220 N	Mobilgear 600 XP 220	Omala F220	Carter EP 220
		-20 ... +20	+5 ... +20	150	Degol BG 150	Energol GR-XP 150	Alpha SP 150	Klüberoil GEM 1-150 N	Mobilgear 600 XP 150	Omala 150	Carter EP 150
		-25 ... +10	+3 ... +10	100	Degol BG 100	Energol GR-XP 100	Alpha SP 100	Klüberoil GEM 1-100 N	Mobilgear 600 XP 100	Omala 100	Carter EP 100
Sentetik Yağlar Synthetic Oil Synthetisches Öl	CLP PG	-10 ... +60	-	680	Degol GS 680	Energol SG-XP 680	-	Klübersynth GH 6 -680	Mobil Glygoyle 680	Tivela S 680	Carter SY 680
		-20 ... +50	-	460	Degol GS 460	Energol SG-XP 460	Aphasyn PG 460	Klübersynth GH 6 -460	Mobil Glygoyle 460	Tivela S 460	Carter SY 460
		-25 ... +40	+5 ... +40	320	Degol GS 320	Energol SG-XP 320	Aphasyn PG 320	Klübersynth GH 6 -320	Mobil Glygoyle 320	Tivela S 320	Carter SY 320
		-30 ... +30	0 ... +30	220	Degol GS 220	Energol SG-XP 220	Aphasyn PG 220	Klübersynth GH 6 -220	Mobil Glygoyle 30	Tivela S 220	Carter SY 220
		-35 ... +20	-5 ... +20	150	Degol GS 150	Energol SG-XP 150	Aphasyn PG 150	Klübersynth GH 6 -150	Mobil Glygoyle 22	Tivela S 150	Carter SY 150
		-40 ... +10	-8 ... +10	100	-	-	-	Klübersynth GH 6 -100	Mobil Glygoyle 100	-	-
	CLP HC	-10 ... +60	-	680	-	-	-	Klübersynth GEM 4-680 N	Mobil SHC Gear 680	-	Carter SH 680
		-20 ... +50	-	460	Degol PAS 460	Energol EP-XF 460	Aphasyn T 460	Klübersynth GEM 4-460 N	Mobil SHC Gear 460	Omala HD 460	Carter SH 460
		-25 ... +40	+5 ... +40	320	Degol PAS 320	Energol EP-XF 320	Aphasyn T 320	Klübersynth GEM 4-320 N	Mobil SHC Gear 320	Omala HD 320	Carter SH 320
		-30 ... +30	0 ... +30	220	Degol PAS 220	Energol EP-XF 220	Aphasyn T 220	Klübersynth GEM 4-220 N	Mobil SHC Gear 220	Omala HD 220	Carter SH 220
		-35 ... +20	-5 ... +20	150	Degol PAS 150	Energol EP-XF 150	Aphasyn T 150	Klübersynth GEM 4-150 N	Mobil SHC Gear 150	Omala HD 150	Carter SH 150
		-40 ... +10	-8 ... +10	100	-	-	-	Klübersynth GEM 4-100 N	Mobil SHC 627	-	-
Gıda Uyumlu Yağ Food Grade Oil Lebensmittelöl	CLP NSF H1	-15 ... +25	+5 ... +25	320	-	-	Optileb GT 320	Klüberoil 4 UH1-320 N	Mobil SHC Cibus 320	Cassida Fluid GL-320	Nevastane SL 320
Çevre Dostu Yağ Biodegradable Oil Biologisch abbaubares Öl	CLP E	-25 ... +40	+5 ... +40	320	-	-	Tribol BioTop 1418-320	Klübersynth GEM 2-320	-	-	Carter Bio 320
Mineral Gresler [ -20 ... +120 °C Çalışma Sıcaklığı ] Mineral Grease [ -20 ... +120 °C Working Temperature ] Mineral-Fett [ -20 ... +120 °C Betriebstemperatur ]					Aralub HL3	Energol LS 3	Spheerol AP3	Centoplex 2 EP	Mobilux EP 3	Alvania RL3	Multis Complex EP 2
Sentetik Gresler [ -30 ... +100 °C Çalışma Sıcaklığı ] Synthetic Grease [ -30 ... +100 °C Working Temperature ] Synthetisches Fett [ -30 ... +100 °C Betriebstemperatur ]					-	Energol SY 2202	-	Petamo GHY 133 N	Mobiltemp SHC 100	Cassida RLS 2	Multis Complex SHD 220

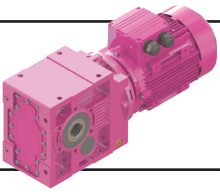

# Genel Bilgiler

## General Information

### Einführung



Montaj Pozisyonları / Mounting Positions / Bauformen

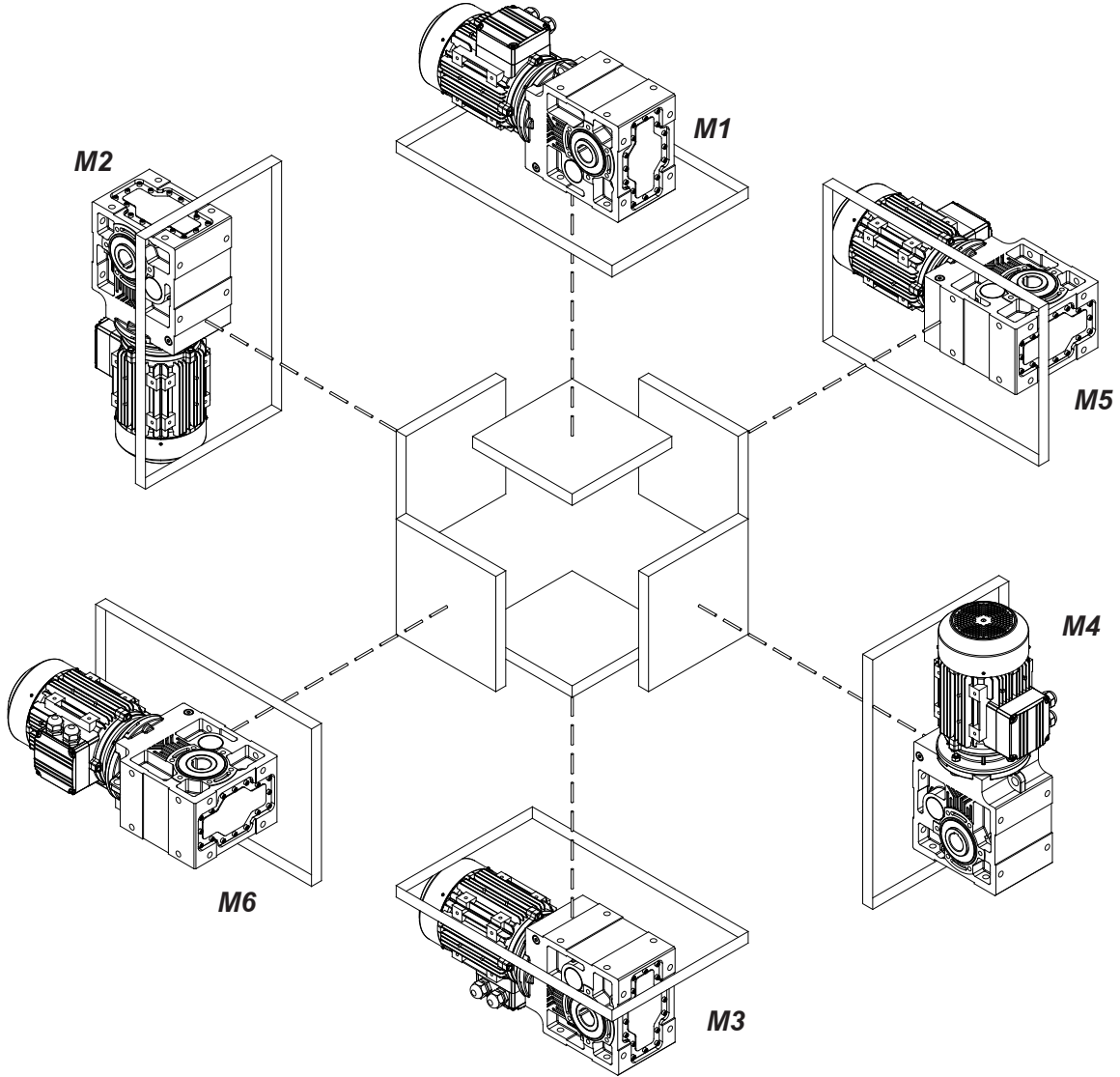

**M1....M6 'ya kadar belirtilen montaj pozisyonları redüktörün duruş yönü referans alınarak belirlenmiştir. Montaj yüzeyleri bağlayıcı değildir.**  
*Figured mounting positions of M1 to M6 are determined as reference of directional position of the gearbox. Mounting surfaces are not binding.*  
Dargestellte Montagepositionen M1 bis M6 wurden nach der Stehrichtung von Getriebe bestimmt. Montageoberflächen sind unverbindlich.

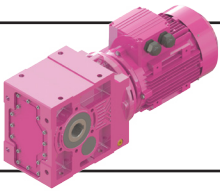

# Genel Bilgiler

## General Information

### Einführung



#### K.00. - K.20. İki - Üç Kademeli Helisel-Konik Dişli Redüktörler Yağ Seviye Tapaları

K.00. - K.20. Two - Three Stage Helical-Bevel Geared Gearboxes Oil Level Plugs

K.00. - K.20. Zwei-Dreistufige Stirn-Kegelradgetriebe Ölverschlußschrauben

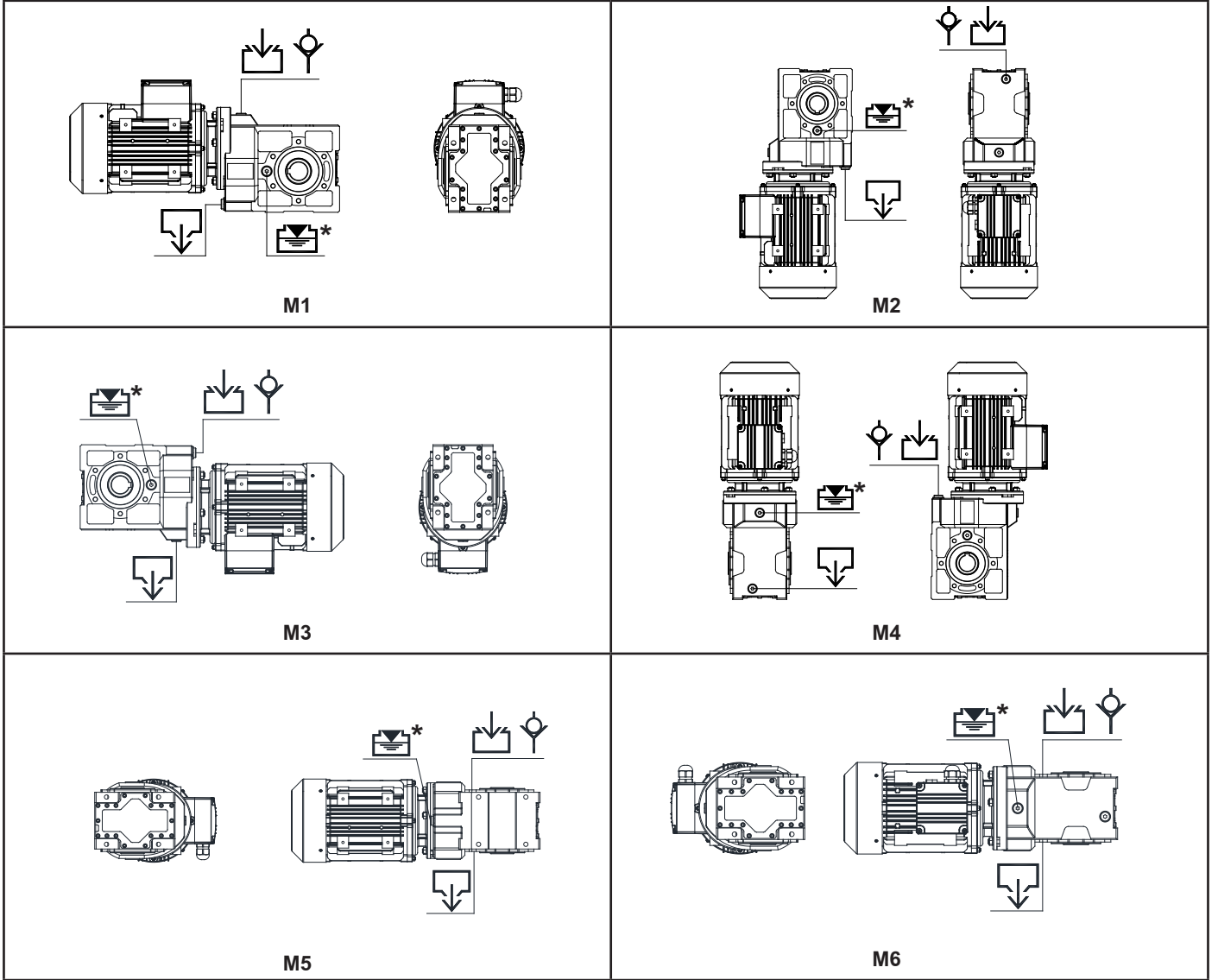

\* : K002 ve K003'de bu tapa yoktur. Lütfen yağ miktarına göre yağ koyunuz.

\* : For K002 and K003 this plug doesn't exist. Please refer to oil quantities.

\* : Bei K002 und K003 existiert diese Ölstands-schraube nicht. Bitte nach Ölmenge füllen.

#### Yağ Miktarları (lt) / Oil Quantities (lt) / Ölmengen (Liter)

Tip / Type / Typ	M1	M2	M3	M4	M5	M6
K.002	0,3	0,6	0,5	0,8	0,65	0,65
K.003	0,3	0,6	0,5	0,8	0,65	0,65
K.102	0,55	0,8	0,85	1,1	0,8	0,8
K.103	0,5	0,7	0,8	1,0	0,8	0,8
K.202	1,0	1,35	1,5	1,7	1,4	1,4
K.203	0,9	1,25	1,4	1,6	1,3	1,3

Semboller :

Symbols :

Symbole :

: Yağ boşaltma

: Drain plug

: Ölauslass

: Yağ doldurma

: Oil filling

: Ölfüllung

: Havalandırma

: Vent plug

: Entlüftungsschraube

: Yağ seviyesi

: Oil level

: Ölstand

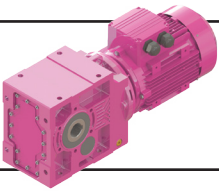

# Genel Bilgiler

## General Information

### Einführung



#### K.273 - K.873 Üç Kademeli Helisel-Konik Dişli Redüktörler Yağ Seviye Tapaları

K.273 - K.873 Three Stage Helical-Bevel Geared Gearboxes Oil Level Plugs  
K.273 - K.873 Dreistufig Stirn-Kegelradgetriebe Ölverschlußschrauben

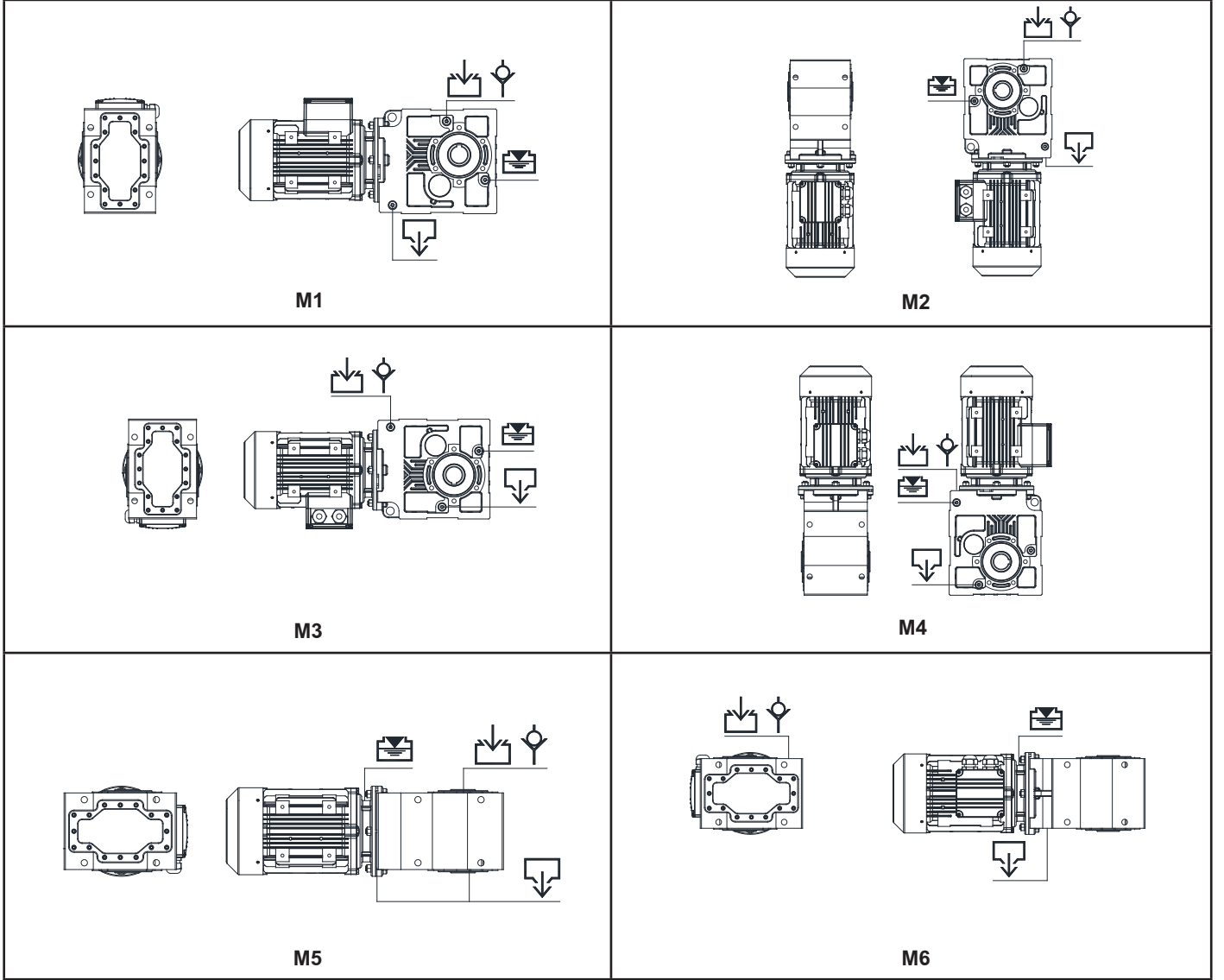

#### Yağ Miktarları (lt) / Oil Quantities (lt) / Ölmengen (Liter)

Tip / Type / Typ	M1	M2	M3	M4	M5	M6
K.273	0,8	1,8	2,2	2,3	1,4	1,5
K.373	1,4	3,3	3,4	4,0	1,9	2,2
K.473	2,7	5,9	6,5	7,8	4,0	4,5
K.573	4,1	9,0	9,7	11,5	5,5	6,6
K.673	8,7	16,3	18,0	22,5	11,7	13,2
K.773	13,0	28,0	30,0	35,0	18,0	20,0
K.873	27,0	45,0	42,0	63,0	38,0	38,0

Semboller :

Symbols :

Symbole :



: Yağ boşaltma

: Drain plug

: Ölauslass



: Yağ doldurma

: Oil filling

: Ölfüllung



: Havalandırma

: Vent plug

: Entlüftungsschraube



: Yağ seviyesi

: Oil level

: Ölstand

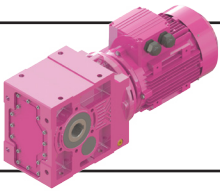

# Genel Bilgiler

## General Information

### Einführung



**K.374 - K.874 Dört Kademeli Helisel-Konik Dişli Redüktörler Yağ Seviye Tapaları**  
**K.374 - K.874 Four Stage Reduction Helical-Bevel Geared Gearboxes Oil Level Plugs**  
**K.374 - K.874 Vierstufig Stirn-Kegelradgetriebe Ölverschlußsschrauben**

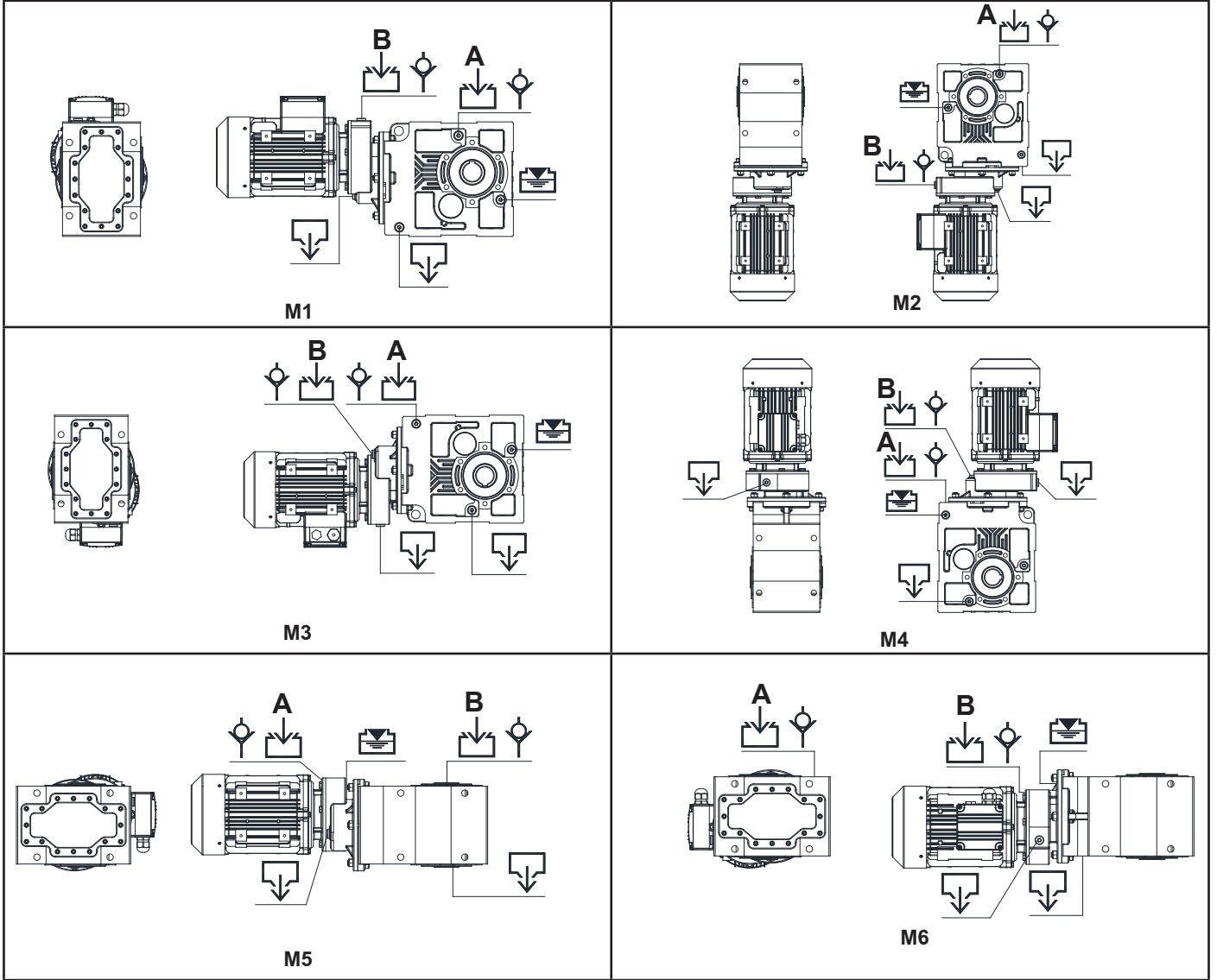

**Yağ Miktarları (lt) / Oil Quantities (lt) / Ölmengen (Liter)**

Tip / Type / Typ	M1 A / B	M2 A / B	M3 A / B	M4 A / B	M5 A / B	M6 A / B
<b>K.374</b>	1,4 / 0,25	3,3 / 0,7	3,4 / 0,25	4,0 / 0,25	1,9 / 0,25	2,2 / 0,25
<b>K.474</b>	2,7 / 0,4	5,9 / 1,5	6,5 / 0,4	7,8 / 0,4	4,0 / 0,4	4,5 / 0,4
<b>K.574</b>	4,1 / 0,5	9,0 / 1,5	9,7 / 0,5	11,5 / 0,5	5,5 / 0,5	6,6 / 0,5
<b>K.674</b>	8,7 / 0,9	16,3 / 4,0	18,0 / 0,9	22,5 / 0,9	11,7 / 0,9	13,2 / 1,0
<b>K.774</b>	13,0 / 1,0	28,0 / 4,0	30,0 / 1,0	35,0 / 1,0	18,0 / 1,0	20,0 / 1,0
<b>K.874</b>	27,0 / 2,15	45,0 / 4,0	42,0 / 2,15	63,0 / 2,15	38,0 / 2,15	38,0 / 2,15

**Semboller :**  
**Symbols :**  
**Symbole :**

 : Yağ boşaltma  
: Drain plug  
: Ölauslass

 : Yağ doldurma  
: Oil filling  
: Öfüllung

 : Havalandırma  
: Vent plug  
: Entlüftungsschraube

 : Yağ seviyesi  
: Oil level  
: Ölstand

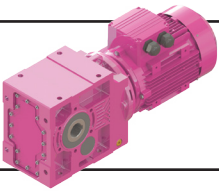

# Genel Bilgiler

## General Information

### Einführung



**K.27. - K.87. Beş-Altı Kademeli Helisel-Konik Dişli Redüktörler Yağ Seviye Tapaları**  
K.27. - K.87. Five-Six Stage Helical-Bevel Geared Gearboxes Oil Level Plugs  
K.27. - K.87. Fünf-Sechsstufig Stirn-Kegelradgetriebe Ölverschlußschrauben

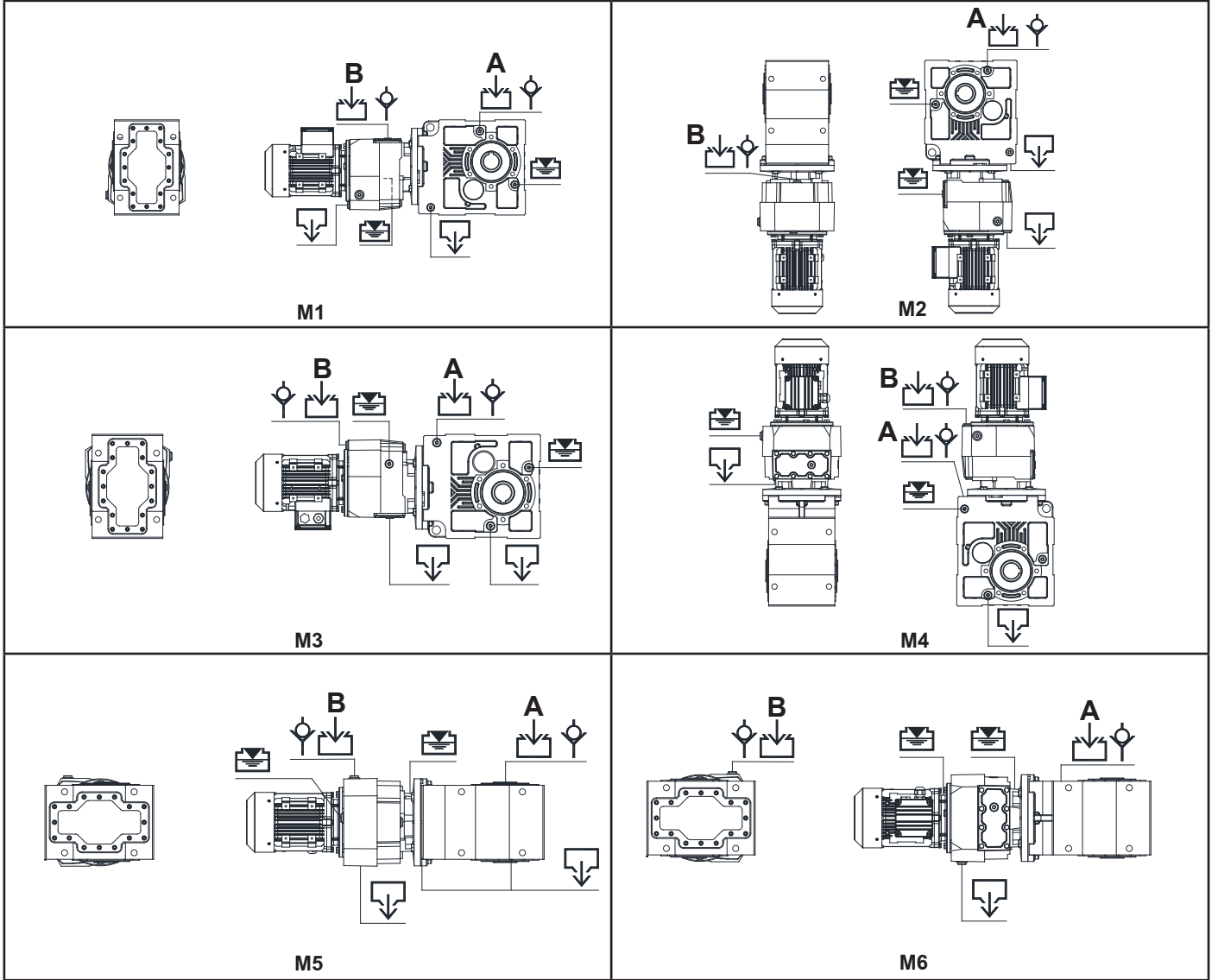

**Yağ Miktarları (lt.) / Oil Quantities. (lt) / Ölmengen (Liter)**

Tip / Type / Typ	M1 A / B	M2 A / B	M3 A / B	M4 A / B	M5 A / B	M6 A / B
K.275-276	0,8 / 0,4	1,8 / 0,4	2,2 / 0,4	2,3 / 0,4	1,4 / 0,4	1,5 / 0,4
K.375-376	1,4 / 0,7	3,3 / 0,85	3,4 / 0,7	4,0 / 0,7	1,9 / 0,7	2,2 / 0,7
K.475-476	2,7 / 1,2	5,9 / 1,9	6,5 / 1,2	7,8 / 1,2	4,0 / 1,2	4,5 / 1,2
K.575-576	4,1 / 1,2	9,0 / 1,75	9,7 / 1,2	11,5 / 1,2	5,5 / 1,2	6,6 / 1,2
K.675-676	8,7 / 2,0	16,3 / 3,1	18,0 / 2,0	22,5 / 2,0	11,7 / 2,0	13,2 / 2,0
K.775-776	13,0 / 2,0	28,0 / 3,1	30,0 / 2,0	35,0 / 2,0	18,0 / 2,0	20,0 / 2,0
K.875-876	27,0 / 2,0	45,0 / 3,1	42,0 / 2,0	63,0 / 2,0	38,0 / 2,0	38,0 / 2,0

**Semboller :**

Symbols :

Symbole :



: Yağ boşaltma

: Drain plug

: Ölauslass



: Yağ doldurma

: Oil filling

: Ölfüllung



: Havalandırma

: Vent plug

: Entlüftungsschraube



: Yağ seviyesi

: Oil level

: Ölstand

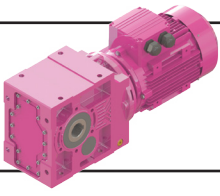

# Genel Bilgiler

## General Information

### Einführung



#### MOTORLAR

##### AC Motorlar

###### a- Genel Özellikler:

Basit konstrüksiyonlu, bakım gerektirmez, güvenilirliği yüksek ve uygun fiyatlı olmaları nedeni ile trifaze asenkron motorlar en çok kullanılan motor cinsidir. Bu motorların çalışma karakteristikleri moment-hız eğrisi ile belirlenir. Aşağıda bu karakteristik eğrisine bir örnek verilmiştir.

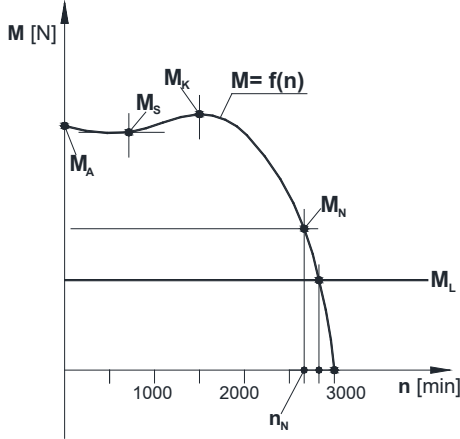

Motorun her start yapılmasında bu eğriye uygun hareket eder ve yük momenti  $M_L$  ile bu eğrinin çakıştığı nokta, motorun çalışma anındaki moment ve devirini verir.

Statorun manyetik alanı senkron hızla  $n_s$  döner. Kutuplar arasındaki faz kayması 3 fazlı motorlarda  $120^\circ$  'dir.

$$n_s = 120 \times \frac{f}{p_s}$$

$f$ .....: şebeke frekansı [Hz]  
 $p_s$ .....: statorun kutup sayısı

Rotorun değişken manyetik alanı rotorun statorun manyetik alanının dönüşü yönünde dönmeye başlamasını sağlar. Rotor bu hareketinde statorun manyetik alanını takip eder ama hiçbir zaman yakalayamaz. Rotor statorun manyetik alanının hızından yavaş döner. Rotorun bu hızına baz hız  $n_N$  denir. Yükün azalması rotorun hızının artmasını sağlar, aynı zamanda sapma azalır. Sapma aşağıdaki gibi belirlenmiştir:

$$s = \frac{n_s - n_N}{n_s} \times 100$$

Sapmanın miktarına göre motorun nominal değerlerinde şu farklılıklar olabilir.

Sapma  $s$  .....:  $\pm 20\%$   
Kalkış Akımı.....:  $\pm 20\%$   
Kalkış Momenti.....:  $-15 / +25\%$   
Kütle Atalet Momenti.....:  $\pm 10\%$   
Verim (37 kW'a kadar).....:  $-0,15 (1-\eta)$

#### MOTORS

##### AC Motors

###### a- General Specifications:

On account of its simple and maintenance free construction, good reliability and price, the three phase squirrel cage motor is one of the most frequently employed electric motors. The run up behavior of a three phase squirrel cage motor is described by the torque-speed characteristic curve. An example is shown below.

$M_A$ : Start momenti / Starting torque / Anlaufmoment

$M_S$ : Demeraj momenti / Pull-up torque / Anziehungsmoment

$M_K$ : Frenleme momenti / Pull-out torque / Bremsmoment

$M_N$ : Motorun ilettiği moment / Motor rated torque / Treibmoment

$M_L$ : Yük momenti / Load torque / Lastmoment

The motor follows this torque characteristics up to its stable operating point every time, when it is switched on. Operating point is that point, where the moment speed curve intersects with load torque  $M_L$  line.

The magnetic field in the stator rotates at a synchronous speed  $n_s$ . Phase shift of each pole is  $120^\circ$  at 3 phase motors.

$$n_s = 120 \times \frac{f}{p_s}$$

$f$ .....: supply frequency [Hz]  
 $p_s$ .....: number of stator poles

Because of the alternating magnetic field in the rotor, the rotor starts running in the same direction of the stator flux and tries to catch up with the rotating flux. The rotor never catches up the stator field. The rotor runs slower than the speed of the stator field. This speed is called the base speed  $n_N$ .

A decrease in load will cause the rotor to speed up or decrease slip. The slip is defined as follows:

$$s = \frac{n_s - n_N}{n_s} \times 100$$

According to the slip, the nominal values of the electric motor can alter as follows:

Slip  $s$  .....:  $\pm 20\%$   
Starting current .....:  $\pm 20\%$   
Starting torque .....:  $-15 / +25\%$   
Moment of inertia.....:  $\pm 10\%$   
Efficiency (up to 37 kW).....:  $-0,15 (1-\eta)$

#### MOTOREN

##### Drehstrommotoren:

###### a- Allgemeine Eigenschaften

Wegen die wartungsarme und leichte Konstruktion, hohe Sicherheit bei Nutzung und günstige Preise werden die asynchrone Drehstrommotoren am meisten benutzt. Motoranlaufverhalten wird mit Moment-Drehzahl-Kurve charakterisiert. Ein Beispiel ist unten angegeben.

Der Drehstrommotor läuft diese Kurve bei jedem Anlauf, bis dem stabilen Betriebspunkt erreicht wird. Betriebspunkt ist der Zustand, bei dem die Moment-Drehzahl-Kurve sich mit der Linie von erforderlichen Moment  $M_L$  schneidet.

Magnetisches Feld von Stator dreht sich mit synchroner Geschwindigkeit  $n_s$ . Phasenverschiebung von den Polen ist  $120^\circ$  bei 3phasigen Drehstrommotoren.

$$n_s = 120 \times \frac{f}{p_s}$$

$f$ .....: Frequenz der Spannung [Hz]  
 $p_s$ .....: Anzahl der Polen von Stator

Durch das magnetische Wechselfeld in den Rotor, beginnt der Rotor sich in der gleichen Richtung des Statorflusses zu drehen und versucht diese Bewegung aufzuholen. Der Rotor kann das Statorfeld nie aufholen. Die Rotorgeschwindigkeit nennt man Basisgeschwindigkeit  $n_N$ . Eine Abnahme der Belastung bewirkt, dass der Rotor sich beschleunigt und der Schlupf sich verringert. Der Schlupf wird wie folgt definiert:

$$s = \frac{n_s - n_N}{n_s} \times 100$$

Für die nominale Werte der Drehstrommotoren sind folgende Abweichungen zulässig:

Schlupf  $s$  .....:  $\pm 20\%$   
Anzugsstrom .....:  $\pm 20\%$   
Anzugsmoment .....:  $-15 / +25\%$   
Massenträgheitsmoment .....:  $\pm 10\%$   
Wirkungsgrad (bis 37 kW).....:  $-0,15 (1-\eta)$

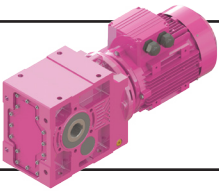

# Genel Bilgiler

## General Information

### Einführung



#### b- Çalışma Türleri

Katalogta verilen tüm redüktörlerin motorları S1 çalışma türüne uygun verilmektedir. Diğer çalışma türleri aşağıdaki tabloda gösterilmiştir.

#### b-Modes of Operation

All motors of the catalogue have been laid out for duty S1 (continuous operation). Other duty types are given on the following table.

#### b-Betriebsarten

Die im Katalog angeführten Motoren sind für Betriebsart S1 (Dauerbetrieb) ausgelegt. Andere Betriebsarten sind unten angegeben.

Çalışma Türü Operation Betriebsarten	Açıklama Explanation Erläuterung	Yük Grafiği Load Graphic Lastverläufe
S1	<b>Sabit yükte sürekli çalışma</b> Continuous operation under constant load Dauerbetrieb mit konstanter Belastung	
S2	<b>Sabit yükte kısa süreli çalışma</b> Short-time duty under constant load Kurzbetrieb mit konstanter Belastung	
S3	<b>Yolvermede sıcaklık artımı olmadan periyodik çalışma</b> Periodic duty without influence of start-up on temperature Aussetzbetrieb ohne Einfluß des Anlaufens auf die Temperatur	
S4	<b>Yolvermede sıcaklık artımı olan periyodik çalışma</b> Periodic duty with influence of start up on temperature Aussetzbetrieb mit Einfluß des Anlaufens auf die Temperatur	
S5	<b>Yolvermede ve frenlemede sıcaklık artımlı periyodik çalışma</b> Periodic duty with influence of startup and braking on temp. Aussetzbetrieb mit Einfluß des Anlaufens / Bremsung auf die Temp.	
S6	<b>Sürekli orta darbeleri çalışma</b> Continuous operation with intermittent loading Durchlaufbetrieb mit Aussetzungsbelastung	
S7	<b>Elektriksel frenlemeli sürekli orta darbeleri çalışma</b> Continuous operation with intermittent loading and braking Ununterbrochener Betrieb mit Anlauf und Bremsung	
S8	<b>Devir ve yük değişimli sürekli çalışma</b> Continuous operation duty type with related load-speed changes Ununterbrochener periodischer Betrieb mit Drehzahländerung	



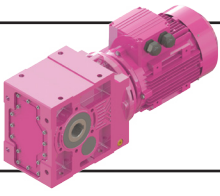

# Genel Bilgiler

## General Information

### Einführung



#### c- Koruma Sınıfı:

Yılmaz Redüktörde standart olarak IP54 (IEC 34-5) koruma sınıfı motorlar kullanılmaktadır. Diğer koruma sınıfları istendiğinde firmamıza danışınız.

#### d- İzolasyon Sınıfı:

Yılmaz Redüktörde kullanılan standart izolasyon sınıfı F (IEC 317-8) dir. İstek üzerine H sınıfı yapılabilmektedir.

#### e- Verim Sınıfları:

Üç fazlı az gerilim asenkron motorların verim sınıfı ölçümü IEC 60034-2-1:2007 normu ile belirlenmiştir. Yeni IE verim sınıfı 0,75 kW'tan 375 kW'a kadar güç aralığında çalışan AC motorlar için geçerlidir. EFF verim sınıfından farklı olarak IE verim sınıfı 6 kutup sayılı motorlar içinde kullanılabilir. Aşağıda verim sınıfları sıralanmıştır. Bölgeler dışında verim sınıfı zorunlulukları ülkelere göre farklılık gösterebilir. Lütfen firmamıza danışınız. Başka ürünlere entegre olmuş ve bu nedenle motorun veriminin bağımsız belirlenmediği sistemlerde (redüktör pompa gibi) verim sınıflandırması geçerli değildir.

#### c- Protection Class:

Yılmaz Redüktör uses IP54 (IEC 34-5) protection class electric motors for standard products. If different kind of protection class is requested please contact us.

#### d- Insulation Class:

Yılmaz Redüktör uses F (IEC 317-8) insulation class electric motors for standard products. H insulation class is available upon request.

#### e- Efficiency Classes:

The method for measuring the efficiency of low voltage three-phase asynchronous motors was revised with the new IEC 60034-2-1:2007 standard. The new IE classes is valid for AC Motors in power range from 0,75 to 375 kW. Unlike the EFF classes IE classes can be used for 6-pole AC motors. Bellow is the table of efficiency classes. The instructions for efficiency classes can differ from country to country. Please contact with us for more information. For the motors, which are fully integrated into a product (for example gear, pump) so their energy efficiency can not be recognized independently, the requirements of efficiency are not valid in Europe.

#### c- Schutzarten:

Yılmaz Redüktör Getriebemotoren werden serienmäßig mit Schutzart IP54 (IEC34-5) ausgeführt. Für andere Schutzarten bitte rückfragen.

#### d- Isolationsklasse:

Yılmaz Redüktör Getriebemotoren werden serienmäßig in Wärmeklasse F (IEC317-8) ausgeführt. H Wärmeklasse ist möglich auf Kundenwunsch.

#### e- Energieeffizienzklassen:

Die Methode für Messung die Effizienz von drei phasigen gering Spannung Asynchronmotoren hat neu mit IEC 60034-2-1:2007 Norm festgestellt. Die neue IE-Klassen gelten für alle Drehstrommotoren im Leistungsbereich von 0,75 bis 375 kW. Anders als EFF-Klassen die IE-Klassen können auch für 6-polige Drehstrommotoren verwendet werden. Unten steht die Tabelle der Effizienzklassen. Die Richtlinien für Effizienzklassen können sich je nach dem Land unterscheiden. Bitte mit unserem Firma Kontakt aufnehmen. Für die Motoren, die vollständig in ein Produkt (zum Beispiel Getriebe, Pumpe) eingebaut sind und deren Energieeffizienz nicht unabhängig von diesem Produkt erfasst werden kann, gelten in Europa die Anforderungen der Effizienzklassen nicht.

Verim Sınıfları Efficiency Classes Energieeffizienzklassen			4 Kutuplu Motor Verim Değeri Hesabı Calculating Efficiency Values of Motors with 4 Poles Berechnung der Wirkungsgrade von Elektromotoren mit 4 Polen	
IE1	EFF 2	<b>Standart Verim</b> Standart Efficiency Standarte Energieeffizienz	A=0,5234 B=-5,0499 C=17,4180 D=74,3171	$\eta_{Mn} = A \times [\log_{10}(P_L)] + B \times [\log_{10}(P_L)]^2 + C \times \log_{10}(P_L) + D$ <p><math>P_L</math> :Anma Yüğü [kW] / Nominal Load [kW] / Nennlast [kW]</p> <p><math>\eta_{Mn}</math> :Nominal verim / Nominal Efficiency [kW] / Sollwirkungsgrad</p>
IE2	EFF 1	<b>Yüksek Verim</b> High Efficiency Hohe Energieeffizienz	A=0,0278 B=-1,9247 C=10,4395 D=80,9761	
IE3	-	<b>Premium Verim</b> Premium Efficiency Premium Energieeffizienz	A=0,0773 B=-1,8951 C=9,2984 D=83,7025	
IE4	-	<b>Süper Premium Verim</b> Super Premium Efficiency Super Premium Energieeffizienz	-	

4 Kutuplu Motor Verim Değerleri Efficiency Values of Motor with 4 poles Sollwirkungsgrad des Motors mit 4 Polen	Anma Yüğü [kW] Nominal Load [kW] Nennlast [kW]	Verim Sınıfı / Efficiency Class / Energieeffizienzklassen		
		IE1	IE2	IE3
	0,75	72,1 %	79,6 %	82,5 %
	1,5	77,2 %	82,8 %	85,3 %
	3	81,5 %	85,5 %	87,7 %
	7,5	86 %	88,7 %	90,4 %
	15	88,7 %	90,6 %	92,1 %
	22	89,9 %	91,6 %	93 %
	37	91,2 %	92,7 %	93,9 %
	45	91,7 %	93,1 %	94,2 %
	75	92,7 %	94 %	95 %
	90	93 %	94,2 %	95,2 %
	330	94 %	95,1 %	96 %

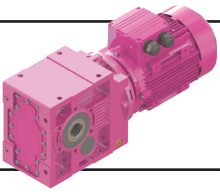

# Genel Bilgiler General Information Einführung



## f- AC Frekans Invertörler

Doğru Akımı (DC), alternatif akıma (AC) çeviren elektronik çeviricilere invertör denilmektedir. AC motorlar için elektronik hız kontrol cihazları genellikle AC giriş akımını doğrultucu diyotlarla DC akıma çevirir ve daha sonra çevirici diyotlar vasıtasıyla bu akımı tekrar AC akıma çevirir. Doğrultucu diyotlar ile çevirici diyotlar arasındaki bağlantı DC-bağ olarak tanımlanmaktadır. DC kontrol cihazının (genellikle invertör olarak isimlendirilir) elektriksel blok şeması aşağıda verilmiştir.

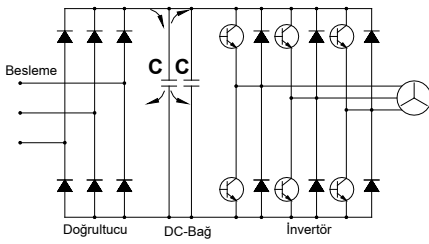

Tam dalga doğrultucuları besleyen üç faz besleme akımı DC-bağ kapasitörlerine iletilir. Kapasitörler voltajdaki dalgalanmaları azaltır ve kısa süreli ağıdaki akım kesintilerinde enerji sağlar. Kapasitörlerdeki voltaj kontrolsüzdür ve gelen AC akımın pik akım değerlerine bağlıdır. DC akım tekrar AC akıma, Puls genişliği modülasyonu (PWM) kullanılarak çevrilir. İstenen dalga formu, sabit bir frekansta (Puls frekansında), çıkış transistörlerinin (İzole edilmiş geçit Bipolar transistörleri; IGBT'ler) açılıp kapatılması ile oluşturulur. IGBT'lerin açma kapama zamanlarının değişimi ile istenen akım oluşturulabilir. Çıkış voltajı bir seri kare dalga pulslardır ve motor sargılarının indüktansı ile sinusoidal bir motor akımı oluşur. Puls genişliği modülasyonu aşağıda gösterilmiştir.

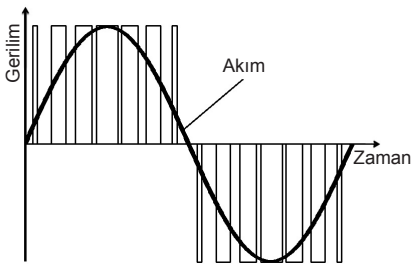

## f- AC Frequency Inverters

An electronic converter is a device which converts Direct Current (DC) to Alternating Current (AC) is known as an inverter. Electronic speed controllers for AC motors usually convert the AC supply to DC using a rectifier, and then convert it back to a variable frequency, variable voltage AC supply using an inverter bridge. The connection between the rectifier and inverter is called the DC link. The block diagram of a speed controller (often called an inverter) is shown below.

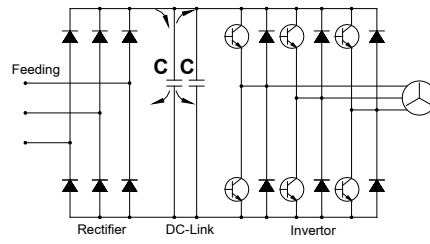

The three phase supply is fed into a full wave rectifier which supplies the DC link capacitors. The capacitors reduce the voltage ripple (especially on single supplies) and supply energy for short mains breaks. The voltage on the capacitors is uncontrolled and depends on the peak AC supply voltage. The DC voltage is converted back to AC using Pulse Width Modulation (PWM). The desired waveform is built up by switching the output transistors (Insulated Gate Bipolar Transistors; IGBTs) on and off at a fixed frequency (the switching frequency). By varying the on and off time of the IGBTs the desired current can be generated. The output voltage is still a series of square wave pulses and the inductance of the motor windings results in a sinusoidal motor current. Pulse Width Modulation is shown in the figure below.

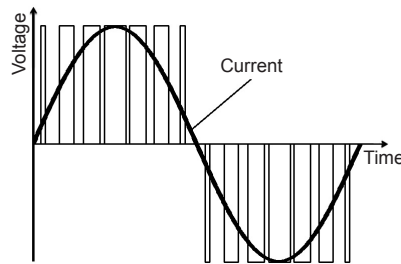

## f- AC Frequenz Umrichter

Ein elektronischer Wandler, der den Gleichstrom (DC) in Wechselstrom (AC) umwandelt, wird als Umrichter bezeichnet. Ein Frequenzumrichter benutzt einen ungesteuerten Eingangsgleichrichter, um die Netzspannung in Gleichspannung umzuwandeln. Diese wird dann in den Zwischenkreiskondensatoren gespeichert. An diesem Gleichspannungszwischenkreis ist ein Wechselrichter angeschlossen. Dieser Wechselrichter erzeugt am Ausgang eine variable Frequenz und eine variable Spannung. Der Anschluss zwischen dem Gleichrichter und dem Wechselrichter nennt man Gleichstromverbindung. Das Blockschaltbild von diesem System wurde unten dargestellt:

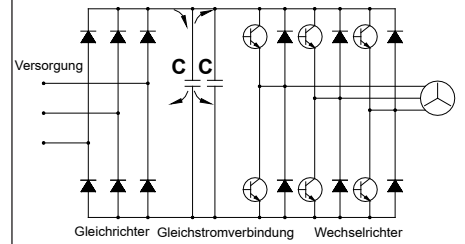

Auch bei dreiphasiger Versorgung wird die gleichrichtete Netzspannung den Zwischenkreiskondensatoren zugeführt. Die Kondensatoren reduzieren die Oberwelligkeit der Spannung (was besonders bei einphasiger Versorgung entscheidend ist) und liefern Energie, die kurze Unterbrechungen der Netzstromversorgung ermöglicht. Die Spannung der Kondensatoren ist vom Spitzenwert der Wechselspannung abhängig. Die Gleichspannung wird im Wechselrichter durch Pulsweitenmodulation (PWM) in Wechselspannung umgewandelt. Die gewünschte Wellenform wird durch Ein- und Ausschalten der Ausgangstransistoren (IGBT's Isolierte Gate Bipolar Transistoren) mit einer festen Frequenz (der Pulsfrequenz) erzeugt. Der gewünschte Strom kann durch die Variation der Ein- und Ausschaltzeit der Ausgangstransistoren generiert werden. Die Ausgangsspannung ist dadurch eine Reihe von Spannungsimpulsen, die in Verbindung mit der Induktivität der Motorspulen zu einem sinusförmigen Motorstrom führt. Die Pulsweitenmodulation wird wie folgt dargestellt

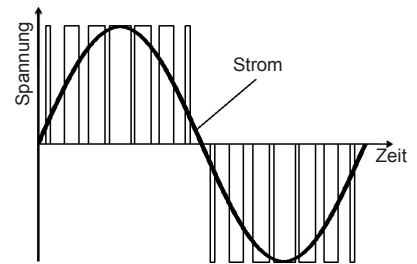

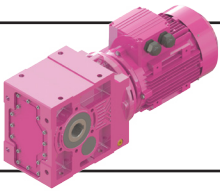

# Genel Bilgiler

## General Information

### Einführung



#### DC MOTORLAR

##### a- Genel Özellikler

DC motorlar, elektronik parçalardaki gelişmeler nedeni ile yeni uygulama alanları bulmuştur. Daha önce çok pahalı olan ve ekonomik olmayan kontrol sistemlerinin yerini ucuz ve kompakt güç kontrol üniteleri almıştır. Yol vermenin kontrol altına alınabildiği, tork ve akım izlenebilirliği, aşırı yüklenmeye karşı elektronik koruma sağlanabilmesi ve daha birçok pahalı olmayan uygulamalar DC motorlarını cazip kılmaya başlamıştır.

##### b- DC Motorların Çalışma İlkeleri

DC motorlar için DC çıkış veren bir doğrultucuya ihtiyaç vardır. Motor armatür sargıları, alan sargıları, komutasyon sargıları ve kompanse sargılar olmak üzere rotorda ve statorda bulunan sargılardan oluşur. Rotora voltaj ve akım karbon fırçalar ve komutator sargılarla ulaştırılır. Bu karbon fırçalar aşındığından DC motorlar belirli periyotlarla bakıma alınmalıdır. İyi kontrol edilebilir özelliklerinden dolayı DC motorlar otomasyon teknolojisinde sıkça kullanılmaktadır.

##### c- DC Motor Çeşitleri

Temel olarak Şönt (Shunt) ve seri sargılı DC motorlar bulunmaktadır. Bu sargıların çeşidine göre moment eğrisi değişmektedir.

##### d- DC Motorlarda Hız Kontrolü

Bu motorlarda devir değişimi DC voltajın değiştirilmesi ile yapılır. Şönt sarımlı DC motorların sıfır yük ile maksimum yük arasındaki davranışı AC motorlara benzer. Devir artan yükte beraber düşer. Bu devir farkı ufak güçlü motorlarda büyük, büyük güçlü motorlarda ise ufaktır. Fakat bu hız farkı DC doğrultucu cihazda armatür voltajı ( $I \times R$ ) ile oynanarak kompanse edilebilir. Hassas hız kontrol gereksinimi olduğunda, tako jeneratörler kullanılabilir. DC motorların gücü aşağıdaki formülden hesaplanır;

$$P_g = U \times I = \frac{P_c}{\eta}$$

$P_g$  : Giriş gücü W  
 $P_c$  : Çıkış gücü W  
 $U$  : Armatür gerilimi V  
 $I$  : Armatür akımı A  
 $\eta$  : Motor verimi

#### DC MOTORS

##### a- General Specifications of DC Motors

*DC drive systems have found new possible applications with the development of the electronic components sector. What was previously extremely expensive and in some cases not economically feasible is nowadays realized by miniaturised power converter technology. Additional functions such as guided startup after a predetermined time, torque and current monitoring with electronic protection against overloading, and many inexpensive special applications have made DC drive systems more attractive.*

##### b- Operating principles of the DC Motors

*The DC motor requires, a converter with DC output. The motor includes windings, such as armature, field, commutation and compensation windings, which are arranged in the stator as well as on rotor. Voltage and current are supplied to the rotor via the carbon brushes and the commutator. The carbon brushes are wearing parts therefore a DC motor requires maintenance at service intervals. While its good control properties, the DC motor is an essential item in automation technology.*

##### c- Types of DC Motors

*Depending on the wiring of the exciting winding or field winding, two basically different variants are regards torque speed characteristics may be distinguished.*

##### d- Speed Control of DC motors

*In DC motors the speed is adjusted by altering the DC voltage. DC shunt wounded motors behave similar to three phase induction motors between no load operation and maximum load. The speed drops with increasing loading of the motor. This difference is greater in small motors and smaller in larger motors. The speed difference can be compensated in the DC converter device by adjusting ( $I \times R$ ). If great control accuracy is required, a speed control with measurement of the actual values by a tachogenerator can be used. The power of DC motor;*

$$P_g = U \times I = \frac{P_c}{\eta}$$

$P_g$  : Input Power W  
 $P_c$  : Output Power W  
 $U$  : Armature Voltage V  
 $I$  : Armature Current A  
 $\eta$  : Motor efficiency

#### DC MOTOREN

##### a- Eigenschaften von DC Motoren

Mit den Entwicklungen bei elektronischen Komponenten haben DC Motoren neue Anwendungsbereiche gefunden. Regelungssysteme, die früher sehr teuer und im manchen Anwendungsfällen ungünstig waren, sind jetzt kompakt und günstig. Bei den DC Motoren ist kontrolliertes Anlauf, Moment- und Stromüberwachung mit Überlastschutz möglich. Es gibt viele günstige Sonderanwendungen für diese Motoren. Wegen oben genannten Eigenschaften werden die DC Motoren immer mehr bei unterschiedlichen Anwendungen benutzt.

##### b- Funktionsprinzip der DC Motoren

Bei DC Motoren ist eine Kommutatorwicklung im Rotor angeordnet, während der magnetische Fluss vom Stator erzeugt wird. Dies kann wiederum mittels einer Erregerwicklung oder durch Permanentmagnete geschehen. Wie bei der Synchronmaschine wird durch das Erregerfeld in der Ankerwicklung eine Wechsellspannung, die bei der Gleichstrommaschine jedoch durch den mechanischen Kommutator und die darauf schleifenden Bürsten in eine Gleichspannung umgeformt wird, induziert.

##### c- Arten von DC Motoren

Es gibt zwei verschiedene Wicklungen, nämlich Shunt- und Serial-Wicklung. Das Drehmoment-Drehzahl-Verhältnis ist für beide Wicklungen unterschiedlich.

##### d- Drehzahl Kontrolle für DC Motoren

Drehzahl von DC Motoren kann man mit Steuerung der DC Spannung ändern. DC Motoren mit Shunt Wicklungen ist ähnlich zu drei phasen AC Motoren zwischen maximalen Last und ohne Last. Drehzahl wird mit der Last reduziert. Mit kleineren Motoren wird dieser Differenz höher mit größeren Motoren kleiner. Der Drehzahlunterschied kann geregelt werden mit ( $I \times R$ ) Veränderung. Wenn eine genaue Kontrolle gebraucht, soll ein Tachogenerator benutzt werden. Leistung des DC Motors;

$$P_g = U \times I = \frac{P_c}{\eta}$$

$P_g$  : Eingangsleistung W  
 $P_c$  : Ausgangsleistung W  
 $U$  : Ankerspannung V  
 $I$  : Ankerstrom A  
 $\eta$  : Wirkungsgrad des Motors

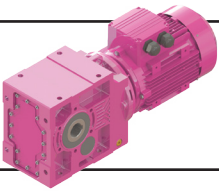

# Genel Bilgiler

## General Information

### Einführung



#### Elektromanyetik Frenler

Bu tip frenlerin iki sürtünme yüzeyi vardır. Fren torku, voltaj uygulanmadığı zaman yayların kuvveti ile oluşturulur. Fren elektromanyetik alanın oluşumu ile serbest kalır. Bobinin beslenmesi ile mıknatıslanan balata baskı pulu, elektromıknatısa doğru çekilir. Bu hareket yayları baskı altına alır ve rotor mili üzerine takılan çoklu kama üzerinde aksiyal yönde serbest hareket edebilen balata serbest kalır. Akım kesildiğinde yayların baskısıyla, balata baskı pulu fren balatasına doğru itilir ve bu hareket rotoru frenler.

#### Fren Çeşitleri

##### a) Soğutmasız tip frenler

Motor fanı çıkarılıp motor kapağı arkasına akupile edilerek kullanılan frenler; genellikle sıkça açılıp kapanmayan ve kısa zaman aralıklarında çalışan sistemlerde tercih edilir.

##### b) Soğutmalı tip frenler

Motor fanı çıkarılıp motor kapağı arkasına akupile edilen ve motorun mili uzatılarak fren ve motorun arkasına alınan fan sayesinde daimi bir hava sirkülasyonu sağlanarak kullanılan frenlerdir. Genellikle uzun süreli çalışan ve kapalı mekanlarda kullanılan sistemlerde tercih edilir.

##### c) Manuel kol sistemli frenler

Çalışma sistemi olarak her iki fren tipinde de kullanılabilir (soğutmalı veya soğutmasız). Özel durumlarda (elektrik kesilmesi; mekanik problemler) üzerinde bulunan bir kol vasıtası ile sistemi yay baskısından kurtararak serbest kalmasını sağlayan frenlerdir. Genellikle manuel olarak sistemin açılması gereken yerlerde (otomatik giriş kapıları, dış cepe boyama asansörleri v.b.) tercih edilir.

#### Fren çalışma voltajları

Elektromanyetik frenler 230V AC veya 400V AC beslemeli olarak sipariş edilebilir. Frenler DC fren olmaları nedeni ile besleme ile fren bobini arasında fren tipine bağlı olarak, yarım dalga, tam dalga doğrultucular veya trafolar kullanılır. Özel olarak belirtilmedikçe 230V beslemeli ve yarım dalga doğrultuculu frenler kullanılmaktadır. Özel durumlar için YILMAZ Redüktöre danışınız.

##### a) 230V AC ile beslenen frenler

Motor klemens kutusundan alınan 230V'luk AC besleme fren tipine bağlı olarak yarım dalga veya tam dalga doğrultucu ile fren bobininin voltajına düşürülür. Fren bobin DC voltajı etiketi üzerinde belirtilmiştir.

##### b) 400V AC ile beslenen DC frenler

Motor klemens kutusundan alınan 400V'luk AC besleme, yarım dalga doğrultucu ile fren bobininin voltajına düşürülür. Fren bobininin DC voltajı etiket üzerinde belirtilmiştir.

##### c) 24V DC Frenler

Kullanılan fren momentinin büyüklüğüne göre besleme transformatörü seçilir. Şebekeden veya motorun klemens kutusundan alınan besleme voltajı transformatörde 29 V'a çevrilen gerilim tam dalga doğrultuculardan geçerek 24V DC'ye çevrilir ve fren bobini beslenir.

#### Electromagnetic Brakes

*This type of brakes has two friction surfaces. Brake torque is generated by springs when no voltage is applied. The brake is electromagnetically released. On exciting the electromagnet means of the current, the armature plate is pulled towards the electromagnet itself, thrust loading the pressure spring and enabling the friction disc which is axially movable on the key, to turn freely. When current fails, the pressured springs drive the armature plate towards the disc, thus braking the motor shaft.*

#### Brake Types

##### a) Brakes without cooling

*This type of brakes are assembled on the back cover of the electric motor. There is no fan on the backside. This brake type is mostly preferred in short working times and short working cycles.*

##### b) Fan cooled brakes

*This type of brakes are assembled on the back cover of electric motor by removing the electric motor fan. A fan is coupled to the backside of the brake by extending the rotor shaft of the electric motor. Fan cooled brakes are preferred in long working times and closed places without airflow.*

##### c) Brakes with hand release

*This brakes can be released by help of an arm. It can be applied to both of the above mentioned brakes and used in special cases (fail of electric current, mechanical problems etc.) These brakes are mostly preferred if operation (re-lasing) without a current is needed (automatic controlled doors, gates, building wall painting elevators etc.).*

#### Working Voltages

*Electromagnetic brakes can be ordered with 230V AC or 400V AC supply voltage. The coil of brakes needs DC voltage and therefore depending on brake type a half wave, a full wave rectifier or transformer should be used between supply and coil voltage. As standard the brakes will be delivered with 230V supply voltage and half wave rectifier, if there is no special request. For special cases please contact YILMAZ Redüktor.*

##### a) Brakes with 230V supply voltage

*230V AC supply voltage from the motor terminal box will be reduced to the coil voltage depending on the brake type with half-wave or full-wave rectifier. DC brake coil voltage is indicated on the label.*

##### b) Brakes with 400V supply voltage

*400V AC supply voltage from the motor terminal box will be reduced to the coil voltage with half-wave rectifier. DC brake coil voltage indicated on the label.*

##### c) 24V DC Brakes

*The transformer's size is selected according to value of brake torque. The current is taken from the electric motor terminal box or from the electric panel and is transformed to 29V DC current. This current is transferred to 24V DC current with full-wave rectifier and supplies brake coil.*

#### Elektromagnetische Bremsen

Die Bremse hat zwei Reibflächen und arbeitet nach dem Ruhestromprinzip. Im stromlosen Zustand wird das Bremsmoment durch den Druck der Feder erzeugt, während die Bremse beim Betrieb elektromagnetisch losgelassen wird. Durch die Erregung der Elektromagneten wird die Ankerscheibe zu den Elektromagneten gezogen und die Feder zusammgedrückt. Dadurch kann sich die Bremscheibe, die axial beweglich auf dem Mitnehmer angeordnet ist, frei drehen. Wird der Strom unterbrochen, drücken die Feder die Ankerscheibe gegen die Bremscheibe und halten die Motorwelle an.

#### Bremsearten:

##### a) Bremsen ohne Kühlung

Diese Bremsen sind für Kurzlaufzeiten geeignet. Die Lüfterhaube und Lüfter des Motors ist ausgebaut und die Bremse ist an dem Ende der Motorwelle befestigt.

##### b) Bremsen mit Kühlung

Diese Bremsen sind für lange Laufzeiten und kleine, abgedeckte Räume geeignet. Durch die Verlängerung der Motorwelle wurde Lüfter hinter dem Bremse und dem Motor verbunden. Somit wurde eine konstante Lüftung ermöglicht.

##### c) Bremsen mit Hebelarm

Diese Bremsenart kann mit oder ohne Kühlung verwendet werden. Diese Bremsen sind bei der speziellen Fälle, wie keine Spannung an der Leitung, mechanische Probleme usw., anwendbar. Die Bremse wird mit einem Hebelarm manuell betätigt. Diese Bremsen werden am meisten an den Stellen, wo die Lüftung ohne Spannung erfolgen soll, benutzt (automatische Türe, Wandaufzüge).

#### Betriebsspannungen

Elektromagnetische Bremsen können mit 230V AC oder 400V AC Versorgungsspannung bestellt werden. Die Wicklungen der Bremsen brauchen Gleichspannung und deswegen abhängig von Bremsenart zwischen Versorgungsspannung und Wicklungsspannung soll Halbwellen-, Vollweggleichrichter oder Transformator verwendet werden. Als Standard die Bremsen werden mit 230V Versorgungsspannung und Halbwellengleichrichter geliefert.

##### a) Bremsen mit 230V Versorgungsspannung

230V AC Versorgungsspannung von Klemmenkasten wird auf die Wicklungsspannung abhängig von der Bremsentyp mit Halbwellen-oder Vollweggleichrichter reduziert. Wicklungsspannung ist auf dem Etikett angegeben.

##### b) Bremsen mit 400V Versorgungsspannung

400V AC Versorgungsspannung von Klemmenkasten wird auf die Wicklungsspannung mit Halbwellengleichrichter reduziert. Wicklungsspannung ist auf dem Etikett angegeben.

##### c) 24 V DC Bremsen

Die Spannung wird von den Klemmkasten des Motors oder Elektrischrank entnommen. Diese Spannung wird zuerst mittels Transformator zu 24 V reduziert. Danach wird diese Spannung mit Hilfe von Gleichrichter zu Gleichstromspannung umgewandelt. Die Größe des Transformators ist abhängig von der Größe des Bremsmoments.

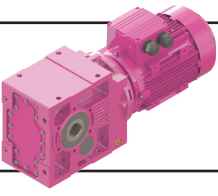

# Genel Bilgiler

## General Information

### Einführung



#### d) Şok ikazlı trafolar

Büyük güçteki ve momentteki frenlerin manyetik doyuma ulaşmaları uzun zaman alır. Şok ikazlı trafolar frenin yay baskısını yenmede gecikmesini engellemek için kullanılır ve zaman rölesi yardımı ile çok kısa bir süre normal besleme voltajının iki katı ile (48V DC) beslenip sistemin ani açılmasını sağlar. Bu sayede gecikmeli açılımda ortaya çıkacak sürtünmeyi engellemeye yarayan bir trafo şeklindedir.

#### Fren bağlantı şekli

##### a) Gecikmeli frenleme

Genellikle sistemin yavaş ve kaydırılarak durması gereken yerlerde tercih edilen bağlantı şeklidir. Vinç yürütme motorlarındaki sarsıntıyı önlemek için gecikmeli bağlantı şekli kullanılır. Frenler fabrika çıkışında gecikmeli bağlantıya uygun ayarlanır.

##### b) Ani frenleme

Genellikle sistemin enerjisi kesildiği anda ani olarak durdurulması gereken sistemlerde kullanılan bağlantı şeklidir. Vinç kaldırma sistemleri, asansör motorlarında kullanılan bağlantı şeklidir.

#### d) Shock voltage supply transformer

Brakes which consist of high power and torques take long time to get in electromagnetic field. Shock voltage supply transformers with time relay are aiming to overcome spring pressure delaying for brakes. Also this transformers provide to open system suddenly by feeding double(48V DC) voltage in a short time and preventing to frictional losses occurring in delayed opening.

#### Connection Types

##### a) Delayed Braking

Generally this type of connection uses in slow and sliding brake intended systems. Delayed connection type using to prevent shock loadings in crane driving systems. Brakes are setting up to delayed connection if any other types are not specified by customer

##### b) Sudden Braking

This type of connections are mostly used in systems when short braking times are needed. The braking torque will be produced as soon as the current fails. These brakes are mostly used in hoisting of lifting units and elevators.

#### d) Trafos mit Schock-Spannung

Diese Transformatoren werden bei großen Bremsen mit hohen Momenten verwendet. Da die große Bremsen eine lange Zeit braucht, um die erforderliche magnetische Feld zu erzeugen, wird an der Bremse kurz 48V Gleichstromspannung angelegt, um die Zeit zur Bildung von magnetischem Feld zu kürzen. Dies ermöglicht kürzere Reibungszeiten beim Start.

#### Schaltungsarten:

##### a) Verspätetes Bremsen

Diese Schaltung wird benutzt, wenn ein langsames und gleitendes Bremsen erforderlich ist. Am meisten wird es bei Fahrtriebemotoren von Aufzügen verwendet. Wenn keine Angabe bei der Bestellung gegeben wird, werden die Bremsen mit verspäteter Schaltung geliefert.

##### b) Schnelles Bremsen:

Allgemein verwendet man diese Schaltung bei Bedarf an plötzlichen Bremsen in dem Augenblick, in dem das System keine Energie mehr erhält. Diese Schaltungsart wird meist bei Kräne und Motoren von Aufzüge verwendet.

**Gecikmeli Frenleme / Delayed Running Brake / Verspätete Bremsung**  
(230 V)

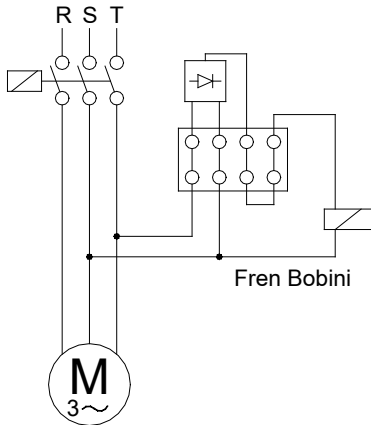

**Ani Frenleme / Sudden Brake / Plötzliche Bremsung**  
(230 V)

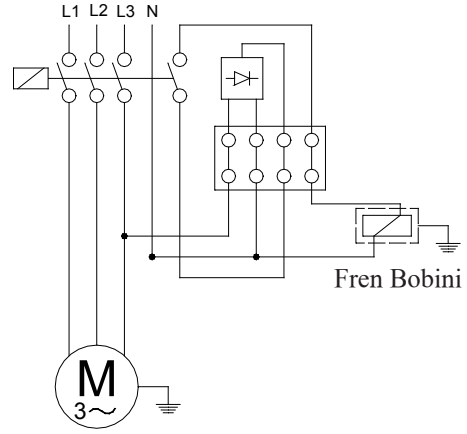

**Gecikmeli Frenleme / Delayed Running Brake / Verspätete Bremsung**  
(24 V)

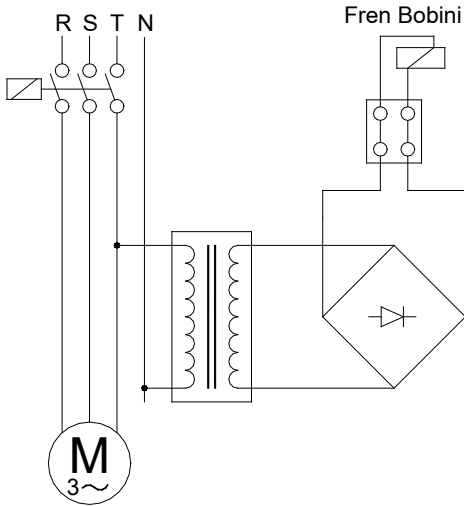

**Ani Frenleme / Sudden Brake / Plötzliche Bremsung**  
(24 V)

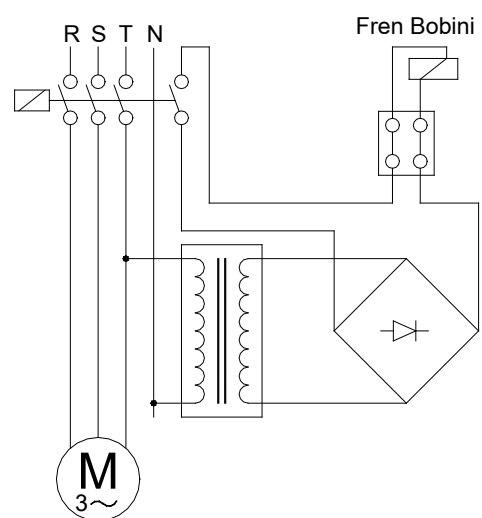

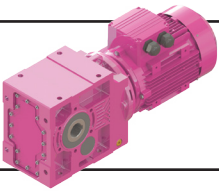

# Genel Bilgiler

## General Information

### Einführung



#### Fren Seçimi:

Doğru bir fren seçimi için aşağıdaki parametreler bilinmelidir.

- $I_{tot}$  [kg.m<sup>2</sup>] : Motor miline indirgenmiş toplam atalet momenti
- $n_0$  [d/dak] : Maksimum motor devir sayısı
- $t_f$  [s] : İstenilen en uzun frenleme zamanı
- $c_t$  : Anahtarın devreye girme zamanı katsayısı (ortalama 0,995).
- $M_L$  [Nm] : Sistemin statik tork ihtiyacı.
- $C_s$  : Emniyet katsayısı ( $C_s \geq 2$  olmalı)

Gerekli fren momenti aşağıdaki şekilde hesaplanır:

a)  $M_L$  Statik yük torku, motor dönüş yönünde (motorun dönüşüne yardımcı olarak, yükün indirilmesi veya hızlandırıcı sabit yük momenti hali):

$$M_{fc} = \frac{(2\pi \times n_0 \div 60) \times I_{tot}}{t_f \times c_t} + M_L$$

b)  $M_L$  Statik yük torku, motor aksi dönüş yönünde (motorun dönüşüne engel olarak, yükün yukarı kaldırılması veya frenleyici sabit yük/direnç momenti hali):

$$M_{fc} = \frac{(2\pi \times n_0 \div 60) \times I_{tot}}{t_f \times c_t} - M_L$$

Yukarıda bulunan sonuç  $C_s$  katsayısı ile çarpılarak ( $C_s \geq 2$ ), fren momenti seçilir;

$$M_f = M_{fc} \times C_s$$

#### Yaklaşım Yolu ile Fren Seçimi:

Eğer yalnızca motorun gücü ve en yüksek devri biliniyor ise :

W [Watt]: Motorun nominal gücü

$$M_f = \frac{W}{\left(\frac{2\pi \times n_0}{60}\right)} \times C_s \quad (C_s \geq 2)$$

#### Brake Selection:

To select a brake correctly the following data are necessary;

- $I_{tot}$  [kg . m<sup>2</sup>] : The total inertia of rotating parts reduced at the motor shaft
- $n_0$  [rpm] : Maximum motor speed.
- $t_f$  [s] : The maximum admitted time of the braking.
- $c_t$  : Coefficient of switch on time (average 0,995).
- $M_L$  [Nm] : Required static torque of system.
- $C_s$  : Safety coefficient ( $C_s \geq 2$ )

The necessary braking torque calculates below;

a) The static load torque  $M_L$ , same direction of motor rotation (Descent of a load or steady resisting torque which favours the rotation of the motor)

$$M_{fc} = \frac{(2\pi \times n_0 \div 60) \times I_{tot}}{t_f \times c_t} + M_L$$

b) The static load torque  $M_L$ , opposes the rotation of the motor (Lifting of a load or steady resisting torque which opposes the rotation of the motor)

$$M_{fc} = \frac{(2\pi \times n_0 \div 60) \times I_{tot}}{t_f \times c_t} - M_L$$

The necessary braking torque will result from the following equation using  $C_s$  ( $C_s \geq 2$ );

$$M_f = M_{fc} \times C_s$$

#### Approximated Brake Selection

Its only the motor power and its maximum speed are known:

W [Watt]: Motor Nominal Power

$$M_f = \frac{W}{\left(\frac{2\pi \times n_0}{60}\right)} \times C_s \quad (C_s \geq 2)$$

#### Bremswahl:

Um die richtige Bremse auszuwählen, braucht man unten aufgelistete Variablen;

- $I_{tot}$  [kg . m<sup>2</sup>] : Die Gesamtträgheit der rotierenden Teile (siehe Anwendungsbeispiele)
- $n_0$  [U/min] : Die höchste Drehzahl des Motors
- $t_f$  [s] : Die längste zulässige Bremszeit
- $c_t$  : Reduktionskoeffizient der Tätigkeitszeit (gemittelt 0,995).
- $M_L$  [Nm] : Vom system benötigtes, statisches Drehmoment.
- $C_s$  : Sicherheitskoeffizient ( $C_s \geq 2$ )

Die benötigte Bremskraft wird wie folgt berechnet:

a) konstantes Belastungsmoment  $M_L$ , das die Motordrehung fördert (konstante Erhöhung der Motorgeschwindigkeit oder Herunterlassen der Last)

$$M_{fc} = \frac{(2\pi \times n_0 \div 60) \times I_{tot}}{t_f \times c_t} + M_L$$

b) konstantes Belastungsmoment  $M_L$ , das sich entgegen der Motordrehung widersetzt (konstante Verminderung der Motorgeschwindigkeit oder Aufheben der Last)

$$M_{fc} = \frac{(2\pi \times n_0 \div 60) \times I_{tot}}{t_f \times c_t} - M_L$$

Wenn die Bremskraft mit dem Sicherheitskoeffizient  $C_s$  ( $C_s \geq 2$ ) multipliziert wird, erhält man die erforderliche Bremskraft;

$$M_f = M_{fc} \times C_s$$

#### Abschätzung zur Bremswahl

Wenn man nur die Motorleistung und die höchste Drehzahl kennt, kann die Bremskraft mit der folgenden Formel annähernd berechnet werden:  
W [Watt] : Nennleistung des Motors

$$M_f = \frac{W}{\left(\frac{2\pi \times n_0}{60}\right)} \times C_s \quad (C_s \geq 2)$$

#### Standart Frenler / Standard Brakes / Standart Bremsen

<b>Fren statik momenti [Nm]</b> Brake Static Torque [Nm] Statische Bremskraft [Nm]	4,5	8	12	16	35	60	80	150	200
<b>Fren Dinamik Momenti [Nm]</b> Brake Dynamic Torque [Nm] Dynamische Bremskraft [Nm]	3,6	6,4	9,6	12,8	28	48	64	120	160
<b>Maksimum Motor Hızı [d/dak]</b> Maximum Motor Speed [rpm] Maximale Motordrehzahl [U/min]	3000	3000	3000	3000	3000	3000	3000	1500	1500
<b>Giriş Gücü [W]</b> Input Power [W] Antriebsleistung [W]	15	20	25	30	45	50	55	60	65

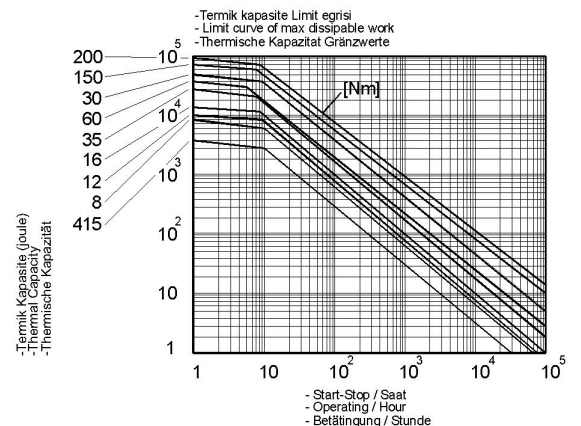

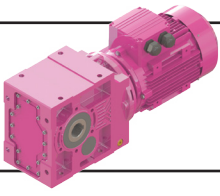

# Genel Bilgiler

## General Information

### Einführung



#### Frenin Termik Kapasitesi

Yukarıdaki seçime ek olarak frenin termik kapasitesinin kontrol edilmesi gerekir. L (joule) olarak gerekli soğutma işi aşağıdaki formüller ile hesaplanır ve "Termik kapasite limit eğrisi" kullanılarak eğrinin altında kalıp kalmadığı kontrol edilir.

a)  $M_L$  Statik yük torku motor dönüş yönünde (motorun dönüşüne yardımcı olarak, yükün indirilmesi hali)

$$L = \frac{I_{tot} \times (2 \pi \times n_0 \div 60)^2}{2} \times \left( \frac{M_f}{M_f - M_L} \right)$$

b)  $M_L$  Statik yük torku motor aksi dönüş yönünde (motorun dönüşüne engel olarak, yükün kaldırılması hali):

$$L = \frac{I_{tot} \times (2 \pi \times n_0 \div 60)^2}{2} \times \frac{M_f}{M_f + M_L}$$

c)  $M_L$  Statik yük torku sabit, motor yönünde veya aksi yönde (kaldırma ve indirme harici hızlandırıcı veya frenleyici sabit bir yük momenti hali).

$$L = \frac{I_{tot} \times (2 \pi \times n_0 \div 60)^2}{2}$$

#### Fren Hava Boşluğunun Ayarı:

Frenden sürekli aynı performansın alınabilmesi için, fren balatasının aşınmasına bağlı olarak, fren hava boşluğu belirli zaman aralıklarında yeniden ayarlanmalıdır. Fren hava boşluğu ayar zaman aralığı ve ayarın yapılması için firmamıza danışınız.

#### Fren Seçim Örneği:

İstenilen en uzun frenleme zamanı: 0,5 sn.

Motor devri: 1400 d/dak

Motoru indirgenmiş toplam atalet momenti:

0,08 kgm<sup>2</sup>

Gerekli çalışma momenti: 50 Nm

Yük Durumu: Yük motor dönüş yönü ile aynı (Vinçten yük indirilmesi: Saatte dur-kalk sayısı:30)

$$M_{fc} = \frac{(2 \pi \times 1400 \div 60)}{0,5 \times 0,995} + 50 = 73,6 \text{ Nm}$$

$$M_f = 73,6 \times 2 = 147,2 \text{ Nm}$$

Standart frenler tablosundan 150 Nm lik fren seçilebilir.

Gerekli termik kapasite;

$$L = \frac{0,08 \times (2 \pi \times 1400 \div 60)^2}{2} \times \left( \frac{147,2}{147,2 - 50} \right)$$

=1302,0 < 18000 Joule (150 Nm eğrisinden)  
150 Nm lik fren uygun görülüyor.

#### The Thermal Capacity of Brake

The thermal capacity of the brake must also be checked after the above mentioned calculations. The heat dissipation energy L (joule) can be calculated from the following equation and must be checked if the result is under the limit curve shown on "Limit curve of may dissipable work".

a) The static load torque  $M_L$ , favours the rotation of the motor (Descent of a load which favours the rotation of the motor)

$$L = \frac{I_{tot} \times (2 \pi \times n_0 \div 60)^2}{2} \times \left( \frac{M_f}{M_f - M_L} \right)$$

b) The static load torque  $M_L$ , opposes the rotation of the motor (Lifting of a load which opposes the rotation of the motor)

$$L = \frac{I_{tot} \times (2 \pi \times n_0 \div 60)^2}{2} \times \frac{M_f}{M_f + M_L}$$

c) The static load torque  $M_L$ , is constant and opposes or favours the rotation of the motor (except lifting of a load)

$$L = \frac{I_{tot} \times (2 \pi \times n_0 \div 60)^2}{2}$$

#### Adjustment of the air-gap:

In order to obtain the same performance from the brake during its lifetime, the air-gap of the brake must be re-adjusted after a limited time of operation. For the air-gap and the time interval of the adjustment please contact us.

#### Selection Example:

The maximum admitted time for braking 0,5 s

Motor speed: 1400 rpm

Total inertia reduced at motor shaft: 0,08 kgm<sup>2</sup>

Required operating torque: 50 Nm

Nature of load: Load direction is same as motor direction (Unloading process: Start-stop time per hour :30)

$$M_{fc} = \frac{(2 \pi \times 1400 \div 60)}{0,5 \times 0,995} + 50 = 73,6 \text{ Nm}$$

$$M_f = 73,6 \times 2 = 147,2 \text{ Nm}$$

From the brake selection table a standard brake of 150 Nm is selected.

Necessary thermal capacity

$$L = \frac{0,08 \times (2 \pi \times 1400 \div 60)^2}{2} \times \left( \frac{147,2}{147,2 - 50} \right)$$

=1302,0 < 18000 Joule (from 150 Nm curve)  
The selected brake with 150 Nm is suitable.

#### Thermische Kapazität der Bremsen

Nach den oben genannten Berechnungen muss die Thermische Kapazität überprüft werden. Die Wärme, d.h. die gebrauchte Energie L, werden mit den folgenden Formeln berechnet. Die gerechnete Kapazitätswerte sollen unter dem Grenzkurve "Thermische Kapazität Grenzwerte" der gewählten Bremse liegen.

a) Konstantes Belastungsmoment  $M_L$ , das die Motordrehung fördert (Herunterlassen der Last)

$$L = \frac{I_{tot} \times (2 \pi \times n_0 \div 60)^2}{2} \times \left( \frac{M_f}{M_f - M_L} \right)$$

b) Konstantes Belastungsmoment  $M_L$ , das sich entgegen der Motordrehung widersetzt (Aufheben der Last)

$$L = \frac{I_{tot} \times (2 \pi \times n_0 \div 60)^2}{2} \times \frac{M_f}{M_f + M_L}$$

c) Konstantes Belastungsmoment  $M_L$ , das sich gegen der Motorbewegung widersetzt oder die Motorrotation fördert (Konstante Verminderung oder Erhöhung der Motorgeschwindigkeit, kein Herunterlassen oder Aufheben der Last)

$$L = \frac{I_{tot} \times (2 \pi \times n_0 \div 60)^2}{2}$$

#### Einstellung des Luftspaltes:

Um eine immer konstant bleibende Bremsfähigkeit zu erhalten, muss das Luftspalt nach einer bestimmten Arbeitszeit neu eingestellt werden. Für die Bestimmung des Luftspaltes und die Einstellzeiten bitten wir Sie um Rückfrage.

#### Beispiel für eine Auswahl:

Die höchste zulässige Bremszeit: 0,5 s

Motordrehzahl: 1400 U/min

Gesamträgheit der rotierenden Teile: 0,08 kgm<sup>2</sup>

Das auf das System wirkende Drehmoment: 50 Nm

Belastungsart: Drehmoment, das die Motorrotation fördert (Herunterlassen der Last) Betätigungen pro Stunde:30

$$M_{fc} = \frac{(2 \pi \times 1400 \div 60)}{0,5 \times 0,995} + 50 = 73,6 \text{ Nm}$$

$$M_f = 73,6 \times 2 = 147,2 \text{ Nm}$$

Eine Bremse von 150 Nm kann man auswählen.

Die thermische Kapazität;

$$L = \frac{0,08 \times (2 \pi \times 1400 \div 60)^2}{2} \times \left( \frac{147,2}{147,2 - 50} \right)$$

=1302,0 < 18000 Joule (von 150 Nm Kurve) Die ausgewählte 150 Nm Bremse ist ausreichend.





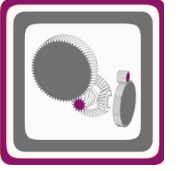
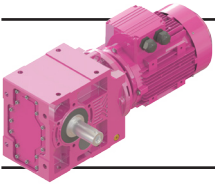

# Güç ve Devir Tabloları

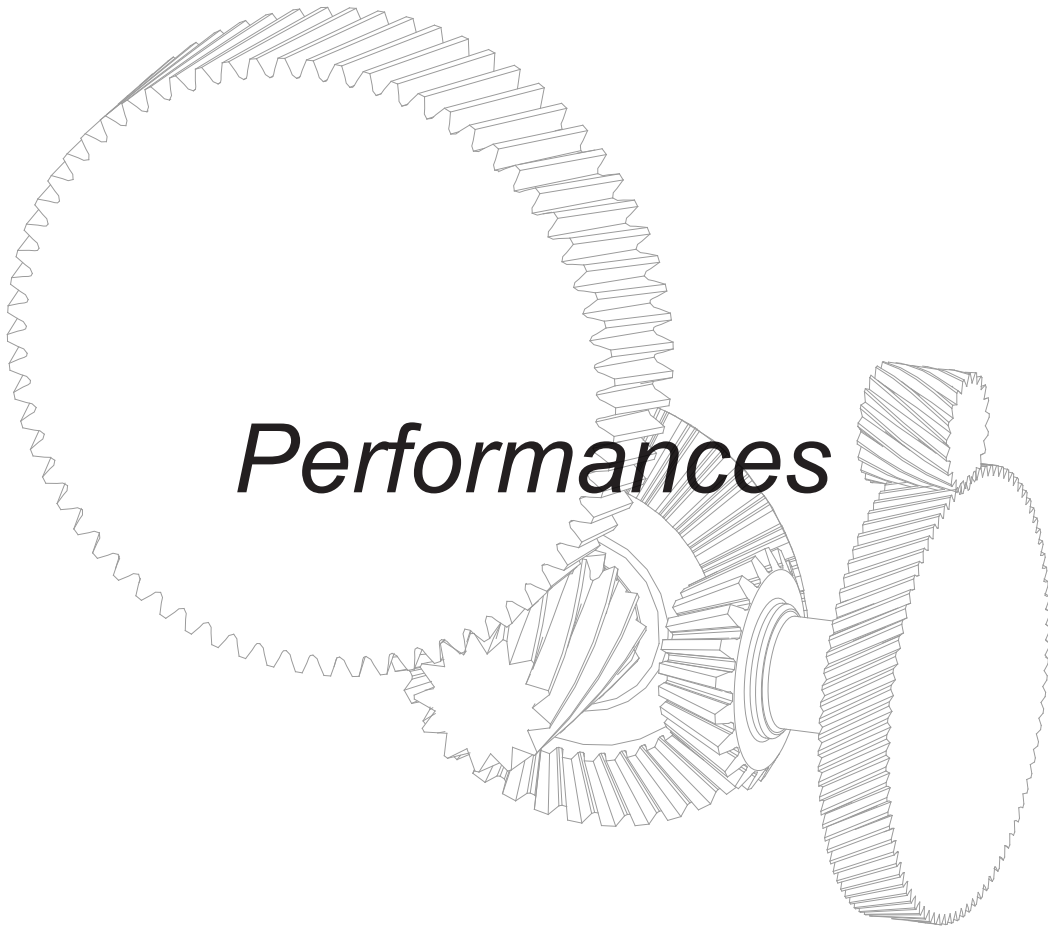

## Leistung und Drehzahlübersicht

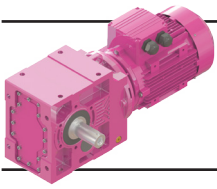

# K Serisi Motorlu Güç Devir Sayfaları

## K Series Geared Motors Performance Tables

### K Serien Getriebemotoren Leistung und Drehzahlübersicht

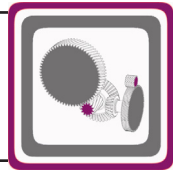

Güç	Çıkış Devri	Çıkış Momenti	Çevrim Oranı	Güv. Rad. Yük Çıkış	Servis Faktörü	Tipi	Anma Akımı	Ağırlık	Ölçü Sayfası	Motor Verim Snf.*
Power	Output Speeds	Output Torque	Ratio	Per.O. Loads (Output)	Service Factors	Type	Rated Current	Weight	Dim. Page	Motor Eff. Class
Leistung P <sub>g</sub> [kW] P <sub>g</sub> [HP]	Abtriebswelle Drehzahlen n <sub>2</sub> [r.p.m]	Abtriebswelle Drehmomente M <sub>2</sub> [Nm]	Übersetzung i	Zul.Querkräfte (Abtrieb) F <sub>qam</sub> [N]	Betriebsfaktor f <sub>s</sub>	Typ	Nennstrom [A]	Gewicht ~ [kg]	Maße Seite	Motor Effizienz-klasse
0,12 0,16	0,24	3625	5587,93	7240	0,7	KR576-G63/4a	0,41	156	138	IE1
	0,34	2626	4047,32	23398	1,0					
	0,38	2335	3597,31	26003	1,2					
	0,50	1792	2755,47	29938	1,5					
	0,59	1516	2328,84	31626	1,8					
	0,61	1484	2236,28	31807	1,8	KR575-G63/4a	0,41	151	138	IE1
	0,72	1255	1890,04	33033	2,2					
	1,0	909	1368,95	34685	3,0					
	0,48	1872	2873,07	13041	0,8	KR476-G63/4a	0,41	113	126	IE1
	0,51	1740	2663,91	14648	0,9					
	0,55	1629	2495,47	15826	1,0					
	0,63	1428	2183,54	17680	1,1					
	0,77	1174	1767,90	19651	1,3					
	0,92	981	1476,60	20883	1,6	KR475-G63/4a	0,41	109	126	IE1
	1,0	927	1395,04	21205	1,7					
1,1	811	1218,61	21859	1,9						
1,2	762	1142,99	22124	2,0						
1,4	648	971,77	22698	2,4						
1,5	602	901,03	22917	2,6						
1,6	564	844,06	23096	2,7						
0,80	1104	1699,70	7414	0,7	KR376-G63/4a	0,41	68	114	IE1	
0,91	977	1500,87	9855	0,8						
1,0	913	1401,91	10823	0,9						
1,2	773	1184,90	12605	1,1						
1,2	728	1094,97	13096	1,1	KR375-G63/4a	0,41	64	114	IE1	
1,4	644	968,01	13938	1,3						
1,7	542	814,20	14798	1,5						
2,0	461	692,22	15452	1,8						
2,3	395	593,11	15919	2,1						
2,5	358	536,75	16168	2,3						
2,9	317	473,96	16429	2,6						
3,1	296	442,71	16555	2,8						
1,5	574	881,79	11145	0,8						KR276-G63/4a
1,9	479	735,42	11863	0,9						
1,9	479	719,79	11862	0,9	KR275-G63/4a	0,41	29	102	IE1	
2,0	449	675,13	12064	1,0						
2,4	382	573,99	12488	1,2						
2,7	332	498,55	12772	1,4						
3,1	291	436,24	12990	1,5						
3,8	241	360,73	13234	1,9						
4,5	201	300,85	13412	2,2						
5,4	168	252,20	13557	2,7						
6,3	145	215,91	13646	3,1						
6,8	134	200,35	13683	3,4						
10	89	131,68	14145	4,0						
9,9	106	138,53	10316	2,6						KR203-G63/4a
11	92	119,62	9906	3,0						
11	99	129,27	6729	1,4	KR103-G63/4a	0,41	15	90	IE1	

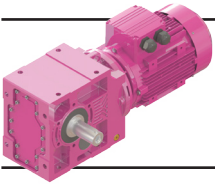

# K Serisi Motorlu Güç Devir Sayfaları

## K Series Geared Motors Performance Tables

### K Serien Getriebemotoren Leistung und Drehzahlübersicht

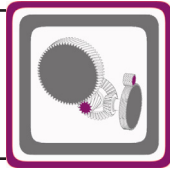

Güç	IE3 Çıkış Devri	IE3 Çıkış Momenti	Çevrim Oranı	IE3 Güv. Rad. Yük Çıkış	IE3 Servis Faktörü	Tipi	Anma Akımı	Ağırlık	Ölçü Sayfası	Motor Verim Snf.*
Power	Output Speeds	Output Torque	Ratio	Per.O. Loads (Output)	Service Factors	Type	Rated Current	Weight	Dim. Page	Motor Eff. Class
Leistung P <sub>g</sub> [kW] P <sub>g</sub> [HP]	Abtriebswelle Drehzahlen n <sub>2</sub> [r.p.m]	Abtriebswelle Drehmomente M <sub>2</sub> [Nm]	Übersetzung i	Zul.Querkräfte (Abtrieb) F <sub>qam</sub> [N]	Betriebsfaktor f <sub>s</sub>	Typ	Nennstrom [A]	Gewicht ~ [kg]	Maße Seite	Motor Effizienz- klasse
0,12 0,16	12	89	116,34	6883	1,6	KR103-G63/4a	0,41	15	90	IE1
	13	81	105,26	7001	1,7					
	15	68	88,87	7157	2,1					
	18	59	76,13	7256	2,4					
	20	52	67,22	7315	2,7					
	22	48	62,79	7342	2,9					
	11	93	120,91	3531	0,9	KR003-G63/4a	0,41	15	86	IE1
	14	75	98,44	4201	1,1					
	15	69	89,62	4408	1,2					
	17	62	80,66	4585	1,3					
	20	52	67,44	4810	1,5					
	24	44	57,16	4944	1,8					
	28	38	48,93	5038	2,1					
	30	35	45,41	5072	2,3					
	39	27	35,34	4972	2,9					
	46	23	29,95	4742	3,5					
	53	20	25,64	4532	4,0					
	57	18	23,79	4433	4,0					
69	15	19,88	4199	4,0	KR002-G63/4a	0,41	14	86	IE1	
84	13	16,18	3946	4,0						
93	11	14,73	3834	4,0						
103	10	13,26	3712	4,0						
123	8,6	11,09	3512	4,0						
145	7,3	9,40	3334	4,0						
170	6,3	8,04	3175	4,0						
183	5,8	7,46	3101	4,0						
0,18 0,25	0,12	12027	7938,12	96372	1,2	KR876-3E71M/6C	0,55	646	174	IE3
	0,13	10648	7017,76	101842	1,4					
	0,16	8974	5902,70	107759	1,7					
	0,19	7644	5018,35	111973	2,0					
	0,22	6560	4299,81	115121	2,3					
	0,24	5943	3891,23	116636	2,5					
	0,27	5193	3396,71	118622	2,9					
	0,31	4585	2996,39	120155	3,3					
	0,35	4081	2665,68	121374	3,7					
	0,39	3658	2387,89	123281	4,0					
	0,45	3175	2074,42	128178	4,0					
	0,37	3766	3597,31	-	0,7	KR576-G63/4b	0,60	156	138	IE1
	0,49	2890	2755,47	20604	0,9					
	0,58	2445	2328,84	25068	1,1					
	0,60	2393	2236,28	25513	1,1	KR575-G63/4b	0,60	152	138	IE1
	0,71	2025	1890,04	28383	1,3					
	1,0	1467	1368,95	31902	1,8					
	1,1	1304	1216,74	32739	2,1					
	1,4	1002	932,00	34264	2,7					
	1,7	848	787,70	34954	3,2					
	0,76	1893	1767,90	12768	0,8	KR475-G63/4b	0,60	110	126	IE1
	0,91	1583	1476,60	16283	1,0					
	1,0	1496	1395,04	17091	1,0					
	1,1	1309	1218,61	18641	1,2					
1,2	1228	1142,99	19241	1,3						
1,4	1045	971,77	20486	1,5						
1,5	971	901,03	20944	1,6						

\*: IE2 ve IE3 motorlu redüktör fiyatları farklıdır. / Geared motor prices are different for IE2 and IE3 motors. / Preise von Getrieben mit IE2 und IE3 Motoren sind unterschiedlich.

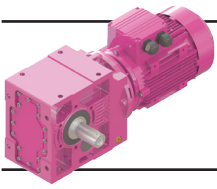

# K Serisi Motorlu Güç Devir Sayfaları

## K Series Geared Motors Performance Tables

### K Serien Getriebemotoren Leistung und Drehzahlübersicht

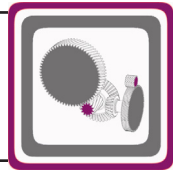

Güç	IE3 Çıkış Devri	IE3 Çıkış Momenti	Çevrim Oranı	IE3 Güv. Rad. Yük Çıkış	IE3 Servis Faktörü	Tipi	Anma Akımı	Ağırlık	Ölçü Sayfası	Motor Verim Snf.*
Power	Output Speeds	Output Torque	Ratio	Per. O. Loads (Output)	Service Factors	Type	Rated Current	Weight	Dim. Page	Motor Eff. Class
Leistung P <sub>g</sub> [kW] P <sub>g</sub> [HP]	Abtriebswelle Drehzahlen n <sub>2</sub> [r.p.m]	Abtriebswelle Drehmomente M <sub>2</sub> [Nm]	Übersetzung i	Zul.Querkräfte (Abtrieb) F <sub>qam</sub> [N]	Betriebsfaktor f <sub>s</sub>	Typ	Nennstrom [A]	Gewicht ~ [kg]	Maße Seite	Motor Effizienz- klasse
0,18 0,25	1,6	909	844,06	21342	1,7	KR475-G63/4b	0,60	110	126	IE1
	2,0	752	472,63	22172	2,1	KR474-3E71M/6C	0,55	100	122	IE3
	2,2	673	422,88	22575	2,3	KR474-2E71M/6B	0,60	99		IE2
	2,5	592	371,35	22937	2,6					
	3,0	495	310,16	23382	3,1					
	3,2	468	293,03	23501	3,3					
	1,2	1174	1094,97	5584	0,7	KR375-G63/4b	0,60	70	114	IE1
	1,4	1038	968,01	8794	0,8					
	1,6	874	814,20	11365	0,9					
	1,9	744	692,22	12924	1,1					
	2,3	638	593,11	13987	1,3					
	2,5	584	367,43	14465	1,4	KR374-3E71M/6C	0,55	62	110	IE3
	3,1	471	295,76	15381	1,7	KR374-2E71M/6B	0,60	61		IE2
	3,6	413	259,36	15796	2,0					
	3,6	406	367,43	15848	2,0	KR374-G63/4b	0,60	59	110	IE1
4,5	327	295,76	16367	2,5						
5,2	287	259,36	16610	2,9						
2,3	616	573,99	10785	0,7	KR275-G63/4b	0,60	29	102	IE1	
2,7	535	498,55	11448	0,8						
3,1	469	436,24	11945	1,0						
3,7	388	360,73	12451	1,2						
4,5	324	300,85	12816	1,4						
5,3	272	252,20	13085	1,7						
6,2	233	215,91	13268	1,9						
6,7	217	200,35	13343	2,1						
8,2	184	113,65	13475	2,4	KR273-3E71M/6C	0,55	30	98	IE3	
9,6	157	96,68	13588	2,9	KR273-2E71M/6B	0,60	29		IE2	
11	136	83,48	13672	3,3						
12	127	113,65	13715	3,5	KR273-G63/4b	0,60	28	98	IE1	
14	109	96,68	13835	4,0						
6,7	236	138,53	8627	1,2	KR203-3E71M/6C	0,55	19	94	IE3	
7,8	204	119,62	9260	1,4	KR203-2E71M/6B	0,60	18		IE2	
8,9	179	104,49	9670	1,6						
9,5	168	98,01	9834	1,7						
9,7	164	138,53	9866	1,7	KR203-G63/4b	0,60	26	94	IE1	
11	141	119,62	9527	2,0						
13	124	104,49	9212	2,3						
14	116	98,01	9063	2,4						
16	99	83,32	8687	2,8						
8,8	179	105,26	4409	0,8	KR103-3E71M/6C	0,55	15	90	IE3	
10	152	88,87	5481	0,9	KR103-2E71M/6B	0,60	14		IE2	
10	152	129,27	5455	0,9	KR103-G63/4b	0,60	15	90	IE1	
12	137	116,34	5902	1,0						
13	124	105,26	6228	1,1						

\*: IE2 ve IE3 motorlu redüktör fiyatları farklıdır. / Geared motor prices are different for IE2 and IE3 motors. / Preise von Getrieben mit IE2 und IE3 Motoren sind unterschiedlich.

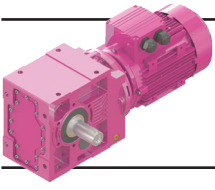

# K Serisi Motorlu Güç Devir Sayfaları

## K Series Geared Motors Performance Tables

### K Serien Getriebemotoren Leistung und Drehzahlübersicht

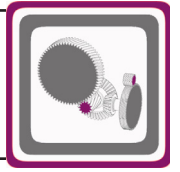

Güç	IE3 Çıkış Devri	IE3 Çıkış Momenti	Çevrim Oranı	IE3 Güv. Rad. Yük Çıkış	IE3 Servis Faktörü	Tipi	Anma Akımı	Ağırlık	Ölçü Sayfası	Motor Verim Snf.*	
Power	Output Speeds	Output Torque	Ratio	Per.O. Loads (Output)	Service Factors	Type	Rated Current	Weight	Dim. Page	Motor Eff. Class	
Leistung P <sub>g</sub> [kW] P <sub>g</sub> [HP]	Abtriebswelle Drehzahlen n <sub>2</sub> [r.p.m]	Abtriebswelle Drehmomente M <sub>2</sub> [Nm]	Übersetzung i	Zul.Querkräfte (Abtrieb) F <sub>qam</sub> [N]	Betriebsfaktor f <sub>s</sub>	Typ	Nennstrom [A]	Gewicht ~ [kg]	Maße Seite	Motor Effizienz-klasse	
0,18 0,25	15	105	88,87	6624	1,3	KR103-G63/4b	0,60	15	90	IE1	
	18	90	76,13	6873	1,6						
	20	80	67,22	7021	1,8						
	21	74	62,79	7086	1,9						
	25	63	53,07	6957	2,2						
	30	53	44,32	6622	2,7						
	35	45	38,22	6353	3,0						
		15	106	89,62	2782	0,8	KR003-G63/4b	0,60	15	86	IE1
		17	95	80,66	3405	0,8					
		20	80	67,44	4058	1,0					
		23	68	57,16	4437	1,2					
		27	58	48,93	4678	1,4					
		30	54	45,41	4765	1,5					
		38	42	35,34	4802	1,9					
		45	36	29,95	4602	2,3					
52		30	25,64	4415	2,6						
56		28	23,79	4326	2,8						
	67	24	19,88	4113	3,4	KR002-G63/4b	0,60	15	86	IE1	
	83	19	16,18	3879	3,9						
	91	18	14,73	3775	4,0						
	101	16	13,26	3661	4,0						
	121	13	11,09	3471	4,0						
	143	11	9,40	3303	4,0						
	167	9,7	8,04	3150	4,0						
	180	9,0	7,46	3079	4,0						
	213	7,5	13,26	2923	4,0	KR002-G63/2a	0,50	10	86	IE1	
	254	6,2	11,09	2764	4,0						
	300	5,3	9,40	2624	4,0						
	351	4,5	8,04	2498	4,0						
	378	4,2	7,46	2440	4,0						
0,25 0,34	0,16	12585	9052,24	93983	1,2	KR876-3E71M/4C	0,67	648	174	IE3	
	0,18	11054	7938,12	100294	1,4						KR876-2E71M/4B
	0,20	9787	7017,76	104980	1,5						
	0,24	8248	5902,70	109927	1,8						
	0,29	7025	5018,35	113658	2,1						
	0,33	6029	4299,81	116464	2,5						
	0,37	5462	3891,23	117976	2,7						
	0,42	4773	3396,71	119816	3,1						
	0,48	4214	2996,39	121167	3,6						
	0,54	3751	2665,68	122163	4,0						
	0,60	3362	2387,89	126388	4,0						
		0,20	9930	7156,22	41071	0,8	KR776-3E71M/4C	0,67	392	162	IE3
		0,22	8858	6380,72	49391	0,9					
		0,26	7801	5610,63	55893	1,0					
		0,32	6287	4516,30	63529	1,3					
		0,36	5522	3960,44	66795	1,4					
		0,41	4889	3501,26	69254	1,6					
		0,69	2961	2066,04	75548	2,7	KR775-3E71M/4C	0,67	392	162	IE3
		0,80	2556	1786,65	76703	3,1					
		0,37	5341	3844,04	13985	0,8	KR676-3E71M/4C	0,67	318	150	IE3
		0,42	4729	3398,35	23714	0,9					

\*: IE2 ve IE3 motorlu redüktör fiyatları farklıdır. / Geared motor prices are different for IE2 and IE3 motors. / Preise von Getrieben mit IE2 und IE3 Motoren sind unterschiedlich.

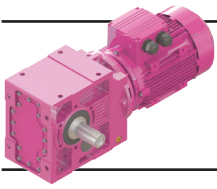

# K Serisi Motorlu Güç Devir Sayfaları

## K Series Geared Motors Performance Tables

### K Serien Getriebemotoren Leistung und Drehzahlübersicht

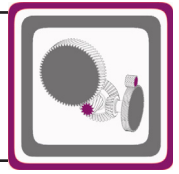

Güç	IE3 Çıkış Devri	IE3 Çıkış Momenti	Çevrim Oranı	IE3 Güv. Rad. Yük Çıkış	IE3 Servis Faktörü	Tipi	Anma Akımı	Ağırlık	Ölçü Sayfası	Motor Verim Snf.*
Power	Output Speeds	Output Torque	Ratio	Per. O. Loads (Output)	Service Factors	Type	Rated Current	Weight	Dim. Page	Motor Eff. Class
Leistung P <sub>g</sub> [kW] P <sub>g</sub> [HP]	Abtriebswelle Drehzahlen n <sub>2</sub> [r.p.m]	Abtriebswelle Drehmomente M <sub>2</sub> [Nm]	Übersetzung i	Zul.Querkräfte (Abtrieb) F <sub>qam</sub> [N]	Betriebsfaktor f <sub>s</sub>	Typ	Nennstrom [A]	Gewicht ~ [kg]	Maße Seite	Motor Effizienz- klasse
0,25 0,34	0,50	3986	<b>2858,39</b>	31305	1,1	<b>KR676-3E71M/4C</b>	0,67	318	150	IE3
	0,59	3395	<b>2430,14</b>	35760	1,3	<b>KR676-2E71M/4B</b>	0,71	317		IE2
	0,69	2914	<b>2082,19</b>	38846	1,5					
	0,77	2679	<b>1875,03</b>	40199	1,6	<b>KR675-3E71M/4C</b>	0,67	316	150	IE3
	0,90	2278	<b>1597,25</b>	42315	1,9	<b>KR675-2E71M/4B</b>	0,71	315		IE2
	1,0	1961	<b>1373,07</b>	43773	2,2					
	1,2	1703	<b>1191,60</b>	44927	2,5					
	1,4	1490	<b>1041,68</b>	45867	2,9					
	1,6	1311	<b>915,75</b>	46541	3,3					
	0,64	3169	<b>2236,28</b>	16952	0,9	<b>KR575-3E71M/4C</b>	0,67	156	138	IE3
	0,76	2681	<b>1890,04</b>	22886	1,0	<b>KR575-2E71M/4B</b>	0,71	155		IE2
	1,0	1942	<b>1368,95</b>	28913	1,4					
	1,2	1727	<b>1216,74</b>	30365	1,6					
	1,5	1327	<b>932,00</b>	32610	2,0					
	1,8	1123	<b>787,70</b>	33654	2,4					
	2,0	1060	<b>469,74</b>	33992	2,5	<b>KR574-3E71M/6D</b>	0,77	164	134	IE3
	2,3	897	<b>397,01</b>	34694	3,0	<b>KR574-2E71M/6C</b>	0,78	163		IE2
	1,0	1981	<b>1395,04</b>	11495	0,8	<b>KR475-3E71M/4C</b>	0,67	113	126	IE3
	1,2	1733	<b>1218,61</b>	14733	0,9	<b>KR475-2E71M/4B</b>	0,71	112		IE2
	1,3	1627	<b>1142,99</b>	15892	1,0					
	1,5	1384	<b>971,77</b>	18047	1,1					
	1,6	1286	<b>901,03</b>	18816	1,2					
	1,7	1204	<b>844,06</b>	19393	1,3					
	2,0	1067	<b>472,63</b>	20346	1,5	<b>KR474-3E71M/6D</b>	0,77	118	122	IE3
	2,2	954	<b>422,88</b>	21045	1,6	<b>KR474-2E71M/6C</b>	0,78	117		IE2
	2,5	839	<b>371,35</b>	21708	1,8					
	3,0	691	<b>472,63</b>	22459	2,2	<b>KR474-3E71M/4C</b>	0,67	98	122	IE3
	3,4	618	<b>422,88</b>	22819	2,5	<b>KR474-2E71M/4B</b>	0,71	97		IE2
	3,9	544	<b>371,35</b>	23170	2,9					
	4,6	455	<b>310,16</b>	23565	3,4					
	2,1	985	<b>692,22</b>	9709	0,8	<b>KR375-3E71M/4C</b>	0,67	72	114	IE3
	2,4	844	<b>593,11</b>	11751	1,0	<b>KR375-2E71M/4B</b>	0,71	71		IE2
	2,5	829	<b>367,43</b>	11952	1,0	<b>KR374-3E71M/6D</b>	0,77	64	110	IE3
	3,1	667	<b>295,76</b>	13705	1,2	<b>KR374-2E71M/6C</b>	0,78	63		IE2
	3,6	586	<b>259,36</b>	14452	1,4					
	3,9	537	<b>367,43</b>	14862	1,5	<b>KR374-3E71M/4C</b>	0,67	64	110	IE3
	4,9	432	<b>295,76</b>	15638	1,9	<b>KR374-2E71M/4B</b>	0,71	63		IE2
	5,5	380	<b>259,36</b>	16006	2,2					
	6,3	342	<b>148,75</b>	16244	2,4	<b>KR373-3E71M/6D</b>	0,77	59	106	IE3
	7,3	293	<b>127,30</b>	16551	2,8	<b>KR373-2E71M/6C</b>	0,78	58		IE2
	8,4	255	<b>110,61</b>	16778	3,2					
	4,0	514	<b>360,73</b>	11610	0,9	<b>KR275-3E71M/4C</b>	0,67	34	102	IE3
	4,8	429	<b>300,85</b>	12197	1,0	<b>KR275-2E71M/4B</b>	0,71	33		IE2
	5,7	360	<b>252,20</b>	12602	1,3					

\*: IE2 ve IE3 motorlu redüktör fiyatları farklıdır. / Geared motor prices are different for IE2 and IE3 motors. / Preise von Getrieben mit IE2 und IE3 Motoren sind unterschiedlich.

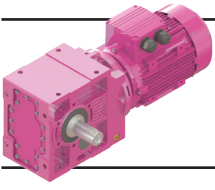

# K Serisi Motorlu Güç Devir Sayfaları

## K Series Geared Motors Performance Tables

### K Serien Getriebemotoren Leistung und Drehzahlübersicht

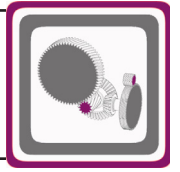

Güç	IE3 Çıkış Devri	IE3 Çıkış Momenti	Çevrim Oranı	IE3 Güv. Rad. Yük Çıkış	IE3 Servis Faktörü	Tipi	Anma Akımı	Ağırlık	Ölçü Sayfası	Motor Verim Snf.*
Power	Output Speeds	Output Torque	Ratio	Per.O. Loads (Output)	Service Factors	Type	Rated Current	Weight	Dim. Page	Motor Eff. Class
Leistung P <sub>g</sub> [kW] P <sub>g</sub> [HP]	Abtriebswelle Drehzahlen n <sub>2</sub> [r.p.m]	Abtriebswelle Drehmomente M <sub>2</sub> [Nm]	Übersetzung i	Zul.Querkräfte (Abtrieb) F <sub>qam</sub> [N]	Betriebsfaktor f <sub>s</sub>	Typ	Nennstrom [A]	Gewicht ~ [kg]	Maße Seite	Motor Effizienz-klasse
0,25 0,34	6,6	309	215,91	12885	1,5	KR275-3E71M/4C	0,67	34	102	IE3
	7,2	287	200,35	12999	1,6	KR275-2E71M/4B	0,71	33		IE2
8,2 9,6 11	262	113,65	13120	1,7	KR273-3E71M/6D	0,77	24	98	IE3	
	223	96,68	13304	2,0	KR273-2E71M/6C	0,78	23		IE2	
	193	83,48	13438	2,3						
	169	113,65	13539	2,7	KR273-3E71M/4C	0,67	32	98	IE3	
13 15 17 20	144	96,68	13640	3,1	KR273-2E71M/4B	0,71	31		IE2	
	125	83,48	13715	3,6						
	109	72,92	13811	4,0						
	169	113,65	13539	2,7	KR273-3E71M/4C	0,67	32	98	IE3	
6,7 7,8 8,9 9,5	329	138,53	5687	0,9	KR203-3E71M/6D	0,77	30	94	IE3	
	284	119,62	7369	1,0	KR203-2E71M/6C	0,78	29		IE2	
	249	104,49	8343	1,1						
	233	98,01	8691	1,2						
10 12 14 15 17 20 23 27	213	138,53	9100	1,3	KR203-3E71M/4C	0,67	29	94	IE3	
	184	119,62	8885	1,5	KR203-2E71M/4B	0,71	28		IE2	
	161	104,49	8634	1,7						
	151	98,01	8512	1,9						
	129	83,32	8200	2,2						
	112	72,37	7923	2,5						
	98	63,33	7660	2,9						
	81	52,37	7287	3,5						
12 14 16 19 21 23 27 32 38 41 44 52	179	116,34	4438	0,8	KR103-3E71M/4C	0,67	16	90	IE3	
	162	105,26	5147	0,9	KR103-2E71M/4B	0,71	15		IE2	
	137	88,87	5917	1,0						
	117	76,13	6381	1,2						
	104	67,22	6648	1,4						
	97	62,79	6765	1,4						
	82	53,07	6580	1,7						
	68	44,32	6290	2,0						
	59	38,22	6052	2,3						
	54	35,22	5922	2,5						
	51	32,90	5814	2,6						
	43	27,81	5551	2,9						
56 68 75	40	25,50	6012	3,0	KR102-3E71M/4C	0,67	16	90	IE3	
	33	21,25	5638	3,5	KR102-2E71M/4B	0,71	15		IE2	
	30	19,13	5434	3,7						
21 25 29 32 41 48 56 60	104	67,44	2913	0,8	KR003-3E71M/4C	0,67	16	86	IE3	
	88	57,16	3732	0,9	KR003-2E71M/4B	0,71	15		IE2	
	75	48,93	4200	1,1						
	70	45,41	4366	1,1						
	55	35,34	4498	1,5						
	46	29,95	4334	1,7						
	40	25,64	4176	2,0						
	37	23,79	4100	2,2						
72 89 97 108 129	31	19,88	3912	2,6	KR002-3E71M/4C	0,67	15	86	IE3	
	25	16,18	3704	3,0	KR002-2E71M/4B	0,71	14		IE2	
	23	14,73	3610	3,2						
	21	13,26	3507	3,6						
	17	11,09	3334	4,0						

\*: IE2 ve IE3 motorlu redüktör fiyatları farklıdır. / Geared motor prices are different for IE2 and IE3 motors. / Preise von Getrieben mit IE2 und IE3 Motoren sind unterschiedlich.

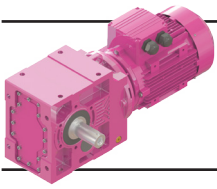

## K Serisi Motorlu Güç Devir Sayfaları

### K Series Geared Motors Performance Tables

#### K Serien Getriebemotoren Leistung und Drehzahlübersicht

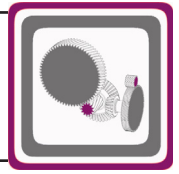

Güç	IE3 Çıkış Devri	IE3 Çıkış Momenti	Çevrim Oranı	IE3 Güv. Rad. Yük Çıkış	IE3 Servis Faktörü	Tipi	Anma Akımı	Ağırlık	Ölçü Sayfası	Motor Verim Snf.*
Power	Output Speeds	Output Torque	Ratio	Per. O. Loads (Output)	Service Factors	Type	Rated Current	Weight	Dim. Page	Motor Eff. Class
Leistung P <sub>g</sub> [kW] P <sub>g</sub> [HP]	Abtriebswelle Drehzahlen n <sub>2</sub> [r.p.m]	Abtriebswelle Drehmomente M <sub>2</sub> [Nm]	Übersetzung i	Zul.Querkräfte (Abtrieb) F <sub>qam</sub> [N]	Betriebsfaktor f <sub>s</sub>	Typ	Nennstrom [A]	Gewicht ~ [kg]	Maße Seite	Motor Effizienz-klasse
0,25 0,34	153	15	9,40	3178	4,0	KR002-3E71M/4C	0,67	15	86	IE3
	178	13	8,04	3036	4,0	KR002-2E71M/4B	0,71	14		IE2
	192	12	7,46	2970	4,0					
	193	12	14,73	2969	4,0	KR002-G63/2b	0,67	15	86	IE1
	214	10	13,26	2877	4,0					
	256	8,7	11,09	2725	4,0					
	302	7,4	9,40	2590	4,0					
	353	6,3	8,04	2469	4,0					
	380	5,8	7,46	2412	4,0					
	0,37 0,50	0,24	12585	5902,70	93986	1,2	KR876-3E71M/4D	0,97	648	174
0,29		10719	5018,35	101578	1,4	KR876-2E71M/4C	1,00	647		IE2
0,33		9199	4299,81	107005	1,6					
0,37		8334	3891,23	109836	1,8					
0,42		7282	3396,71	112900	2,1					
0,48		6429	2996,39	115362	2,3					
0,54		5723	2665,68	117288	2,6					
0,60		5130	2387,89	118834	2,9					
0,69		4453	2074,42	120596	3,4					
0,76		4136	1891,08	121282	3,6	KR875-3E71M/4D	0,97	646	174	IE3
0,86		3661	1671,18	123252	4,0	KR875-2E71M/4C	1,00	645		IE2
0,96		3276	1495,27	127227	4,0					
0,32		9593	4516,30	43792	0,8	KR776-3E71M/4D	0,97	390	162	IE3
0,36		8426	3960,44	52309	0,9	KR776-2E71M/4C	1,00	389		IE2
0,41		7460	3501,26	57772	1,1					
0,69		4518	2066,04	70492	1,8	KR775-3E71M/4D	0,97	388	162	IE3
0,80		3900	1786,65	72622	2,1	KR775-2E71M/4C	1,00	387		IE2
0,93		3380	1547,01	74285	2,4					
1,1		2959	1353,02	75554	2,7					
1,2		2611	1192,77	76552	3,1					
0,59		5180	2430,14	17163	0,8	KR676-3E71M/4D	0,97	230	150	IE3
0,69		4446	2082,19	26845	1,0	KR676-2E71M/4C	1,00	229		IE2
0,77		4088	1875,03	30390	1,1	KR675-3E71M/4D	0,97	247	150	IE3
0,90		3476	1597,25	35191	1,2	KR675-2E71M/4C	1,00	246		IE2
1,0	2991	1373,07	38300	1,4						
1,2	2598	1191,60	40646	1,7						
1,4	2273	1041,68	42341	1,9						
1,6	2000	915,75	43590	2,2						
1,8	1770	809,27	44633	2,4						
2,0	1584	724,08	45432	2,7						
2,3	1394	635,86	46212	3,1						
1,0	2963	1368,95	19659	0,9	KR575-3E71M/4D	0,97	156	138	IE3	
1,2	2635	1216,74	23352	1,0	KR575-2E71M/4C	1,00	155		IE2	
1,5	2025	932,00	28381	1,3						
1,8	1713	787,70	30450	1,6						
2,0	1618	469,74	31010	1,7	KR574-3E80M/6B	1,03	161	134	IE3	
2,3	1369	397,01	32395	2,0	KR574-2E80M/6A	1,08	160		IE2	
2,8	1136	328,56	33599	2,4						

\*: IE2 ve IE3 motorlu redüktör fiyatları farklıdır. / Geared motor prices are different for IE2 and IE3 motors. / Preise von Getrieben mit IE2 und IE3 Motoren sind unterschiedlich.



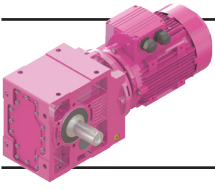

# K Serisi Motorlu Güç Devir Sayfaları

## K Series Geared Motors Performance Tables

### K Serien Getriebemotoren Leistung und Drehzahlübersicht

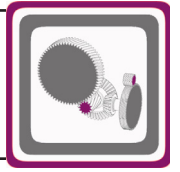

Güç	IE3 Çıkış Devri	IE3 Çıkış Momenti	Çevrim Oranı	IE3 Güv. Rad. Yük Çıkış	IE3 Servis Faktörü	Tipi	Anma Akımı	Ağırlık	Ölçü Sayfası	Motor Verim Snf.*
Power	Output Speeds	Output Torque	Ratio	Per.O. Loads (Output)	Service Factors	Type	Rated Current	Weight	Dim. Page	Motor Eff. Class
Leistung P <sub>g</sub> [kW] P <sub>g</sub> [HP]	Abtriebswelle Drehzahlen n <sub>2</sub> [r.p.m]	Abtriebswelle Drehmomente M <sub>2</sub> [Nm]	Übersetzung i	Zul.Querkräfte (Abtrieb) F <sub>qam</sub> [N]	Betriebsfaktor f <sub>s</sub>	Typ	Nennstrom [A]	Gewicht ~ [kg]	Maße Seite	Motor Effizienz-klasse
0,37 0,50	3,1	1049	469,74	34013	2,6	KR574-3E71M/4D	0,97	153	134	IE3
	3,6	887	397,01	34755	3,0	KR574-2E71M/4C	1,00	152		IE2
	2,0	1628	472,63	15838	1,0	KR474-3E80M/6B	1,03	100	122	IE3
	2,2	1456	422,88	17441	1,1	KR474-2E80M/6A	1,08	99		IE2
	2,5	1280	371,35	18861	1,2					
	3,0	1055	472,63	20423	1,5	KR474-3E71M/4D	0,97	98	122	IE3
	3,4	944	422,88	21109	1,6	KR474-2E71M/4C	1,00	97		IE2
	3,9	830	371,35	21728	1,9					
	4,6	694	310,16	22447	2,2					
	4,9	656	293,03	22637	2,4					
	6,1	540	153,47	23177	2,9	KR473-3E80M/6B	1,03	93	118	IE3
	6,8	478	135,98	23477	3,2	KR473-2E80M/6A	1,08	92		IE2
	8,4	390	110,65	23849	4,0					
	3,1	1018	295,76	9149	0,8	KR374-3E80M/6B	1,03	66	110	IE3
	3,6	894	259,36	11098	0,9	KR374-2E80M/6A	1,08	65		IE2
	3,9	819	367,43	12058	1,0	KR374-3E71M/4D	0,97	64	110	IE3
	4,9	660	295,76	13757	1,2	KR374-2E71M/4C	1,00	63		IE2
	5,5	579	259,36	14509	1,4					
	6,3	513	229,29	15058	1,6					
	7,3	447	127,30	15535	1,8	KR373-3E80M/6B	1,03	62	106	IE3
	8,4	389	110,61	15946	2,1	KR373-2E80M/6A	1,08	61		IE2
	9,6	339	148,75	16272	2,4	KR373-3E71M/4D	0,97	60	106	IE3
	11	291	127,30	16574	2,8	KR373-2E71M/4C	1,00	59		IE2
	13	253	110,61	16807	3,2					
	4,8	654	300,85	10434	0,7	KR275-3E71M/4D	0,97	34	102	IE3
	5,7	549	252,20	11342	0,8	KR275-2E71M/4C	1,00	33		IE2
	6,6	471	215,91	11916	1,0					
	7,2	438	200,35	12141	1,0					
	9,6	340	96,68	12719	1,3	KR273-3E80M/6B	1,03	44	98	IE3
	11	294	83,48	12966	1,5	KR273-2E80M/6A	1,08	43		IE2
	13	259	113,65	13136	1,7	KR273-3E71M/4D	0,97	34	98	IE3
	15	221	96,68	13317	2,0	KR273-2E71M/4C	1,00	33		IE2
	17	191	83,48	13449	2,4					
	20	167	72,92	13549	2,7					
	21	157	68,40	13591	2,9					
	25	133	58,15	13683	3,4					
	28	116	50,51	13749	3,9					
	32	101	44,20	13953	4,0					
	9,5	345	98,01	4860	0,8	KR203-3E80M/6B	1,03	33	94	IE3
						KR203-2E80M/6A	1,08	32		IE2
	10	316	138,53	6243	0,9	KR203-3E71M/4D	0,97	30	94	IE3
						KR203-2E71M/4C	1,00	29		IE2

\*: IE2 ve IE3 motorlu redüktör fiyatları farklıdır. / Geared motor prices are different for IE2 and IE3 motors. / Preise von Getrieben mit IE2 und IE3 Motoren sind unterschiedlich.

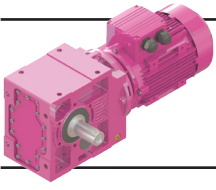

## K Serisi Motorlu Güç Devir Sayfaları

### K Series Geared Motors Performance Tables

### K Serien Getriebemotoren Leistung und Drehzahlübersicht

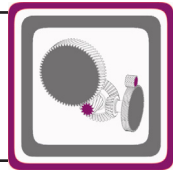

Güç	IE3 Çıkış Devri	IE3 Çıkış Momenti	Çevrim Oranı	IE3 Güv. Rad. Yük Çıkış	IE3 Servis Faktörü	Tipi	Anma Akımı	Ağırlık	Ölçü Sayfası	Motor Verim Snf.*
Power	Output Speeds	Output Torque	Ratio	Per. O. Loads (Output)	Service Factors	Type	Rated Current	Weight	Dim. Page	Motor Eff. Class
Leistung P <sub>g</sub> [kW] P <sub>g</sub> [HP]	Abtriebswelle Drehzahlen n <sub>2</sub> [r.p.m]	Abtriebswelle Drehmomente M <sub>2</sub> [Nm]	Übersetzung i	Zul.Querkräfte (Abtrieb) F <sub>qam</sub> [N]	Betriebsfaktor f <sub>s</sub>	Typ	Nennstrom [A]	Gewicht ~ [kg]	Maße Seite	Motor Effizienz-klasse
0,37 0,50	12	273	119,62	7697	1,0	KR203-3E71M/4D	0,97	30	94	IE3
	14	239	104,49	7890	1,2	KR203-2E71M/4C	1,00	29		IE2
	15	224	98,01	7817	1,2					
	17	191	83,32	7616	1,5					
	20	166	72,37	7420	1,7					
	23	145	63,33	7223	1,9					
	27	120	52,37	6929	2,3					
	33	100	43,67	6640	2,8					
	38	88	38,16	6424	3,2					
		19	174	76,13	4642	0,8	KR103-3E71M/4D	0,97	17	90
	21	154	67,22	5410	0,9	KR103-2E71M/4C	1,00	16		IE2
	23	144	62,79	5721	1,0					
	27	121	53,07	6138	1,2					
	32	102	44,32	5925	1,4					
	38	88	38,22	5740	1,5					
	41	81	35,22	5636	1,7					
	44	76	32,90	5548	1,7					
	52	64	27,81	5328	2,0					
	56	59	25,50	6095	2,0	KR102-3E71M/4D	0,97	17	90	IE3
	68	49	21,25	5709	2,3	KR102-2E71M/4C	1,00	16		IE2
	75	44	19,13	5498	2,5					
	83	40	17,30	5306	2,7					
	98	34	14,61	4997	3,2					
	32	104	45,41	2897	0,8	KR003-3E71M/4D	0,97	16	86	IE3
	41	81	35,34	4010	1,0	KR003-2E71M/4C	1,00	15		IE2
	48	69	29,95	4004	1,2					
	56	59	25,64	3897	1,4					
	60	55	23,79	3842	1,5					
	72	46	19,88	3696	1,7	KR002-3E71M/4D	0,97	16	86	IE3
	89	38	16,18	3530	2,0	KR002-2E71M/4C	1,00	15		IE2
	97	34	14,73	3453	2,2					
	108	31	13,26	3366	2,4					
	129	26	11,09	3217	2,9					
	153	22	9,40	3080	3,2					
	178	19	8,04	2952	3,5					
	192	17	7,46	2892	3,7					
	192	17	14,73	2894	3,5	KR002-3E71M/2B	0,86	15	86	IE3
	213	16	13,26	2810	3,9	KR002-2E71M/2A	0,90	14		IE2
	255	13	11,09	2670	4,0					
	301	11	9,40	2544	4,0					
	352	9,5	8,04	2430	4,0					
	379	8,8	7,46	2376	4,0					
0,55 0,75	0,43	10713	3396,71	101600	1,4	KR876-3E80M/4C	1,34	655	174	IE3
	0,48	9458	2996,39	106126	1,6	KR876-2E80M/4B	1,45	654		IE2
	0,54	8419	2665,68	109566	1,8					
	0,61	7546	2387,89	112266	2,0					
	0,70	6550	2074,42	115149	2,3					
	0,77	6084	1891,08	116259	2,5	KR875-3E80M/4C	1,34	651	174	IE3
	0,87	5385	1671,18	118129	2,8	KR875-2E80M/4B	1,45	650		IE2
	0,97	4820	1495,27	119576	3,1					
	1,1	4240	1313,07	121000	3,5					
	1,3	3549	1096,71	124461	4,0					

\*: IE2 ve IE3 motorlu redüktör fiyatları farklıdır. / Geared motor prices are different for IE2 and IE3 motors. / Preise von Getrieben mit IE2 und IE3 Motoren sind unterschiedlich.

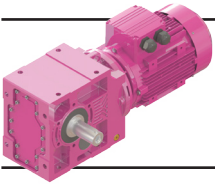

# K Serisi Motorlu Güç Devir Sayfaları

## K Series Geared Motors Performance Tables

### K Serien Getriebemotoren Leistung und Drehzahlübersicht

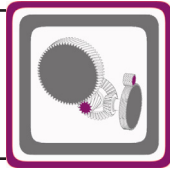

Güç	IE3 Çıkış Devri	IE3 Çıkış Momenti	Çevrim Oranı	IE3 Güv. Rad. Yük Çıkış	IE3 Servis Faktörü	Tipi	Anma Akımı	Ağırlık	Ölçü Sayfası	Motor Verim Snf.*
Power	Output Speeds	Output Torque	Ratio	Per.O. Loads (Output)	Service Factors	Type	Rated Current	Weight	Dim. Page	Motor Eff. Class
Leistung P <sub>g</sub> [kW] P <sub>g</sub> [HP]	Abtriebswelle Drehzahlen n <sub>2</sub> [r.p.m]	Abtriebswelle Drehmomente M <sub>2</sub> [Nm]	Übersetzung i	Zul.Querkräfte (Abtrieb) F <sub>qam</sub> [N]	Betriebsfaktor f <sub>s</sub>	Typ	Nennstrom [A]	Gewicht ~ [kg]	Maße Seite	Motor Effizienz-klasse
0,55 0,75	1,5	3102	957,34	128847	4,0	KR875-3E80M/4C KR875-2E80M/4B	1,34 1,45	651 650	174	IE3 IE2
	0,70 0,81 0,94 1,1 1,2 1,4 1,5 1,7 1,9	6646 5737 4973 4353 3840 3409 3042 2693 2410	2066,04 1786,65 1547,01 1353,02 1192,77 1058,16 943,49 833,78 746,01	61869 65911 68941 71183 72906 74160 75280 76295 77083	1,2 1,4 1,6 1,8 2,1 2,3 2,6 3,0 3,3	KR775-3E80M/4C KR775-2E80M/4B	1,34 1,45	393 392	162	IE3 IE2
	0,91 1,1 1,2 1,4 1,6 1,8 2,0 2,3	5114 4401 3822 3344 2942 2604 2331 2051	1597,25 1373,07 1191,60 1041,68 915,75 809,27 724,08 635,86	18299 27374 32584 36109 38680 40614 42051 43418	0,8 1,0 1,1 1,3 1,5 1,7 1,8 2,1	KR675-3E80M/4C KR675-2E80M/4B	1,34 1,45	320 319	150	IE3 IE2
	2,6 2,9 3,4 4,0	1867 1652 1406 1210	363,81 321,51 273,88 235,44	44261 45193 46204 46959	2,3 2,6 3,1 3,6	KR674-3E80M/6C KR674-2E80M/6B	1,47 1,50	206 205	146	IE3 IE2
	1,6 1,8	2979 2521	932,00 787,70	19523 24386	0,9 1,1	KR575-3E80M/4C KR575-2E80M/4B	1,34 1,45	154 153	138	IE3 IE2
	2,0 2,4 2,8	2392 2025 1680	469,74 397,01 328,56	25521 28384 30658	1,1 1,3 1,6	KR574-3E80M/6C KR574-2E80M/6B	1,47 1,50	158 157	134	IE3 IE2
	3,1 3,7 4,4 5,2 5,9	1543 1305 1083 927 814	469,74 397,01 328,56 281,00 246,42	31472 32773 33884 34563 35063	1,8 2,1 2,5 2,9 3,3	KR574-3E80M/4C KR574-2E80M/4B	1,34 1,45	155 154	134	IE3 IE2
	2,5	1893	371,35	12782	0,8	KR474-3E80M/6C KR474-2E80M/6B	1,47 1,45	102 101	122	IE3 IE2
	3,1 3,4 3,9 4,7 4,9	1552 1388 1220 1021 965	472,63 422,88 371,35 310,16 293,03	16587 18011 19300 20640 20983	1,0 1,1 1,3 1,5 1,6	KR474-3E80M/4C KR474-2E80M/4B	1,34 1,45	101 100	122	IE3 IE2
	6,1 6,9 8,4	800 709 578	153,47 135,98 110,65	21919 22395 23030	1,9 2,2 2,7	KR473-3E80M/6C KR473-2E80M/6B	1,47 1,50	94 93	118	IE3 IE2
	9,4 11	517 458	153,47 135,98	23280 23565	3,0 3,4	KR473-3E80M/4C KR473-2E80M/4B	1,34 1,45	94 93	118	IE3 IE2

\*: IE2 ve IE3 motorlu redüktör fiyatları farklıdır. / Geared motor prices are different for IE2 and IE3 motors. / Preise von Getrieben mit IE2 und IE3 Motoren sind unterschiedlich.

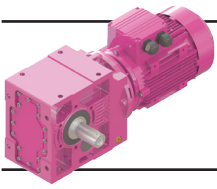

# K Serisi Motorlu Güç Devir Sayfaları

## K Series Geared Motors Performance Tables

### K Serien Getriebemotoren Leistung und Drehzahlübersicht

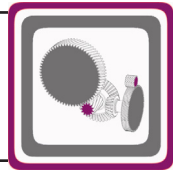

Güç	IE3 Çıkış Devri	IE3 Çıkış Momenti	Çevrim Oranı	IE3 Güv. Rad. Yük Çıkış	IE3 Servis Faktörü	Tipi	Anma Akımı	Ağırlık	Ölçü Sayfası	Motor Verim Snf.*
Power	Output Speeds	Output Torque	Ratio	Per.O. Loads (Output)	Service Factors	Type	Rated Current	Weight	Dim. Page	Motor Eff. Class
Leistung P <sub>g</sub> [kW] P <sub>g</sub> [HP]	Abtriebswelle Drehzahlen n <sub>2</sub> [r.p.m.]	Abtriebswelle Drehmomente M <sub>2</sub> [Nm]	Übersetzung i	Zul.Querkräfte (Abtrieb) F <sub>qam</sub> [N]	Betriebsfaktor f <sub>s</sub>	Typ	Nennstrom [A]	Gewicht ~ [kg]	Maße Seite	Motor Effizienz- klasse
0,55 0,75	13	373	110,65	24142	4,0	KR473-3E80M/4C KR473-2E80M/4B	1,34 1,45	94 93	118	IE3 IE2
	4,9 5,6 6,3	971 852 754	295,76 259,36 229,29	9956 11651 12812	0,8 1,0 1,1	KR374-3E80M/4C KR374-2E80M/4B	1,34 1,45	67 66	110	IE3 IE2
	7,3 8,5 9,6	663 577 508	127,30 110,61 97,26	13748 14514 16830	1,2 1,4 1,6	KR373-3E80M/6C KR373-2E80M/6B	1,47 1,50	64 63	106	IE3 IE2
	11 13 15 19	428 372 328 264	127,30 110,61 97,26 78,29	15691 16072 16338 16727	1,9 2,2 2,5 3,1	KR373-3E80M/4C KR373-2E80M/4B	1,34 1,45	63 62	106	IE3 IE2
	7,2	644	200,35	10534	0,7	KR275-3E80M/4C KR275-2E80M/4B	1,34 1,45	38 37	102	IE3 IE2
	9,7 11 13	504 435 381	96,68 83,48 72,92	11685 12163 12494	0,9 1,0 1,2	KR273-3E80M/6C KR273-2E80M/6B	1,47 1,50	35 34	98	IE3 IE2
	15 17 20 21 25 29 33 40 48	325 281 246 231 196 171 149 124 103	96,68 83,48 72,92 68,40 58,15 50,51 44,20 36,55 30,48	12809 13023 13197 13268 13423 13532 13618 13718 13923	1,4 1,6 1,8 1,9 2,3 2,6 3,0 3,6 4,0	KR273-3E80M/4C KR273-2E80M/4B	1,34 1,45	37 36	98	IE3 IE2
	14 15 17 20 23 28 33 38 46 55	352 330 281 244 214 177 148 129 107 89	104,49 98,01 83,32 72,37 63,33 52,37 43,67 38,16 31,55 26,31	4449 5626 6693 6625 6533 6363 6170 6014 5779 5545	0,8 0,8 1,0 1,1 1,3 1,6 1,9 2,2 2,6 3,0	KR203-3E80M/4C KR203-2E80M/4B	1,34 1,45	33 32	94	IE3 IE2
61	82	23,79	6415	3,4	KR202-3E80M/4C KR202-2E80M/4B	1,34 1,45	33 32	94	IE3 IE2	
	27 33 38 41 44 52	179 150 129 119 111 94	53,07 44,32 38,22 35,22 32,90 27,81	4428 5348 5246 5182 5125 4972	0,8 0,9 1,0 1,1 1,2 1,3	KR103-3E80M/4C KR103-2E80M/4B	1,34 1,45	20 19	90	IE3 IE2
	57 68	87 73	25,50 21,25	6186 5786	1,4 1,6	KR102-3E80M/4C KR102-2E80M/4B	1,34 1,45	20 19	90	IE3 IE2

\*: IE2 ve IE3 motorlu redüktör fiyatları farklıdır. / Geared motor prices are different for IE2 and IE3 motors. / Preise von Getrieben mit IE2 und IE3 Motoren sind unterschiedlich.

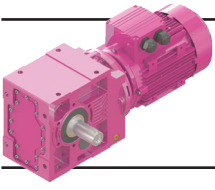

# K Serisi Motorlu Güç Devir Sayfaları

## K Series Geared Motors Performance Tables

### K Serien Getriebemotoren Leistung und Drehzahlübersicht

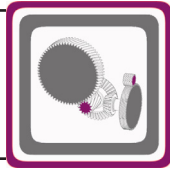

Güç	IE3 Çıkış Devri	IE3 Çıkış Momenti	Çevrim Oranı	IE3 Güv. Rad. Yük Çıkış	IE3 Servis Faktörü	Tipi	Anma Akımı	Ağırlık	Ölçü Sayfası	Motor Verim Snf.*
Power	Output Speeds	Output Torque	Ratio	Per.O. Loads (Output)	Service Factors	Type	Rated Current	Weight	Dim. Page	Motor Eff. Class
Leistung P <sub>g</sub> [kW] P <sub>g</sub> [HP]	Abtriebswelle Drehzahlen n <sub>2</sub> [r.p.m]	Abtriebswelle Drehmomente M <sub>2</sub> [Nm]	Übersetzung i	Zul.Querkräfte (Abtrieb) F <sub>qam</sub> [N]	Betriebsfaktor f <sub>s</sub>	Typ	Nennstrom [A]	Gewicht ~ [kg]	Maße Seite	Motor Effizienz-klasse
0,55 0,75	76	66	19,13	5567	1,7	KR102-3E80M/4C	1,34	20	90	IE3
	84	59	17,30	5368	1,9	KR102-2E80M/4B	1,45	19		IE2
	99	50	14,61	5050	2,2					
	116	43	12,51	4776	2,4					
	131	38	11,05	4568	2,6					
	140	35	10,32	4458	2,8					
	166	30	8,72	4200	3,2					
	48	101	29,95	3075	0,8	KR003-3E80M/4C	1,34	19	86	IE3
	57	87	25,64	3454	0,9	KR003-2E80M/4B	1,45	18		IE2
	61	80	23,79	3433	1,0					
	73	68	19,88	3355	1,2	KR002-3E80M/4C	1,34	19	86	IE3
	90	55	16,18	3255	1,4	KR002-2E80M/4B	1,45	18		IE2
	98	51	14,73	3203	1,5					
	109	45	13,26	3141	1,7					
	131	38	11,09	3029	2,0					
	154	32	9,40	2921	2,2					
	180	28	8,04	2816	2,3					
	194	26	7,46	2765	2,5					
	192	26	14,73	2775	2,3	KR002-3E71M/2C	1,19	16	86	IE3
	213	23	13,26	2703	2,6	KR002-2E71M/2B	1,25	15		IE2
255	19	11,09	2581	3,1						
301	17	9,40	2469	3,3						
352	14	8,04	2366	3,9						
379	13	7,46	2316	4,0						
0,75 1,0	0,48	12897	2996,39	92600	1,2	KR876-3E80M/4D	1,77	653	174	IE3
	0,54	11481	2665,68	98610	1,3	KR876-2E80M/4C	1,89	651		IE2
	0,61	10290	2387,89	103170	1,5					
	0,70	8932	2074,42	107899	1,7					
	0,77	8296	1891,08	109774	1,8	KR875-3E80M/4D	1,77	651	174	IE3
	0,87	7344	1671,18	112719	2,0	KR875-2E80M/4C	1,89	649		IE2
	0,97	6572	1495,27	114961	2,3					
	1,1	5781	1313,07	117134	2,6					
	1,3	4840	1096,71	119567	3,1					
	1,5	4230	957,34	121059	3,5					
1,7	3735	844,51	122416	4,0						
1,9	3326	751,30	126745	4,0						
	0,70	9063	2066,04	47924	0,9	KR775-3E80M/4D	1,77	393	162	IE3
	0,81	7823	1786,65	55767	1,0	KR775-2E80M/4C	1,89	391		IE2
	0,94	6781	1547,01	61224	1,2					
	0,70	9108	1353,02	47716	0,9					
	1,2	5237	1192,77	67929	1,5					
	1,4	4649	1058,16	70135	1,7					
	1,5	4148	943,49	71790	1,9					
	1,7	3672	833,78	73367	2,2					
	1,9	3286	746,01	74575	2,4					
	2,2	2891	655,11	75752	2,8					
2,4 2,7 3,0	2751	396,00	76168	2,9	KR774-3E90S/6B	1,96	407	158	IE3	
	2462	354,32	76974	3,2	KR774-2E90S/6A	2,00	405		IE2	
	2166	311,14	77769	3,7						

\*: IE2 ve IE3 motorlu redüktör fiyatları farklıdır. / Geared motor prices are different for IE2 and IE3 motors. / Preise von Getrieben mit IE2 und IE3 Motoren sind unterschiedlich.

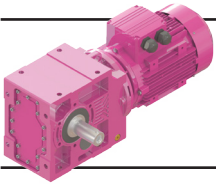

# K Serisi Motorlu Güç Devir Sayfaları

## K Series Geared Motors Performance Tables

### K Serien Getriebemotoren Leistung und Drehzahlübersicht

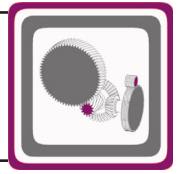

Güç	IE3 Çıkış Devri	IE3 Çıkış Momenti	Çevrim Oranı	IE3 Güv. Rad. Yük Çıkış	IE3 Servis Faktörü	Tipi	Anma Akımı	Ağırlık	Ölçü Sayfası	Motor Verim Sınıfı*
Power	Output Speeds	Output Torque	Ratio	Per. O. Loads (Output)	Service Factors	Type	Rated Current	Weight	Dim. Page	Motor Eff. Class
Leistung P <sub>g</sub> [kW] P <sub>g</sub> [HP]	Abtriebswelle Drehzahlen n <sub>2</sub> [r.p.m]	Abtriebswelle Drehmomente M <sub>2</sub> [Nm]	Übersetzung i	Zul.Querkräfte (Abtrieb) F <sub>qam</sub> [N]	Betriebsfaktor f <sub>s</sub>	Typ	Nennstrom [A]	Gewicht ~ [kg]	Maße Seite	Motor Effizienz- klasse
0,75 1,0	1,2	5212	1191,60	16574	0,8	KR675-3E80M/4D	1,77	321	150	IE3
	1,4	4560	1041,68	25595	0,9	KR675-2E80M/4C	1,89	319		IE2
	1,6	4012	915,75	31082	1,1					
	1,8	3551	809,27	34652	1,2					
	2,0	3178	724,08	37206	1,4					
	2,3	2796	635,86	39536	1,5					
	2,6	2519	363,81	41003	1,7	KR674-3E90S/6B	1,96	301	146	IE3
	2,9	2229	321,51	42498	1,9	KR674-2E90S/6A	2,00	209		IE2
	3,5	1897	273,88	44120	2,3					
	4,0	1641	363,81	45192	2,6	KR674-3E80M/4D	1,77	296	146	IE3
	4,5	1453	321,51	45975	3,0	KR674-2E80M/4C	1,89	294		IE2
	5,3	1236	273,88	46829	3,5					
	2,0	3228	469,74	15989	0,8	KR574-3E90S/6B	1,96	159	134	IE3
	2,4	2732	397,01	22409	1,0	KR574-2E90S/6A	2,00	157		IE2
	2,9	2266	328,56	26563	1,2					
	3,1	2104	469,74	27812	1,3	KR574-3E80M/4D	1,77	156	134	IE3
	3,7	1780	397,01	30031	1,5	KR574-2E80M/4C	1,89	154		IE2
	4,4	1477	328,56	31845	1,8					
	5,2	1264	281,00	32943	2,1					
	5,9	1110	246,42	33716	2,4					
	6,1	1071	237,97	33906	2,5					
	6,9	953	211,51	34460	2,8					
	3,4	1893	422,88	12714	0,8	KR474-3E80M/4D	1,77	103	122	IE3
	3,9	1664	371,35	15500	0,9	KR474-2E80M/4C	1,89	101		IE2
	4,7	1392	310,16	17982	1,1					
	4,9	1316	293,03	18590	1,2					
	6,2	1079	153,47	20234	1,4	KR473-3E90S/6B	1,96	99	118	IE3
	6,9	956	135,98	21039	1,6	KR473-2E90S/6A	2,00	97		IE2
	8,5	779	110,65	22009	2,0					
	9,4	706	153,47	22412	2,2	KR473-3E80M/4D	1,77	95	118	IE3
	11	625	135,98	22807	2,5	KR473-2E80M/4C	1,89	93		IE2
	13	510	110,65	23324	3,0					
	15	451	97,79	23564	3,4					
	6,3	1028	229,29	8932	0,8	KR374-3E80M/4D	1,77	68	110	IE3
						KR374-2E80M/4C	1,89	66		IE2
	8,5	778	110,61	12550	1,1	KR373-3E90S/6B	1,96	68	106	IE3
	9,7	684	97,26	16200	1,2	KR373-2E90S/6A	2,00	66		IE2
	11	584	127,30	14463	1,4	KR373-3E80M/4D	1,77	64	106	IE3
	13	509	110,61	15090	1,6	KR373-2E80M/4C	1,89	62		IE2
	15	448	97,26	15527	1,8					
	19	361	78,29	16133	2,3					
	21	317	68,65	16415	2,6					
	24	280	60,69	16637	2,9					
	11	587	83,48	11033	0,8	KR273-3E90S/6B	1,96	36	98	IE3
	13	513	72,92	11614	0,9	KR273-2E90S/6A	2,00	38		IE2

\*: IE2 ve IE3 motorlu redüktör fiyatları farklıdır. / Geared motor prices are different for IE2 and IE3 motors. / Preise von Getrieben mit IE2 und IE3 Motoren sind unterschiedlich.

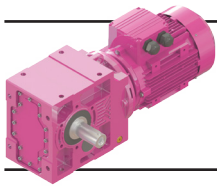

# K Serisi Motorlu Güç Devir Sayfaları

## K Series Geared Motors Performance Tables

### K Serien Getriebemotoren Leistung und Drehzahlübersicht

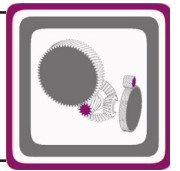

Güç	IE3 Çıkış Devri	IE3 Çıkış Momenti	Çevrim Oranı	IE3 Güv. Rad. Yük Çıkış	IE3 Servis Faktörü	Tipi	Anma Akımı	Ağırlık	Ölçü Sayfası	Motor Verim Snf.*	
Power	Output Speeds	Output Torque	Ratio	Per.O. Loads (Output)	Service Factors	Type	Rated Current	Weight	Dim. Page	Motor Eff. Class	
Leistung P <sub>g</sub> [kW] P <sub>g</sub> [HP]	Abtriebswelle Drehzahlen n <sub>2</sub> [r.p.m]	Abtriebswelle Drehmomente M <sub>2</sub> [Nm]	Übersetzung i	Zul.Querkräfte (Abtrieb) F <sub>qam</sub> [N]	Betriebsfaktor f <sub>s</sub>	Typ	Nennstrom [A]	Gewicht ~ [kg]	Maße Seite	Motor Effizienz-klasse	
0,75 1,0	15	444	96,68	12098	1,0	KR273-3E80M/4D	1,77	38	98	IE3	
	17	384	83,48	12459	1,2	KR273-2E80M/4C	1,89	36		IE2	
	20	336	72,92	12738	1,3						
	21	315	68,40	12851	1,4						
	25	268	58,15	13094	1,7						
	29	233	50,51	13261	1,9						
	33	204	44,20	13392	2,2						
	40	169	36,55	13541	2,7						
	48	141	30,48	13653	3,2						
	57	118	25,55	13799	3,6						
	63	107	23,08	13908	3,8						
	76	89	19,08	14143	4,0						
		20	334	72,37	5471	0,8	KR203-3E80M/4D	1,77	34	94	IE3
		23	292	63,33	5739	1,0	KR203-2E80M/4C	1,89	33		IE2
		28	242	52,37	5719	1,2					
		33	202	43,67	5643	1,4					
38		177	38,16	5559	1,6						
46		146	31,55	5408	1,9						
55		122	26,31	5239	2,2						
	61	111	23,79	6507	2,5	KR202-3E80M/4D	1,77	34	94	IE3	
	72	95	20,23	6133	3,0	KR202-2E80M/4C	1,89	33		IE2	
	83	82	17,47	5815	3,3						
	41	163	35,22	4667	0,8	KR103-3E80M/4D	1,77	21	90	IE3	
	44	152	32,90	4646	0,9	KR103-2E80M/4C	1,89	20		IE2	
	52	128	27,81	4574	1,0						
	57	119	25,50	6298	1,0	KR102-3E80M/4D	1,77	21	90	IE3	
	68	99	21,25	5884	1,2	KR102-2E80M/4C	1,89	20		IE2	
	76	90	19,13	5658	1,2						
	84	81	17,30	5452	1,4						
	99	69	14,61	5123	1,6						
	116	59	12,51	4841	1,8						
	131	52	11,05	4626	1,9						
	140	49	10,32	4513	2,1						
	166	41	8,72	4247	2,3						
	199	34	7,29	3981	2,6						
	231	30	6,28	3776	3,0						
	261	26	11,05	3616	3,3	KR102-3E80M/2B	1,59	21	90	IE3	
	279	24	10,32	3530	3,3	KR102-2E80M/2A	1,67	20		IE2	
	73	93	19,88	2961	0,9	KR002-3E80M/4D	1,77	20	86	IE3	
	90	76	16,18	2941	1,0	KR002-2E80M/4C	1,89	19		IE2	
	98	69	14,73	2920	1,1						
	109	62	13,26	2890	1,2						
	131	52	11,09	2822	1,4						
	154	44	9,40	2747	1,6						
	180	38	8,04	2669	1,7						
	194	35	7,46	2630	1,9						
	217	31	13,26	2573	1,9	KR002-3E80M/2B	1,59	18	86	IE3	
	260	26	11,09	2471	2,3	KR002-2E80M/2A	1,67	17		IE2	
	307	22	9,40	2375	2,5						
	358	19	8,04	2284	2,9						
	386	18	7,46	2240	3,1						

\*: IE2 ve IE3 motorlu redüktör fiyatları farklıdır. / Geared motor prices are different for IE2 and IE3 motors. / Preise von Getrieben mit IE2 und IE3 Motoren sind unterschiedlich.

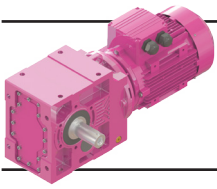

# K Serisi Motorlu Güç Devir Sayfaları

## K Series Geared Motors Performance Tables

### K Serien Getriebemotoren Leistung und Drehzahlübersicht

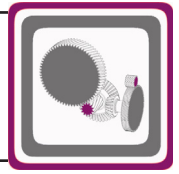

Güç	IE3 Çıkış Devri	IE3 Çıkış Momenti	Çevrim Oranı	IE3 Güv. Rad. Yük Çıkış	IE3 Servis Faktörü	Tipi	Anma Akımı	Ağırlık	Ölçü Sayfası	Motor Verim Sınıfı*
Power	Output Speeds	Output Torque	Ratio	Per. O. Loads (Output)	Service Factors	Type	Rated Current	Weight	Dim. Page	Motor Eff. Class
Leistung P <sub>g</sub> [kW] P <sub>g</sub> [HP]	Abtriebswelle Drehzahlen n <sub>2</sub> [r.p.m]	Abtriebswelle Drehmomente M <sub>2</sub> [Nm]	Übersetzung i	Zul.Querkräfte (Abtrieb) F <sub>qam</sub> [N]	Betriebsfaktor f <sub>s</sub>	Typ	Nennstrom [A]	Gewicht ~ [kg]	Maße Seite	Motor Effizienz-klasse
1,1 1,5	0,77	12168	<b>1891,08</b>	95780	1,2	<b>KR875-3E90S/4C</b>	2,46	657	174	IE3
	0,87	10771	<b>1671,18</b>	101381	1,4	<b>KR875-2E90S/4B</b>	2,60	655		IE2
	0,97	9639	<b>1495,27</b>	105337	1,6					
	1,1	8479	<b>1313,07</b>	109373	1,8					
	1,3	7099	<b>1096,71</b>	113443	2,1					
	1,5	6204	<b>957,34</b>	115988	2,4					
	1,7	5478	<b>844,51</b>	117936	2,7					
	1,9	4878	<b>751,30</b>	119473	3,1					
0,94 1,1 1,2 1,4 1,5 1,7 1,9 2,2	0,94	9946	<b>1547,01</b>	40762	0,8	<b>KR775-3E90S/4C</b>	2,46	399	162	IE3
	1,1	8706	<b>1353,02</b>	50450	0,9	<b>KR775-2E90S/4B</b>	2,60	397		IE2
	1,2	7681	<b>1192,77</b>	56568	1,0					
	1,4	6819	<b>1058,16</b>	61043	1,2					
	1,5	6083	<b>943,49</b>	64432	1,3					
	1,7	5385	<b>833,78</b>	67228	1,5					
	1,9	4820	<b>746,01</b>	69510	1,7					
	2,2	4241	<b>655,11</b>	71469	1,9					
2,4 2,7 3,0 3,4	2,4	4057	<b>396,00</b>	72289	2,0	<b>KR774-3E90L/6C</b>	2,75	348	158	IE3
	2,7	3631	<b>354,32</b>	73579	2,2	<b>KR774-2E90L/6B</b>	2,90	345		IE2
	3,0	3194	<b>311,14</b>	74922	2,5					
	3,4	2860	<b>278,35</b>	75898	2,8					
3,7 4,1	3,7	2630	<b>396,00</b>	76498	3,0	<b>KR774-3E90S/4C</b>	2,46	370	158	IE3
	4,1	2354	<b>354,32</b>	77259	3,4	<b>KR774-2E90S/4B</b>	2,60	368		IE2
1,8 2,0 2,3	1,8	5208	<b>809,27</b>	16646	0,8	<b>KR675-3E90S/4C</b>	2,46	257	150	IE3
	2,0	4662	<b>724,08</b>	24408	0,9	<b>KR675-2E90S/4B</b>	2,60	255		IE2
	2,3	4101	<b>635,86</b>	30274	1,0					
2,6 2,9 3,4	2,6	3714	<b>363,81</b>	33437	1,2	<b>KR674-3E90L/6C</b>	2,75	271	146	IE3
	2,9	3287	<b>321,51</b>	36489	1,3	<b>KR674-2E90L/6B</b>	2,90	268		IE2
	3,4	2797	<b>273,88</b>	39532	1,5					
4,0 4,5 5,3 6,2 7,1	4,0	2407	<b>363,81</b>	41618	1,8	<b>KR674-3E90S/4C</b>	2,46	270	146	IE3
	4,5	2131	<b>321,51</b>	42965	2,0	<b>KR674-2E90S/4B</b>	2,60	268		IE2
	5,3	1813	<b>273,88</b>	44444	2,4					
	6,2	1561	<b>235,44</b>	45531	2,8					
	7,1	1357	<b>204,32</b>	46361	3,2					
3,1 3,7 4,4 5,2 5,9 6,1 6,9 8,0 9,1 10 12	3,1	3085	<b>469,74</b>	18048	0,9	<b>KR574-3E90S/4C</b>	2,46	159	134	IE3
	3,7	2611	<b>397,01</b>	23598	1,0	<b>KR574-2E90S/4B</b>	2,60	157		IE2
	4,4	2166	<b>328,56</b>	27343	1,2					
	5,2	1854	<b>281,00</b>	29553	1,5					
	5,9	1629	<b>246,42</b>	30921	1,7					
	6,1	1571	<b>237,97</b>	31286	1,7					
	6,9	1397	<b>211,51</b>	32230	1,9					
	8,0	1196	<b>180,90</b>	33290	2,3					
	9,1	1051	<b>158,64</b>	34002	2,6					
	10	931	<b>140,24</b>	34561	2,9					
	12	785	<b>117,96</b>	35203	3,4					
	6,1 6,9 8,5	6,1	1594	<b>153,47</b>	16176	1,0	<b>KR473-3E90L/6C</b>	2,75	102	118
6,9		1412	<b>135,98</b>	17815	1,1	<b>KR473-2E90L/6B</b>	2,90	99		IE2
8,5		1151	<b>110,65</b>	19787	1,3					
9,4	9,4	1036	<b>153,47</b>	20546	1,5	<b>KR473-3E90S/4C</b>	2,46	101	118	IE3
						<b>KR473-2E90S/4B</b>	2,60	99		IE2

\*: IE2 ve IE3 motorlu redüktör fiyatları farklıdır. / Geared motor prices are different for IE2 and IE3 motors. / Preise von Getrieben mit IE2 und IE3 Motoren sind unterschiedlich.



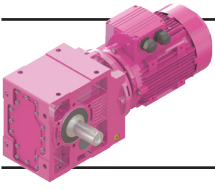

# K Serisi Motorlu Güç Devir Sayfaları

## K Series Geared Motors Performance Tables

### K Serien Getriebemotoren Leistung und Drehzahlübersicht

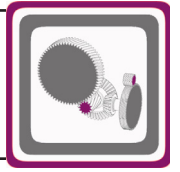

Güç	IE3 Çıkış Devri	IE3 Çıkış Momenti	Çevrim Oranı	IE3 Güv. Rad. Yük Çıkış	IE3 Servis Faktörü	Tipi	Anma Akımı	Ağırlık	Ölçü Sayfası	Motor Verim Snf.*	
Power	Output Speeds	Output Torque	Ratio	Per.O. Loads (Output)	Service Factors	Type	Rated Current	Weight	Dim. Page	Motor Eff. Class	
Leistung P <sub>g</sub> [kW] P <sub>g</sub> [HP]	Abtriebswelle Drehzahlen n <sub>2</sub> [r.p.m]	Abtriebswelle Drehmomente M <sub>2</sub> [Nm]	Übersetzung i	Zul.Querkräfte (Abtrieb) F <sub>qam</sub> [N]	Betriebsfaktor f <sub>s</sub>	Typ	Nennstrom [A]	Gewicht ~ [kg]	Maße Seite	Motor Effizienz-klasse	
1,1 1,5	11	918	<b>135,98</b>	21262	1,7	<b>KR473-3E90S/4C</b>	2,46	101	118	IE3	
	13	748	<b>110,65</b>	22168	2,1	<b>KR473-2E90S/4B</b>	2,60	99		IE2	
	15	662	<b>97,79</b>	22607	2,3						
	17	592	<b>87,49</b>	22944	2,6						
	19	521	<b>76,83</b>	23291	3,0						
	23	436	<b>64,17</b>	23647	3,6						
8,5 9,7 12	8,5	1148	<b>110,61</b>	6284	0,7	<b>KR373-3E90L/6C</b>	2,75	70	106	IE3	
	9,7	1011	<b>97,26</b>	9290	0,8	<b>KR373-2E90L/6B</b>	2,90	67		IE2	
	12	814	<b>78,29</b>	12120	1,0						
13 15 19 21 24 28 33 39	13	746	<b>110,61</b>	12896	1,1	<b>KR373-3E90S/4C</b>	2,46	70	106	IE3	
	15	657	<b>97,26</b>	13804	1,2	<b>KR373-2E90S/4B</b>	2,60	68		IE2	
	19	529	<b>78,29</b>	14925	1,5						
	21	465	<b>68,65</b>	15401	1,8						
	24	411	<b>60,69</b>	15789	2,0						
	28	346	<b>51,05</b>	16226	2,4						
	33	295	<b>43,40</b>	16549	2,8						
	39	253	<b>37,19</b>	16797	3,2						
	17 20 21 25 29 33 40 48 57 63 76 91 109 121 146 175 209	17	564	<b>83,48</b>	11227	0,8	<b>KR273-3E90S/4C</b>	2,46	43	98	IE3
		20	493	<b>72,92</b>	11753	0,9	<b>KR273-2E90S/4B</b>	2,60	41		IE2
21		463	<b>68,40</b>	11975	1,0						
25		393	<b>58,15</b>	12402	1,1						
29		342	<b>50,51</b>	12703	1,3						
33		300	<b>44,20</b>	12933	1,5						
40		248	<b>36,55</b>	13190	1,8						
48		207	<b>30,48</b>	13378	2,2						
57		174	<b>25,55</b>	13602	2,5						
63		158	<b>23,08</b>	13741	2,6						
76		131	<b>19,08</b>	13910	3,0						
91		109	<b>15,92</b>	14034	3,4						
109		92	<b>13,34</b>	14147	3,8						
121		82	<b>12,00</b>	14158	3,1						
146	68	<b>9,92</b>	13462	3,5							
175	57	<b>8,28</b>	12819	4,0							
209	48	<b>6,94</b>	12216	4,0							
28 33 38 46 55	28	355	<b>52,37</b>	4248	0,8	<b>KR203-3E90S/4C</b>	2,46	39	94	IE3	
	33	297	<b>43,67</b>	4663	0,9	<b>KR203-2E90S/4B</b>	2,60	37		IE2	
	38	259	<b>38,16</b>	4718	1,1						
	46	215	<b>31,55</b>	4726	1,3						
	55	179	<b>26,31</b>	4680	1,5						
61 72 83 95 101 119 137	61	163	<b>23,79</b>	6646	1,7	<b>KR202-3E90S/4C</b>	2,46	38	94	IE3	
	72	139	<b>20,23</b>	6258	2,0	<b>KR202-2E90S/4B</b>	2,60	36		IE2	
	83	120	<b>17,47</b>	5927	2,2						
	95	105	<b>15,26</b>	5639	2,5						
	101	99	<b>14,32</b>	5508	2,6						
	119	84	<b>12,17</b>	5189	2,9						
	137	73	<b>10,57</b>	4930	3,2						
64 75	64	155	<b>14,61</b>	5374	0,8	<b>KR102-3E90L/6C</b>	2,75	29	90	IE3	
	75	133	<b>12,51</b>	5814	0,9	<b>KR102-2E90L/6B</b>	2,90	26		IE2	
84 99 116	84	119	<b>17,30</b>	5580	0,9	<b>KR102-3E90S/4C</b>	2,46	25	90	IE3	
	99	101	<b>14,61</b>	5236	1,1	<b>KR102-2E90S/4B</b>	2,60	23		IE2	
	116	86	<b>12,51</b>	4942	1,2						

\*: IE2 ve IE3 motorlu redüktör fiyatları farklıdır. / Geared motor prices are different for IE2 and IE3 motors. / Preise von Getrieben mit IE2 und IE3 Motoren sind unterschiedlich.

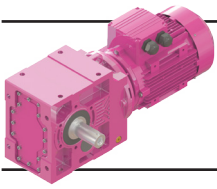

# K Serisi Motorlu Güç Devir Sayfaları

## K Series Geared Motors Performance Tables

### K Serien Getriebemotoren Leistung und Drehzahlübersicht

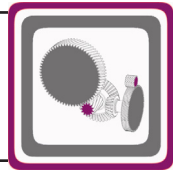

Güç	IE3 Çıkış Devri	IE3 Çıkış Momenti	Çevrim Oranı	IE3 Güv. Rad. Yük Çıkış	IE3 Servis Faktörü	Tipi	Anma Akımı	Ağırlık	Ölçü Sayfası	Motor Verim Snf.*	
Power	Output Speeds	Output Torque	Ratio	Per. O. Loads (Output)	Service Factors	Type	Rated Current	Weight	Dim. Page	Motor Eff. Class	
Leistung P <sub>g</sub> [kW] P <sub>g</sub> [HP]	Abtriebswelle Drehzahlen n <sub>2</sub> [r.p.m]	Abtriebswelle Drehmomente M <sub>2</sub> [Nm]	Übersetzung i	Zul.Querkräfte (Abtrieb) F <sub>qam</sub> [N]	Betriebsfaktor f <sub>s</sub>	Typ	Nennstrom [A]	Gewicht ~ [kg]	Maße Seite	Motor Effizienz-klasse	
1,1 1,5	131	76	11,05	4719	1,3	KR102-3E90S/4C	2,46	25	90	IE3	
	140	71	10,32	4601	1,4	KR102-2E90S/4B	2,60	23		IE2	
	166	60	8,72	4324	1,6						
	199	50	7,29	4047	1,8						
	231	43	6,28	3834	2,1						
		261	38	11,05	3668	2,2	KR102-3E80M/2C	2,26	21	90	IE3
		279	36	10,32	3579	2,2	KR102-2E80M/2B	2,36	19		IE2
		330	30	8,72	3369	2,6					
		395	25	7,29	3159	3,0					
		458	22	6,28	2997	3,2					
		109	91	13,26	2421	0,8	KR002-3E90S/4C	2,46	25	86	IE3
		131	76	11,09	2439	1,0	KR002-2E90S/4B	2,60	23		IE2
		154	65	9,40	2428	1,1					
		180	56	8,04	2400	1,2					
		194	52	7,46	2382	1,3					
	217	46	13,26	2353	1,3	KR002-3E80M/2C	2,26	20	86	IE3	
	260	38	11,09	2290	1,6	KR002-2E80M/2B	2,36	18		IE2	
	307	33	9,40	2223	1,7						
	358	28	8,04	2155	2,0						
	386	26	7,46	2121	2,1						
1,5 2,0	0,97	13144	1495,27	91475	1,1	KR875-3E90L/4D	3,30	659	174	IE3	
	1,1	11563	1313,07	98281	1,3	KR875-2E90L/4C	3,40	658		IE2	
	1,3	9680	1096,71	100689	1,5						
	1,5	8460	957,34	104678	1,8						
	1,7	7470	844,51	107455	2,0						
	1,9	6652	751,30	109747	2,3						
		2,2	6023	438,70	111593	2,5	KR874-3E100L/6B	3,50	895	170	IE3
		2,5	5282	383,99	113316	2,8	KR874-2E100L/6A	3,72	892		IE2
		2,8	4681	339,70	114765	3,2					
		1,4	9298	1058,16	46159	0,9	KR775-3E90L/4D	3,30	428	162	IE3
		1,5	8295	943,49	52976	1,0	KR775-2E90L/4C	3,40	427		IE2
		1,7	7344	833,78	58389	1,1					
		1,9	6573	746,01	62215	1,2					
		2,2	5783	655,11	65720	1,4					
		2,4	5445	396,00	66988	1,5	KR774-3E100L/6B	3,50	414	158	IE3
		2,7	4873	354,32	69216	1,6	KR774-2E100L/6A	3,72	411		IE2
		3,1	4287	311,14	71333	1,9					
		3,4	3839	278,35	72930	2,1					
		3,7	3586	396,00	73641	2,2	KR774-3E90L/4D	3,30	410	158	IE3
		4,1	3210	354,32	74809	2,5	KR774-2E90L/4C	3,40	409		IE2
		4,7	2823	311,14	75948	2,8					
		5,2	2529	278,35	76780	3,2					
		6,0	2184	240,71	77712	3,7					
		2,6	4984	363,81	20305	0,9	KR674-3E100L/6B	3,50	308	146	IE3
		3,0	4412	321,51	27178	1,0	KR674-2E100L/6A	3,72	305		IE2

\*: IE2 ve IE3 motorlu redüktör fiyatları farklıdır. / Geared motor prices are different for IE2 and IE3 motors. / Preise von Getrieben mit IE2 und IE3 Motoren sind unterschiedlich.

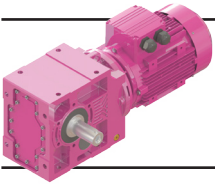

# K Serisi Motorlu Güç Devir Sayfaları

## K Series Geared Motors Performance Tables

### K Serien Getriebemotoren Leistung und Drehzahlübersicht

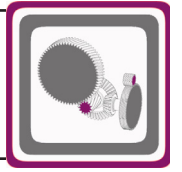

Güç	IE3 Çıkış Devri	IE3 Çıkış Momenti	Çevrim Oranı	IE3 Güv. Rad. Yük Çıkış	IE3 Servis Faktörü	Tipi	Anma Akımı	Ağırlık	Ölçü Sayfası	Motor Verim Snf.*
Power	Output Speeds	Output Torque	Ratio	Per.O. Loads (Output)	Service Factors	Type	Rated Current	Weight	Dim. Page	Motor Eff. Class
Leistung P <sub>g</sub> [kW] P <sub>g</sub> [HP]	Abtriebswelle Drehzahlen n <sub>2</sub> [r.p.m]	Abtriebswelle Drehmomente M <sub>2</sub> [Nm]	Übersetzung i	Zul.Querkräfte (Abtrieb) F <sub>qam</sub> [N]	Betriebsfaktor f <sub>s</sub>	Typ	Nennstrom [A]	Gewicht ~ [kg]	Maße Seite	Motor Effizienz-klasse
1,5 2,0	3,5	3754	273,88	33125	1,1	KR674-3E100L/6B KR674-2E100L/6A	3,50 3,72	308 305	146	IE3 IE2
	4,0 4,5 5,3 6,2 7,1 8,1 9,2	3283 2906 2472 2129 1850 1619 1425	363,81 321,51 273,88 235,44 204,32 178,62 157,02	36521 38894 41257 42977 44279 45286 46088	1,3 1,5 1,7 2,0 2,3 2,7 3,0	KR674-3E90L/4D KR674-2E90L/4C	3,30 3,40	303 302	146	IE3 IE2
	4,4 5,2 5,9 6,1 6,9	2954 2528 2221 2142 1906	328,56 281,00 246,42 237,97 211,51	19787 24321 26922 27526 29208	0,9 1,1 1,2 1,3 1,4	KR574-3E90L/4D KR574-2E90L/4C	3,30 3,40	163 162	134	IE3 IE2
	7,6 8,7 9,8 12 14 16	1751 1534 1359 1150 943 834	125,51 109,86 97,19 82,14 67,37 59,49	30219 31473 32492 33561 34510 34996	1,5 1,8 2,0 2,3 2,9 3,2	KR573-3E100L/6B KR573-2E100L/6A	3,50 3,72	155 152	130	IE3 IE2
	8,6	1545	110,65	16645	1,0	KR473-3E100L/6B KR473-2E100L/6A	3,50 3,72	109 106	118	IE3 IE2
	9,4 11 13 15 17 19 23 24	1414 1252 1021 903 808 711 595 562	153,47 135,98 110,65 97,79 87,49 76,83 64,17 60,63	17802 19067 20637 21344 21845 22362 22934 23086	1,1 1,2 1,5 1,7 1,9 2,2 2,6 2,8	KR473-3E90L/4D KR473-2E90L/4C	3,30 3,40	103 102	118	IE3 IE2
	13 15 19 21 24 28 33 39 43	1019 897 722 634 561 473 402 345 313	110,61 97,26 78,29 68,65 60,69 51,05 43,40 37,19 33,65	9109 11080 13151 13994 14661 15340 15850 16233 16440	0,8 0,9 1,1 1,3 1,5 1,7 2,0 2,4 2,6	KR373-3E90L/4D KR373-2E90L/4C	3,30 3,40	72 71	106	IE3 IE2
	25 29 33 40 48 57 63 76 91 109 121 146 175 209	537 467 409 339 283 237 215 178 149 125 112 93 77 65	58,15 50,51 44,20 36,55 30,48 25,55 23,08 19,08 15,92 13,34 12,00 9,92 8,28 6,94	11437 11945 12305 12722 13019 13332 13515 13742 13907 14050 13884 13235 12630 12057	0,8 1,0 1,1 1,3 1,6 1,8 1,9 2,2 2,5 2,8 2,2 2,6 3,0 3,4	KR273-3E90L/4D KR273-2E90L/4C	3,30 3,40	45 44	98	IE3 IE2

\*: IE2 ve IE3 motorlu redüktör fiyatları farklıdır. / Geared motor prices are different for IE2 and IE3 motors. / Preise von Getrieben mit IE2 und IE3 Motoren sind unterschiedlich.

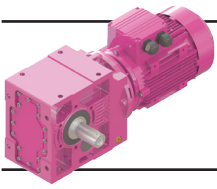

# K Serisi Motorlu Güç Devir Sayfaları

## K Series Geared Motors Performance Tables

### K Serien Getriebemotoren Leistung und Drehzahlübersicht

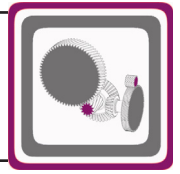

Güç	IE3 Çıkış Devri	IE3 Çıkış Momenti	Çevrim Oranı	IE3 Güv. Rad. Yük Çıkış	IE3 Servis Faktörü	Tipi	Anma Akımı	Ağırlık	Ölçü Sayfası	Motor Verim Snf.*
Power	Output Speeds	Output Torque	Ratio	Per. O. Loads (Output)	Service Factors	Type	Rated Current	Weight	Dim. Page	Motor Eff. Class
Leistung P <sub>g</sub> [kW] P <sub>g</sub> [HP]	Abtriebswelle Drehzahlen n <sub>2</sub> [r.p.m]	Abtriebswelle Drehmomente M <sub>2</sub> [Nm]	Übersetzung i	Zul.Querkräfte (Abtrieb) F <sub>qam</sub> [N]	Betriebsfaktor f <sub>s</sub>	Typ	Nennstrom [A]	Gewicht ~ [kg]	Maße Seite	Motor Effizienz-klasse
1,5 2,0	38	354	38,16	3679	0,8	KR203-3E90L/4D	3,30	41	94	IE3
	46	293	31,55	3892	1,0	KR203-2E90L/4C	3,40	40		IE2
	55	245	26,31	4001	1,1					
	61	223	23,79	6772	1,3	KR202-3E90L/4D	3,30	40	94	IE3
	72	190	20,23	6376	1,5	KR202-2E90L/4C	3,40	39		IE2
	83	164	17,47	6036	1,6					
	95	144	15,26	5739	1,8					
	101	135	14,32	5604	1,9					
	119	115	12,17	5276	2,1					
	137	100	10,57	5007	2,4					
	157	87	9,25	4767	2,6					
	190	72	7,65	4446	3,0					
	227	60	6,38	4162	3,4					
	99	137	14,61	5343	0,8	KR102-3E90L/4D	3,30	27	90	IE3
	116	118	12,51	5040	0,9	KR102-2E90L/4C	3,40	26		IE2
	131	104	11,05	4810	1,0					
	140	97	10,32	4688	1,0					
	166	82	8,72	4401	1,2					
199	69	7,29	4115	1,3						
231	59	6,28	3895	1,5						
262	52	11,05	3714	1,6	KR102-3E90S/2B	2,97	25	90	IE3	
281	48	10,32	3622	1,6	KR102-2E90S/2A	3,19	23		IE2	
332	41	8,72	3405	2,0						
398	34	7,29	3189	2,2						
462	30	6,28	3023	2,4						
154	88	9,40	2037	0,8	KR002-3E90L/4D	3,30	26	86	IE3	
180	76	8,04	2072	0,9	KR002-2E90L/4C	3,40	25		IE2	
194	70	7,46	2080	0,9						
309	44	9,40	2042	1,2	KR002-3E90S/2B	2,97	24	86	IE3	
361	38	8,04	2002	1,5	KR002-2E90S/2A	3,19	22		IE2	
389	35	7,46	1980	1,6						
2,2 3,0	1,5	12408	957,34	90454	1,2	KR875-3E100L/4C	4,65	688	174	IE3
	1,7	10956	844,51	96153	1,4	KR875-2E100L/4B	4,85	686		IE2
	1,9	9756	751,30	100520	1,5					
	2,2	8746	673,01	103816	1,7					
	2,5	7667	383,99	106918	2,0	KR874-3E112M/6B	4,95	678	170	IE3
	2,8	6794	339,70	109386	2,2	KR874-2E112M/6A	5,32	675		IE2
	3,3	5818	438,70	111999	2,6	KR874-3E100L/4C	4,65	697	170	IE3
	3,8	5103	383,99	113778	2,9	KR874-2E100L/4B	4,85	695		IE2
	4,3	4522	339,70	115157	3,3					
	5,1	3831	287,10	116725	3,9					
	6,2	3145	235,47	122868	4,0					
	1,9	9640	746,01	43697	0,8	KR775-3E100L/4C	4,65	410	162	IE3
	2,2	8482	655,11	51811	0,9	KR775-2E100L/4B	4,85	408		IE2
	2,4	7903	396,00	55312	1,0	KR774-3E112M/6B	4,95	387	158	IE3
	2,7	7073	354,32	59782	1,1	KR774-2E112M/6A	5,32	3843		IE2

\*: IE2 ve IE3 motorlu redüktör fiyatları farklıdır. / Geared motor prices are different for IE2 and IE3 motors. / Preise von Getrieben mit IE2 und IE3 Motoren sind unterschiedlich.

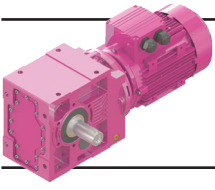

# K Serisi Motorlu Güç Devir Sayfaları

## K Series Geared Motors Performance Tables

### K Serien Getriebemotoren Leistung und Drehzahlübersicht

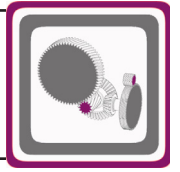

Güç	IE3 Çıkış Devri	IE3 Çıkış Momenti	Çevrim Oranı	IE3 Güv. Rad. Yük Çıkış	IE3 Servis Faktörü	Tipi	Anma Akımı	Ağırlık	Ölçü Sayfası	Motor Verim Snf.*	
Power	Output Speeds	Output Torque	Ratio	Per.O. Loads (Output)	Service Factors	Type	Rated Current	Weight	Dim. Page	Motor Eff. Class	
Leistung P <sub>g</sub> [kW] P <sub>g</sub> [HP]	Abtriebswelle Drehzahlen n <sub>2</sub> [r.p.m]	Abtriebswelle Drehmomente M <sub>2</sub> [Nm]	Übersetzung i	Zul.Querkräfte (Abtrieb) F <sub>qam</sub> [N]	Betriebsfaktor f <sub>s</sub>	Typ	Nennstrom [A]	Gewicht ~ [kg]	Maße Seite	Motor Effizienz-klasse	
2,2 3,0	3,1	6222	311,14	63818	1,3	KR774-3E112M/6B	4,95	387	158	IE3	
	3,5	5573	278,35	66590	1,4	KR774-2E112M/6A	5,32	384		IE2	
	3,7	5260	396,00	67765	1,5	KR774-3E100L/4C	4,65	383	158	IE3	
	4,1	4707	354,32	69865	1,7	KR774-2E100L/4B	4,85	381		IE2	
	4,7	4141	311,14	71861	1,9						
	5,2	3709	278,35	73290	2,2						
	6,0	3203	240,71	74861	2,5						
	7,0	2778	208,42	76105	2,9						
	8,0	2433	182,29	77065	3,3						
		8,0	2433	182,29	77065	3,3					
	4,0	4815	363,81	22700	0,9	KR674-3E100L/4C	4,65	280	146	IE3	
	4,5	4262	321,51	28741	1,0	KR674-2E100L/4B	4,85	278		IE2	
	5,3	3626	273,88	34100	1,2						
	6,2	3122	235,44	37497	1,4						
	7,1	2713	204,32	39957	1,6						
	7,5	2612	128,24	40492	1,6	KR673-3E112M/6B	4,95	228	142	IE3	
	9,6	2057	100,90	43338	2,1	KR673-2E112M/6A	5,32	225		IE2	
	11	1841	90,21	44333	2,3						
	11	1744	128,24	44776	2,5	KR673-3E100L/4C	4,65	323	142	IE3	
	14	1373	100,90	46314	3,1	KR673-2E100L/4B	4,85	321		IE2	
	16	1229	90,21	46873	3,5						
	5,9	3257	246,42	15565	0,8	KR574-3E100L/4C	4,65	171	134	IE3	
	6,1	3142	237,97	17405	0,9	KR574-2E100L/4B	4,85	169		IE2	
	6,9	2795	211,51	21659	1,0						
	8,0	2392	180,90	25521	1,1						
	8,8	2230	109,86	26853	1,2	KR573-3E112M/6B	4,95	159	130	IE3	
	9,9	1975	97,19	28736	1,4	KR573-2E112M/6A	5,32	156		IE2	
	12	1698	125,51	30509	1,6	KR573-3E100L/4C	4,65	156	130	IE3	
	13	1488	109,86	31752	1,8	KR573-2E100L/4B	4,85	154		IE2	
	15	1318	97,19	32683	2,0						
	18	1116	82,14	33708	2,4						
	22	916	67,37	34643	2,9						
	24	809	59,49	35108	3,3						
		12	1698	125,51	30509	1,6	KR573-3E100L/4C	4,65	156	130	IE3
		13	1488	109,86	31752	1,8	KR573-2E100L/4B	4,85	154		IE2
	13	1498	110,65	17069	1,0	KR473-3E100L/4C	4,65	111	118	IE3	
	15	1326	97,79	18493	1,2	KR473-2E100L/4B	4,85	109		IE2	
	17	1186	87,49	19515	1,3						
	19	1043	76,83	20477	1,5						
	23	872	64,17	21504	1,8						
	24	825	60,63	21771	1,9						
	24	804	59,19	21883	1,9						
	28	697	51,22	22444	2,2						
	32	608	44,64	22879	2,5						
	37	533	39,11	23212	2,9						
	48	413	30,11	23753	3,8						
		19	1060	78,29	8376	0,8	KR373-3E100L/4C	4,65	82	106	IE3
21		931	68,65	10572	0,9	KR373-2E100L/4B	4,85	80		IE2	
24		824	60,69	12006	1,0						
28		694	51,05	13419	1,2						

\*: IE2 ve IE3 motorlu redüktör fiyatları farklıdır. / Geared motor prices are different for IE2 and IE3 motors. / Preise von Getrieben mit IE2 und IE3 Motoren sind unterschiedlich.

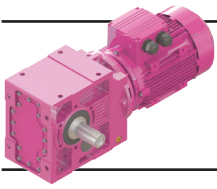

# K Serisi Motorlu Güç Devir Sayfaları

## K Series Geared Motors Performance Tables

### K Serien Getriebemotoren Leistung und Drehzahlübersicht

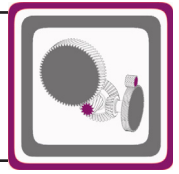

Güç	IE3 Çıkış Devri	IE3 Çıkış Momenti	Çevrim Oranı	IE3 Güv. Rad. Yük Çıkış	IE3 Servis Faktörü	Tipi	Anma Akımı	Ağırlık	Ölçü Sayfası	Motor Verim Snf.*
Power	Output Speeds	Output Torque	Ratio	Per.O. Loads (Output)	Service Factors	Type	Rated Current	Weight	Dim. Page	Motor Eff. Class
Leistung P <sub>g</sub> [kW] P <sub>g</sub> [HP]	Abtriebswelle Drehzahlen n <sub>2</sub> [r.p.m]	Abtriebswelle Drehmomente M <sub>2</sub> [Nm]	Übersetzung i	Zul.Querkräfte (Abtrieb) F <sub>qam</sub> [N]	Betriebsfaktor f <sub>s</sub>	Typ	Nennstrom [A]	Gewicht ~ [kg]	Maße Seite	Motor Effizienz-klasse
2,2 3,0	33	591	43,40	14412	1,4	KR373-3E100L/4C	4,65	82	106	IE3
	39	507	37,19	15090	1,6	KR373-2E100L/4B	4,85	80		IE2
	43	459	33,65	15456	1,8					
	50	393	28,85	15923	2,1					
	59	337	24,72	16292	2,4					
	66	301	21,90	16519	2,7					
	78	256	18,62	16777	3,2					
	33	600	44,20	10904	0,7	KR273-3E100L/4C	4,65	53	98	IE3
	40	497	36,55	11733	0,9	KR273-2E100L/4B	4,85	51		IE2
	48	415	30,48	12275	1,1					
	57	348	25,55	12785	1,2					
	63	316	23,08	13060	1,3					
	76	262	19,08	13409	1,5					
	91	218	15,92	13658	1,7					
	109	183	13,34	13861	1,9					
	121	164	12,00	13403	1,5					
	146	136	9,92	12838	1,8					
	175	114	8,28	12299	2,0					
	209	95	6,94	11780	2,3					
	217	92	13,34	13947	3,3	KR273-3E90L/2C	4,25	46	98	IE3
	242	82	12,00	13403	2,7	KR273-2E90L/2B	4,48	44		IE2
	292	68	9,92	12838	3,1					
	350	57	8,28	12299	3,5					
	418	48	6,94	11780	4,0					
	95	211	15,26	5873	1,2	KR202-3E100L/4C	4,65	47	94	IE3
	101	198	14,32	5735	1,3	KR202-2E100L/4B	4,85	45		IE2
	119	168	12,17	5398	1,5					
	137	146	10,57	5121	1,6					
157	128	9,25	4872	1,8						
190	106	7,65	4539	2,0						
227	89	6,38	4243	2,3						
314	64	9,25	3768	2,9	KR202-3E90L/2C	4,25	40	94	IE3	
379	53	7,65	3516	3,3	KR202-2E90L/2B	4,48	38		IE2	
455	44	6,38	3292	3,7						
3,0 4,0	2,2	11926	673,01	92419	1,3	KR875-3E100L/4D	6,26	670	174	IE3
	2,5	10355	584,66	98329	1,4	KR875-2E100L/4C	6,42	667		IE2
	2,9	9217	339,70	102283	1,6	KR874-3E132S/6B KR874-2E132S/6A	6,55 6,85	699 694	170	IE3 IE2
	3,3	7934	438,70	106177	1,9	KR874-3E100L/4D	6,26	651	170	IE3
	3,8	6958	383,99	108971	2,2	KR874-2E100L/4C	6,42	648		IE2
	4,3	6166	339,70	111100	2,4					
	5,1	5223	287,10	113484	2,9					
	6,2	4289	235,47	115693	3,5					
	7,0	3794	207,95	116805	4,0					
	7,8	3378	184,83	120594	4,0					
	3,1	8441	311,14	52078	0,9	KR774-3E132S/6B	6,55	414	158	IE3
	3,5	7560	278,35	57218	1,1	KR774-2E132S/6A	6,85	409		IE2
	3,7	7172	396,00	59150	1,1	KR774-3E100L/4D	6,26	386	158	IE3
	4,1	6419	354,32	62825	1,2	KR774-2E100L/4C	6,42	383		IE2

\*: IE2 ve IE3 motorlu redüktör fiyatları farklıdır. / Geared motor prices are different for IE2 and IE3 motors. / Preise von Getrieben mit IE2 und IE3 Motoren sind unterschiedlich.

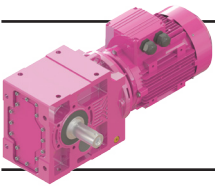

# K Serisi Motorlu Güç Devir Sayfaları

## K Series Geared Motors Performance Tables

### K Serien Getriebemotoren Leistung und Drehzahlübersicht

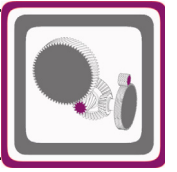

Güç	IE3 Çıkış Devri	IE3 Çıkış Momenti	Çevrim Oranı	IE3 Güv. Rad. Yük Çıkış Per.O. Loads (Output)	IE3 Servis Faktörü	Tipi	Anma Akımı	Ağırlık	Ölçü Sayfası	Motor* Verim Snf.
Power	Output Speeds	Output Torque	Ratio	Per.O. Loads (Output)	Service Factors	Type	Rated Current	Weight	Dim. Page	Motor Eff. Class
Leistung P <sub>g</sub> [kW] P <sub>g</sub> [HP]	Abtriebswelle Drehzahlen n <sub>2</sub> [r.p.m]	Abtriebswelle Drehmomente M <sub>2</sub> [Nm]	Übersetzung i	Zul.Querkräfte (Abtrieb) F <sub>qam</sub> [N]	Betriebsfaktor f <sub>s</sub>	Typ	Nennstrom [A]	Gewicht ~ [kg]	Maße Seite	Motor Effizienz-klasse
3,0 4,0	4,7	5647	311,14	66285	1,4	KR774-3E100L/4D	6,26	386	158	IE3
	5,2	5057	278,35	68627	1,6	KR774-2E100L/4C	6,42	383		IE2
	6,0	4368	240,71	71078	1,8					
	7,0	3789	208,42	73032	2,1					
	8,0	3318	182,29	74513	2,4					
	8,7	3092	111,63	75258	2,6	KR773-3E132S/6B	6,55	396	154	IE3
	9,8	2745	99,00	76225	2,9	KR773-2E132S/6A	6,85	391		IE2
	11	2459	88,57	77020	3,3					
	13	2124	76,59	77906	3,8					
	5,3	4945	273,88	20850	0,9	KR674-3E100L/4D	6,26	281	146	IE3
	6,2	4257	235,44	28787	1,0	KR674-2E100L/4C	6,42	278		IE2
	7,1	3700	204,32	33544	1,2					
	7,6	3541	128,24	34722	1,2	KR673-3E132S/6B	6,55	246	142	IE3
	9,6	2788	100,90	39578	1,5	KR673-2E132S/6A	6,85	241		IE2
	11	2495	90,21	41195	1,7					
	11	2379	128,24	41835	1,8	KR673-3E100L/4D	6,26	223	142	IE3
	14	1874	100,90	44201	2,3	KR673-2E100L/4C	6,42	220		IE2
	16	1677	90,21	45064	2,6					
	18	1496	80,38	45821	2,9					
	8,0	3262	180,90	15479	0,8	KR574-3E100L/4D KR574-2E100L/4C	6,26 6,42	172 169	134	IE3 IE2
	10	2677	97,19	22912	1,0	KR573-3E132S/6B KR573-2E132S/6A	6,55 6,85	192 187	134	IE3 IE2
	12	2317	125,51	26087	1,2	KR573-3E100L/4D	6,26	157	130	IE3
	13	2031	109,86	28341	1,3	KR573-2E100L/4C	6,42	154		IE2
	15	1799	97,19	29906	1,5					
	18	1522	82,14	31557	1,8					
	22	1249	67,37	33041	2,2					
	24	1105	59,49	33763	2,4					
	27	983	52,88	34338	2,7					
	30	895	97,19	34748	3,0	KR573-3E100L/2C	5,58	155	130	IE3
	35	757	82,14	35668	3,4	KR573-2E100L/2B	5,80	152		IE2
	15	1809	97,79	13841	0,9	KR473-3E100L/4D	6,26	113	118	IE3
	17	1618	87,49	15934	1,0	KR473-2E100L/4C	6,42	110		IE2
	19	1423	76,83	17682	1,1					
	23	1190	64,17	19514	1,3					
	24	1125	60,63	19936	1,4					
	24	1097	59,19	20157	1,4					
	28	951	51,22	21047	1,6					
	32	830	44,64	21743	1,9					
	37	728	39,11	22295	2,1					
	48	563	30,11	23068	2,8					
	58	471	25,15	23327	3,3					
	28	947	51,05	10331	0,9	KR373-3E100L/4D	6,26	83	106	IE3
	33	806	43,40	12220	1,0	KR373-2E100L/4C	6,42	80		IE2
	39	691	37,19	13443	1,2					
	43	626	33,65	14092	1,3					
	50	537	28,85	14875	1,5					

\*: IE2 ve IE3 motorlu redüktör fiyatları farklıdır. / Geared motor prices are different for IE2 and IE3 motors. / Preise von Getrieben mit IE2 und IE3 Motoren sind unterschiedlich.

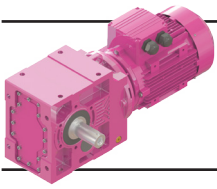

# K Serisi Motorlu Güç Devir Sayfaları

## K Series Geared Motors Performance Tables

### K Serien Getriebemotoren Leistung und Drehzahlübersicht

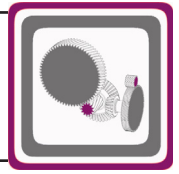

Güç	IE3 Çıkış Devri	IE3 Çıkış Momenti	Çevrim Oranı	IE3 Güv. Rad. Yük Çıkış	IE3 Servis Faktörü	Tipi	Anma Akımı	Ağırlık	Ölçü Sayfası	Motor Verim Snf.*
Power	Output Speeds	Output Torque	Ratio	Per.O. Loads (Output)	Service Factors	Type	Rated Current	Weight	Dim. Page	Motor Eff. Class
Leistung P <sub>g</sub> [kW] P <sub>g</sub> [HP]	Abtriebswelle Drehzahlen n <sub>2</sub> [r.p.m]	Abtriebswelle Drehmomente M <sub>2</sub> [Nm]	Übersetzung i	Zul.Querkräfte (Abtrieb) F <sub>qam</sub> [N]	Betriebsfaktor f <sub>s</sub>	Typ	Nennstrom [A]	Gewicht ~ [kg]	Maße Seite	Motor Effizienz- klasse
3,0 4,0	59	460	24,72	15446	1,8	KR373-3E100L/4D	6,26	83	106	IE3
	66	411	21,90	15803	2,0	KR373-2E100L/4C	6,42	80		IE2
	78	350	18,62	16219	2,3					
	91	300	15,96	16528	2,7					
	100	272	14,44	16687	3,0					
	48	566	30,48	11203	0,8	KR273-3E100L/4D	6,26	55	98	IE3
	57	475	25,55	12026	0,9	KR273-2E100L/4C	6,42	52		IE2
	63	431	23,08	12426	1,0					
	76	357	19,08	12947	1,1					
	91	298	15,92	13328	1,2					
	109	250	13,34	13420	1,4					
	121	224	12,00	12855	1,1					
	146	186	9,92	12384	1,3					
	175	155	8,28	11920	1,5					
	209	130	6,94	11462	1,7					
	218	125	13,34	13420	2,4	KR273-3E100L/2C	5,58	51	98	IE3
	243	112	12,00	12855	2,0	KR273-2E100L/2B	5,80	48		IE2
	294	92	9,92	12384	2,3					
	352	77	8,28	11920	2,6					
	420	65	6,94	11462	2,9					
	95	288	15,26	5955	0,9	KR202-3E100L/4D	6,26	49	94	IE3
	101	270	14,32	5822	0,9	KR202-2E100L/4C	6,42	46		IE2
	119	230	12,17	5491	1,1					
	137	200	10,57	5215	1,2					
	157	175	9,25	4964	1,3					
	190	145	7,65	4625	1,5					
	227	121	6,38	4322	1,7					
	315	87	9,25	3825	2,1	KR202-3E100L/2C	5,58	46	94	IE3
	381	72	7,65	3565	2,4	KR202-2E100L/2B	5,80	43		IE2
	457	60	6,38	3334	2,7					
4,0 5,5	2,8	12068	514,05	92017	1,2	KR875-3E112M/4D	8,05	677	174	IE3
	3,1	10899	463,83	96505	1,4	KR875-2E112M/4C	8,20	675		IE2
	3,8	9214	383,99	102306	1,6	KR874-3E112M/4D	8,05	661	170	IE3
	4,3	8165	339,70	105549	1,8	KR874-2E112M/4C	8,20	659		IE2
	5,1	6917	287,10	109020	2,2					
	6,2	5680	235,47	112301	2,6					
	7,0	5024	207,95	113926	3,0					
	3,7	9497	396,00	44605	0,8	KR774-3E112M/4D	8,05	394	158	IE3
	4,1	8500	354,32	51831	0,9	KR774-2E112M/4C	8,20	392		IE2
	4,7	7478	311,14	57677	1,1					
	5,2	6697	278,35	61629	1,2					
	6,1	5785	240,71	65713	1,4					
	7,0	5017	208,42	68775	1,6					
	8,0	4394	182,29	70935	1,8					
	8,7	4127	111,63	71956	1,9	KR773-3E132M/6C	8,52	408	154	IE3
	9,8	3664	99,00	73471	2,2	KR773-2E132M/6B	8,80	403		IE2
	11	3281	88,57	74615	2,4					
	13	2835	76,59	75970	2,8					
	15	2459	66,32	76931	3,3					
	17	2153	58,00	77814	3,7					

\*: IE2 ve IE3 motorlu redüktör fiyatları farklıdır. / Geared motor prices are different for IE2 and IE3 motors. / Preise von Getrieben mit IE2 und IE3 Motoren sind unterschiedlich.



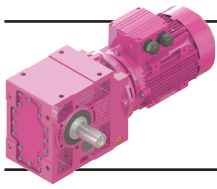

# K Serisi Motorlu Güç Devir Sayfaları

## K Series Geared Motors Performance Tables

### K Serien Getriebemotoren Leistung und Drehzahlübersicht

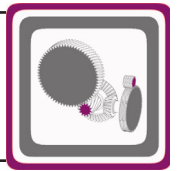

Güç	IE3 Çıkış Devri	IE3 Çıkış Momenti	Çevrim Oranı	IE3 Güv. Rad. Yük Çıkış	IE3 Servis Faktörü	Tipi	Anma Akımı	Ağırlık	Ölçü Sayfası	Motor Verim Snf.*	
Power	Output Speeds	Output Torque	Ratio	Per.O. Loads (Output)	Service Factors	Type	Rated Current	Weight	Dim. Page	Motor Eff. Class	
Leistung P <sub>g</sub> [kW] P <sub>g</sub> [HP]	Abtriebswelle Drehzahlen n <sub>2</sub> [r.p.m]	Abtriebswelle Drehmomente M <sub>2</sub> [Nm]	Übersetzung i	Zul.Querkräfte (Abtrieb) F <sub>qam</sub> [N]	Betriebsfaktor f <sub>s</sub>	Typ	Nennstrom [A]	Gewicht ~ [kg]	Maße Seite	Motor Effizienz-klasse	
4,0 5,5	7,6	4726	<b>128,24</b>	23751	0,9	<b>KR673-3E132M/6C</b>	8,52	239	142	IE3	
	9,6	3721	<b>100,90</b>	33383	1,2	<b>KR673-2E132M/6B</b>	8,80	234		IE2	
	11	3330	<b>90,21</b>	36197	1,3						
	11	3152	<b>128,24</b>	37375	1,4	<b>KR673-3E112M/4D</b>	8,05	234	142	IE3	
	14	2482	<b>100,90</b>	41219	1,7	<b>KR673-2E112M/4C</b>	8,20	232		IE2	
	16	2222	<b>90,21</b>	42596	1,9						
	18	1982	<b>80,38</b>	43675	2,2						
	13	2690	<b>109,86</b>	22797	1,0	<b>KR573-3E112M/4D</b>	8,05	165	130	IE3	
	15	2383	<b>97,19</b>	25605	1,1	<b>KR573-2E112M/4C</b>	8,20	163		IE2	
	18	2017	<b>82,14</b>	28440	1,3						
	22	1655	<b>67,37</b>	30808	1,6						
	25	1463	<b>59,49</b>	31921	1,8						
	28	1302	<b>52,88</b>	32744	2,1						
	33	1103	<b>44,73</b>	34132	2,4						
	38	942	<b>38,16</b>	35377	2,7						
	43	830	<b>67,37</b>	36050	3,0	<b>KR573-3E112M/2C</b>	7,28	161	130	IE3	
	49	734	<b>59,49</b>	36784	3,2	<b>KR573-2E112M/2A</b>	7,50	157		IE2	
	23	1577	<b>64,17</b>	16339	1,0	<b>KR473-3E112M/4D</b>	8,05	121	118	IE3	
	24	1491	<b>60,63</b>	17138	1,0	<b>KR473-2E112M/4C</b>	8,20	119		IE2	
	25	1454	<b>59,19</b>	17463	1,1						
	29	1260	<b>51,22</b>	19013	1,2						
	33	1099	<b>44,64</b>	20136	1,4						
	37	964	<b>39,11</b>	20986	1,6						
	48	746	<b>30,11</b>	22200	2,1						
	58	625	<b>25,15</b>	22635	2,5						
	61	590	<b>23,76</b>	22358	2,6						
	63	576	<b>23,19</b>	22241	2,7						
	73	499	<b>20,07</b>	21532	3,0						
	83	436	<b>17,49</b>	20857	3,3						
		34	1068	<b>43,40</b>	8204	0,8	<b>KR373-3E112M/4D</b>	8,05	90	106	IE3
39		916	<b>37,19</b>	10802	0,9	<b>KR373-2E112M/4C</b>	8,20	88		IE2	
43		830	<b>33,65</b>	11934	1,0						
51		711	<b>28,85</b>	13270	1,2						
59		610	<b>24,72</b>	14241	1,3						
67		544	<b>21,90</b>	14785	1,5						
78		463	<b>18,62</b>	15412	1,8						
92		398	<b>15,96</b>	15882	2,1						
101		360	<b>14,44</b>	16150	2,3						
118		309	<b>12,38</b>	16476	2,7						
138		265	<b>10,60</b>	16163	3,0						
		63	571	<b>23,08</b>	11483	0,7	<b>KR273-3E112M/4D</b>	8,05	63	98	IE3
		77	473	<b>19,08</b>	12297	0,8	<b>KR273-2E112M/4C</b>	8,20	61		IE2
	92	395	<b>15,92</b>	12863	0,9						
	109	332	<b>13,34</b>	12762	1,1						
	122	297	<b>12,00</b>	12168	0,8						
	147	246	<b>9,92</b>	11817	1,0						
	176	206	<b>8,28</b>	11447	1,1						
	210	173	<b>6,94</b>	11066	1,3						
	218	166	<b>13,34</b>	12762	1,8	<b>KR273-3E112M/2C</b>	7,28	58	98	IE3	
	243	149	<b>12,00</b>	12168	1,5	<b>KR273-2E112M/2A</b>	7,50	54		IE2	
	294	124	<b>9,92</b>	11817	1,7						

\*: IE2 ve IE3 motorlu redüktör fiyatları farklıdır. / Geared motor prices are different for IE2 and IE3 motors. / Preise von Getrieben mit IE2 und IE3 Motoren sind unterschiedlich.

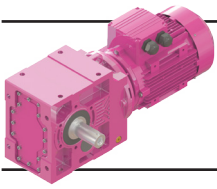

# K Serisi Motorlu Güç Devir Sayfaları

## K Series Geared Motors Performance Tables

### K Serien Getriebemotoren Leistung und Drehzahlübersicht

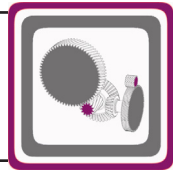

Güç	IE3 Çıkış Devri	IE3 Çıkış Momenti	Çevrim Oranı	IE3 Güv. Rad. Yük Çıkış	IE3 Servis Faktörü	Tipi	Anma Akımı	Ağırlık	Ölçü Sayfası	Motor Verim Snf.*	
Power	Output Speeds	Output Torque	Ratio	Per. O. Loads (Output)	Service Factors	Type	Rated Current	Weight	Dim. Page	Motor Eff. Class	
Leistung P <sub>g</sub> [kW] P <sub>g</sub> [HP]	Abtriebswelle Drehzahlen n <sub>2</sub> [r.p.m]	Abtriebswelle Drehmomente M <sub>2</sub> [Nm]	Übersetzung i	Zul.Querkräfte (Abtrieb) F <sub>qam</sub> [N]	Betriebsfaktor f <sub>s</sub>	Typ	Nennstrom [A]	Gewicht ~ [kg]	Maße Seite	Motor Effizienz- klasse	
4,0 5,5	352	103	8,28	11447	1,9	KR273-3E112M/2C	7,28	58	98	IE3	
	420	87	6,94	11066	2,2	KR273-2E112M/2A	7,50	54		IE2	
	138	265	10,57	5261	0,9	KR202-3E112M/4D	8,05	56	94	IE3	
	158	232	9,25	5021	1,0	KR202-2E112M/4C	8,20	54		IE2	
	191	192	7,65	4688	1,1						
	229	160	6,38	4385	1,3						
	315	116	9,25	3892	1,6	KR202-3E112M/2C	7,28	53	94	IE3	
	381	96	7,65	3625	1,8	KR202-2E112M/2A	7,50	48		IE2	
	457	80	6,38	3388	2,1						
	5,5	7,5									
	5,5 7,5	4,3	11227	339,70	95138	1,3	KR874-3E132S/4C	10,65	660	170	IE3
		5,1	9511	287,10	101336	1,6	KR874-2E132S/4B	11,05	654		IE2
6,2		7809	235,47	106545	1,9						
7,0		6909	207,95	109108	2,2						
8,4		5905	115,87	111829	2,5	KR873-3E132M/6D	11,55	652	166	IE3	
9,4		5267	103,24	113495	2,8	KR873-2E132M/6C	12,00	647		IE2	
10		4740	92,80	114627	3,2						
12		4137	81,06	116023	3,6						
5,2		9208	278,35	46845	0,9	KR774-3E132S/4C	10,65	429	158	IE3	
6,1		7954	240,71	55019	1,0	KR774-2E132S/4B	11,05	423		IE2	
7,0		6898	208,42	60535	1,2						
8,0		6042	182,29	64522	1,3						
8,7		5678	111,63	66155	1,4	KR773-3E132M/6D	11,55	407	154	IE3	
9,8		5042	99,00	68574	1,6	KR773-2E132M/6C	12,00	402		IE2	
11		4515	88,57	70527	1,8						
13		3902	76,59	72638	2,1						
13		3786	111,63	73041	2,1	KR773-3E132S/4C	10,65	399	154	IE3	
15		3362	99,00	74380	2,4	KR773-2E132S/4B	11,05	393		IE2	
16		3011	88,57	75433	2,7						
19		2602	76,59	76614	3,1						
22		2256	66,32	77554	3,5						
11		4582	90,21	25491	0,9	KR673-3E132M/6D	11,55	239	142	IE3	
						KR673-2E132M/6C	12,00	234		IE2	
11		4334	128,24	28038	1,0	KR673-3E132S/4C	10,65	249	142	IE3	
14		3413	100,90	35551	1,3	KR673-2E132S/4B	11,05	243		IE2	
16		3055	90,21	37921	1,4						
18		2725	80,38	39887	1,6						
21		2320	68,47	42076	1,9						
25		1998	58,86	43633	2,2						
29		1736	51,08	44809	2,5						
33		1520	44,65	45724	2,8						
15		3276	97,19	15243	0,8	KR573-3E132S/4C	10,65	180	130	IE3	
18		2773	82,14	21892	1,0	KR573-2E132S/4B	11,05	174		IE2	
22		2276	67,37	26421	1,2						
25		2012	59,49	28423	1,3						
28		1790	52,88	29925	1,5						
33	1517	44,73	32067	1,7							
38	1296	38,16	33803	1,9							
41	1199	35,34	34580	2,0							
48	1028	30,25	35853	2,2							
57	882	25,78	36406	2,6							
64	780	22,77	37145	2,8							

\*: IE2 ve IE3 motorlu redüktör fiyatları farklıdır. / Geared motor prices are different for IE2 and IE3 motors. / Preise von Getrieben mit IE2 und IE3 Motoren sind unterschiedlich.

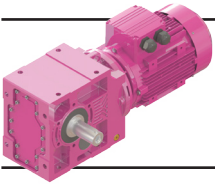

# K Serisi Motorlu Güç Devir Sayfaları

## K Series Geared Motors Performance Tables

### K Serien Getriebemotoren Leistung und Drehzahlübersicht

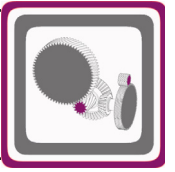

Güç	IE3 Çıkış Devri	IE3 Çıkış Momenti	Çevrim Oranı	IE3 Güv. Rad. Yük Çıkış	IE3 Servis Faktörü	Tipi	Anma Akımı	Ağırlık	Ölçü Sayfası	Motor Verim Snf.*	
Power	Output Speeds	Output Torque	Ratio	Per.O. Loads (Output)	Service Factors	Type	Rated Current	Weight	Dim. Page	Motor Eff. Class	
Leistung P <sub>g</sub> [kW] P <sub>g</sub> [HP]	Abtriebswelle Drehzahlen n <sub>2</sub> [r.p.m]	Abtriebswelle Drehmomente M <sub>2</sub> [Nm]	Übersetzung i	Zul.Querkräfte (Abtrieb) F <sub>qam</sub> [N]	Betriebsfaktor f <sub>s</sub>	Typ	Nennstrom [A]	Gewicht ~ [kg]	Maße Seite	Motor Effizienz-klasse	
5,5 7,5	29	1732	51,22	14734	0,9	KR473-3E132S/4C	10,65	138	118	IE3	
	33	1512	44,64	16950	1,0	KR473-2E132S/4B	11,05	132		IE2	
	37	1326	39,11	18473	1,2						
	48	1026	30,11	20584	1,5						
	58	859	25,15	21596	1,8						
	61	812	23,76	21378	1,9						
	63	792	23,19	21284	2,0						
	73	686	20,07	20704	2,2						
	83	599	17,49	20135	2,4						
	95	526	15,33	19577	2,6						
	106	469	13,71	18525	2,1						
	123	406	11,87	17983	2,4						
	141	355	10,34	17459	2,6						
	161	311	9,06	16950	2,9						
	195	258	7,48	16212	3,4						
	5,5 7,5	51	978	28,85	9843	0,8	KR373-3E132S/4C	10,65	103	106	IE3
		59	839	24,72	11823	1,0	KR373-2E132S/4B	11,05	97		IE2
		67	748	21,90	12848	1,1					
		78	637	18,62	13971	1,3					
92		547	15,96	14782	1,5						
101		495	14,44	15173	1,7						
118		424	12,38	15716	1,9						
138		364	10,60	15570	2,2						
146		342	9,97	15027	1,9						
171		293	8,54	14580	2,1						
189		266	7,73	14284	2,3						
220		228	6,63	13821	2,6						
257		195	5,68	13349	3,0						
5,5 7,5		176	283	8,28	10737	0,8	KR273-3E132S/4C	10,65	82	98	IE3
		210	237	6,94	10471	0,9	KR273-2E132S/4B	11,05	77		IE2
5,5 7,5		221	226	13,34	11775	1,3	KR273-3E132S/2B	9,90	73	98	
		245	203	12,00	11139	1,1	KR273-2E132S/2A	10,20	71		
		297	168	9,92	10966	1,3					
		356	140	8,28	10737	1,4					
	425	118	6,94	10471	1,6						
7,5 10	5,1	12925	287,10	88255	1,2	KR874-3E132M/4D	14,40	694	170	IE3	
	6,2	10613	235,47	97408	1,4	KR874-2E132M/4B	15,00	689		IE2	
	7,0	9389	207,95	101630	1,6						
	7,9	8358	184,83	104835	1,8						
	9,1	7308	161,34	107991	2,1						
	10	6457	142,32	110333	2,3						
	7,5 10	8,4	8054	115,87	105903	1,9	KR873-3E160M/6D	15,00	750	166	IE3
		9,4	7184	103,24	108410	2,1	KR873-2E160M/6B	15,00	750		IE2
		10	6465	92,80	110370	2,3					
		12	5643	81,06	112482	2,7					
		14	4933	70,76	114174	3,0					
		16	4358	62,42	115539	3,4					
	7,5 10	13	5352	115,87	113168	2,8	KR873-3E132M/4D	14,40	678	166	IE3
		14	4775	103,24	114564	3,1	KR873-2E132M/4C	15,00	673		IE2
		16	4297	92,80	115676	3,5					
		18	3751	81,06	116901	4,0					
	7,5 10	8,7	7745	111,63	56304	1,0	KR773-3E160M/6D	15,00	485	154	IE3
		9,8	6877	99,00	60758	1,2	KR773-2E160M/6B	15,00	485		IE2
11		6159	88,57	64101	1,3						
13		5322	76,59	67596	1,5						

\*: IE2 ve IE3 motorlu redüktör fiyatları farklıdır. / Geared motor prices are different for IE2 and IE3 motors. / Preise von Getrieben mit IE2 und IE3 Motoren sind unterschiedlich.

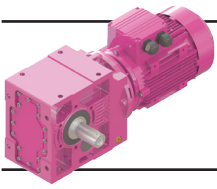

# K Serisi Motorlu Güç Devir Sayfaları

## K Series Geared Motors Performance Tables

### K Serien Getriebemotoren Leistung und Drehzahlübersicht

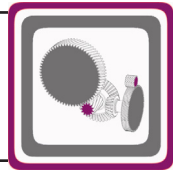

Güç	IE3 Çıkış Devri	IE3 Çıkış Momenti	Çevrim Oranı	IE3 Güv. Rad. Yük Çıkış	IE3 Servis Faktörü	Tipi	Anma Akımı	Ağırlık	Ölçü Sayfası	Motor Verim Snf.*
Power	Output Speeds	Output Torque	Ratio	Per. O. Loads (Output)	Service Factors	Type	Rated Current	Weight	Dim. Page	Motor Eff. Class
Leistung P <sub>g</sub> [kW] P <sub>g</sub> [HP]	Abtriebswelle Drehzahlen n <sub>2</sub> [r.p.m]	Abtriebswelle Drehmomente M <sub>2</sub> [Nm]	Übersetzung i	Zul.Querkräfte (Abtrieb) F <sub>qam</sub> [N]	Betriebsfaktor f <sub>s</sub>	Typ	Nennstrom [A]	Gewicht ~ [kg]	Maße Seite	Motor Effizienz- klasse
7,5 10	13	5147	111,63	68279	1,6	KR773-3E132M/4D	14,40	413	154	IE3
	15	4570	99,00	70363	1,8	KR773-2E132M/4C	15,00	408		IE2
	17	4093	88,57	72024	2,0					
	19	3537	76,59	73873	2,3					
	22	3068	66,32	75293	2,6					
	25	2687	58,00	76366	3,0					
	29	2372	51,13	77246	3,4					
	15	4640	100,90	24872	0,9	KR673-3E132M/4D	14,40	262	142	IE3
	16	4153	90,21	29758	1,0	KR673-2E132M/4C	15,00	257		IE2
	18	3705	80,38	33503	1,2					
	21	3154	68,47	37291	1,4					
	25	2716	58,86	39941	1,6					
	29	2360	51,08	41901	1,8					
	33	2066	44,65	43357	2,1					
	45	1519	32,68	45726	2,8					
	52	1308	28,10	46568	3,3					
	22	3094	67,37	18091	0,9	KR573-3E132M/4D	14,40	193	130	IE3
	25	2735	59,49	22291	1,0	KR573-2E132M/4C	15,00	188		IE2
	28	2434	52,88	25162	1,1					
	33	2062	44,73	28634	1,3					
	38	1761	38,16	31327	1,4					
	41	1630	35,34	32457	1,5					
	48	1397	30,25	34261	1,6					
	57	1199	25,78	35160	1,9					
	64	1060	22,77	36129	2,1					
	72	943	20,24	36931	2,2					
	78	875	18,80	37332	2,3					
	92	741	15,88	36353	2,6					
	108	632	13,53	34997	2,9					
127	542	11,58	33696	3,1						
37	1803	39,11	13919	0,9	KR473-3E132M/4D	14,40	151	118	IE3	
49	1395	30,11	17939	1,1	KR473-2E132M/4C	15,00	146		IE2	
58	1168	25,15	19645	1,3						
62	1104	23,76	20070	1,4						
63	1076	23,19	20007	1,4						
73	933	20,07	19599	1,6						
84	814	17,49	19172	1,7						
96	715	15,33	18733	1,9						
107	637	13,71	17560	1,6						
123	553	11,87	17148	1,8						
142	482	10,34	16731	1,9						
162	423	9,06	16312	2,1						
196	350	7,48	15685	2,5						
236	291	6,21	15061	2,9						
248	275	11,87	17148	2,8	KR473-3E132S/2C	13,20	134	118	IE3	
285	240	10,34	16731	3,2	KR473-2E132S/2B	13,60	127		IE2	
325	211	9,06	16312	3,5						
67	1017	21,90	9185	0,8	KR373-3E132M/4D	14,40	118	106	IE3	
79	866	18,62	11470	0,9	KR373-2E132M/4C	15,00	113		IE2	
92	743	15,96	12926	1,1						
101	673	14,44	13644	1,2						
118	577	12,38	14526	1,4						
138	495	10,60	14773	1,6						
147	465	9,97	14152	1,4						
172	399	8,54	13833	1,6						
190	361	7,73	13609	1,7						
221	310	6,63	13242	1,9						
258	266	5,68	12854	2,2						

\*: IE2 ve IE3 motorlu redüktör fiyatları farklıdır. / Geared motor prices are different for IE2 and IE3 motors. / Preise von Getrieben mit IE2 und IE3 Motoren sind unterschiedlich.

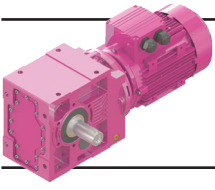

# K Serisi Motorlu Güç Devir Sayfaları

## K Series Geared Motors Performance Tables

### K Serien Getriebemotoren Leistung und Drehzahlübersicht

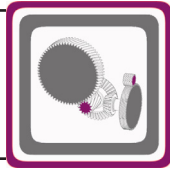

Güç	IE3 Çıkış Devri	IE3 Çıkış Momenti	Çevrim Oranı	IE3 Güv. Rad. Yük Çıkış	IE3 Servis Faktörü	Tipi	Anma Akımı	Ağırlık	Ölçü Sayfası	Motor Verim Snf.*
Power	Output Speeds	Output Torque	Ratio	Per.O. Loads (Output)	Service Factors	Type	Rated Current	Weight	Dim. Page	Motor Eff. Class
Leistung P <sub>g</sub> [kW] P <sub>g</sub> [HP]	Abtriebswelle Drehzahlen n <sub>2</sub> [r.p.m]	Abtriebswelle Drehmomente M <sub>2</sub> [Nm]	Übersetzung i	Zul.Querkräfte (Abtrieb) F <sub>qam</sub> [N]	Betriebsfaktor f <sub>s</sub>	Typ	Nennstrom [A]	Gewicht ~ [kg]	Maße Seite	Motor Effizienz-klasse
7,5 10	278	247	10,60	14773	2,6	KR373-3E132S/2C	13,20	111	106	IE3
	295	232	9,97	14152	2,3	KR373-2E132S/2B	13,60	104		IE2
	345	199	8,54	13833	2,6					
	381	180	7,73	13609	2,8					
	444	154	6,63	13242	3,1					
	185	368	15,92	10344	0,8	KR273-3E132S/2C	13,20	77	98	IE3
	221	309	13,34	10459	1,0	KR273-2E132S/2B	13,60	71		IE2
	245	277	12,00	9767	0,8					
	297	229	9,92	9831	0,9					
	356	192	8,28	9791	1,0					
425	161	6,94	9677	1,2						
11 15	8,0	12217	184,83	91409	1,2	KR874-3E160M/4C	21,00	762	170	IE3
	9,1	10683	161,34	97286	1,4	KR874-2E160M/4B	21,00	772		IE2
	10	9438	142,32	101572	1,6					
	8,4	11819	115,87	93008	1,3	KR873-3E160L/6E	21,50	766	166	IE3
	9,4	10543	103,24	97791	1,4	KR873-2E160L/6D	22,00	766		IE2
	10	9488	92,80	101239	1,6					
	12	8282	81,06	105084	1,8					
	12	8213	115,87	105498	1,8	KR873-3E160M/4C	21,00	741	166	IE3
	14	7327	103,24	108095	2,0	KR873-2E160M/4B	21,00	751		IE2
	15	6593	92,80	110090	2,3					
	17	5756	81,06	112392	2,6					
	20	5032	70,76	114064	3,0					
	22	4445	62,42	115398	3,4					
	11	9038	88,57	48219	0,9	KR773-3E160L/6E	21,50	450	154	IE3
	13	7810	76,59	55843	1,0	KR773-2E160L/6D	22,00	450		IE2
	13	7525	111,63	57419	1,1	KR773-3E160M/4C	21,00	476	154	IE3
	15	6682	99,00	61698	1,2	KR773-2E160M/4B	21,00	486		IE2
	17	5984	88,57	64860	1,3					
	19	5172	76,59	68181	1,5					
	22	4485	66,32	70695	1,8					
	25	3928	58,00	72610	2,0					
	29	3468	51,13	74086	2,3					
	32	3080	45,36	73382	2,6					
	36	2749	40,44	71725	2,9					
38	2649	39,00	71192	3,0						
44	2298	33,78	69061	3,5						
21	4612	68,47	25154	0,9	KR673-3E160M/4C	21,00	322	142	IE3	
25	3971	58,86	31365	1,1	KR673-2E160M/4B	21,00	332		IE2	
29	3451	51,08	35367	1,2						
33	3021	44,65	38196	1,4						
37	2659	39,26	40310	1,6						
45	2221	32,68	42597	1,9						
52	1913	28,10	44063	2,2						
60	1663	24,38	45097	2,6						
69	1456	21,32	45997	3,0						
78	1281	18,74	46687	3,4						

\*: IE2 ve IE3 motorlu redüktör fiyatları farklıdır. / Geared motor prices are different for IE2 and IE3 motors. / Preise von Getrieben mit IE2 und IE3 Motoren sind unterschiedlich.

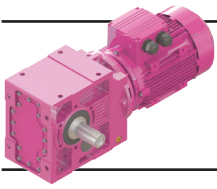

# K Serisi Motorlu Güç Devir Sayfaları

## K Series Geared Motors Performance Tables

### K Serien Getriebemotoren Leistung und Drehzahlübersicht

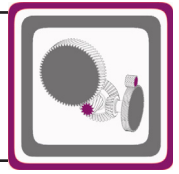

Güç	IE3 Çıkış Devri	IE3 Çıkış Momenti	Çevrim Oranı	IE3 Güv. Rad. Yük Çıkış	IE3 Servis Faktörü	Tipi	Anma Akımı	Ağırlık	Ölçü Sayfası	Motor Verim Snf.*	
Power	Output Speeds	Output Torque	Ratio	Per. O. Loads (Output)	Service Factors	Type	Rated Current	Weight	Dim. Page	Motor Eff. Class	
Leistung P <sub>g</sub> [kW] P <sub>g</sub> [HP]	Abtriebswelle Drehzahlen n <sub>2</sub> [r.p.m]	Abtriebswelle Drehmomente M <sub>2</sub> [Nm]	Übersetzung i	Zul.Querkräfte (Abtrieb) F <sub>qam</sub> [N]	Betriebsfaktor f <sub>s</sub>	Typ	Nennstrom [A]	Gewicht ~ [kg]	Maße Seite	Motor Effizienz-klasse	
11 15	33	3015	44,73	20090	0,9	KR573-3E160M/4C	21,00	257	130	IE3	
	39	2575	38,16	25664	1,0	KR573-2E160M/4B	21,00	267		IE2	
	42	2383	35,34	27743	1,0						
	49	2042	30,25	30881	1,1						
	57	1752	25,78	32523	1,3						
	65	1550	22,77	34000	1,4						
	73	1379	20,24	35220	1,5						
	78	1279	18,80	35839	1,6						
	93	1083	15,88	34717	1,8						
	109	924	13,53	33604	2,0						
	127	792	11,58	32503	2,1						
	131	764	11,22	31906	1,9						
	155	647	9,48	30758	2,1						
	182	552	8,07	29654	2,4						
	213	473	6,91	28586	2,6						
	63 73 84 96 107 124 142 162 196 237	1574	23,19	16370	1,0	KR473-3E160M/4C	21,00	214	118	IE3	
		1364	20,07	17666	1,1	KR473-2E160M/4B	21,00	224		IE2	
		1191	17,49	17487	1,2						
		1045	15,33	17257	1,3						
		932	13,71	15872	1,1						
808		11,87	15688	1,2							
705		10,34	15458	1,3							
619		9,06	15197	1,5							
512		7,48	14764	1,7							
426		6,21	14296	1,9							
15 20		9,4	14306	103,24	82207	1,0	KR873-3E180L/6E	29,00	809	166	IE3
		11	12874	92,80	88673	1,2	KR873-2E180L/6D	29,00	789		IE2
		12	11237	81,06	95249	1,3					
		13	10673	115,87	97450	1,4	KR873-3E160L/4D	29,00	766	166	IE3
	14	9522	103,24	101404	1,6	KR873-2E160L/4C	29,30	763		IE2	
	16	8569	92,80	104431	1,8						
	18	7480	81,06	107574	2,0						
	21	6540	70,76	110229	2,3						
	24	5778	62,42	112156	2,6						
	26	5147	55,53	113745	2,9						
	30	4616	49,75	114934	3,2						
	15 17 19 22 25 29 32 36 38 44 50 55 62	9113	99,00	47536	0,9	KR773-3E160L/4D	29,00	501	154	IE3	
8162		88,57	53663	1,0	KR773-2E160L/4C	29,30	498		IE2		
7054		76,59	59800	1,1							
6117		66,32	64248	1,3							
5358		58,00	67449	1,5							
4730		51,13	69758	1,7							
4201		45,36	69360	1,9							
3750		40,44	68138	2,1							
3613		39,00	67733	2,2							
3134		33,78	66065	2,6							
2731		29,40	64367	2,9							
2468		26,52	63065	3,2							
2193		23,52	61523	3,6							
29 33 37 45 52 60 69 78 89 101 118		4707	51,08	23948	0,9	KR673-3E160L/4D	29,00	363	142	IE3	
	4120	44,65	30057	1,0	KR673-2E160L/4C	29,30	360		IE2		
	3627	39,26	34185	1,2							
	3030	32,68	38205	1,4							
	2609	28,10	40633	1,6							
	2268	24,38	42359	1,9							
	1986	21,32	43740	2,2							
	1748	18,74	44807	2,5							
	1545	16,54	45641	2,8							
	1347	14,49	50991	2,2							
	1161	12,46	50192	2,4							

\*: IE2 ve IE3 motorlu reductör fiyatları farklıdır. / Geared motor prices are different for IE2 and IE3 motors. / Preise von Getrieben mit IE2 und IE3 Motoren sind unterschiedlich.

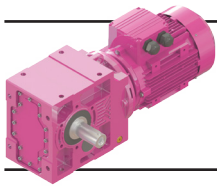

# K Serisi Motorlu Güç Devir Sayfaları

## K Series Geared Motors Performance Tables

### K Serien Getriebemotoren Leistung und Drehzahlübersicht

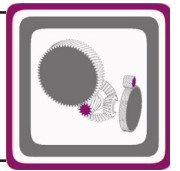

Güç	IE3 Çıkış Devri	IE3 Çıkış Momenti	Çevrim Oranı	IE3 Güv. Rad. Yük Çıkış	IE3 Servis Faktörü	Tipi	Anma Akımı	Ağırlık	Ölçü Sayfası	Motor Verim Snf.*
Power	Output Speeds	Output Torque	Ratio	Per.O. Loads (Output)	Service Factors	Type	Rated Current	Weight	Dim. Page	Motor Eff. Class
Leistung P <sub>g</sub> [kW] P <sub>g</sub> [HP]	Abtriebswelle Drehzahlen n <sub>2</sub> [r.p.m]	Abtriebswelle Drehmomente M <sub>2</sub> [Nm]	Übersetzung i	Zul.Querkräfte (Abtrieb) F <sub>qam</sub> [N]	Betriebsfaktor f <sub>s</sub>	Typ	Nennstrom [A]	Gewicht ~ [kg]	Maße Seite	Motor Effizienz-klasse
15 20	136	1009	10,81	48599	2,7	KR673-3E160L/4D	29,00	363	142	IE3
	156	883	9,45	47088	2,9	KR673-2E160L/4C	29,30	360		IE2
	177	778	8,31	45648	3,2					
	57	2390	25,78	28613	1,0	KR573-3E160L/4D	29,00	281	130	IE3
	65	2114	22,77	31047	1,0	KR573-2E160L/4C	29,30	278		IE2
	73	1881	20,24	32895	1,1					
	78	1745	18,80	33626	1,2					
	93	1477	15,88	32847	1,3					
	109	1260	13,53	32012	1,4					
	127	1080	11,58	31140	1,6					
	131	1043	11,22	30448	1,4					
	155	883	9,48	29526	1,6					
	182	753	8,07	28605	1,7					
	213	646	6,91	27688	1,9					
	84	1624	17,49	15562	0,9	KR473-3E160L/4D	29,00	240	118	IE3
	96	1425	15,33	15570	1,0	KR473-2E160L/4C	29,30	237		IE2
	107	1271	13,71	13943	0,8					
	124	1102	11,87	14018	0,9					
	142	962	10,34	14003	1,0					
	162	844	9,06	13922	1,1					
	196	699	7,48	13711	1,2					
	237	581	6,21	13422	1,4					
18,5 25	13	12640	113,42	89656	1,2	KR874-3E180M/4C	34,50	821	170	IE3
	15	10983	98,53	96189	1,4	KR874-2E180M/4B	34,50	821		IE2
	12	13858	81,06	84247	1,1	KR873-3G200L/6a	36,50	807	166	IE3
	14	12115	70,76	91801	1,2	KR873-2G200L/6a	36,50	807		IE2
	14	11704	103,24	93451	1,3	KR873-3E180M/4C	34,50	804	166	IE3
	16	10533	92,80	97821	1,4	KR873-2E180M/4B	34,50	804		IE2
	18	9195	81,06	102364	1,6					
	21	8040	70,76	105817	1,9					
	24	7102	62,42	108630	2,1					
	27	6327	55,53	110730	2,4					
	30	5674	49,75	112387	2,6					
	34	4930	43,22	114806	3,0					
	39	4341	38,00	112515	3,3					
	19	8671	76,59	50588	0,9	KR773-3E180M/4C	34,50	537	154	IE3
	22	7520	66,32	57472	1,1	KR773-2E180M/4B	34,50	537		IE2
	25	6586	58,00	62026	1,2					
	29	5814	51,13	65570	1,4					
	33	5164	45,36	65841	1,5					
	36	4610	40,44	65000	1,7					
	38	4441	39,00	64707	1,8					
	44	3853	33,78	63444	2,1					
	50	3358	29,40	62085	2,4					
	56	3034	26,52	61007	2,6					
	63	2695	23,52	59698	3,0					
	70	2406	20,97	58398	3,3					
	73	2318	20,23	57978	3,4					
	33	5065	44,65	19115	0,8	KR673-3E180M/4C	34,50	399	142	IE3
	38	4458	39,26	26817	1,0	KR673-2E180M/4B	34,50	399		IE2
	45	3724	32,68	33355	1,2					
	52	3207	28,10	37015	1,3					
	60	2788	24,38	39559	1,5					
	69	2441	21,32	41471	1,8					
	79	2149	18,74	42949	2,0					

\*: IE2 ve IE3 motorlu redüktör fiyatları farklıdır. / Geared motor prices are different for IE2 and IE3 motors. / Preise von Getrieben mit IE2 und IE3 Motoren sind unterschiedlich.

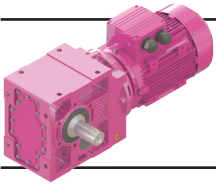

# K Serisi Motorlu Güç Devir Sayfaları

## K Series Geared Motors Performance Tables

### K Serien Getriebemotoren Leistung und Drehzahlübersicht

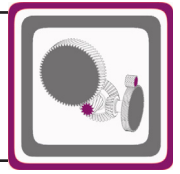

Güç	IE3 Çıkış Devri	IE3 Çıkış Momenti	Çevrim Oranı	IE3 Güv. Rad. Yük Çıkış	IE3 Servis Faktörü	Tipi	Anma Akımı	Ağırlık	Ölçü Sayfası	Motor Verim Snf.*
Power	Output Speeds	Output Torque	Ratio	Per. O. Loads (Output)	Service Factors	Type	Rated Current	Weight	Dim. Page	Motor Eff. Class
Leistung P <sub>g</sub> [kW] P <sub>g</sub> [HP]	Abtriebswelle Drehzahlen n <sub>2</sub> [r.p.m]	Abtriebswelle Drehmomente M <sub>2</sub> [Nm]	Übersetzung i	Zul.Querkräfte (Abtrieb) F <sub>qam</sub> [N]	Betriebsfaktor f <sub>s</sub>	Typ	Nennstrom [A]	Gewicht ~ [kg]	Maße Seite	Motor Effizienz-klasse
18,5 25	89	1899	16,54	44104	2,3	KR673-3E180M/4C KR673-2E180M/4B	34,50	399	142	IE3
	102	1656	14,49	50128	1,8		34,50	399		IE2
	118	1427	12,46	48913	2,0					
	136	1240	10,81	47488	2,2					
	156	1086	9,45	46117	2,4					
	178	956	8,31	44795	2,6					
	65	2598	22,77	27790	0,8	KR573-3E180M/4C KR573-2E180M/4B	34,50	321	130	IE3
	73	2313	20,24	30454	0,9		34,50	321		IE2
	78	2145	18,80	31689	1,0					
	93	1816	15,88	31210	1,1					
	109	1549	13,53	30618	1,2					
	127	1328	11,58	29948	1,3					
	131	1282	11,22	29173	1,1					
	156	1085	9,48	28449	1,3					
	183	926	8,07	27687	1,4					
	213	794	6,91	26903	1,5					
	163	1038	9,06	12807	0,9	KR473-3E180M/4C KR473-2E180M/4B	34,50	279	118	IE3
	197	859	7,48	12790	1,0		34,50	279		IE2
237	714	6,21	12658	1,2						
22 30	12	16483	81,06	70303	0,9	KR873-3G200L/6b KR873-2G200L/6b	43,00	827	166	IE3
	14	14410	70,76	81609	1,0		43,00	827		IE2
	14	13920	103,24	83967	1,1	KR873-3E180L/4D KR873-2E180L/4C	42,50	844	166	IE3
	16	12527	92,80	90131	1,2		42,50	844		IE2
	18	10936	81,06	96365	1,4					
	21	9561	70,76	101165	1,6					
	24	8447	62,42	104716	1,8					
	27	7524	55,53	107357	2,0					
	30	6748	49,75	109595	2,2					
	34	5864	43,22	112553	2,5					
	39	5163	38,00	110238	2,8					
	43	4664	34,28	107854	3,0					
	22	8943	66,32	48734	0,9	KR773-3E180L/4D KR773-2E180L/4C	42,50	578	154	IE3
	25	7833	58,00	55713	1,0		42,50	578		IE2
	29	6915	51,13	60547	1,2					
	33	6142	45,36	62321	1,3					
	36	5482	40,44	61862	1,5					
	38	5282	39,00	61681	1,5					
	44	4582	33,78	60823	1,7					
	50	3993	29,40	59804	2,0					
	56	3609	26,52	58950	2,2					
	63	3206	23,52	57873	2,5					
	70	2862	20,97	56770	2,8					
	73	2757	20,23	56409	2,9					
	84	2392	17,52	54934	3,2					
	97	2085	15,25	53450	3,5					
	45	4429	32,68	27119	1,0	KR673-3E180L/4D KR673-2E180L/4C	42,50	439	142	IE3
	52	3815	28,10	32647	1,1		42,50	439		IE2
	60	3316	24,38	36295	1,3					
	69	2903	21,32	38906	1,5					
	79	2556	18,74	40876	1,7					
	89	2259	16,54	42403	1,9					
	102	1970	14,49	48904	1,5					
	118	1697	12,46	47633	1,7					
	136	1475	10,81	46378	1,8					
	156	1291	9,45	45147	2,0					
178	1137	8,31	43941	2,2						

\*: IE2 ve IE3 motorlu redüktör fiyatları farklıdır. / Geared motor prices are different for IE2 and IE3 motors. / Preise von Getrieben mit IE2 und IE3 Motoren sind unterschiedlich.



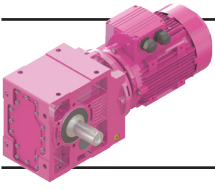

# K Serisi Motorlu Güç Devir Sayfaları

## K Series Geared Motors Performance Tables

### K Serien Getriebemotoren Leistung und Drehzahlübersicht

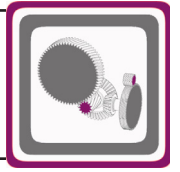

Güç	IE3 Çıkış Devri	IE3 Çıkış Momenti	Çevrim Oranı	IE3 Güv. Rad. Yük Çıkış	IE3 Servis Faktörü	Tipi	Anma Akımı	Ağırlık	Ölçü Sayfası	Motor Verim Snf.*	
Power	Output Speeds	Output Torque	Ratio	Per.O. Loads (Output)	Service Factors	Type	Rated Current	Weight	Dim. Page	Motor Eff. Class	
Leistung P <sub>g</sub> [kW] P <sub>g</sub> [HP]	Abtriebswelle Drehzahlen n <sub>2</sub> [r.p.m]	Abtriebswelle Drehmomente M <sub>2</sub> [Nm]	Übersetzung i	Zul.Querkräfte (Abtrieb) F <sub>qam</sub> [N]	Betriebsfaktor f <sub>s</sub>	Typ	Nennstrom [A]	Gewicht ~ [kg]	Maße Seite	Motor Effizienz-klasse	
22 30	93	2160	15,88	29574	0,9	KR573-3E180L/4D	42,50	361	130	IE3	
	109	1842	13,53	29225	1,0	KR573-2E180L/4C	42,50	361		IE2	
	127	1580	11,58	28755	1,1						
	131	1525	11,22	27898	1,0						
	156	1291	9,48	27371	1,1						
	183	1101	8,07	26769	1,2						
	213	944	6,91	26117	1,3						
	197	1021	7,48	11869	0,8	KR473-3E180L/4D	42,50	319	118	IE3	
	237	849	6,21	11893	1,0	KR473-2E180L/4C	42,50	319		IE2	
	30 40	18	14913	81,06	79086	1,0	KR873-3G200L/4	55,00	868	166	IE3
		21	13039	70,76	87943	1,2	KR873-2G200L/4	55,00	855		IE2
		24	11519	62,42	94173	1,3					
		27	10261	55,53	98787	1,5					
		30	9203	49,75	102239	1,6					
34		7997	43,22	106655	1,8						
39		7041	38,00	105031	2,0						
43		6361	34,28	103156	2,2						
49		5550	29,88	100537	2,4						
61		4516	24,28	96417	3,1						
33		8376	45,36	52467	1,0	KR773-3G200L/4	55,00	601	154	IE3	
36		7477	40,44	54688	1,1	KR773-2G200L/4	55,00	588		IE2	
38		7204	39,00	54764	1,1						
44		6249	33,78	54831	1,3						
50		5446	29,40	54590	1,5						
56		4922	26,52	54247	1,6						
63		4372	23,52	53701	1,8						
70		3903	20,97	53050	2,0						
73		3760	20,23	52822	2,1						
84		3262	17,52	51826	2,3						
97		2843	15,25	50746	2,6						
114		2398	12,89	47780	1,9						
129		2130	11,44	46879	2,1						
145		1902	10,20	45962	2,2						
150		1832	9,83	45662	2,3						
173		1590	8,52	44444	2,5						
199		1385	7,41	43223	2,8						
60		4522	24,38	26181	1,0	KR673-3G200L/4	55,00	460	142	IE3	
69		3959	21,32	31466	1,1	KR673-2G200L/4	55,00	447		IE2	
79		3485	18,74	35118	1,2						
89		3081	16,54	37819	1,4						
102		2687	14,49	45501	1,1						
118	2314	12,46	44708	1,2							
136	2012	10,81	43839	1,3							
156	1761	9,45	42927	1,5							
178	1551	8,31	41990	1,6							
37 50	27	12656	55,53	89463	1,2	KR873-3G225S/4	67,00	970	166	IE3	
	30	11351	49,75	94671	1,3	KR873-2G225S/4	67,00	954		IE2	
	34	9864	43,22	100882	1,5						
	39	8685	38,00	100472	1,6						
	43	7845	34,28	99043	1,8						
	49	6846	29,88	96954	1,9						
	61	5570	24,28	93506	2,5						
	69	4904	21,34	91240	2,8						
	77	4430	19,26	89380	3,0						
	88	3866	16,78	86841	3,3						
	106	3203	13,93	82152	2,7						

\*: IE2 ve IE3 motorlu redüktör fiyatları farklıdır. / Geared motor prices are different for IE2 and IE3 motors. / Preise von Getrieben mit IE2 und IE3 Motoren sind unterschiedlich.

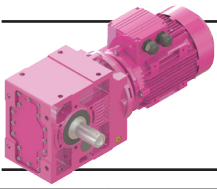

# K Serisi Motorlu Güç Devir Sayfaları

## K Series Geared Motors Performance Tables

### K Serien Getriebemotoren Leistung und Drehzahlübersicht

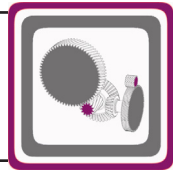

Güç	IE3 Çıkış Devri	IE3 Çıkış Momenti	Çevrim Oranı	IE3 Güv. Rad. Yük Çıkış	IE3 Servis Faktörü	Tipi	Anma Akımı	Ağırlık	Ölçü Sayfası	Motor* Verim Snf.
Power	Output Speeds	Output Torque	Ratio	Per.O. Loads (Output)	Service Factors	Type	Rated Current	Weight	Dim. Page	Motor Eff. Class
Leistung P <sub>g</sub> [kW] P <sub>g</sub> [HP]	Abtriebswelle Drehzahlen n <sub>2</sub> [r.p.m]	Abtriebswelle Drehmomente M <sub>2</sub> [Nm]	Übersetzung i	Zul.Querkräfte (Abtrieb) F <sub>qam</sub> [N]	Betriebsfaktor f <sub>s</sub>	Typ	Nennstrom [A]	Gewicht ~ [kg]	Maße Seite	Motor Effizienz-klasse
37 50	120	2820	12,25	79871	3,0	KR873-3G225S/4	67,00	970	166	IE3
	133	2547	11,05	78039	3,2	KR873-2G225S/4	67,00	954		IE2
	38	8885	39,00	48711	0,9	KR773-3G225S/4	67,00	693	154	IE3
	44	7708	33,78	49588	1,0	KR773-2G225S/4	67,00	677		IE2
	50	6717	29,40	50027	1,2					
	56	6071	26,52	50131	1,3					
	63	5393	23,52	50050	1,5					
	70	4814	20,97	49795	1,7					
	73	4638	20,23	49683	1,7					
	84	4024	17,52	49108	1,9					
	97	3507	15,25	48380	2,1					
	114	2958	12,89	45420	1,5					
	129	2628	11,44	44785	1,7					
	145	2346	10,20	44095	1,8					
	150	2260	9,83	43862	1,9					
	173	1961	8,52	42884	2,1					
	199	1709	7,41	41866	2,3					
	45 60	79	4299	18,74	28379	1,0	KR673-3G225S/4	67,00	552	142
89		3800	16,54	32786	1,1	KR673-2G225S/4	67,00	536		IE2
156		2173	9,45	40986	1,2					
178		1913	8,31	40283	1,3					
27		15394	55,53	76594	1,0	KR873-3G225M/4	80,00	1002	166	IE3
30		13806	49,75	84676	1,1	KR873-2G225M/4	80,00	1002		IE2
34		11997	43,22	93288	1,2					
39		10563	38,00	95261	1,3					
43		9542	34,28	94342	1,4					
49		8327	29,88	92857	1,6					
61		6775	24,28	90179	2,1					
69		5965	21,34	88315	2,3					
77		5389	19,26	86741	2,4					
88		4702	16,78	84541	2,7					
106		3895	13,93	79985	2,2					
120		3430	12,25	77966	2,4					
133		3099	11,05	76320	2,6					
153		2704	9,63	74086	2,9					
55 75	50	8170	29,40	44812	1,0	KR773-3G225M/4	80,00	728	154	IE3
	56	7384	26,52	45428	1,1	KR773-2G225M/4	80,00	728		IE2
	63	6559	23,52	45877	1,2					
	70	5855	20,97	46075	1,4					
	73	5642	20,23	46095	1,4					
	84	4894	17,52	46000	1,5					
	97	4265	15,25	45676	1,7					
	114	3598	12,89	42722	1,3					
	129	3196	11,44	42392	1,4					
	145	2853	10,20	41961	1,5					
	150	2749	9,83	41805	1,5					
	173	2385	8,52	41102	1,7					
	199	2079	7,41	40315	1,9					
	156	2643	9,45	38766	1,0	KR673-3G225M/4	80,00	587	142	IE3
	178	2327	8,31	38332	1,1	KR673-2G225M/4	80,00	587		IE2
	34	14614	43,22	81836	1,0	KR873-3G250M/4	96,00	1093	166	IE3
	39	12867	38,00	88743	1,1	KR873-2G250M/4	96,00	1093		IE2
	43	11624	34,28	88461	1,2					

\*: IE2 ve IE3 motorlu redüktör fiyatları farklıdır. / Geared motor prices are different for IE2 and IE3 motors. / Preise von Getrieben mit IE2 und IE3 Motoren sind unterschiedlich.

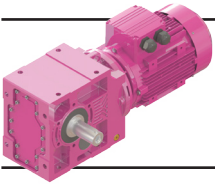

## K Serisi Motorlu Güç Devir Sayfaları

### K Series Geared Motors Performance Tables

#### K Serien Getriebemotoren Leistung und Drehzahlübersicht

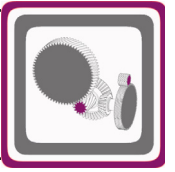

Güç	IE3 Çıkış Devri	IE3 Çıkış Momenti	Çevrim Oranı	IE3 Güv. Rad. Yük Çıkış	IE3 Servis Faktörü	Tipi	Anma Akımı	Ağırlık	Ölçü Sayfası	Motor Verim Snf.*	
Power	Output Speeds	Output Torque	Ratio	Per.O. Loads (Output)	Service Factors	Type	Rated Current	Weight	Dim. Page	Motor Eff. Class	
Leistung P <sub>g</sub> [kW] P <sub>g</sub> [HP]	Abtriebswelle Drehzahlen n <sub>2</sub> [r.p.m]	Abtriebswelle Drehmomente M <sub>2</sub> [Nm]	Übersetzung i	Zul.Querkräfte (Abtrieb) F <sub>qam</sub> [N]	Betriebsfaktor f <sub>s</sub>	Typ	Nennstrom [A]	Gewicht ~ [kg]	Maße Seite	Motor Effizienz-klasse	
55 75	50	10143	29,88	87734	1,3	KR873-3G250M/4	96,00	1093	166	IE3	
	61	8252	24,28	86018	1,7	KR873-2G250M/4	96,00	1093		IE2	
	69	7266	21,34	84657	1,9						
	77	6564	19,26	83440	2,0						
	88	5728	16,78	81666	2,2						
	106	4745	13,93	77275	1,8						
	121	4178	12,25	75584	2,0						
	134	3775	11,05	74170	2,1						
	154	3294	9,63	72213	2,4						
		63	7990	23,52	40661	1,0	KR773-3G250M/4	96,00	818	154	IE3
		71	7133	20,97	41424	1,1	KR773-2G250M/4	96,00	818		IE2
		73	6872	20,23	41611	1,1					
		84	5962	17,52	42116	1,3					
		97	5196	15,25	42296	1,4					
	115	4383	12,89	39350	1,0						
	129	3894	11,44	39400	1,1						
	145	3476	10,20	39294	1,2						
	151	3349	9,83	39232	1,3						
	174	2906	8,52	38874	1,4						
	200	2532	7,41	38376	1,5						
75 97	50	13786	29,88	77481	1,0	KR873-3G280S/4	133,00	1280	166	IE3	
	61	11216	24,28	77690	1,3	KR873-2G280S/4	133,00	1280		IE2	
	70	9876	21,34	77337	1,4						
	77	8922	19,26	76837	1,5						
	88	7785	16,78	75912	1,6						
	107	6450	13,93	71851	1,3						
	121	5679	12,25	70816	1,5						
	134	5130	11,05	69869	1,6						
	154	4477	9,63	68466	1,8						
		61	13460	24,28	71440	1,0	KR873-3G280M/4	158,00	1350	166	IE3
	70	11852	21,34	71843	1,1	KR873-2G280M/4	158,00	1350		IE2	
	77	10707	19,26	71881	1,2						
	88	9343	16,78	71594	1,3						
	107	7740	13,93	67780	1,1						
	121	6815	12,25	67238	1,2						
	134	6157	11,05	66642	1,3						
	154	5373	9,63	65653	1,5						

\*: IE2 ve IE3 motorlu redüktör fiyatları farklıdır. / Geared motor prices are different for IE2 and IE3 motors. / Preise von Getrieben mit IE2 und IE3 Motoren sind unterschiedlich.



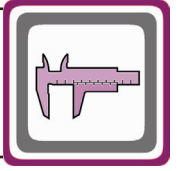
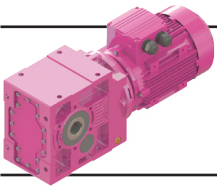

# Ölçü Sayfaları

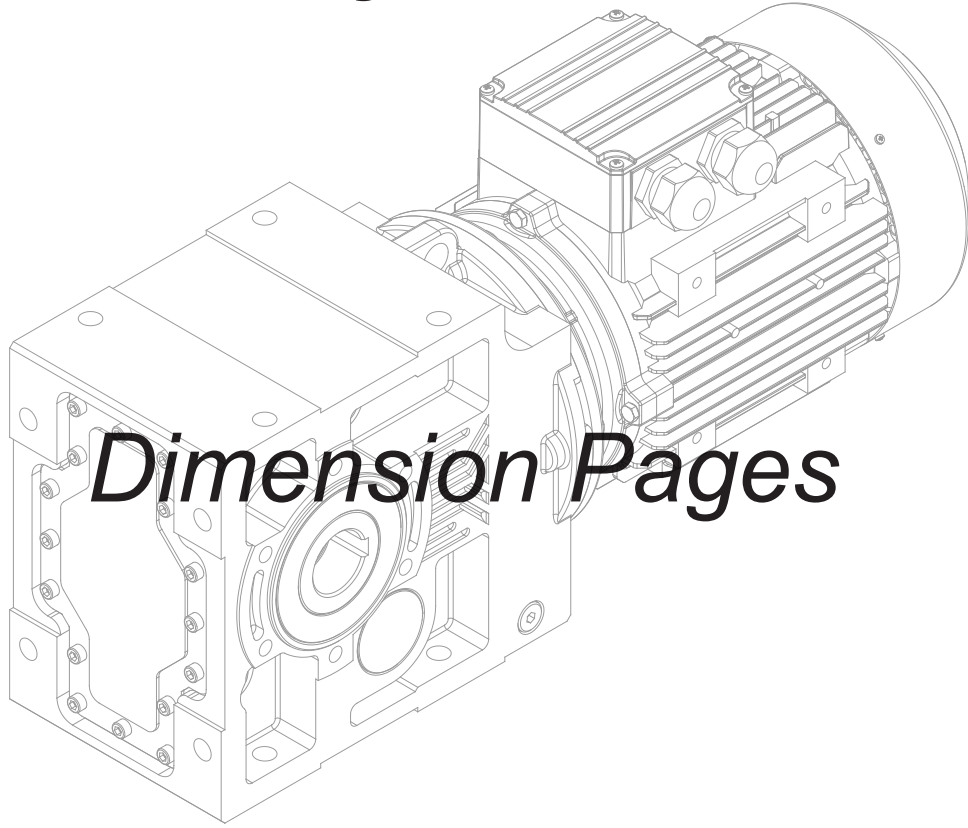

*Dimension Pages*

Abmessungenseiten

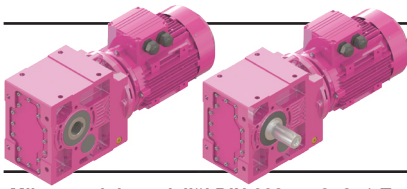

# Ölçü Sayfaları

## Dimension Pages

### Abmessungsseiten

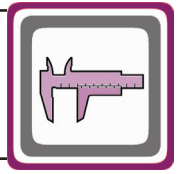

-Mil ucu çekirme deliği DIN 332 sayfa 2 / Tapped center hole to DIN 332, sheet 2 / Zentrierung mit Gewinde DIN 332, Blatt 2

KR002.00  
KR003.00

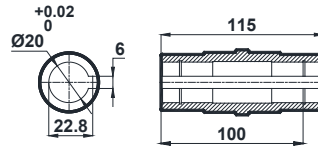
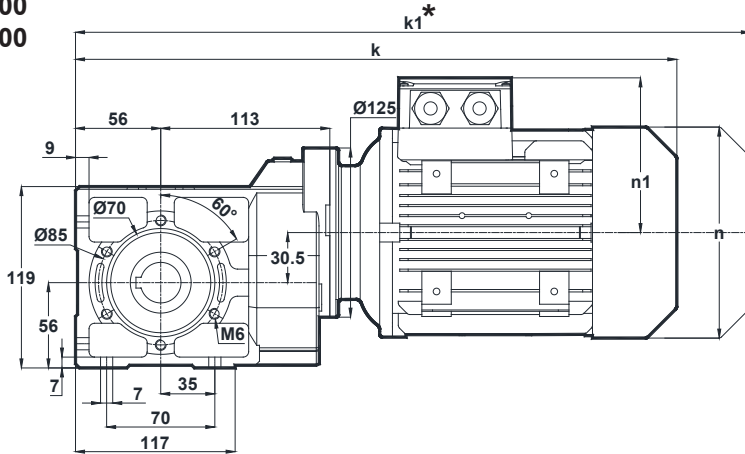

	63	71	80	90S	90L
k	366	395	429	468	468
k1	427	486	522	572.5	572.5
n	121	137	155	176	176
n1	97	112	121	132	132

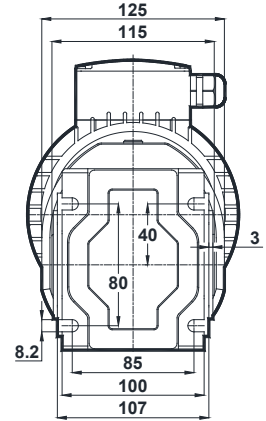

**Klemens Pozisyonları**  
Terminal Box Positions  
Klemmenkasten Positionen

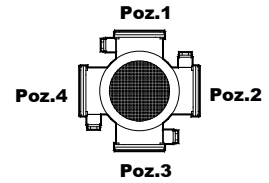

63-71-80-90  
Tip / Type / Typ

KR002.01  
KR003.01

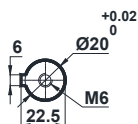
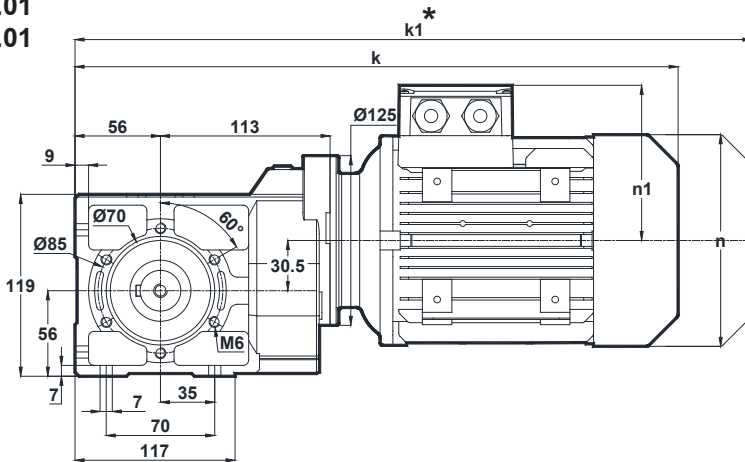

	63	71	80	90S	90L
k	366	395	429	468	468
k1	427	486	522	572.5	572.5
n	121	137	155	176	176
n1	97	112	121	132	132

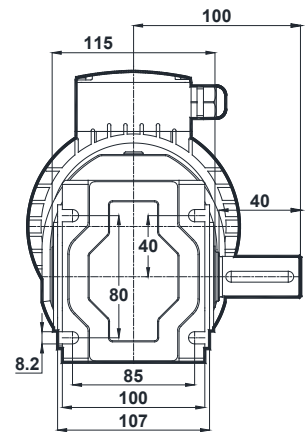

\* "k1" Ölçüsü frenli redüktörlere aittir.  
Dimension "k1" is for motors with brake.  
Maße "k1" ist für Bremsenmotoren.

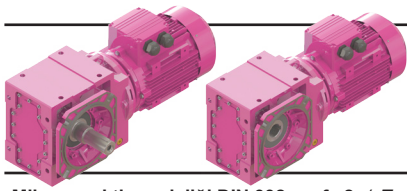

# Ölçü Sayfaları

## Dimension Pages

### Abmessungsseiten

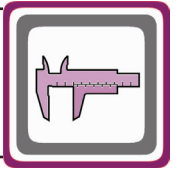

-Mil ucu çektirme deliği DIN 332 sayfa 2 / Tapped center hole to DIN 332, sheet 2 / Zentrierung mit Gewinde DIN 332, Blatt 2

KR002.02  
KR003.02

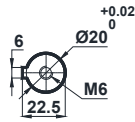
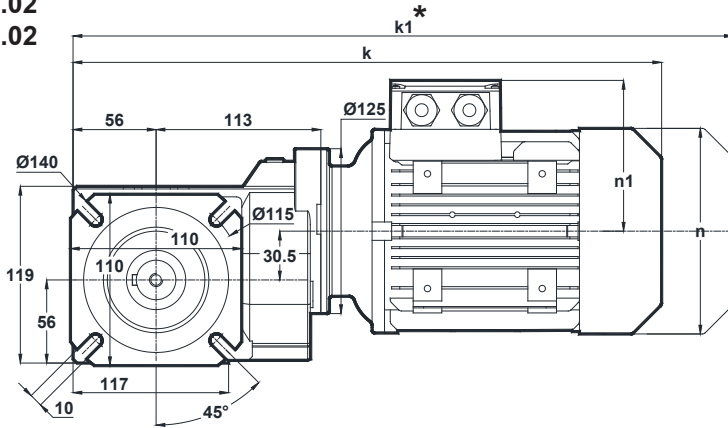

	63	71	80	90S	90L
k	366	395	429	468	468
k1	427	486	522	572.5	572.5
n	121	137	155	176	176
n1	97	112	121	132	132

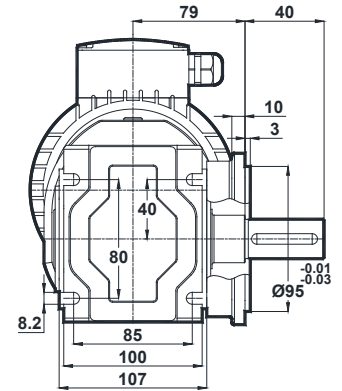

Klemens Pozisyonları  
Terminal Box Positions  
Klemmenkasten Positionen

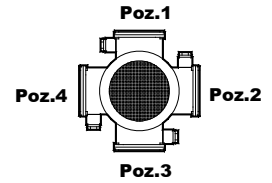

63-71-80-90  
Tip / Type / Typ

KR002.03  
KR003.03

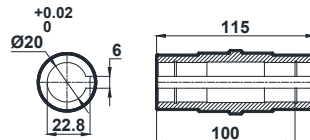
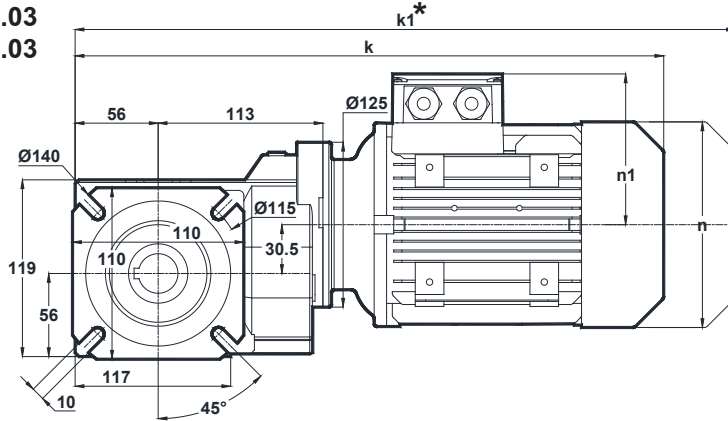

	63	71	80	90S	90L
k	366	395	429	468	468
k1	427	486	522	572.5	572.5
n	121	137	155	176	176
n1	97	112	121	132	132

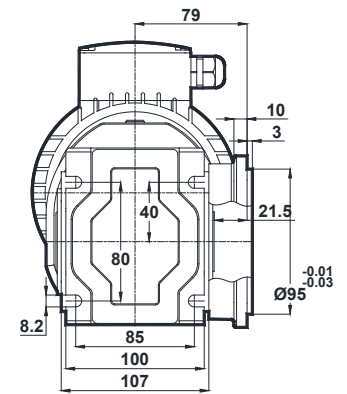

\* "k1" Ölçüsü frenli redüktörlere aittir.  
Dimension "k1" is for motors with brake.  
Maße "k1" ist für Bremsenmotoren.

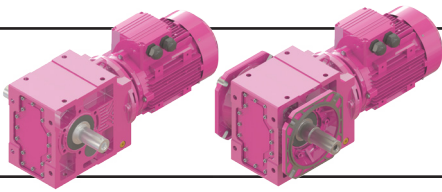

# Ölçü Sayfaları

## Dimension Pages

### Abmessungsseiten

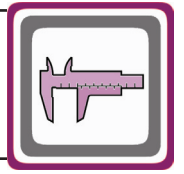

-Mil ucu çektirme deliği DIN 332 sayfa 2 / Tapped center hole to DIN 332, sheet 2 / Zentrierung mit Gewinde DIN 332, Blatt 2

KR002.04  
KR003.04

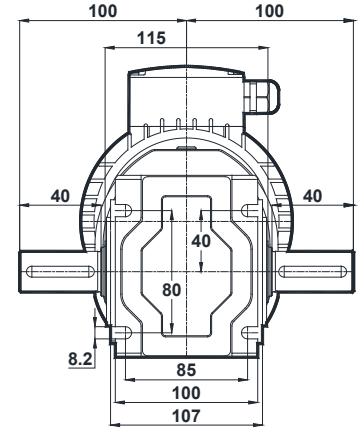
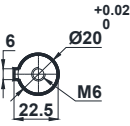
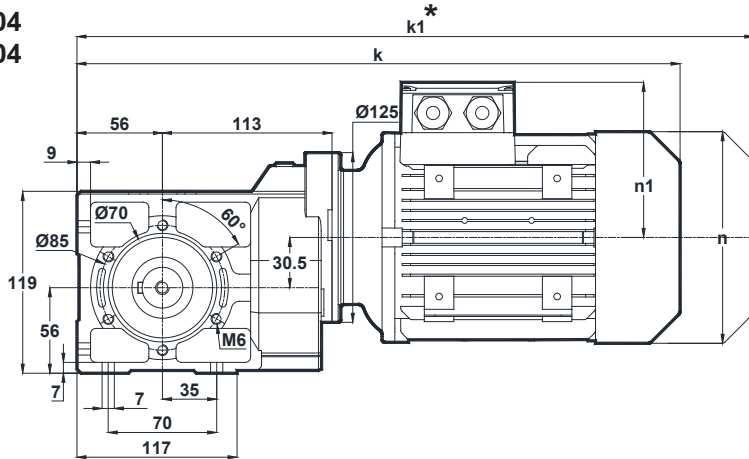

**Klemens Pozisyonları**  
Terminal Box Positions  
Klemmenkasten Positionen

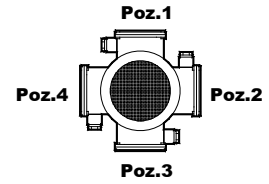

63-71-80-90  
Tip / Type / Typ

	63	71	80	90S	90L
k	366	395	429	468	468
k1	427	486	522	572.5	572.5
n	121	137	155	176	176
n1	97	112	121	132	132

KR002.05  
KR003.05

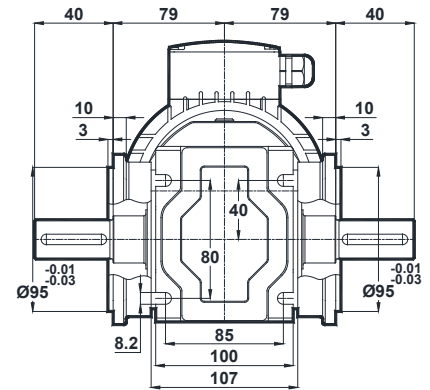
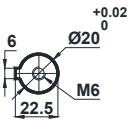
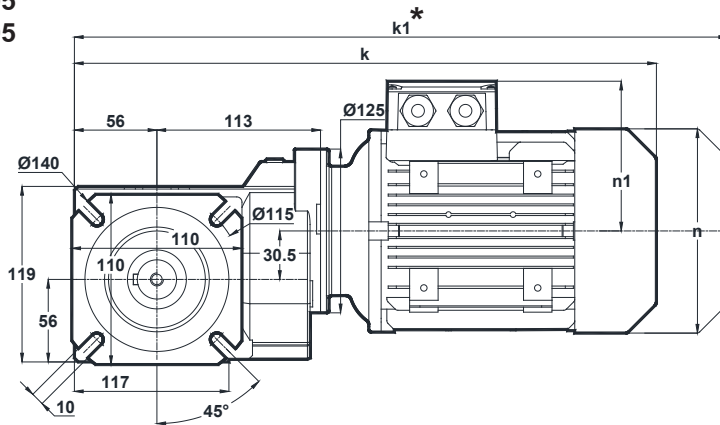

	63	71	80	90S	90L
k	366	395	429	468	468
k1	427	486	522	572.5	572.5
n	121	137	155	176	176
n1	97	112	121	132	132

\* "k1" Ölçüsü frenli redüktörlere aittir.  
Dimension "k1" is for motors with brake.  
Maße "k1" ist für Bremsenmotoren.



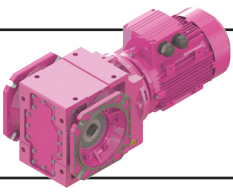

# Ölçü Sayfaları Dimension Pages Abmessungsseiten

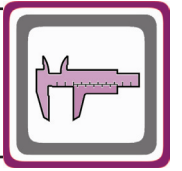

-Mil ucu çektirme deliği DIN 332 sayfa 2 / Tapped center hole to DIN 332, sheet 2 / Zentrierung mit Gewinde DIN 332, Blatt 2

KR002.08  
KR003.08

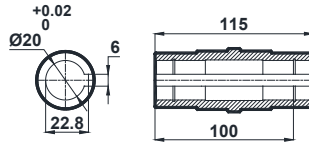
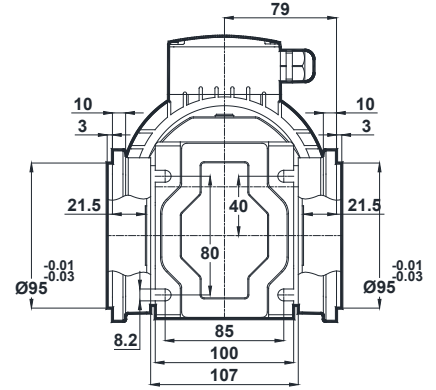
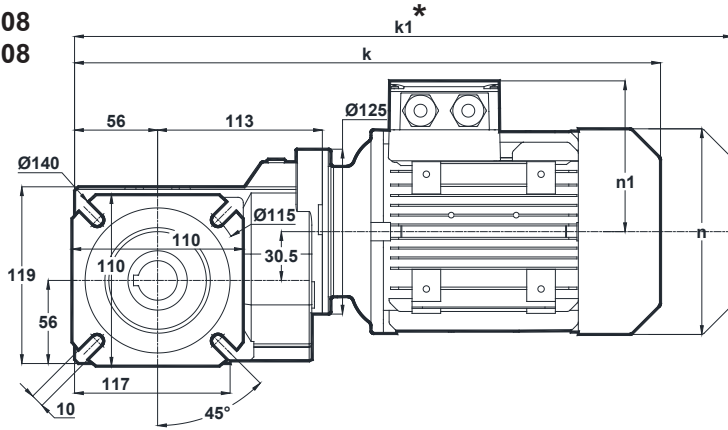

Klemens Pozisyonları  
Terminal Box Positions  
Klemmenkasten Positionen

	63	71	80	90S	90L
k	366	395	429	468	468
k1	427	486	522	572.5	572.5
n	121	137	155	176	176
n1	97	112	121	132	132

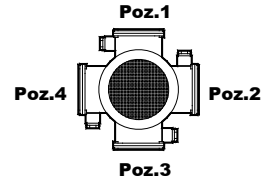

63-71-80-90  
Tip / Type / Typ

\* "k1" Ölçüsü frenli redüktörlere aittir.  
Dimension "k1" is for motors with brake.  
Maße "k1" ist für Bremsenmotoren.

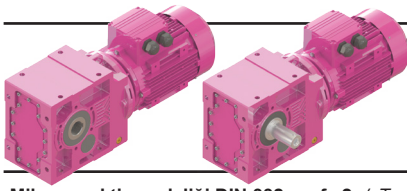

# Ölçü Sayfaları

## Dimension Pages

### Abmessungsseiten

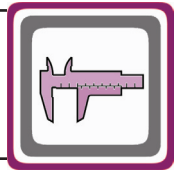

-Mil ucu çektirme deliği DIN 332 sayfa 2 / Tapped center hole to DIN 332, sheet 2 / Zentrierung mit Gewinde DIN 332, Blatt 2

KR102.00  
KR103.00

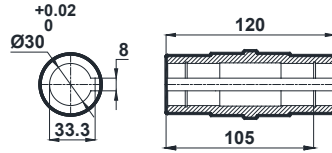
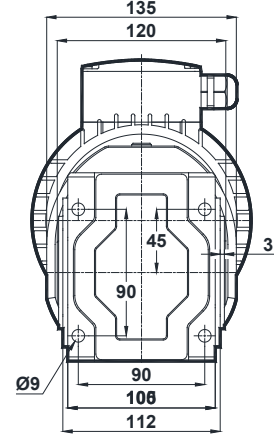
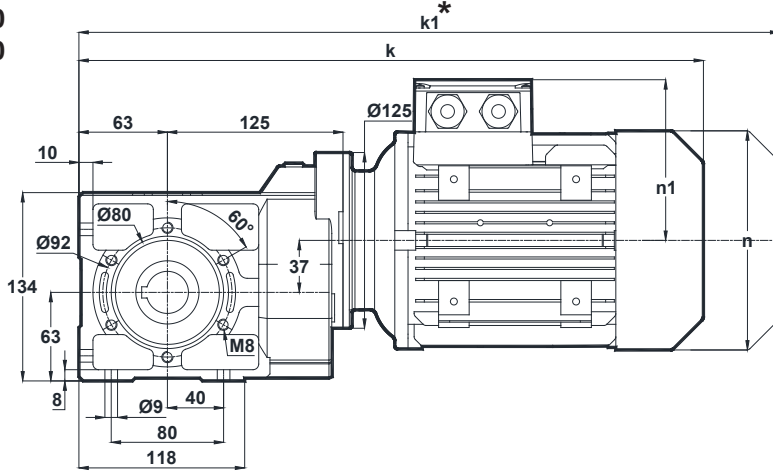

	63	71	80	90S	90L
k	385	414	448	487	487
k1	446	505	541	591.5	591.5
n	121	137	155	176	176
n1	97	112	121	132	132

Klemens Pozisyonları  
Terminal Box Positions  
Klemmenkasten Positionen

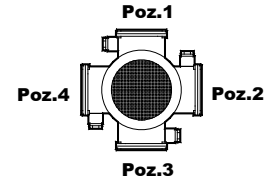

63-71-80-90  
Tip / Type / Typ

KR102.01  
KR103.01

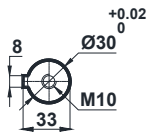
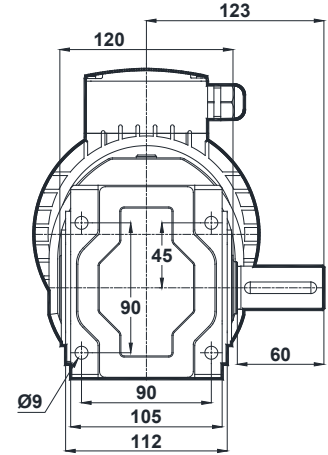
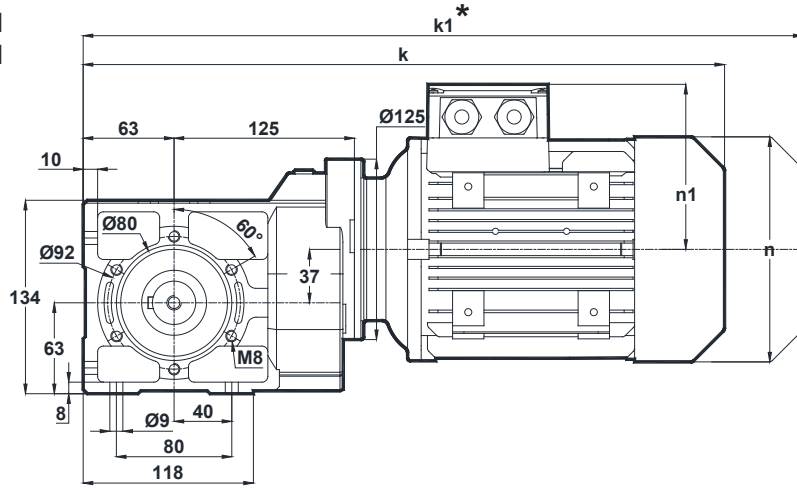

	63	71	80	90S	90L
k	385	414	448	487	487
k1	446	505	541	591.5	591.5
n	121	137	155	176	176
n1	97	112	121	132	132

\* "k1" Ölçüsü frenli redüktörlere aittir.  
Dimension "k1" is for motors with brake.  
Maße "k1" ist für Bremsenmotoren.

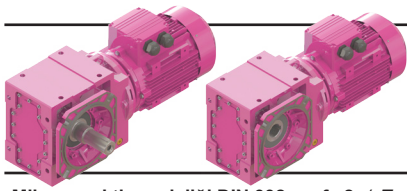

# Ölçü Sayfaları

## Dimension Pages

### Abmessungsseiten

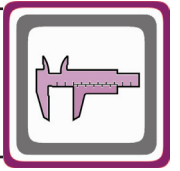

-Mil ucu çektirme deliği DIN 332 sayfa 2 / Tapped center hole to DIN 332, sheet 2 / Zentrierung mit Gewinde DIN 332, Blatt 2

KR102.02  
KR103.02

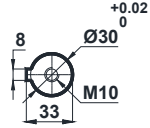
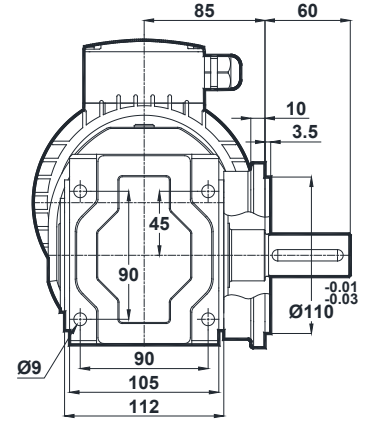
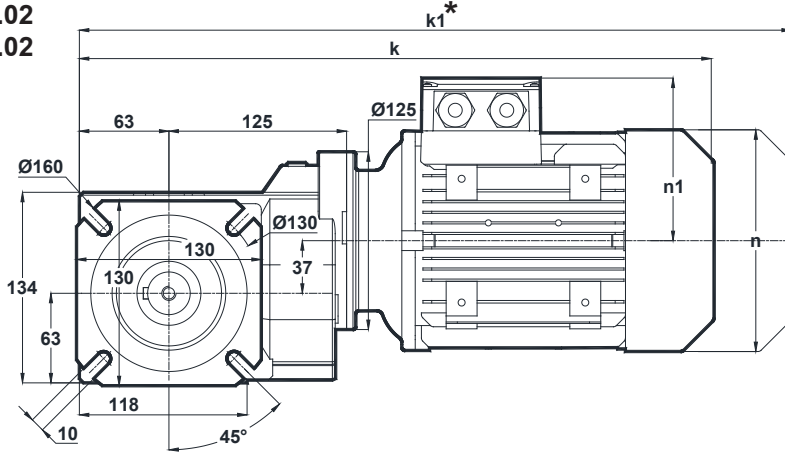

Klemens Pozisyonları  
Terminal Box Positions  
Klemmenkasten Positionen

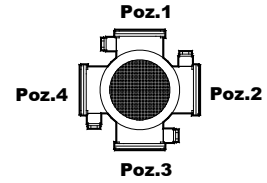

63-71-80-90  
Tip / Type / Typ

	63	71	80	90S	90L
k	385	414	448	487	487
k1	446	505	541	591.5	591.5
n	121	137	155	176	176
n1	97	112	121	132	132

KR102.03  
KR103.03

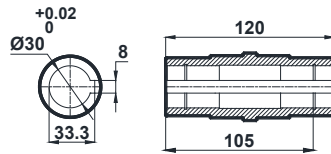
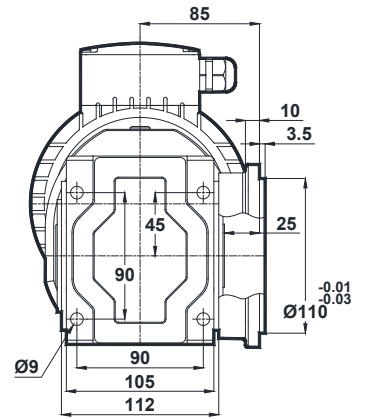
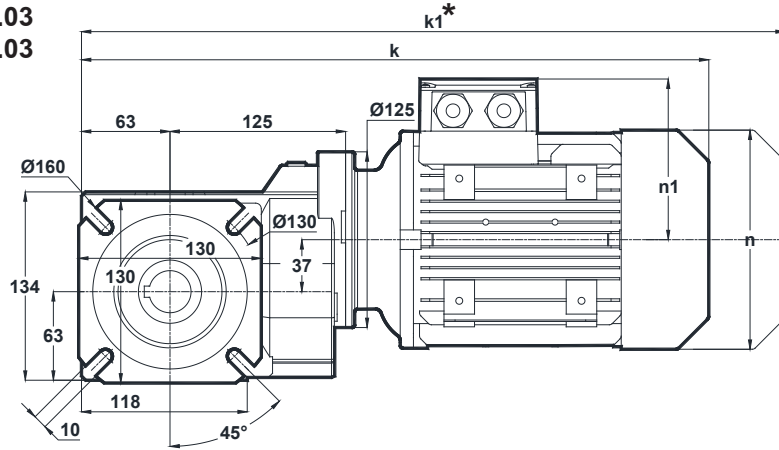

	63	71	80	90S	90L
k	385	414	448	487	487
k1	446	505	541	591.5	591.5
n	121	137	155	176	176
n1	97	112	121	132	132

\* "k1" Ölçüsü frenli redüktörlere aittir.  
Dimension "k1" is for motors with brake.  
Maße "k1" ist für Bremsenmotoren.

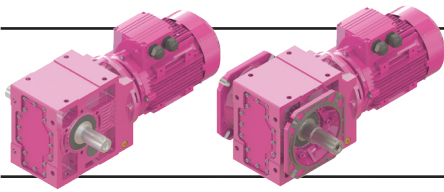

# Ölçü Sayfaları

## Dimension Pages

### Abmessungsseiten

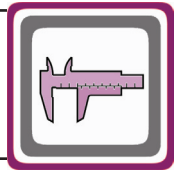

-Mil ucu çektirme deliği DIN 332 sayfa 2 / Tapped center hole to DIN 332, sheet 2 / Zentrierung mit Gewinde DIN 332, Blatt 2

KR102.04  
KR103.04

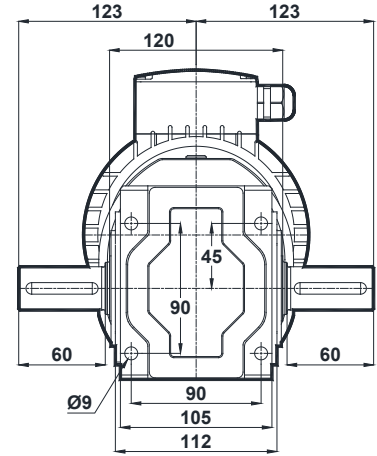
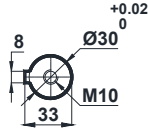
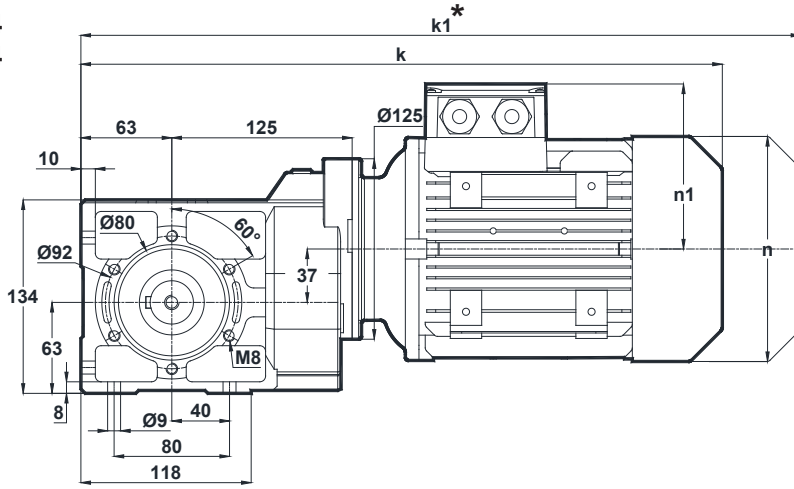

**Klemens Pozisyonları**  
Terminal Box Positions  
Klemmenkasten Positionen

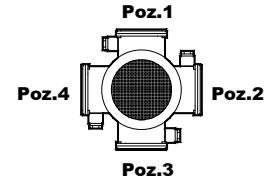

63-71-80-90  
Tip / Type / Typ

	63	71	80	90S	90L
k	385	414	448	487	487
k1	446	505	541	591.5	591.5
n	121	137	155	176	176
n1	97	112	121	132	132

KR102.05  
KR103.05

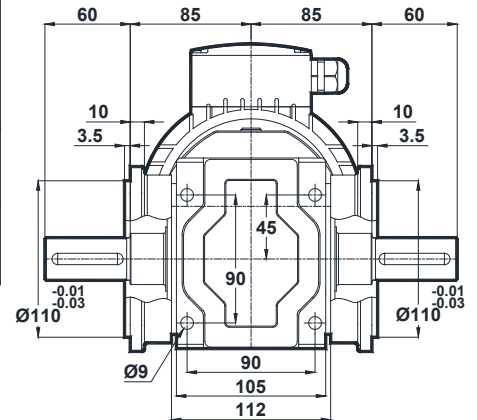
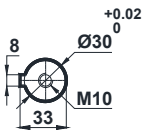
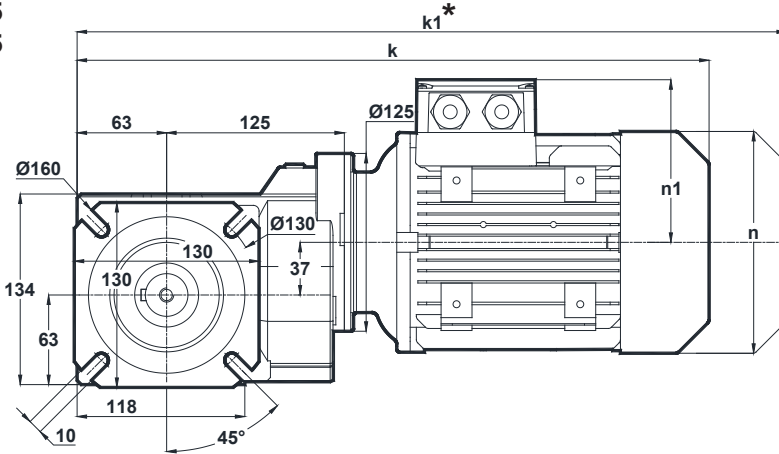

	63	71	80	90S	90L
k	385	414	448	487	487
k1	446	505	541	591.5	591.5
n	121	137	155	176	176
n1	97	112	121	132	132

\* "k1" Ölçüsü frenli redüktörlere aittir.  
Dimension "k1" is for motors with brake.  
Maße "k1" ist für Bremsenmotoren.

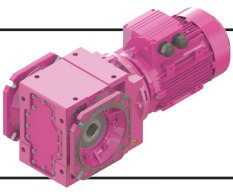

# Ölçü Sayfaları Dimension Pages Abmessungenseiten

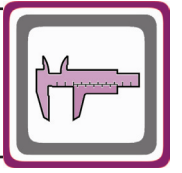

-Mil ucu çektirme deliği DIN 332 sayfa 2 / Tapped center hole to DIN 332, sheet 2 / Zentrierung mit Gewinde DIN 332, Blatt 2

KR102.08  
KR103.08

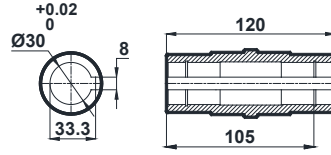
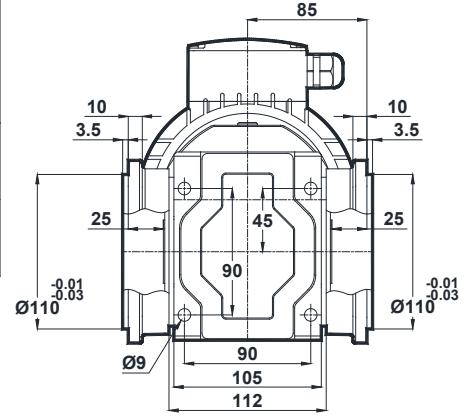
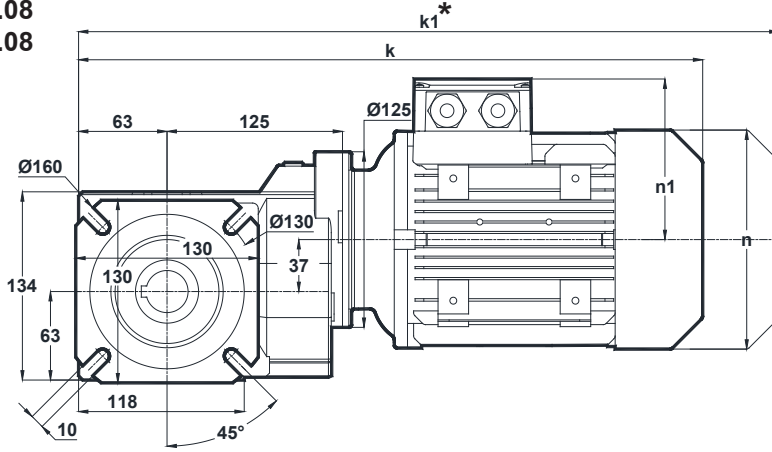

Klemens Pozisyonları  
Terminal Box Positions  
Klemmenkasten Positionen

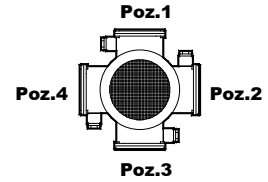

63-71-80-90  
Tip / Type / Typ

	63	71	80	90S	90L
k	385	414	448	487	487
k1	446	505	541	591.5	591.5
n	121	137	155	176	176
n1	97	112	121	132	132

\* "k1" Ölçüsü frenli redüktörlere aittir.  
Dimension "k1" is for motors with brake.  
Maße "k1" ist für Bremsenmotoren.

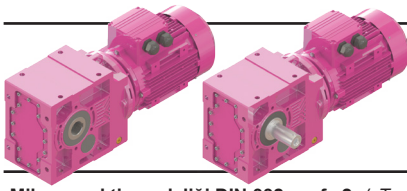

# Ölçü Sayfaları

## Dimension Pages

### Abmessungsseiten

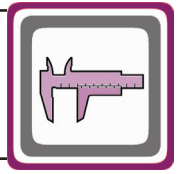

-Mil ucu çektirme deliği DIN 332 sayfa 2 / Tapped center hole to DIN 332, sheet 2 / Zentrierung mit Gewinde DIN 332, Blatt 2

KR202.00  
KR203.00

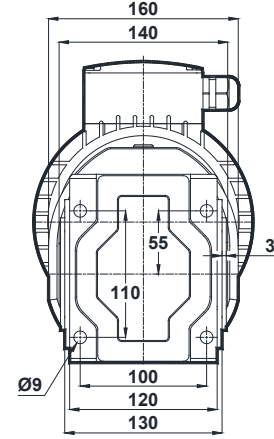
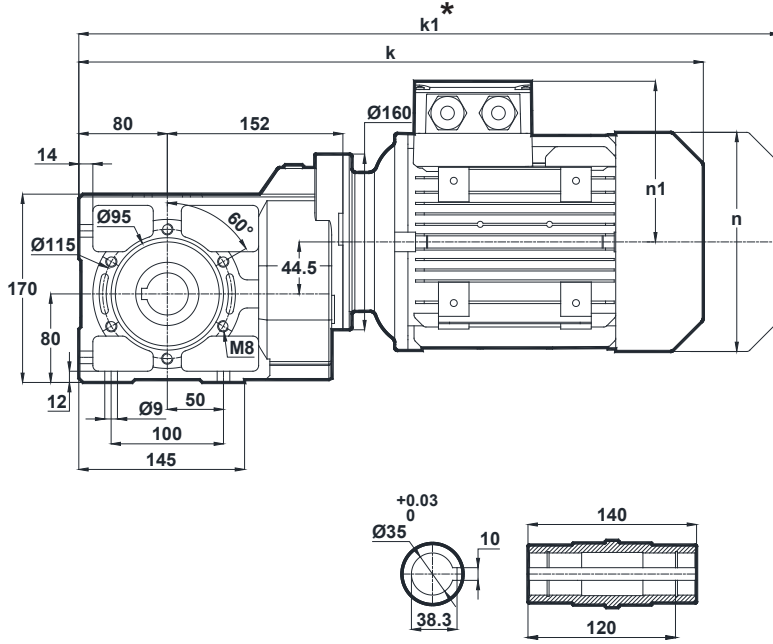

**Klemens Pozisyonları**  
Terminal Box Positions  
Klemmenkasten Positionen

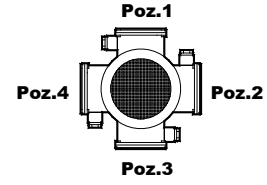

63-71-80-90-100-112  
Tip / Type / Typ

	63	71	80	90S	90L	100L	112M
k	425	453	487	526	526	574	598
k1	486	544	580	630.5	630.5	639.5	702.5
n	121	137	155	176	176	193	215
n1	97	112	121	132	132	147	158

KR202.01  
KR203.01

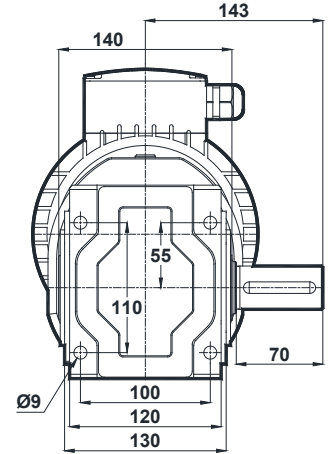
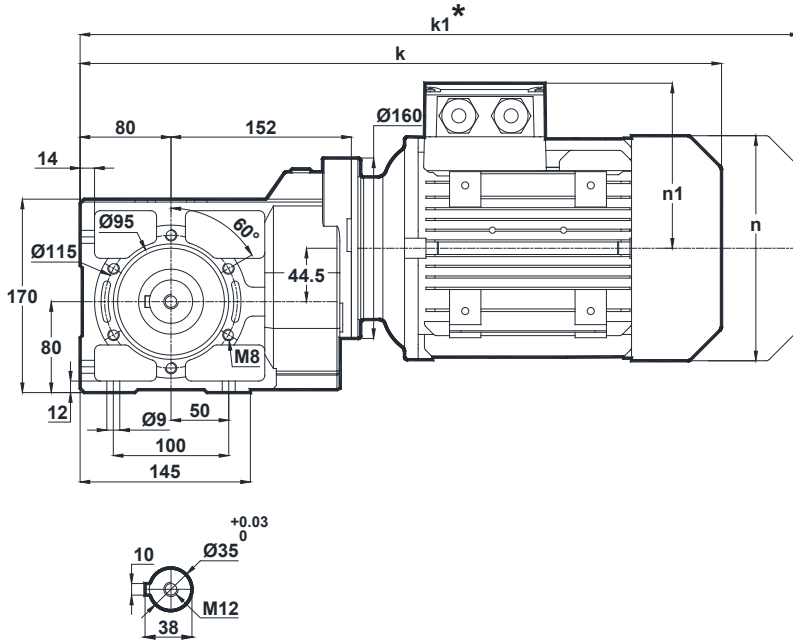

	63	71	80	90S	90L	100L	112M
k	425	453	487	526	526	574	598
k1	486	544	580	630.5	630.5	639.5	702.5
n	121	137	155	176	176	193	215
n1	97	112	121	132	132	147	158

\* "k1" Ölçüsü frenli redüktörlere aittir.  
Dimension "k1" is for motors with brake.  
Maße "k1" ist für Bremsenmotoren.

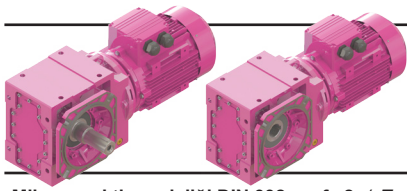

# Ölçü Sayfaları

## Dimension Pages

### Abmessungsseiten

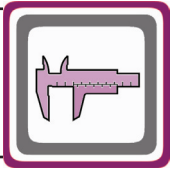

-Mil ucu çektirme deliği DIN 332 sayfa 2 / Tapped center hole to DIN 332, sheet 2 / Zentrierung mit Gewinde DIN 332, Blatt 2

KR202.02  
KR203.02

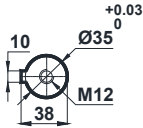
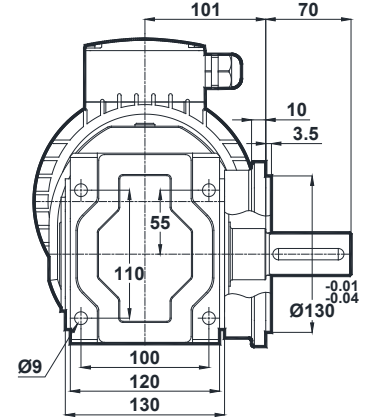
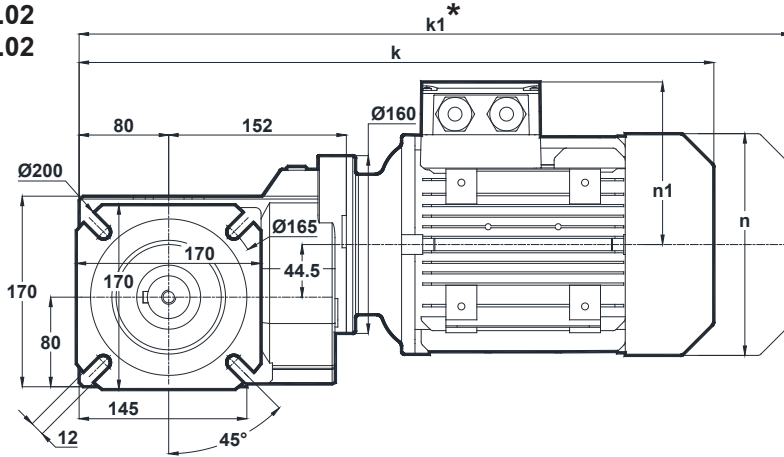

Klemens Pozisyonları  
Terminal Box Positions  
Klemmenkasten Positionen

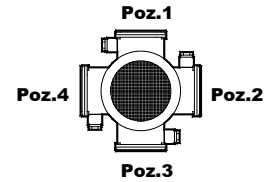

63-71-80-90-100-112  
Tip / Type / Typ

	63	71	80	90S	90L	100L	112M
k	425	453	487	526	526	574	598
k1	486	544	580	630.5	630.5	639.5	702.5
n	121	137	155	176	176	193	215
n1	97	112	121	132	132	147	158

KR202.03  
KR203.03

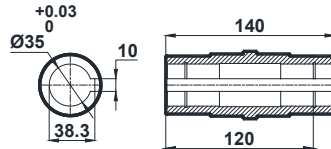
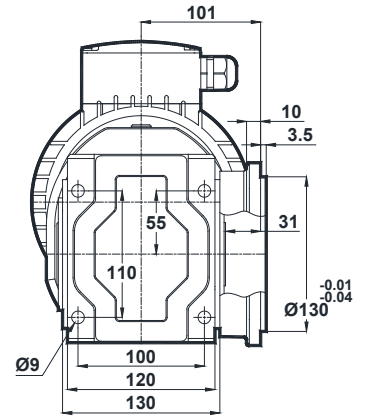
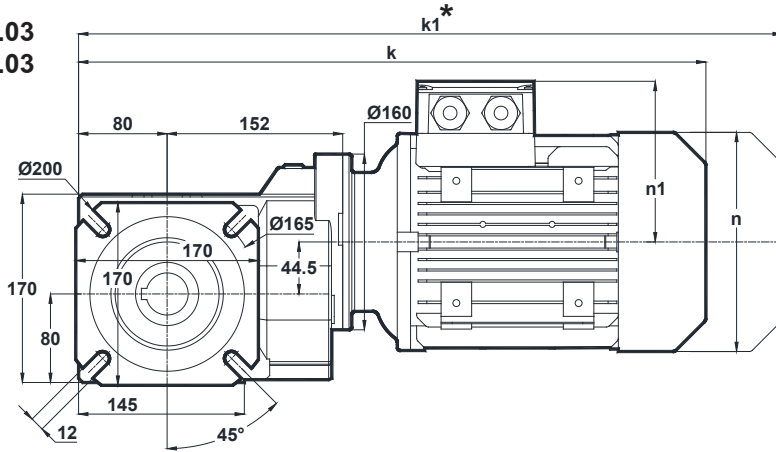

	63	71	80	90S	90L	100L	112M
k	425	453	487	526	526	574	598
k1	486	544	580	630.5	630.5	639.5	702.5
n	121	137	155	176	176	193	215
n1	97	112	121	132	132	147	158

\* "k1" Ölçüsü frenli redüktörlere aittir.  
Dimension "k1" is for motors with brake.  
Maße "k1" ist für Bremsenmotoren.

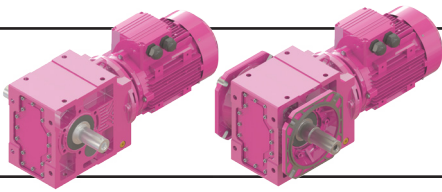

# Ölçü Sayfaları

## Dimension Pages

### Abmessungsseiten

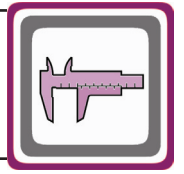

-Mil ucu çektirme deliği DIN 332 sayfa 2 / Tapped center hole to DIN 332, sheet 2 / Zentrierung mit Gewinde DIN 332, Blatt 2

KR202.04  
KR203.04

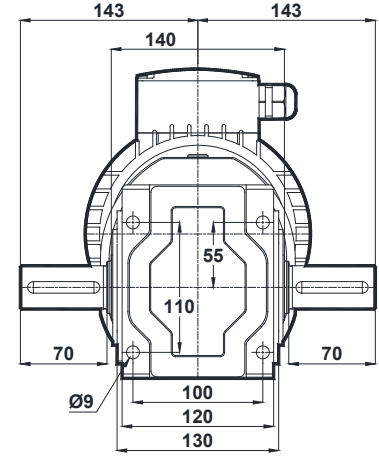
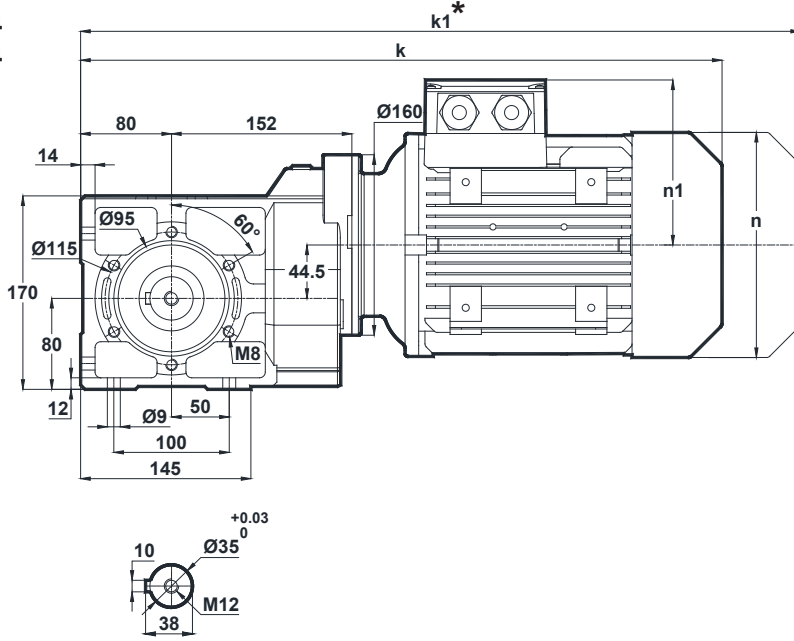

Klemens Pozisyonları  
Terminal Box Positions  
Klemmenkasten Positionen

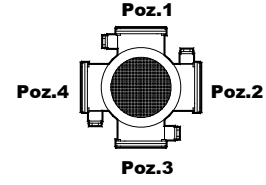

63-71-80-90-100-112  
Tip / Type / Typ

	63	71	80	90S	90L	100L	112M
k	425	453	487	526	526	574	598
k1	486	544	580	630.5	630.5	639.5	702.5
n	121	137	155	176	176	193	215
n1	97	112	121	132	132	147	158

KR202.05  
KR203.05

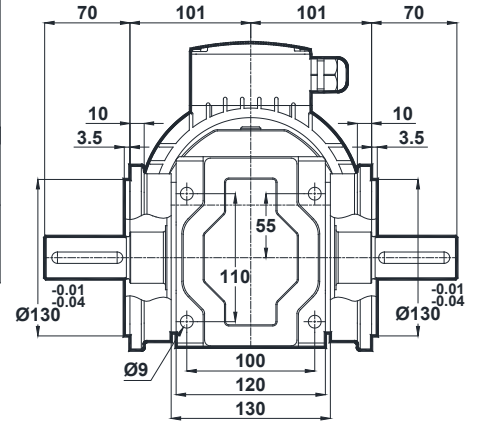
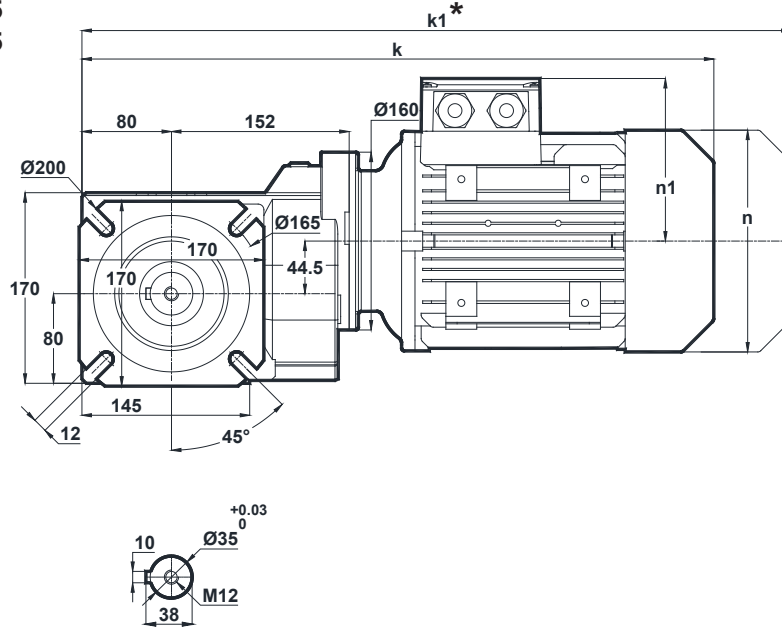

	63	71	80	90S	90L	100L	112M
k	425	453	487	526	526	574	598
k1	486	544	580	630.5	630.5	639.5	702.5
n	121	137	155	176	176	193	215
n1	97	112	121	132	132	147	158

\* "k1" Ölçüsü frenli redüktörlere aittir.  
Dimension "k1" is for motors with brake.  
Maße "k1" ist für Bremsenmotoren.



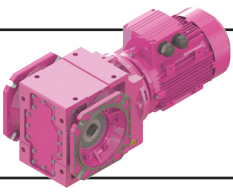

# Ölçü Sayfaları Dimension Pages Abmessungsseiten

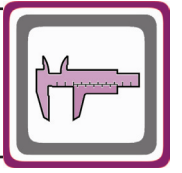

-Mil ucu çektirme deliği DIN 332 sayfa 2 / Tapped center hole to DIN 332, sheet 2 / Zentrierung mit Gewinde DIN 332, Blatt 2

KR202.08  
KR203.08

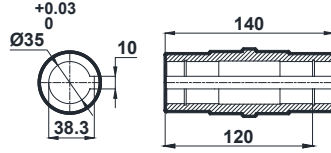
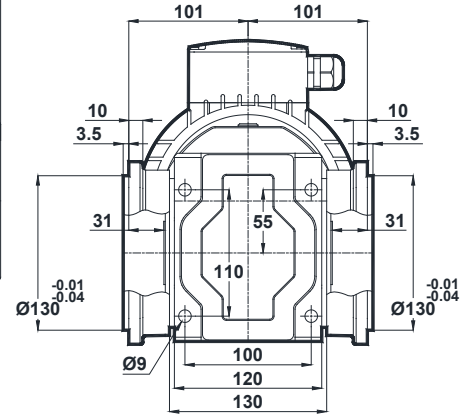
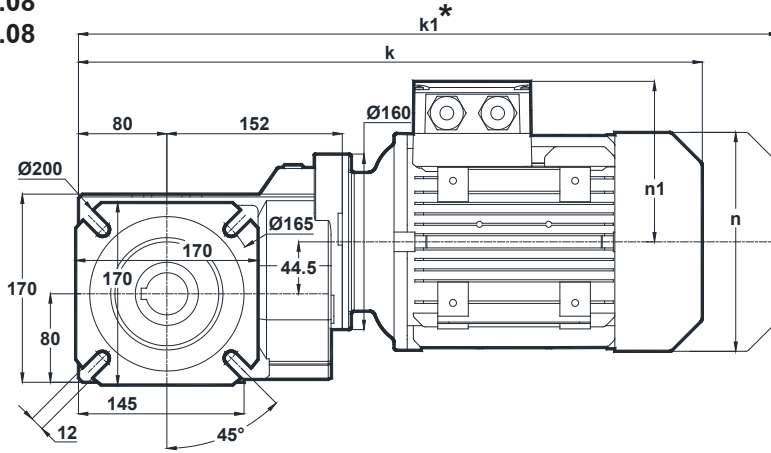

Klemens Pozisyonları  
Terminal Box Positions  
Klemmenkasten Positionen

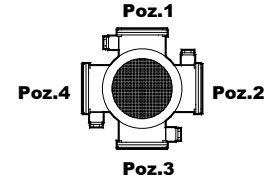

63-71-80-90-100-112  
Tip / Type / Typ

	63	71	80	90S	90L	100L	112M
k	425	453	487	526	526	574	598
k1	486	544	580	630.5	630.5	639.5	702.5
n	121	137	155	176	176	193	215
n1	97	112	121	132	132	147	158

\* "k1" Ölçüsü frenli redüktörlere aittir.  
Dimension "k1" is for motors with brake.  
Maße "k1" ist für Bremsenmotoren.

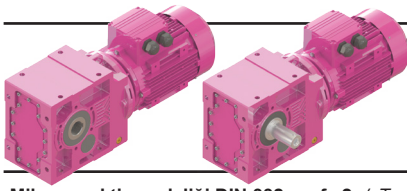

# Ölçü Sayfaları

## Dimension Pages

### Abmessungsseiten

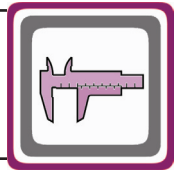

-Mil ucu çektirme deliği DIN 332 sayfa 2 / Tapped center hole to DIN 332, sheet 2 / Zentrierung mit Gewinde DIN 332, Blatt 2

#### KR273.00

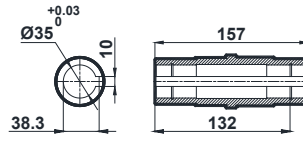
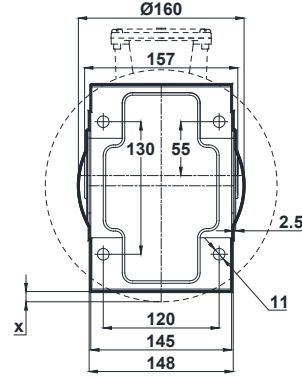
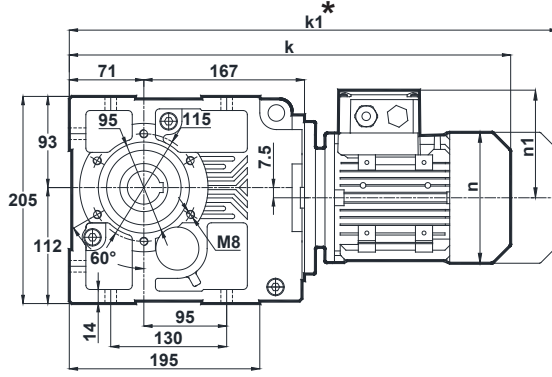

x: Motor Ayak bağlantı yüzeyinin altında ise  
x: If Motor is lower than foot mounting plane  
x: Wenn der Motor unter der Fußmontageebene ist

Klemens Pozisyonları  
Terminal Box Positions  
Klemmenkasten Positionen

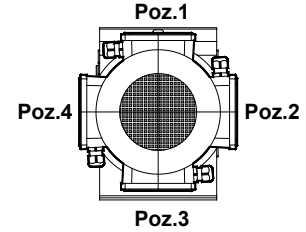

63-71- 80-90-100-112  
Tip / Type / Typ

	63	71	80	90S	90L	100L	112M
k	431	459	493	532	532	580	604
k1	492	550	586	636.5	636.5	699.5	708.5
n	121	137	155	176	176	193	215
n1	97	112	121	132	132	147	158
x	-	-	-	-	-	-	3

#### KR273.01

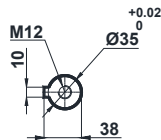
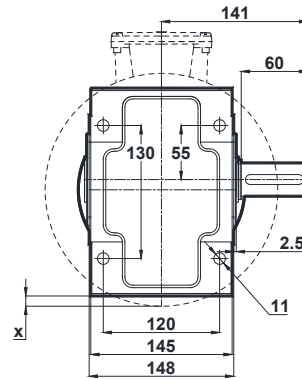
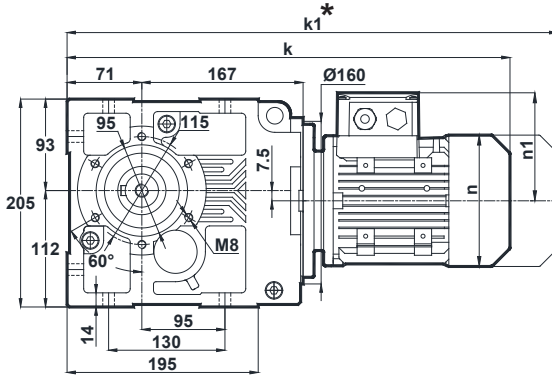

x: Motor Ayak bağlantı yüzeyinin altında ise  
x: If Motor is lower than foot mounting plane  
x: Wenn der Motor unter der Fußmontageebene ist

	63	71	80	90S	90L	100L	112M
k	431	459	493	532	532	580	604
k1	492	550	586	636.5	636.5	699.5	708.5
n	121	137	155	176	176	193	215
n1	97	112	121	132	132	147	158
x	-	-	-	-	-	-	3

\* " k1 " Ölçüsü frenli redüktörlere aittir.  
Dimension " k1 " is for motors with brake.  
Maße " k1 " ist für Bremsenmotoren.

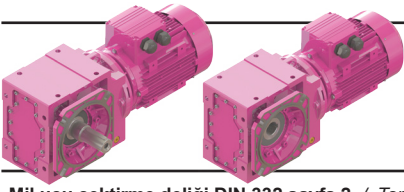

# Ölçü Sayfaları

## Dimension Pages

### Abmessungsseiten

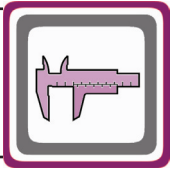

-Mil ucu çekirme deliği DIN 332 sayfa 2 / Tapped center hole to DIN 332, sheet 2 / Zentrierung mit Gewinde DIN 332, Blatt 2

#### KR273.02

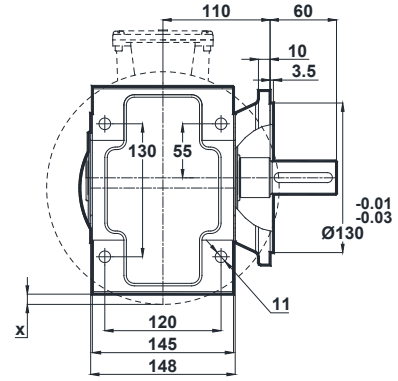
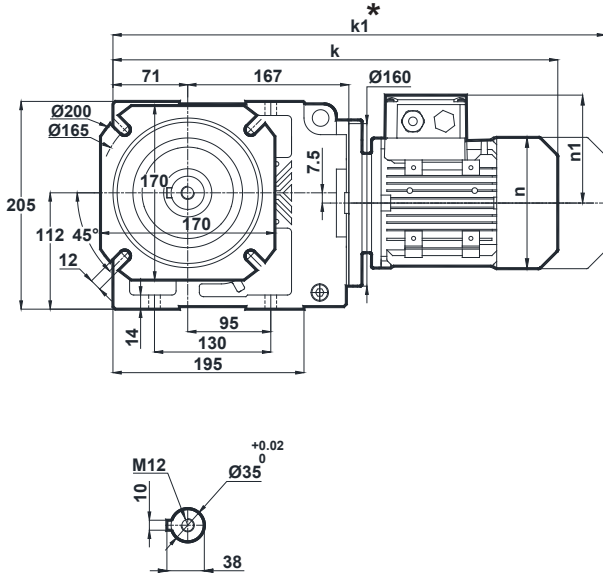

x: Motor Ayak bağlantı yüzeyinin altında ise  
x: If Motor is lower than foot mounting plane  
x: Wenn der Motor unter der Fußmontageebene ist

Klemens Pozisyonları  
Terminal Box Positions  
Klemmenkasten Positionen

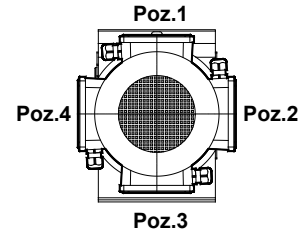

63-71-80-90-100-112  
Tip / Type / Typ

	63	71	80	90S	90L	100L	112M
k	431	459	493	532	532	580	604
k1	492	550	586	636.5	636.5	699.5	708.5
n	121	137	155	176	176	193	215
n1	97	112	121	132	132	147	158
x	-	-	-	-	-	-	3

#### KR273.03

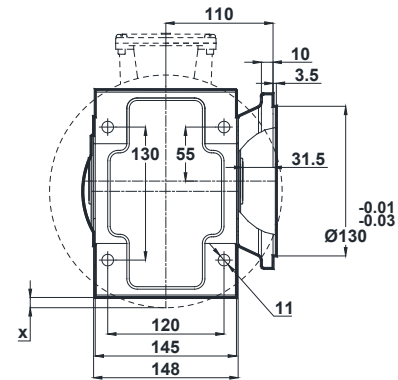
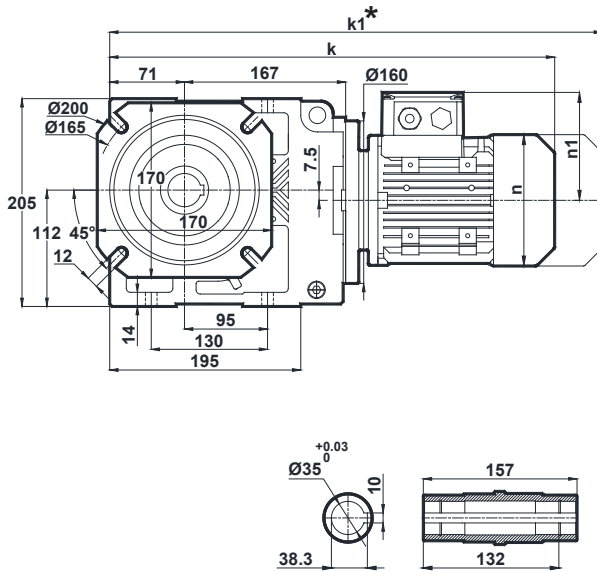

x: Motor Ayak bağlantı yüzeyinin altında ise  
x: If Motor is lower than foot mounting plane  
x: Wenn der Motor unter der Fußmontageebene ist

	63	71	80	90S	90L	100L	112M
k	431	459	493	532	532	580	604
k1	492	550	586	636.5	636.5	699.5	708.5
n	121	137	155	176	176	193	215
n1	97	112	121	132	132	147	158
x	-	-	-	-	-	-	3

\* "k1" Ölçüsü frenli redüktörlere aittir.  
Dimension "k1" is for motors with brake.  
Maße "k1" ist für Bremsenmotoren.

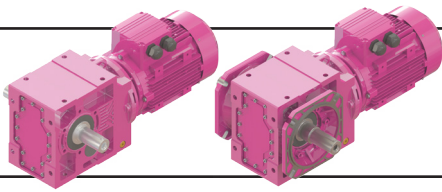

# Ölçü Sayfaları

## Dimension Pages

### Abmessungsseiten

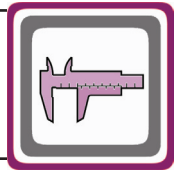

-Mil ucu çektirme deliği DIN 332 sayfa 2 / Tapped center hole to DIN 332, sheet 2 / Zentrierung mit Gewinde DIN 332, Blatt 2

#### KR273.04

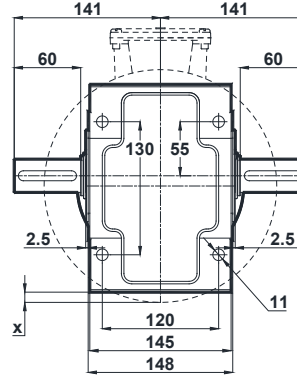
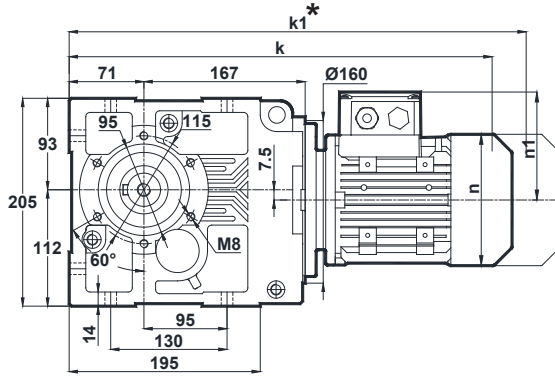

x: Motor Ayak bağlantı yüzeyinin altında ise  
 x: If Motor is lower than foot mounting plane  
 x: Wenn der Motor unter der Fußmontageebene ist

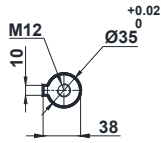

**Klemens Pozisyonları**  
 Terminal Box Positions  
 Klemmenkasten Positionen

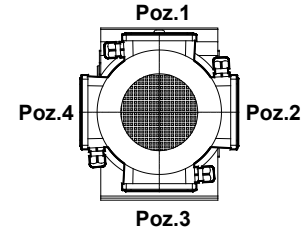

63-71- 80-90-100-112  
 Tip / Type / Typ

	63	71	80	90S	90L	100L	112M
k	431	459	493	532	532	580	604
k1	492	550	586	636.5	636.5	699.5	708.5
n	121	137	155	176	176	193	215
n1	97	112	121	132	132	147	158
x	-	-	-	-	-	-	3

#### KR273.05

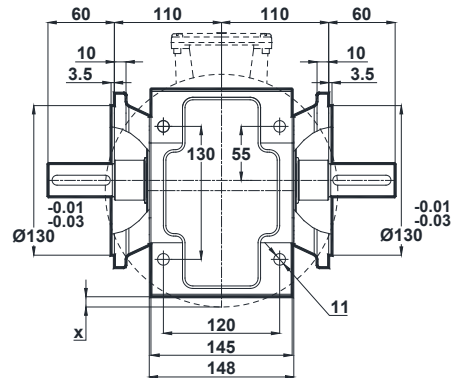
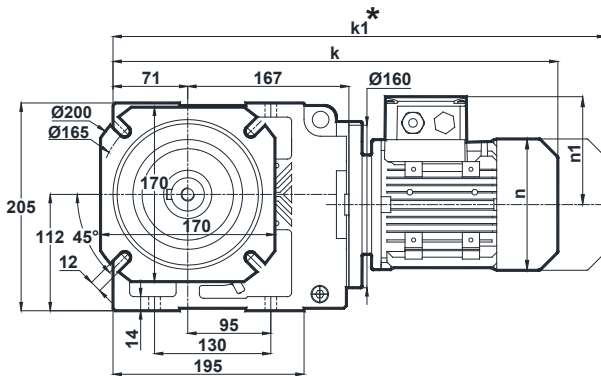

x: Motor Ayak bağlantı yüzeyinin altında ise  
 x: If Motor is lower than foot mounting plane  
 x: Wenn der Motor unter der Fußmontageebene ist

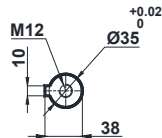

	63	71	80	90S	90L	100L	112M
k	431	459	493	532	532	580	604
k1	492	550	586	636.5	636.5	699.5	708.5
n	121	137	155	176	176	193	215
n1	97	112	121	132	132	147	158
x	-	-	-	-	-	-	3

\* "k1" Ölçüsü frenli redüktörlere aittir.  
 Dimension "k1" is for motors with brake.  
 Maße "k1" ist für Bremsenmotoren.

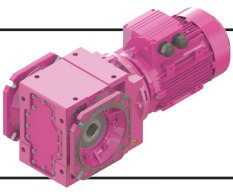

# Ölçü Sayfaları

## Dimension Pages

### Abmessungsseiten

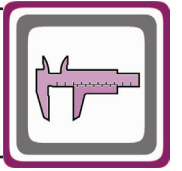

-Mil ucu çektirme deliği DIN 332 sayfa 2 / Tapped center hole to DIN 332, sheet 2 / Zentrierung mit Gewinde DIN 332, Blatt 2

KR273.08

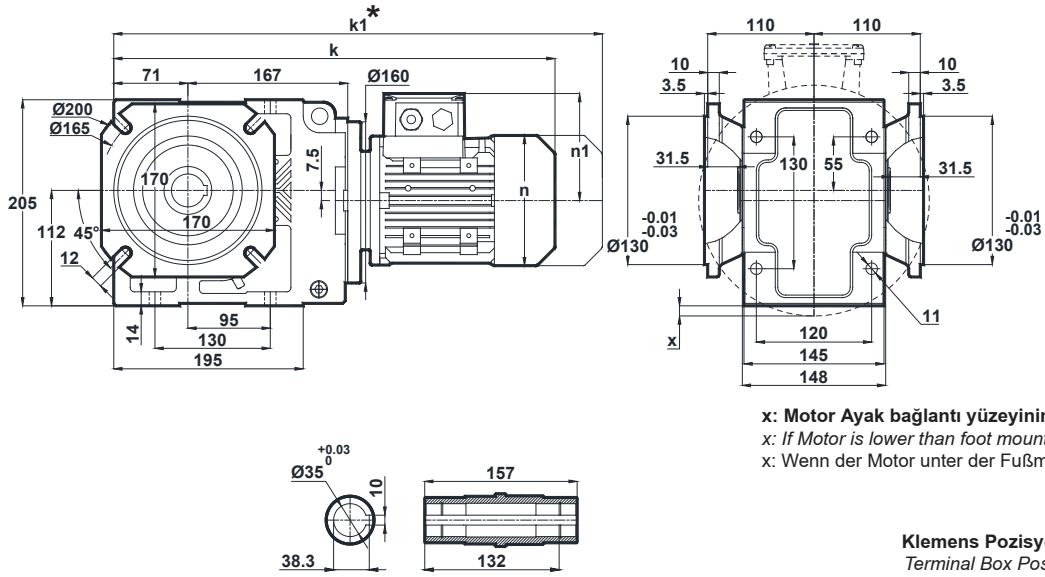

x: Motor Ayak bağlantı yüzeyinin altında ise  
x: If Motor is lower than foot mounting plane  
x: Wenn der Motor unter der Fußmontageebene ist

Klemens Pozisyonları  
Terminal Box Positions  
Klemmenkasten Positionen

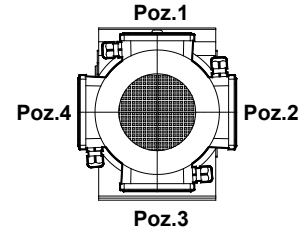

63-71- 80-90-100-112  
Tip / Type / Typ

	63	71	80	90S	90L	100L	112M
k	431	459	493	532	532	580	604
k1	492	550	586	636.5	636.5	699.5	708.5
n	121	137	155	176	176	193	215
n1	97	112	121	132	132	147	158
x	-	-	-	-	-	-	3

\* " k1 " Ölçüsü frenli redüktörlere aittir.  
Dimension " k1 " is for motors with brake.  
Maße " k1 " ist für Bremsenmotoren.

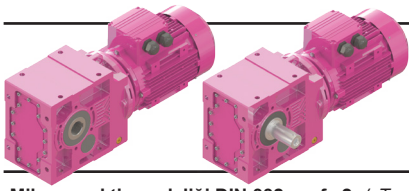

# Ölçü Sayfaları

## Dimension Pages

### Abmessungsseiten

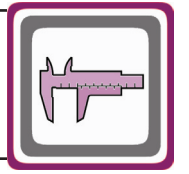

-Mil ucu çektirme deliği DIN 332 sayfa 2 / Tapped center hole to DIN 332, sheet 2 / Zentrierung mit Gewinde DIN 332, Blatt 2

KR275.00  
KR276.00

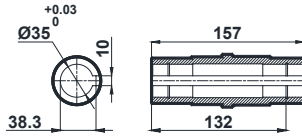
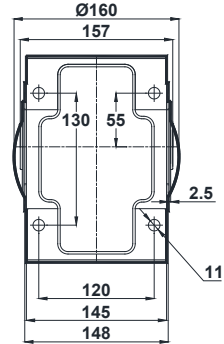
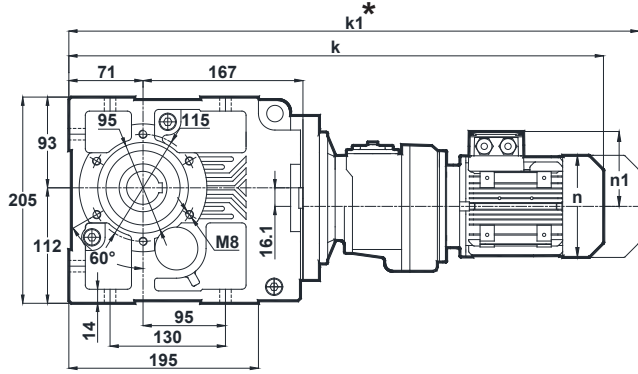

	63	71	80
k	581	610	644
k1	642	701	737
n	121	137	155
n1	97	112	121

**Klemens Pozisyonları**  
Terminal Box Positions  
Klemmenkasten Positionen

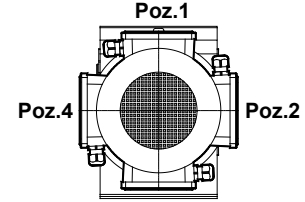

**Poz.3**  
63-71-80  
Tip / Type / Typ

KR275.01  
KR276.01

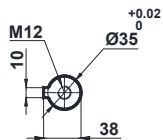
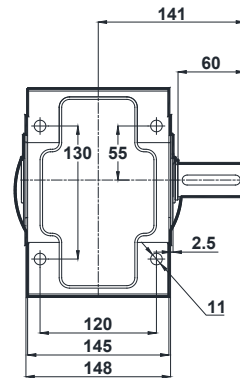
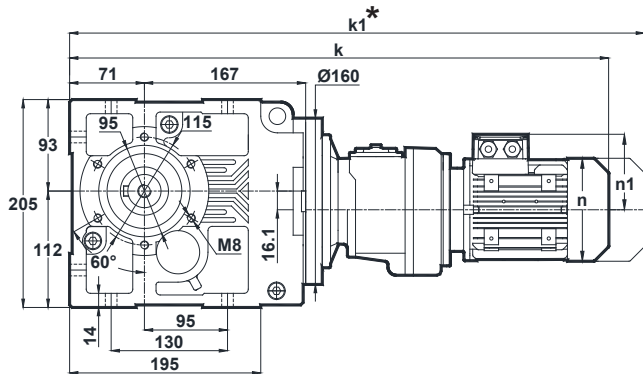

	63	71	80
k	581	610	644
k1	642	701	737
n	121	137	155
n1	97	112	121

\* " k1 " Ölçüsü frenli redüktörlere aittir.  
Dimension " k1 " is for motors with brake.  
Maße " k1 " ist für Bremsenmotoren.

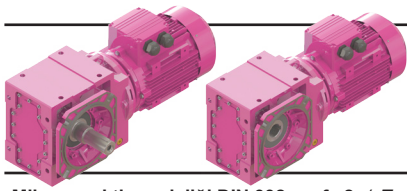

# Ölçü Sayfaları

## Dimension Pages

### Abmessungsseiten

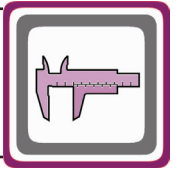

-Mil ucu çektirme deliği DIN 332 sayfa 2 / Tapped center hole to DIN 332, sheet 2 / Zentrierung mit Gewinde DIN 332, Blatt 2

KR275.02  
KR276.02

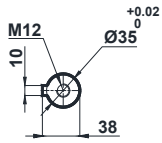
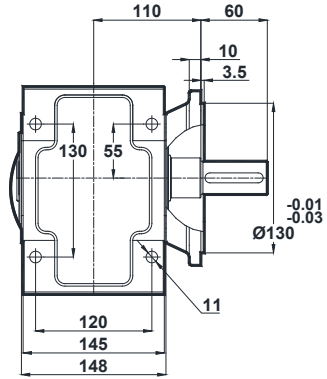
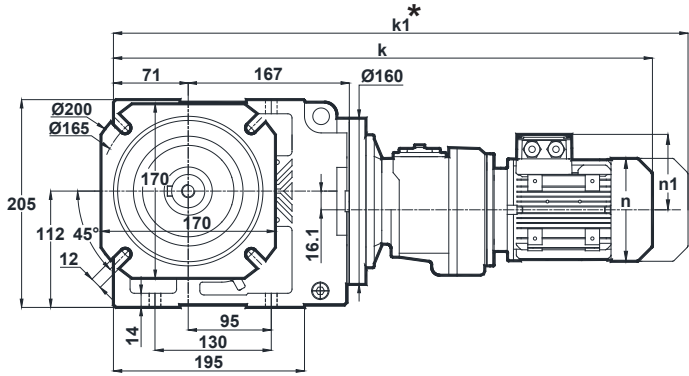

Klemens Pozisyonları  
Terminal Box Positions  
Klemmenkasten Positionen

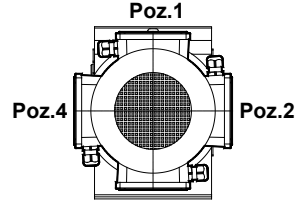

Poz.1  
Poz.2  
Poz.3  
Poz.4  
63-71-80  
Tip / Type / Typ

	63	71	80
k	581	610	644
k1	642	701	737
n	121	137	155
n1	97	112	121

KR275.03  
KR276.03

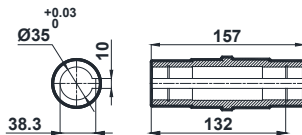
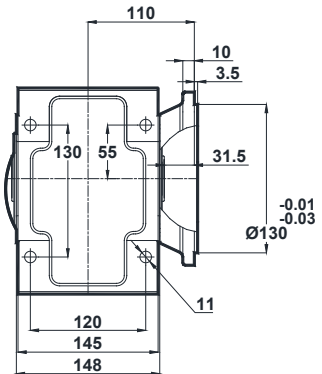
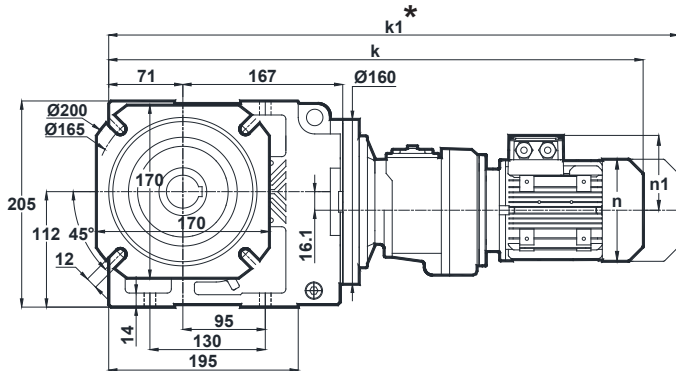

	63	71	80
k	581	610	644
k1	642	701	737
n	121	137	155
n1	97	112	121

\* " k1 " Ölçüsü frenli redüktörlere aittir.  
Dimension " k1 " is for motors with brake.  
Maße " k1 " ist für Bremsenmotoren.

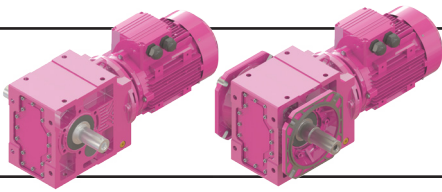

# Ölçü Sayfaları

## Dimension Pages

### Abmessungsseiten

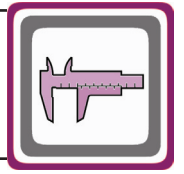

-Mil ucu çektirme deliği DIN 332 sayfa 2 / Tapped center hole to DIN 332, sheet 2 / Zentrierung mit Gewinde DIN 332, Blatt 2

KR275.04  
KR276.04

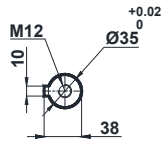
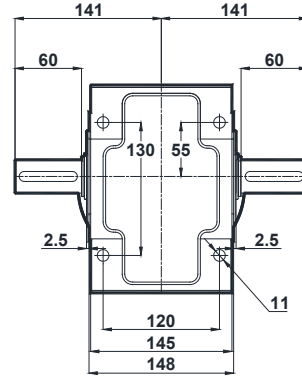
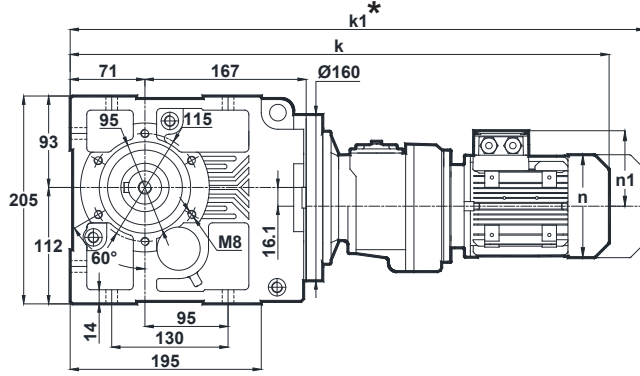

	63	71	80
k	581	610	644
k1	642	701	737
n	121	137	155
n1	97	112	121

**Klemens Pozisyonları**  
Terminal Box Positions  
Klemmenkasten Positionen

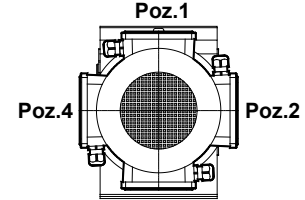

**Poz.3**  
63-71-80  
Tip / Type / Typ

KR275.05  
KR276.05

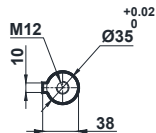
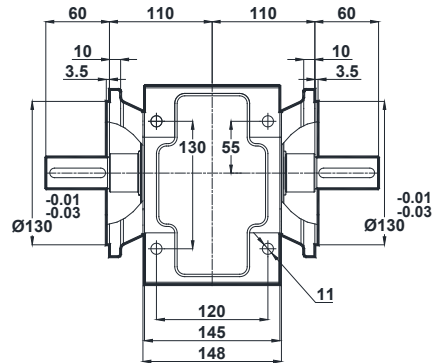
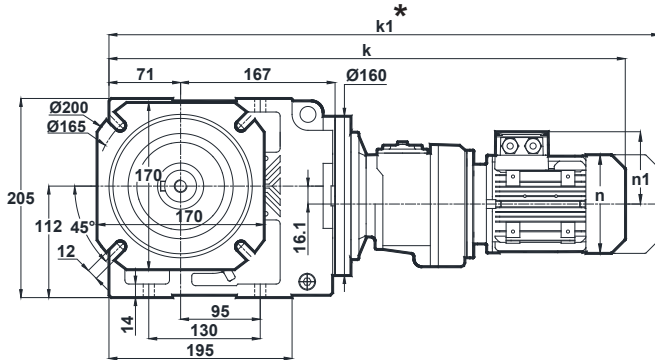

	63	71	80
k	581	610	644
k1	642	701	737
n	121	137	155
n1	97	112	121

\* "k1" Ölçüsü frenli redüktörlere aittir.  
Dimension "k1" is for motors with brake.  
Maße "k1" ist für Bremsenmotoren.



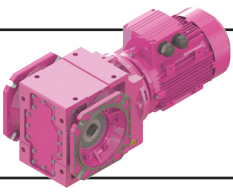

# Ölçü Sayfaları

## Dimension Pages

### Abmessungsseiten

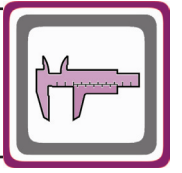

-Mil ucu çektirme deliği DIN 332 sayfa 2 / Tapped center hole to DIN 332, sheet 2 / Zentrierung mit Gewinde DIN 332, Blatt 2

KR275.08  
KR276.08

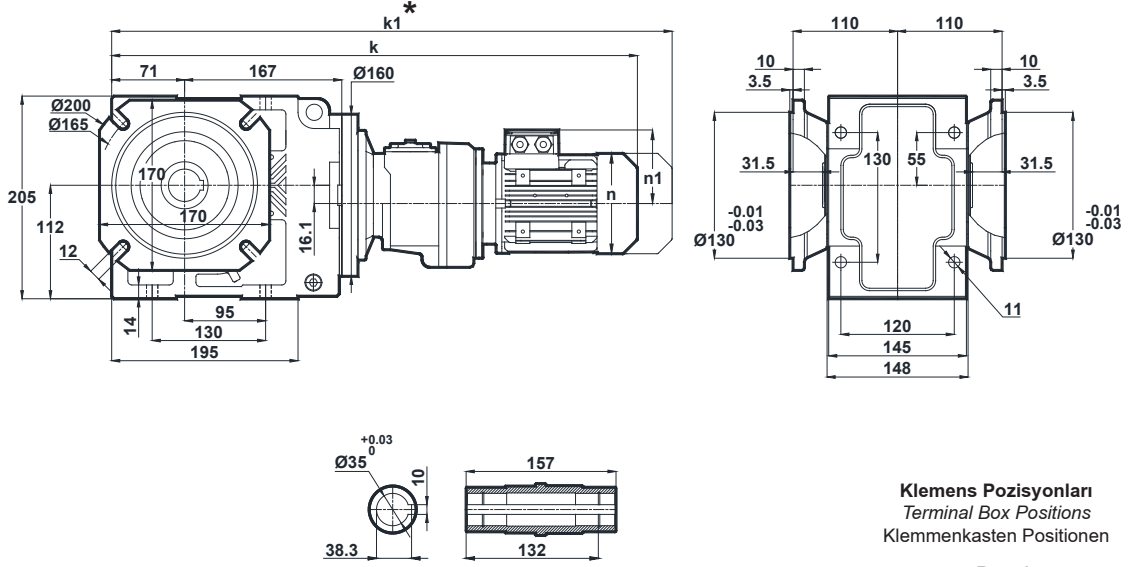

**Klemens Pozisyonları**  
Terminal Box Positions  
Klemmenkasten Positionen

	63	71	80
k	581	610	644
k1	642	701	737
n	121	137	155
n1	97	112	121

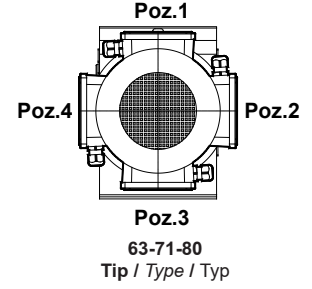

\* "k1" Ölçüsü frenli redüktörlere aittir.  
Dimension "k1" is for motors with brake.  
Maße "k1" ist für Bremsenmotoren.

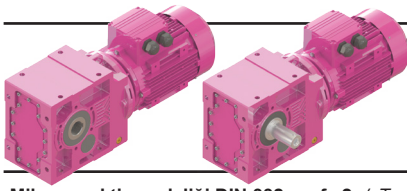

# Ölçü Sayfaları

## Dimension Pages

### Abmessungsseiten

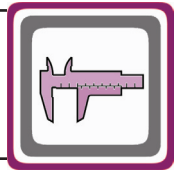

-Mil ucu çektirme deliği DIN 332 sayfa 2 / Tapped center hole to DIN 332, sheet 2 / Zentrierung mit Gewinde DIN 332, Blatt 2

#### KR373.00

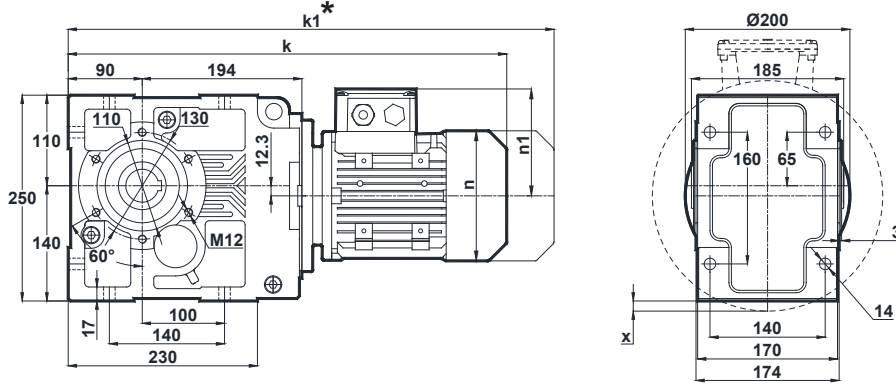

**Std.**

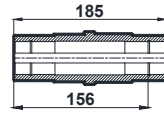
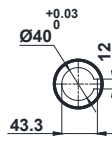

**Ops.**

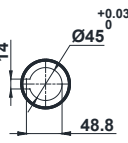

x: Motor Ayak bağlantı yüzeyinin altında ise  
x: If Motor is lower than foot mounting plane  
x: Wenn der Motor unter der Fußmontageebene ist

**Klemens Pozisyonları**  
Terminal Box Positions  
Klemmenkasten Positionen

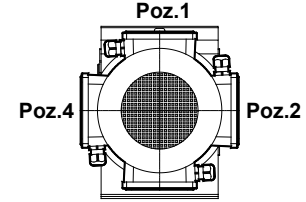

**Poz.3**  
71-80-90-100-112-132  
Tip / Type / Typ

	71	80	90S	90L	100L	112M	132S	132M
k	496	530	569	569	617	641	728	728
k1	587	623	673.5	673.5	736.5	745.5	858	858
n	137	155	176	176	193	215	257	257
n1	112	121	132	132	147	158	179	179
x	-	-	-	-	-	-	0.8	0.8

#### KR373.01

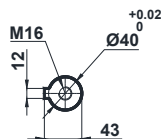
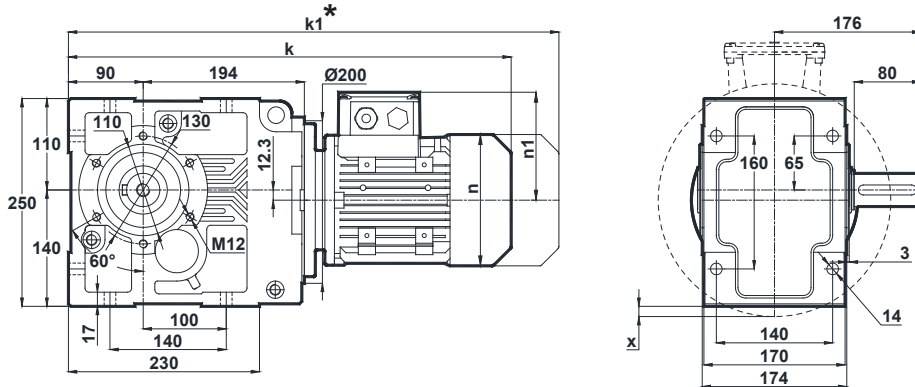

x: Motor Ayak bağlantı yüzeyinin altında ise  
x: If Motor is lower than foot mounting plane  
x: Wenn der Motor unter der Fußmontageebene ist

	71	80	90S	90L	100L	112M	132S	132M
k	496	530	569	569	617	641	728	728
k1	587	623	673.5	673.5	736.5	745.5	858	858
n	137	155	176	176	193	215	257	257
n1	112	121	132	132	147	158	179	179
x	-	-	-	-	-	-	0.8	0.8

\* "k1" Ölçüsü frenli redüktörlere aittir.  
Dimension "k1" is for motors with brake.  
Maße "k1" ist für Bremsenmotoren.

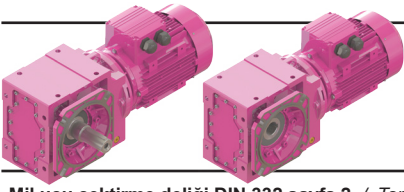

# Ölçü Sayfaları

## Dimension Pages

### Abmessungsseiten

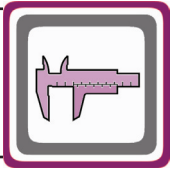

-Mil ucu çektirme deliği DIN 332 sayfa 2 / Tapped center hole to DIN 332, sheet 2 / Zentrierung mit Gewinde DIN 332, Blatt 2

#### KR373.02

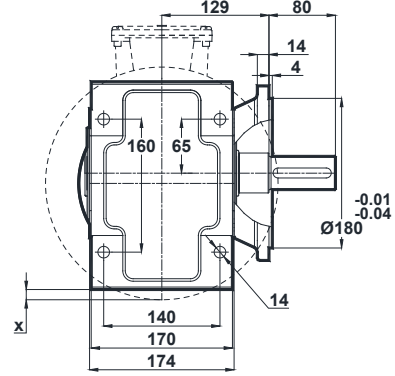
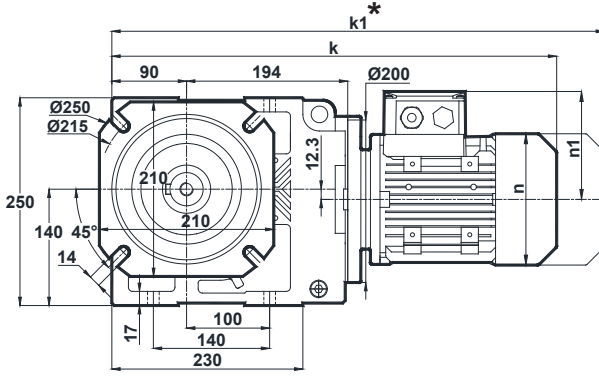

x: Motor Ayak bağlantı yüzeyinin altında ise  
 x: If Motor is lower than foot mounting plane  
 x: Wenn der Motor unter der Fußmontageebene ist

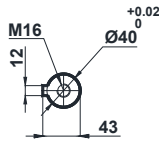

	71	80	90S	90L	100L	112M	132S	132M
k	496	530	569	569	617	641	728	728
k1	587	623	673.5	673.5	736.5	745.5	858	858
n	137	155	176	176	193	215	257	257
n1	112	121	132	132	147	158	179	179
x	-	-	-	-	-	-	0.8	0.8

Klemens Pozisyonları  
 Terminal Box Positions  
 Klemmenkasten Positionen

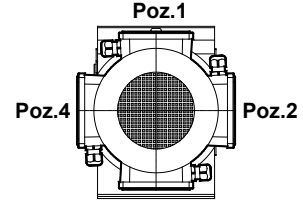

Poz.3  
 71-80-90-100-112-132  
 Tip / Type / Typ

#### KR373.03

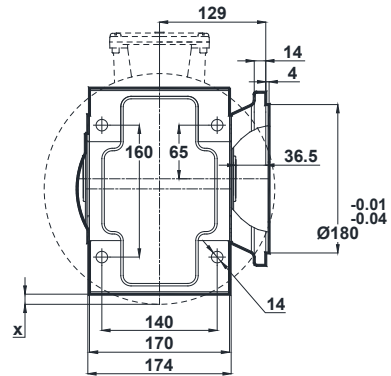
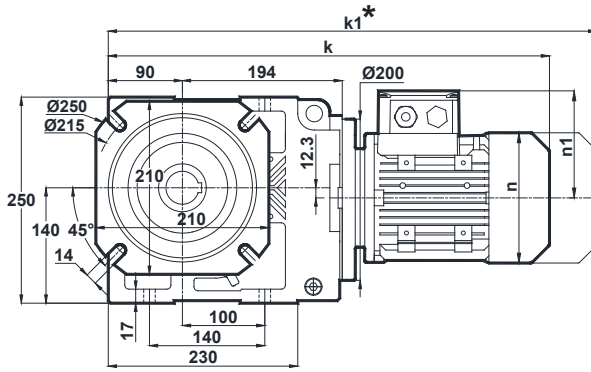

Std.

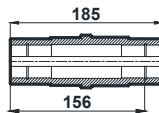

Ops.

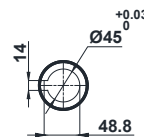

x: Motor Ayak bağlantı yüzeyinin altında ise  
 x: If Motor is lower than foot mounting plane  
 x: Wenn der Motor unter der Fußmontageebene ist

	71	80	90S	90L	100L	112M	132S	132M
k	496	530	569	569	617	641	728	728
k1	587	623	673.5	673.5	736.5	745.5	858	858
n	137	155	176	176	193	215	257	257
n1	112	121	132	132	147	158	179	179
x	-	-	-	-	-	-	0.8	0.8

\* "k1" Ölçüsü frenli redüktörlere aittir.  
 Dimension "k1" is for motors with brake.  
 Maße "k1" ist für Bremsenmotoren.

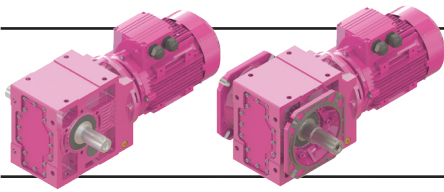

# Ölçü Sayfaları

## Dimension Pages

### Abmessungsseiten

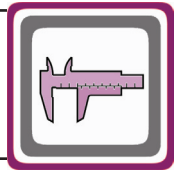

-Mil ucu çekirme deliği DIN 332 sayfa 2 / Tapped center hole to DIN 332, sheet 2 / Zentrierung mit Gewinde DIN 332, Blatt 2

#### KR373.04

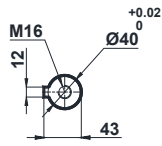
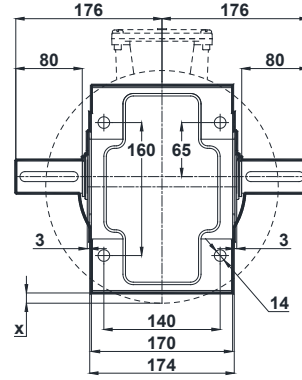
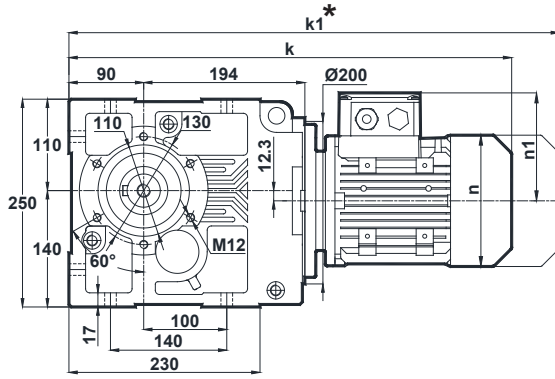

x: Motor Ayak bağlantı yüzeyinin altında ise  
x: If Motor is lower than foot mounting plane  
x: Wenn der Motor unter der Fußmontageebene ist

**Klemens Pozisyonları**  
Terminal Box Positions  
Klemmenkasten Positionen

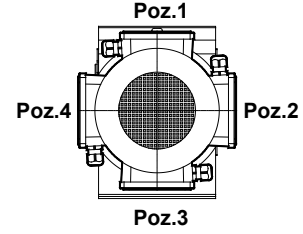

71-80-90-100-112-132  
Tip / Type / Typ

	71	80	90S	90L	100L	112M	132S	132M
k	496	530	569	569	617	641	728	728
k1	587	623	673.5	673.5	736.5	745.5	858	858
n	137	155	176	176	193	215	257	257
n1	112	121	132	132	147	158	179	179
x	-	-	-	-	-	-	0.8	0.8

#### KR373.05

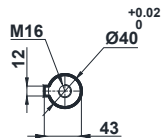
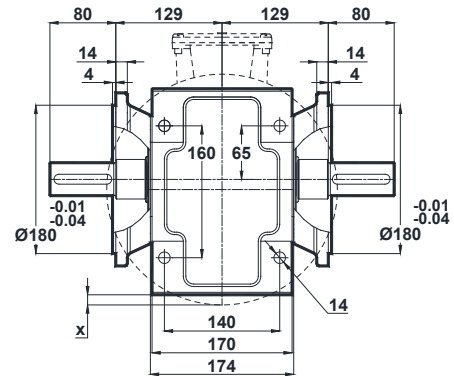
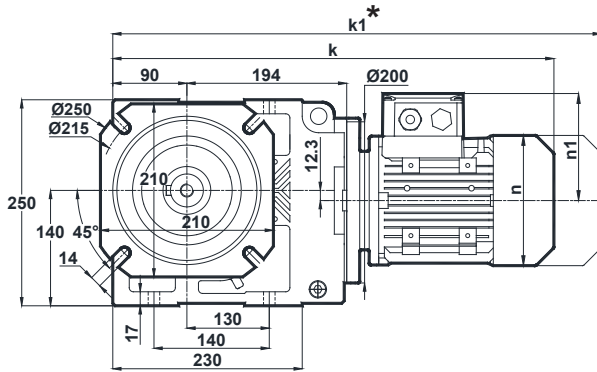

x: Motor Ayak bağlantı yüzeyinin altında ise  
x: If Motor is lower than foot mounting plane  
x: Wenn der Motor unter der Fußmontageebene ist

	71	80	90S	90L	100L	112M	132S	132M
k	496	530	569	569	617	641	728	728
k1	587	623	673.5	673.5	736.5	745.5	858	858
n	137	155	176	176	193	215	257	257
n1	112	121	132	132	147	158	179	179
x	-	-	-	-	-	-	0.8	0.8

\* "k1" Ölçüsü frenli redüktörlere aittir.  
Dimension "k1" is for motors with brake.  
Maße "k1" ist für Bremsenmotoren.

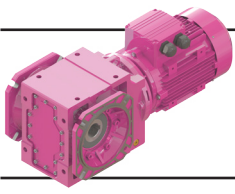

# Ölçü Sayfaları

## Dimension Pages

### Abmessungsseiten

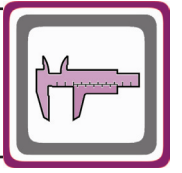

-Mil ucu çekirme deliği DIN 332 sayfa 2 / Tapped center hole to DIN 332, sheet 2 / Zentrierung mit Gewinde DIN 332, Blatt 2

KR373.08

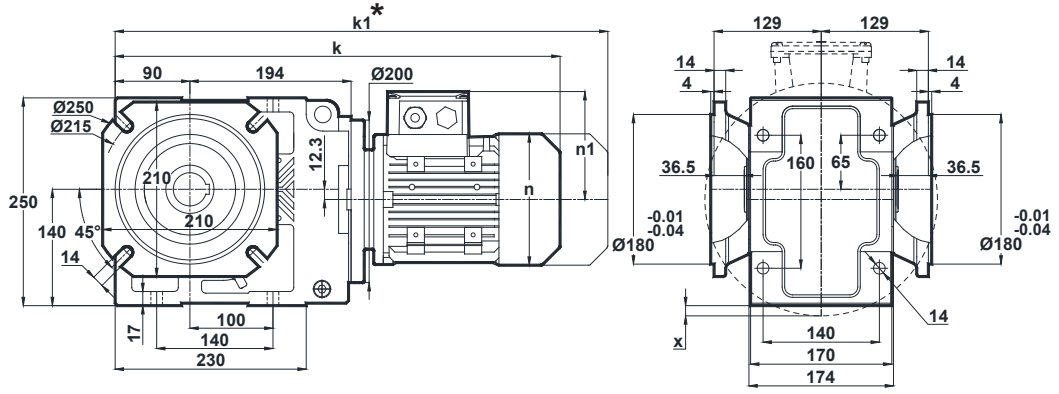

Std.

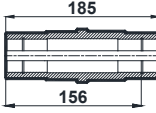

Ops.

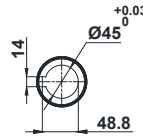

x: Motor Ayak bağlantı yüzeyinin altında ise  
x: If Motor is lower than foot mounting plane  
x: Wenn der Motor unter der Fußmontageebene ist

**Klemens Pozisyonları**  
Terminal Box Positions  
Klemmenkasten Positionen

Poz.1

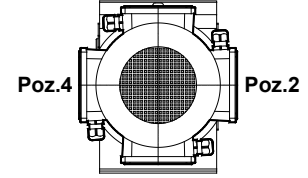

Poz.3

71-80-90-100-112-132  
Tip / Type / Typ

	71	80	90S	90L	100L	112M	132S	132M
k	496	530	569	569	617	641	728	728
k1	587	623	673.5	673.5	736.5	745.5	858	858
n	137	155	176	176	193	215	257	257
n1	112	121	132	132	147	158	179	179
x	-	-	-	-	-	-	0.8	0.8

\* "k1" Ölçüsü frenli redüktörlere aittir.  
Dimension "k1" is for motors with brake.  
Maße "k1" ist für Bremsenmotoren.

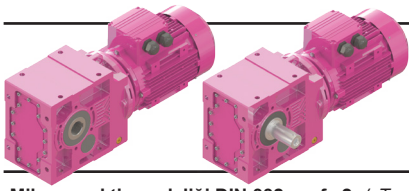

# Ölçü Sayfaları

## Dimension Pages

### Abmessungsseiten

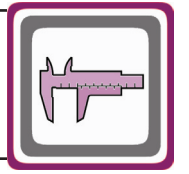

-Mil ucu çektirme deliği DIN 332 sayfa 2 / Tapped center hole to DIN 332, sheet 2 / Zentrierung mit Gewinde DIN 332, Blatt 2

#### KR374.00

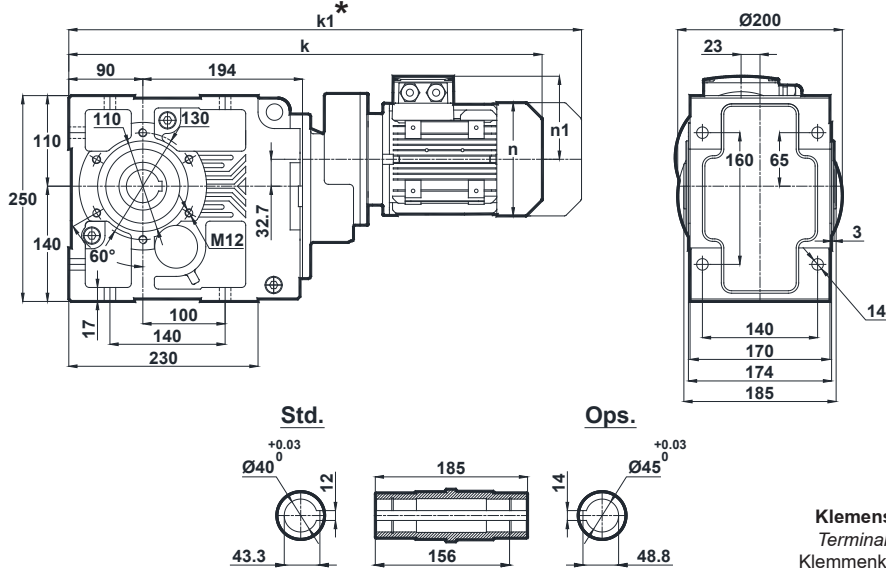

	63	71	80
<b>k</b>	547	566	595
<b>k1</b>	608	657	688
<b>n</b>	121	137	155
<b>n1</b>	97	112	121

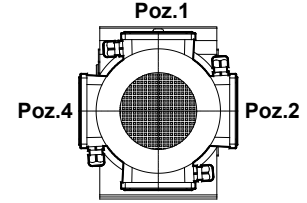

63-71-80  
Tip / Type / Typ

#### KR374.01

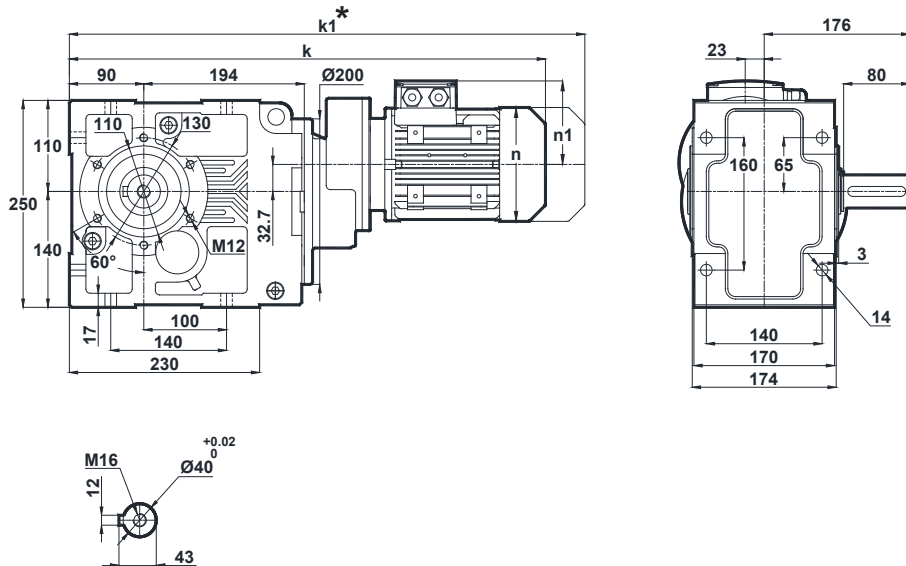

	63	71	80
<b>k</b>	547	566	595
<b>k1</b>	608	657	688
<b>n</b>	121	137	155
<b>n1</b>	97	112	121

\* "k1" Ölçüsü frenli redüktörlere aittir.  
Dimension "k1" is for motors with brake.  
Maße "k1" ist für Bremsenmotoren.

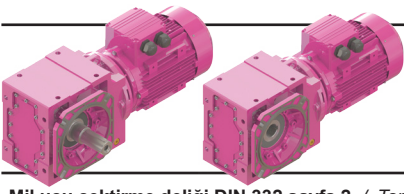

# Ölçü Sayfaları

## Dimension Pages

### Abmessungsseiten

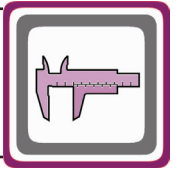

-Mil ucu çektirme deliği DIN 332 sayfa 2 / Tapped center hole to DIN 332, sheet 2 / Zentrierung mit Gewinde DIN 332, Blatt 2

#### KR374.02

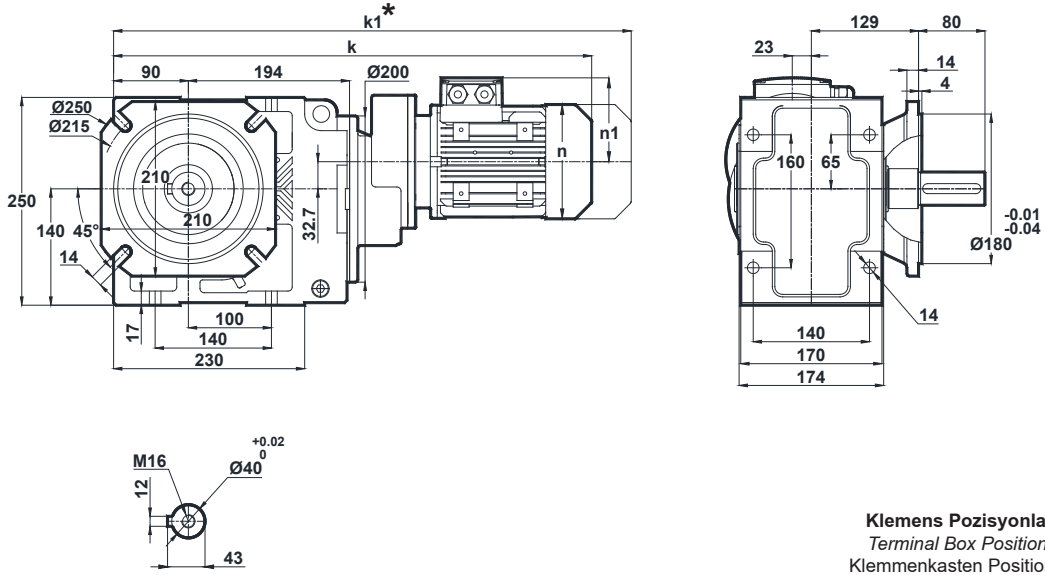

	63	71	80
k	547	566	595
k1	608	657	688
n	121	137	155
n1	97	112	121

**Klemens Pozisyonları**  
Terminal Box Positions  
Klemmenkasten Positionen

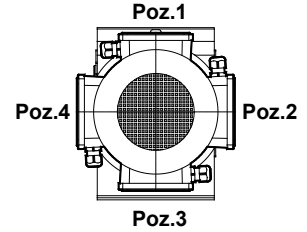

**63-71-80**  
Tip / Type / Typ

#### KR374.03

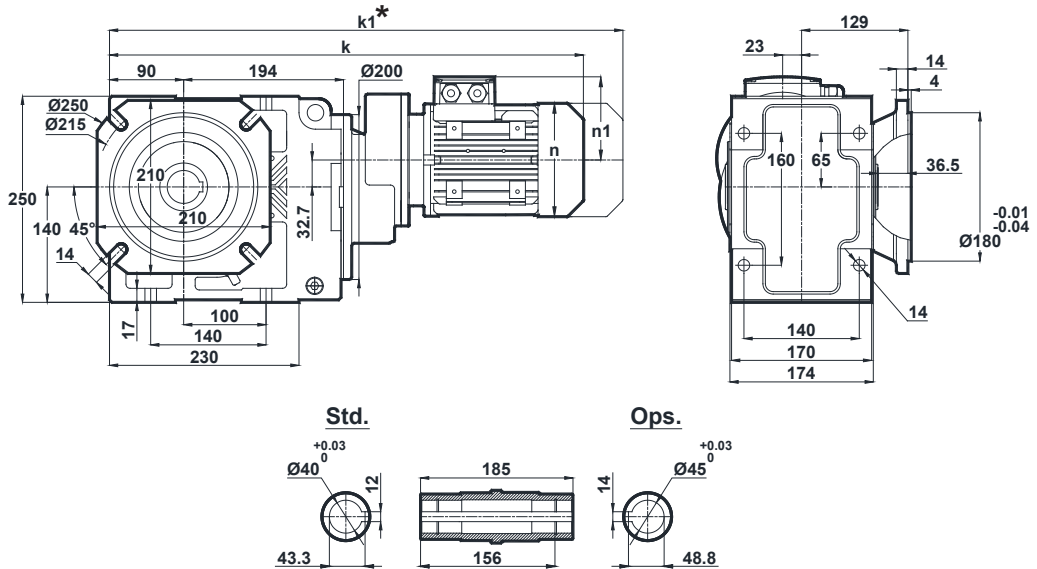

	63	71	80
k	547	566	595
k1	608	657	688
n	121	137	155
n1	97	112	121

\* "k1" Ölçüsü frenli redüktörlere aittir.  
Dimension "k1" is for motors with brake.  
Maße "k1" ist für Bremsenmotoren.

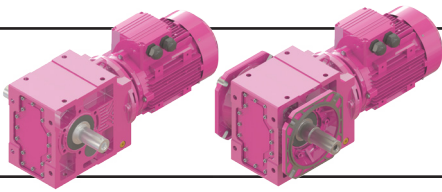

# Ölçü Sayfaları

## Dimension Pages

### Abmessungsseiten

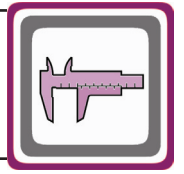

-Mil ucu çektirme deliği DIN 332 sayfa 2 / Tapped center hole to DIN 332, sheet 2 / Zentrierung mit Gewinde DIN 332, Blatt 2

#### KR374.04

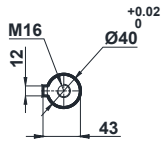
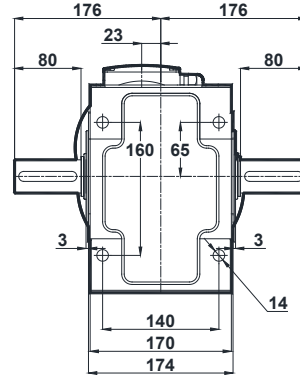
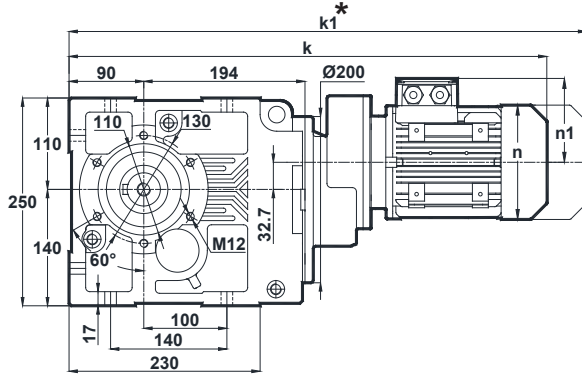

	63	71	80
k	547	566	595
k1	608	657	688
n	121	137	155
n1	97	112	121

**Klemens Pozisyonları**  
Terminal Box Positions  
Klemmenkasten Positionen

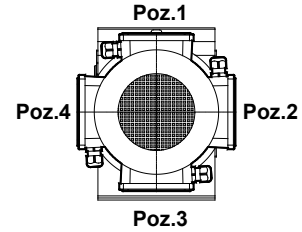

**63-71-80**  
Tip / Type / Typ

#### KR374.05

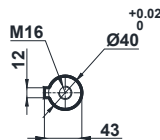
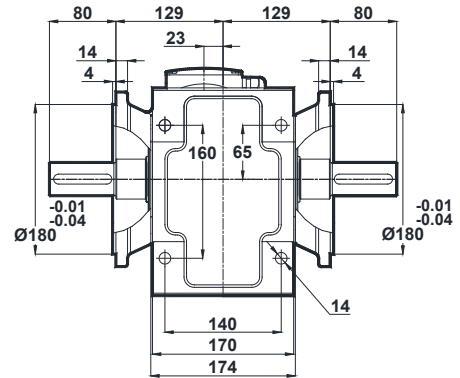
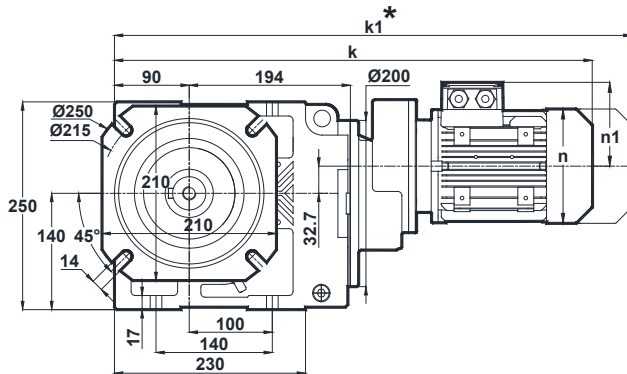

	63	71	80
k	547	566	595
k1	608	657	688
n	121	137	155
n1	97	112	121

\* "k1" Ölçüsü frenli redüktörlere aittir.  
Dimension "k1" is for motors with brake.  
Maße "k1" ist für Bremsenmotoren.



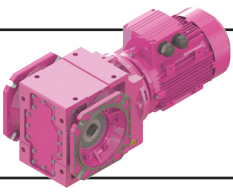

# Ölçü Sayfaları Dimension Pages Abmessungsseiten

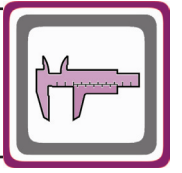

-Mil ucu çektirme deliği DIN 332 sayfa 2 / Tapped center hole to DIN 332, sheet 2 / Zentrierung mit Gewinde DIN 332, Blatt 2

KR374.08

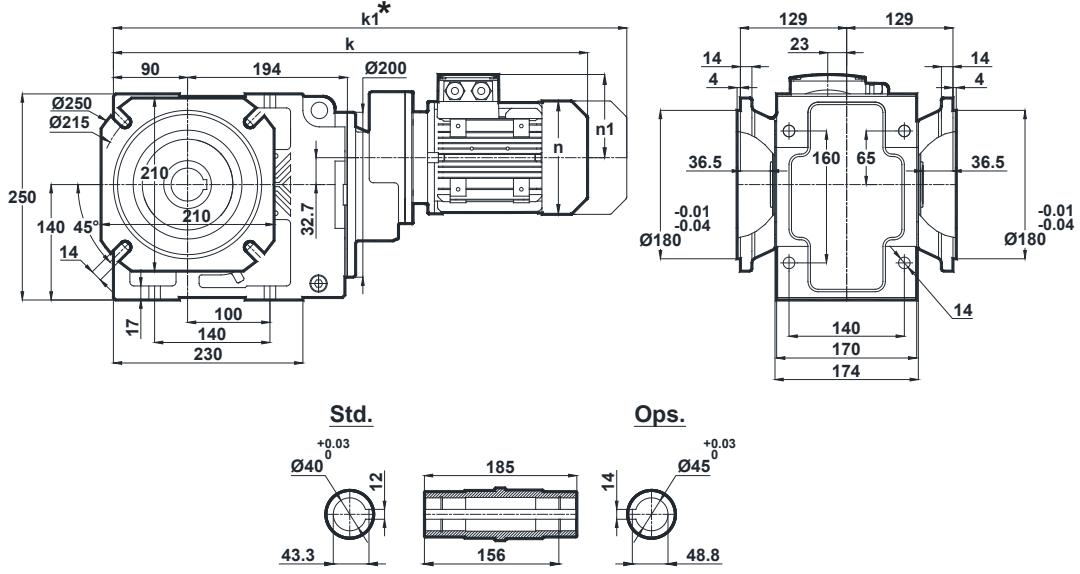

	63	71	80
k	547	566	595
k1	608	657	688
n	121	137	155
n1	97	112	121

**Klemens Pozisyonları**  
Terminal Box Positions  
Klemmenkasten Positionen

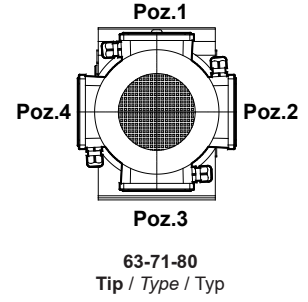

\* "k1" Ölçüsü frenli redüktörlere aittir.  
Dimension "k1" is for motors with brake.  
Maße "k1" ist für Bremsenmotoren.

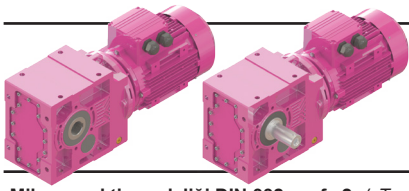

# Ölçü Sayfaları

## Dimension Pages

### Abmessungsseiten

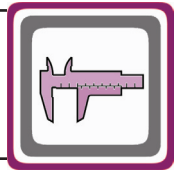

-Mil ucu çektirme deliği DIN 332 sayfa 2 / Tapped center hole to DIN 332, sheet 2 / Zentrierung mit Gewinde DIN 332, Blatt 2

KR375.00  
KR376.00

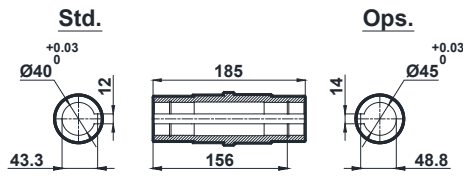
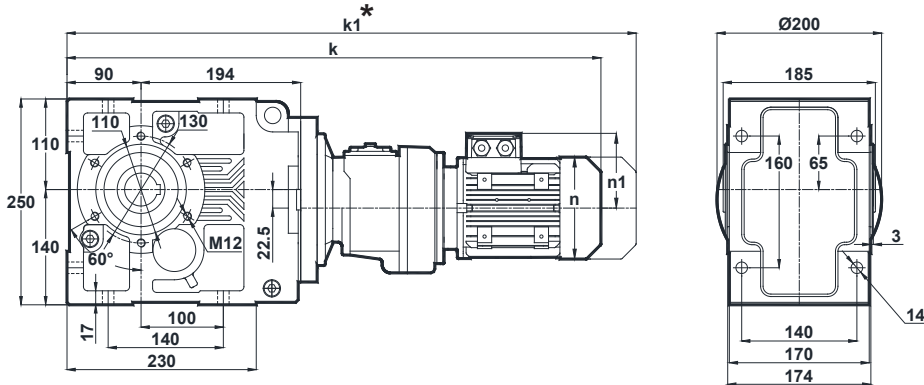

Klemens Pozisyonları  
Terminal Box Positions  
Klemmenkasten Positionen

	63	71
k	647	676
k1	708	767
n	121	137
n1	97	112

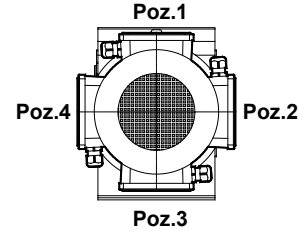

63-71  
Tip / Type / Typ

KR375.01  
KR376.01

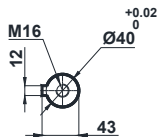
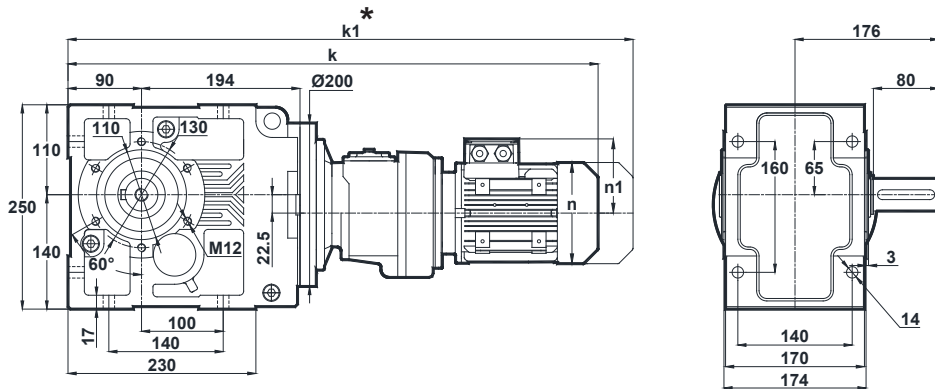

	63	71
k	647	676
k1	708	767
n	121	137
n1	97	112

\* "k1" Ölçüsü frenli redüktörlere aittir.  
Dimension "k1" is for motors with brake.  
Maße "k1" ist für Bremsenmotoren.

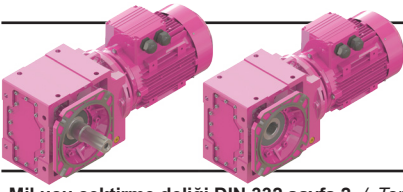

# Ölçü Sayfaları

## Dimension Pages

### Abmessungsseiten

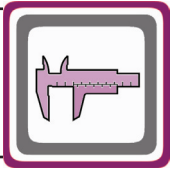

-Mil ucu çektirme deliği DIN 332 sayfa 2 / Tapped center hole to DIN 332, sheet 2 / Zentrierung mit Gewinde DIN 332, Blatt 2

KR375.02  
KR376.02

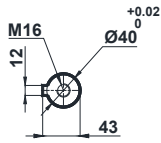
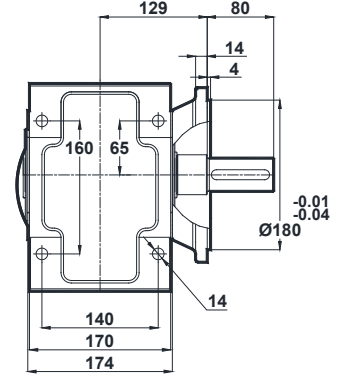
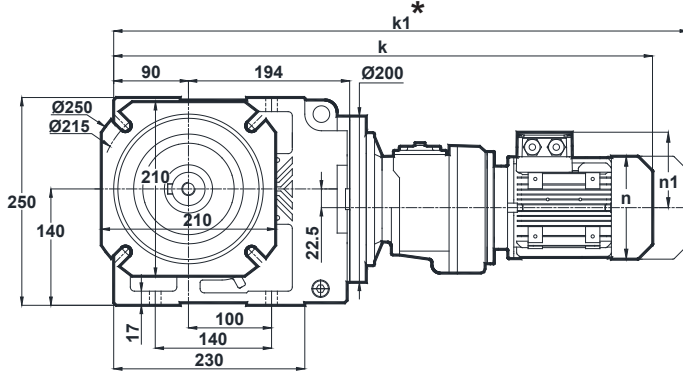

	63	71
k	647	676
k1	708	767
n	121	137
n1	97	112

Klemens Pozisyonları  
Terminal Box Positions  
Klemmenkasten Positionen

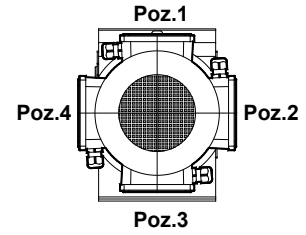

63-71  
Tip / Type / Typ

KR375.03  
KR376.03

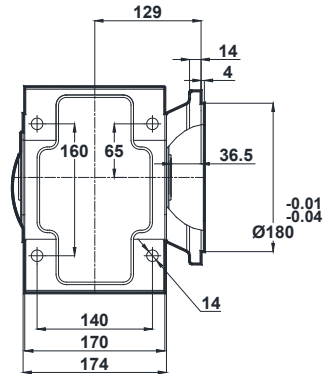
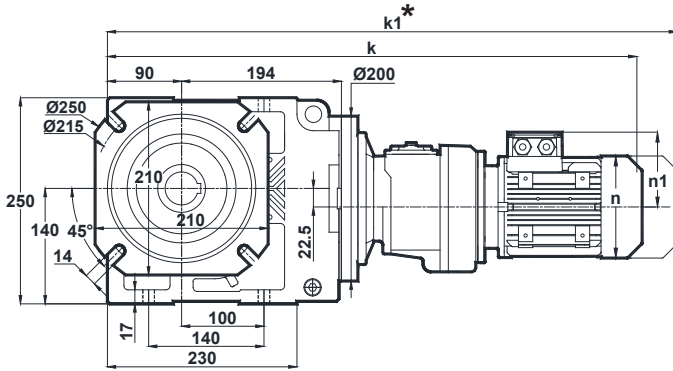

Std.

Ops.

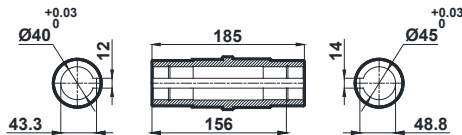

	63	71
k	647	676
k1	708	767
n	121	137
n1	97	112

\* "k1" Ölçüsü frenli redüktörlere aittir.  
Dimension "k1" is for motors with brake.  
Maße "k1" ist für Bremsenmotoren.

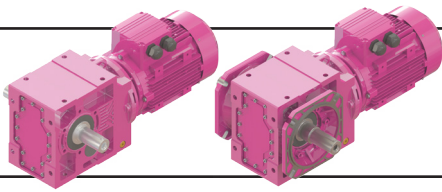

# Ölçü Sayfaları

## Dimension Pages

### Abmessungsseiten

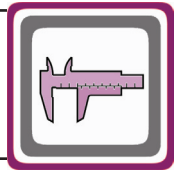

-Mil ucu çektirme deliği DIN 332 sayfa 2 / Tapped center hole to DIN 332, sheet 2 / Zentrierung mit Gewinde DIN 332, Blatt 2

KR375.04  
KR376.04

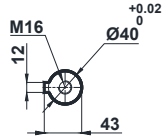
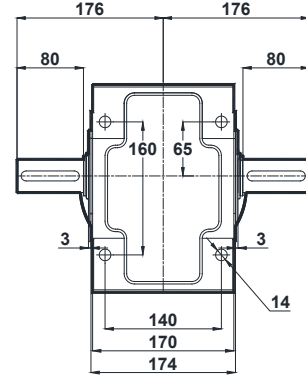
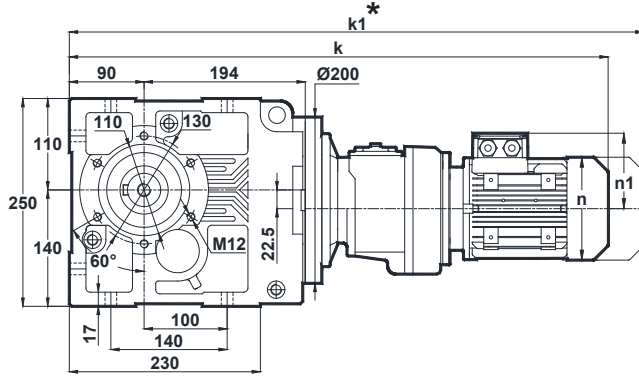

	63	71
k	647	676
k1	708	767
n	121	137
n1	97	112

Klemens Pozisyonları  
Terminal Box Positions  
Klemmenkasten Positionen

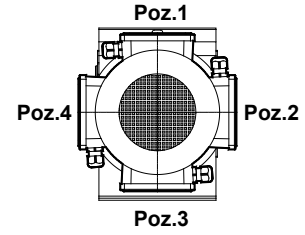

63-71  
Tip / Type / Typ

KR375.05  
KR376.05

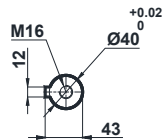
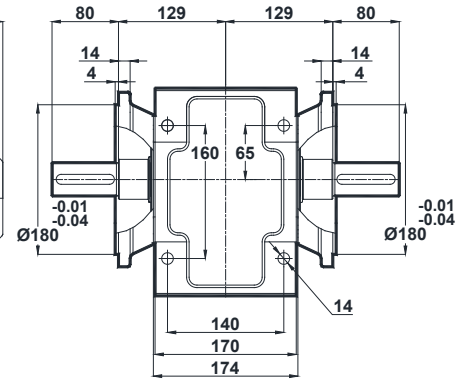
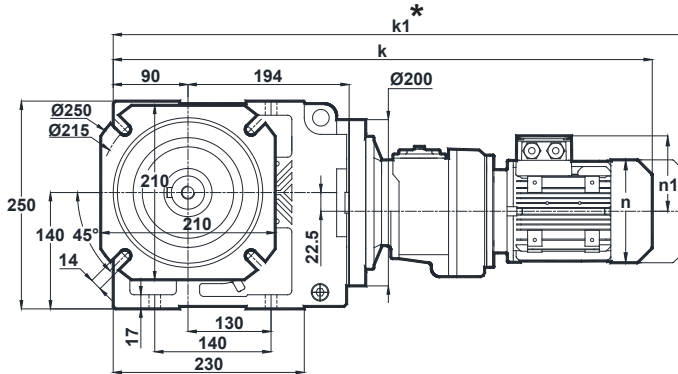

	63	71
k	647	676
k1	708	767
n	121	137
n1	97	112

\* " k1 " Ölçüsü frenli redüktörlere aittir.  
Dimension " k1 " is for motors with brake.  
Maße " k1 " ist für Bremsenmotoren.

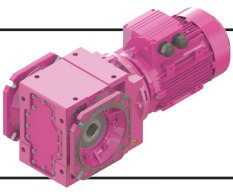

# Ölçü Sayfaları Dimension Pages Abmessungsseiten

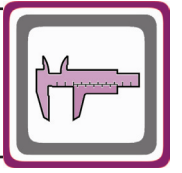

-Mil ucu çektirme deliği DIN 332 sayfa 2 / Tapped center hole to DIN 332, sheet 2 / Zentrierung mit Gewinde DIN 332, Blatt 2

KR375.08  
KR376.08

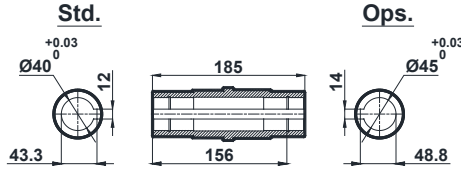
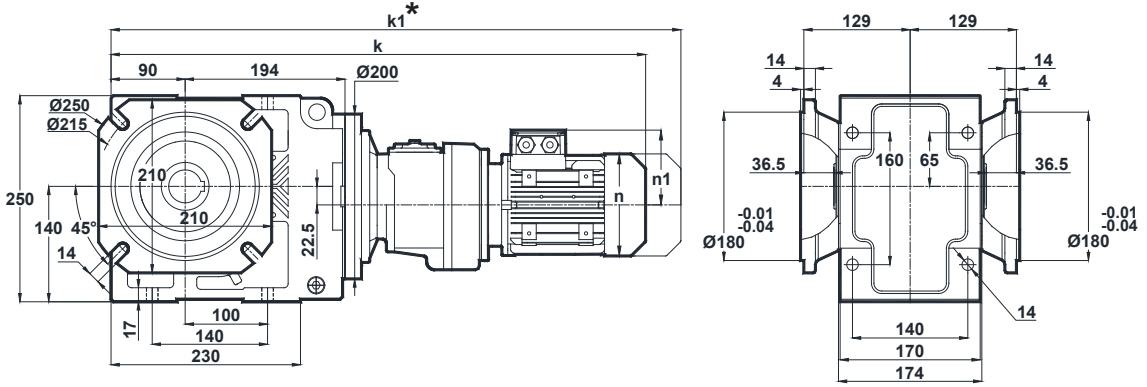

Klemens Pozisyonları  
Terminal Box Positions  
Klemmenkasten Positionen

	63	71
k	647	676
k1	708	767
n	121	137
n1	97	112

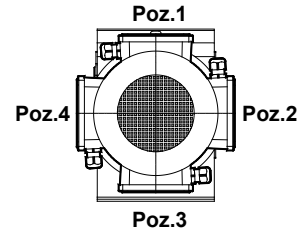

63-71  
Tip / Type / Typ

\* "k1" Ölçüsü frenli redüktörlere aittir.  
Dimension "k1" is for motors with brake.  
Maße "k1" ist für Bremsenmotoren.

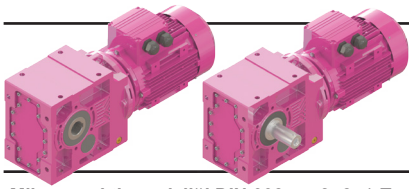

# Ölçü Sayfaları

## Dimension Pages

### Abmessungsseiten

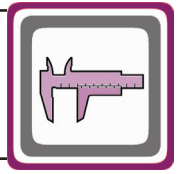

-Mil ucu çekirme deliği DIN 332 sayfa 2 / Tapped center hole to DIN 332, sheet 2 / Zentrierung mit Gewinde DIN 332, Blatt 2

#### KR473.00

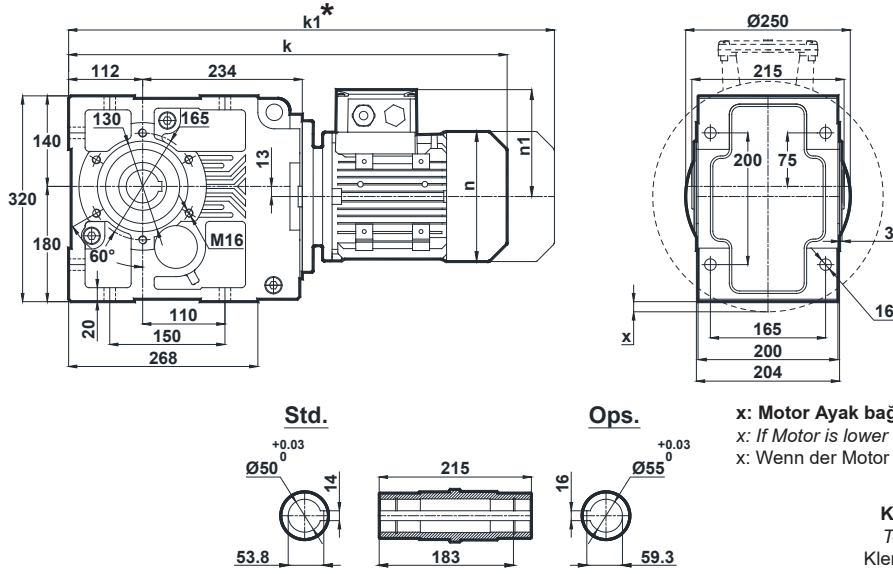

x: Motor Ayak bağlantı yüzeyinin altında ise  
x: If Motor is lower than foot mounting plane  
x: Wenn der Motor unter der Fußmontageebene ist

**Klemens Pozisyonları**  
Terminal Box Positions  
Klemmenkasten Positionen

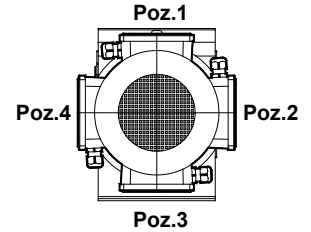

80-90-100-112-132-160-180  
Tip / Type / Typ

	80	90S	90L	100L	112M	132S	132M	160M	160L	180M	180L
k	587	626	626	670	695	780	780	876	876	947	947
k1	680	730.5	730.5	789.5	799.5	910	910	1056	1056	1117.5	1117.5
n	155	176	176	193	215	257	257	315	315	347	347
n1	121	132	132	147	158	179	179	219	219	234	234
x	-	-	-	-	-	-	-	-	-	6.5	6.5

#### KR473.01

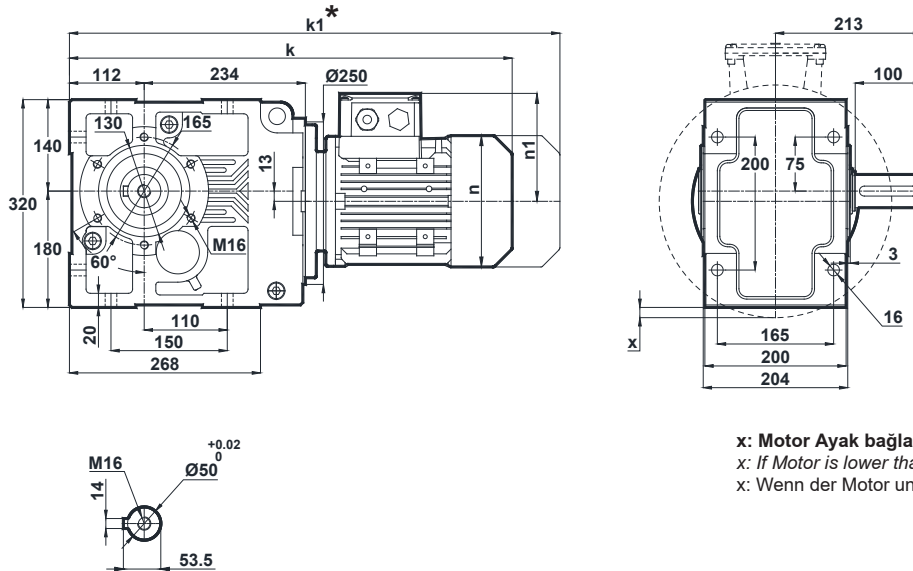

x: Motor Ayak bağlantı yüzeyinin altında ise  
x: If Motor is lower than foot mounting plane  
x: Wenn der Motor unter der Fußmontageebene ist

	80	90S	90L	100L	112M	132S	132M	160M	160L	180M	180L
k	587	626	626	670	695	780	780	876	876	947	947
k1	680	730.5	730.5	789.5	799.5	910	910	1056	1056	1117.5	1117.5
n	155	176	176	193	215	257	257	315	315	347	347
n1	121	132	132	147	158	179	179	219	219	234	234
x	-	-	-	-	-	-	-	-	-	6.5	6.5

\* "k1" Ölçüsü frenli redüktörlere aittir.  
Dimension "k1" is for motors with brake.  
Maße "k1" ist für Bremsenmotoren.

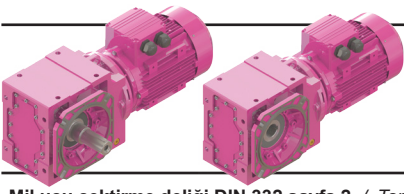

# Ölçü Sayfaları Dimension Pages Abmessungsseiten

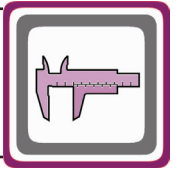

-Mil ucu çektirme deliği DIN 332 sayfa 2 / Tapped center hole to DIN 332, sheet 2 / Zentrierung mit Gewinde DIN 332, Blatt 2

## KR473.02

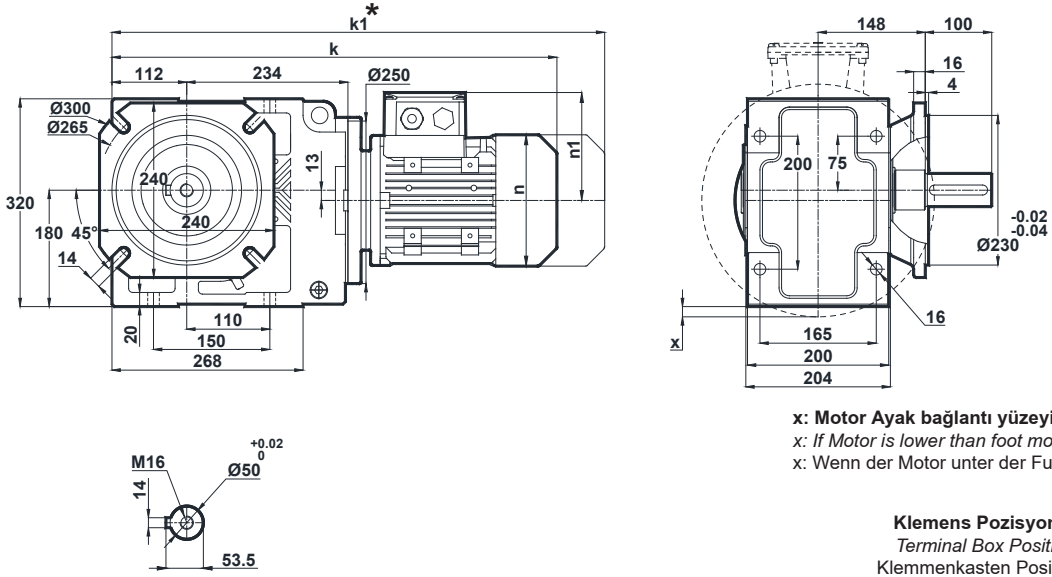

x: Motor Ayak bağlantı yüzeyinin altında ise  
x: If Motor is lower than foot mounting plane  
x: Wenn der Motor unter der Fußmontageebene ist

Klemens Pozisyonları  
Terminal Box Positions  
Klemmenkasten Positionen

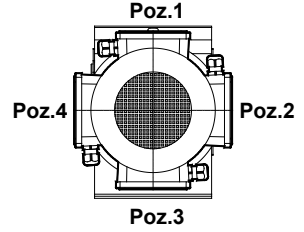

80-90-100-112-132-160-180  
Tip / Type / Typ

	80	90S	90L	100L	112M	132S	132M	160M	160L	180M	180L
k	587	626	626	670	695	780	780	876	876	947	947
k1	680	730.5	730.5	789.5	799.5	910	910	1056	1056	1117.5	1117.5
n	155	176	176	193	215	257	257	315	315	347	347
n1	121	132	132	147	158	179	179	219	219	234	234
x	-	-	-	-	-	-	-	-	-	6.5	6.5

## KR473.03

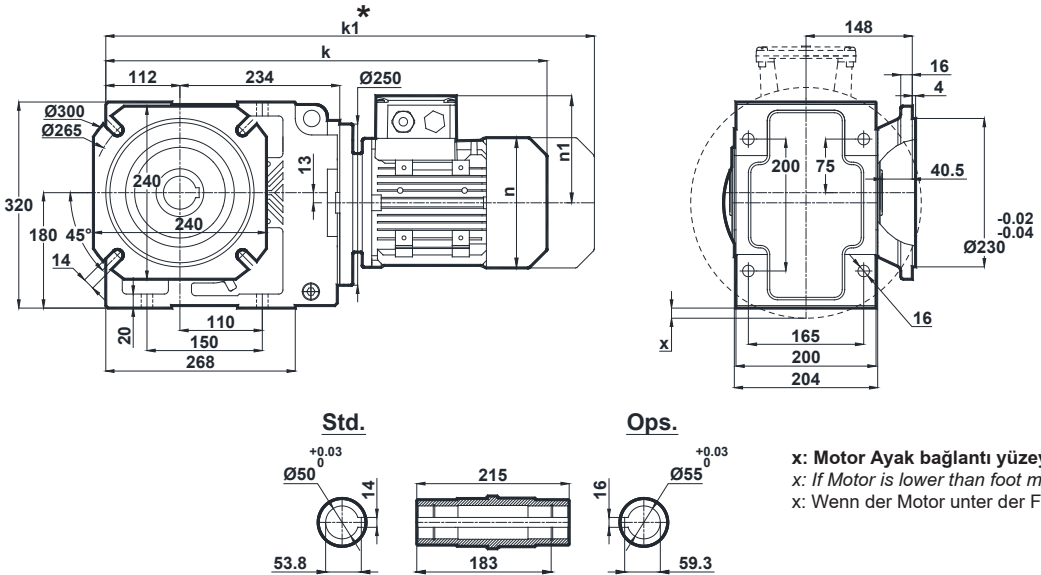

x: Motor Ayak bağlantı yüzeyinin altında ise  
x: If Motor is lower than foot mounting plane  
x: Wenn der Motor unter der Fußmontageebene ist

	80	90S	90L	100L	112M	132S	132M	160M	160L	180M	180L
k	587	626	626	670	695	780	780	876	876	947	947
k1	680	730.5	730.5	789.5	799.5	910	910	1056	1056	1117.5	1117.5
n	155	176	176	193	215	257	257	315	315	347	347
n1	121	132	132	147	158	179	179	219	219	234	234
x	-	-	-	-	-	-	-	-	-	6.5	6.5

\* "k1" Ölçüsü frenli redüktörlere aittir.  
Dimension "k1" is for motors with brake.  
Maße "k1" ist für Bremsenmotoren.

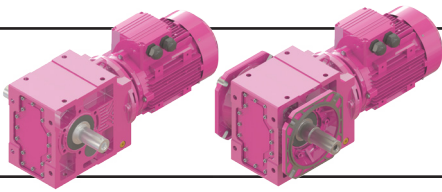

# Ölçü Sayfaları

## Dimension Pages

### Abmessungsseiten

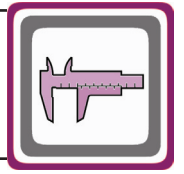

-Mil ucu çektirme deliği DIN 332 sayfa 2 / Tapped center hole to DIN 332, sheet 2 / Zentrierung mit Gewinde DIN 332, Blatt 2

#### KR473.04

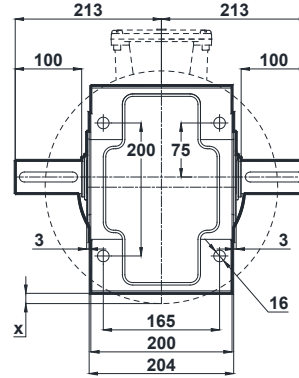
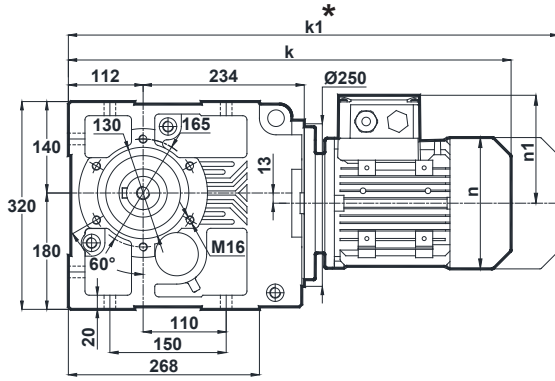

x: Motor Ayak bağlantı yüzeyinin altında ise  
x: If Motor is lower than foot mounting plane  
x: Wenn der Motor unter der Fußmontageebene ist

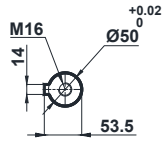

Klemens Pozisyonları  
Terminal Box Positions  
Klemmenkasten Positionen

	80	90S	90L	100L	112M	132S	132M	160M	160L	180M	180L
k	587	626	626	670	695	780	780	876	876	947	947
k1	680	730.5	730.5	789.5	799.5	910	910	1056	1056	1117.5	1117.5
n	155	176	176	193	215	257	257	315	315	347	347
n1	121	132	132	147	158	179	179	219	219	234	234
x	-	-	-	-	-	-	-	-	-	6.5	6.5

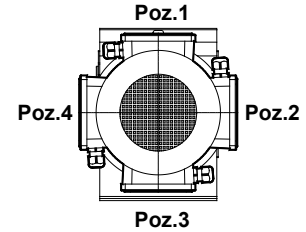

80-90-100-112-132-160-180  
Tip / Type / Typ

#### KR473.05

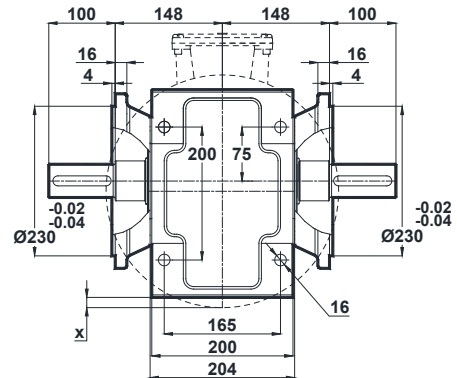
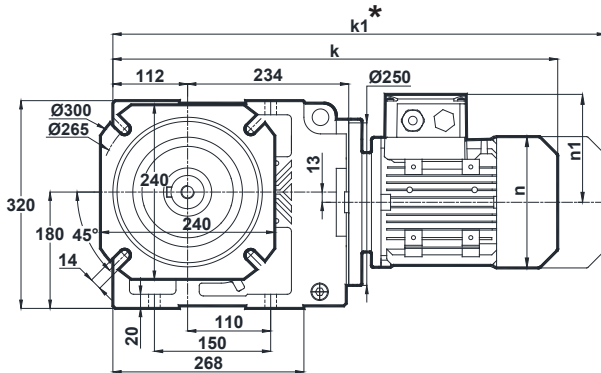

x: Motor Ayak bağlantı yüzeyinin altında ise  
x: If Motor is lower than foot mounting plane  
x: Wenn der Motor unter der Fußmontageebene ist

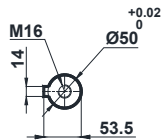

	80	90S	90L	100L	112M	132S	132M	160M	160L	180M	180L
k	587	626	626	670	695	780	780	876	876	947	947
k1	680	730.5	730.5	789.5	799.5	910	910	1056	1056	1117.5	1117.5
n	155	176	176	193	215	257	257	315	315	347	347
n1	121	132	132	147	158	179	179	219	219	234	234
x	-	-	-	-	-	-	-	-	-	6.5	6.5

\* "k1" Ölçüsü frenli redüktörlere aittir.  
Dimension "k1" is for motors with brake.  
Maße "k1" ist für Bremsenmotoren.



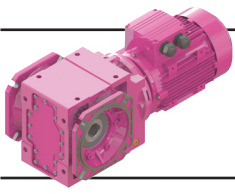

# Ölçü Sayfaları Dimension Pages Abmessungsseiten

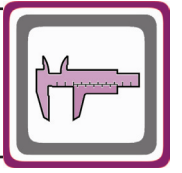

-Mil ucu çektirme deliği DIN 332 sayfa 2 / Tapped center hole to DIN 332, sheet 2 / Zentrierung mit Gewinde DIN 332, Blatt 2

KR473.08

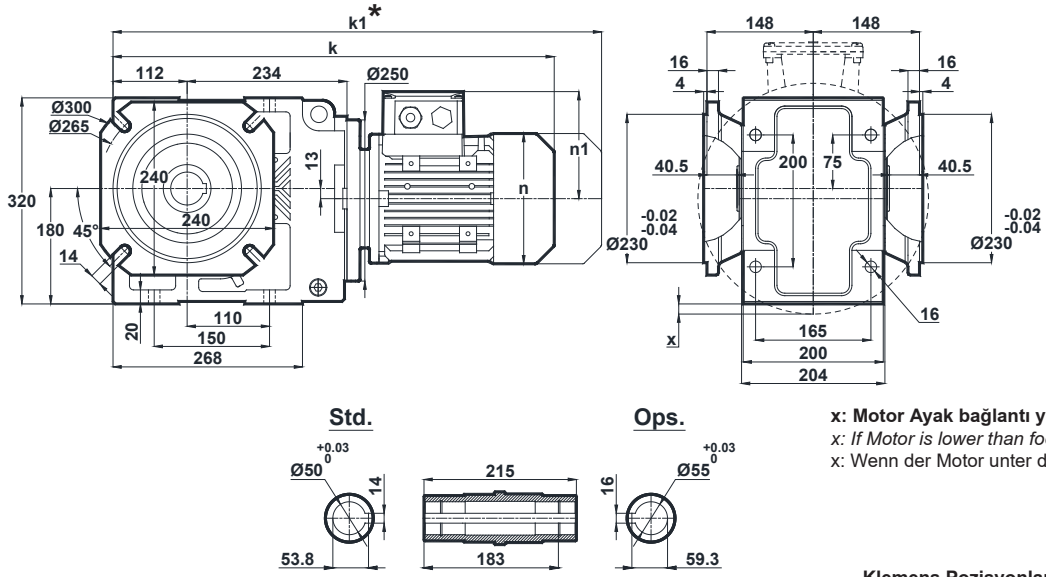

	80	90S	90L	100L	112M	132S	132M	160M	160L	180M	180L
k	587	626	626	670	695	780	780	876	876	947	947
k1	680	730.5	730.5	789.5	799.5	910	910	1056	1056	1117.5	1117.5
n	155	176	176	193	215	257	257	315	315	347	347
n1	121	132	132	147	158	179	179	219	219	234	234
x	-	-	-	-	-	-	-	-	-	6.5	6.5

**Klemens Pozisyonları**  
Terminal Box Positions  
Klemmenkasten Positionen

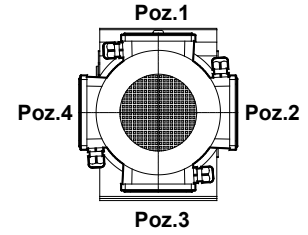

80-90-100-112-132-160-180  
Tip / Type / Typ

\* "k1" Ölçüsü frenli redüktörlere aittir.  
Dimension "k1" is for motors with brake.  
Maße "k1" ist für Bremsenmotoren.

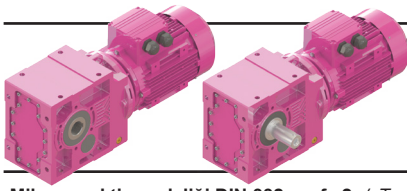

# Ölçü Sayfaları

## Dimension Pages

### Abmessungsseiten

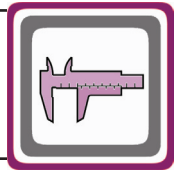

-Mil ucu çekirme deliği DIN 332 sayfa 2 / Tapped center hole to DIN 332, sheet 2 / Zentrierung mit Gewinde DIN 332, Blatt 2

#### KR474.00

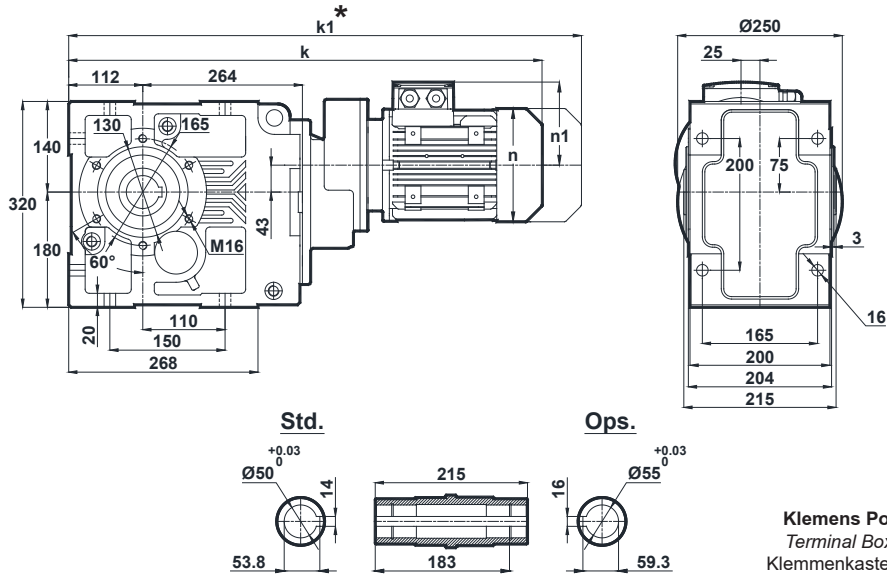

	71	80
k	646	680
k1	737	773
n	137	155
n1	112	121

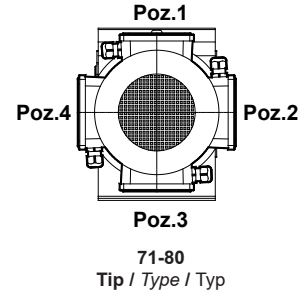

#### KR474.01

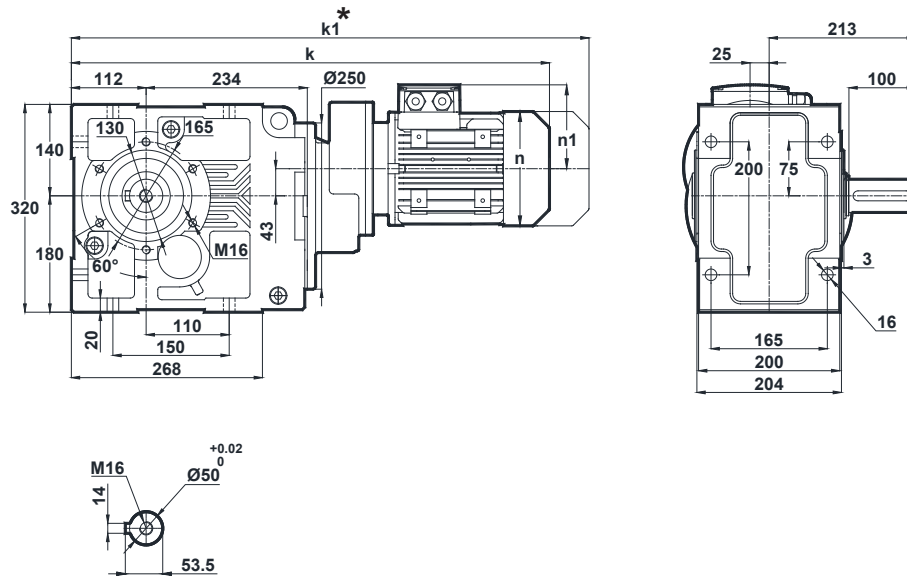

	71	80
k	646	680
k1	737	773
n	137	155
n1	112	121

\* "k1" Ölçüsü frenli redüktörlere aittir.  
Dimension "k1" is for motors with brake.  
Maße "k1" ist für Bremsenmotoren.

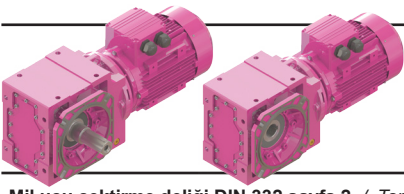

# Ölçü Sayfaları

## Dimension Pages

### Abmessungsseiten

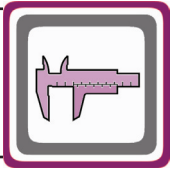

-Mil ucu çekirme deliği DIN 332 sayfa 2 / Tapped center hole to DIN 332, sheet 2 / Zentrierung mit Gewinde DIN 332, Blatt 2

#### KR474.02

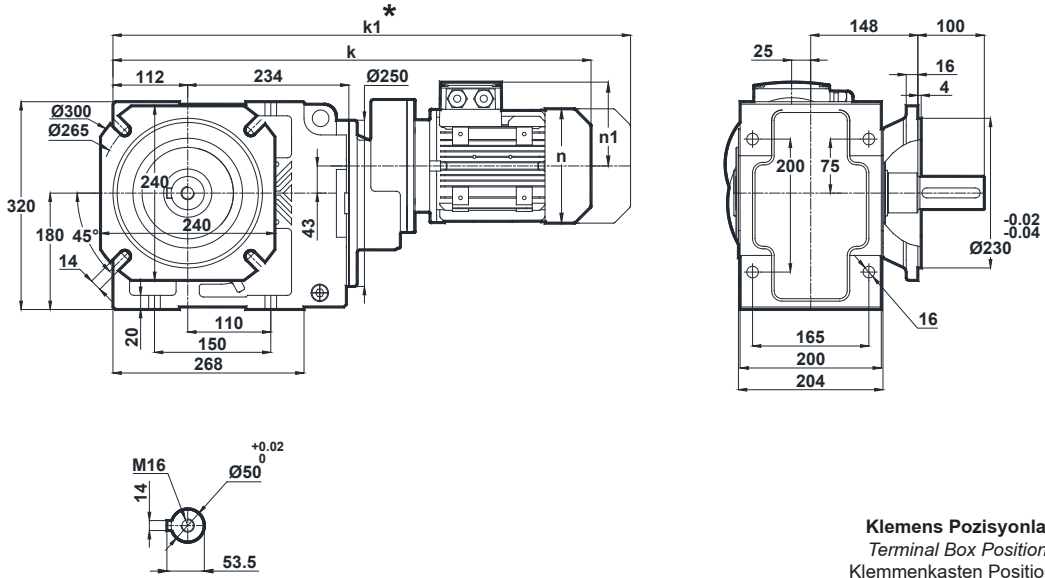

	71	80
k	646	680
k1	737	773
n	137	155
n1	112	121

Klemens Pozisyonları  
Terminal Box Positions  
Klemmenkasten Positionen

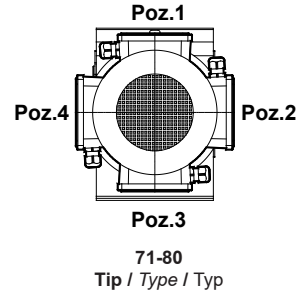

#### KR474.03

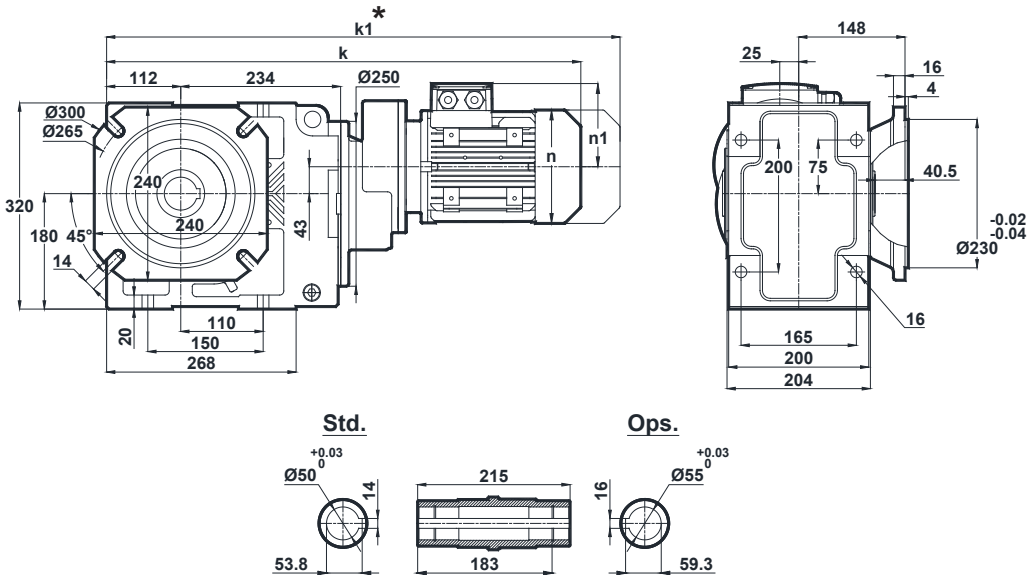

	71	80
k	646	680
k1	737	773
n	137	155
n1	112	121

\* "k1" Ölçüsü frenli redüktörlere aittir.  
Dimension "k1" is for motors with brake.  
Maße "k1" ist für Bremsenmotoren.

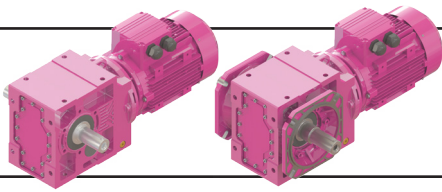

# Ölçü Sayfaları

## Dimension Pages

### Abmessungsseiten

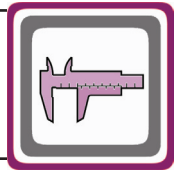

-Mil ucu çektirme deliği DIN 332 sayfa 2 / Tapped center hole to DIN 332, sheet 2 / Zentrierung mit Gewinde DIN 332, Blatt 2

#### KR474.04

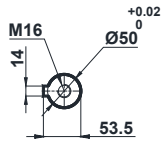
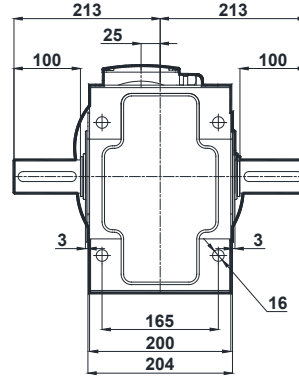
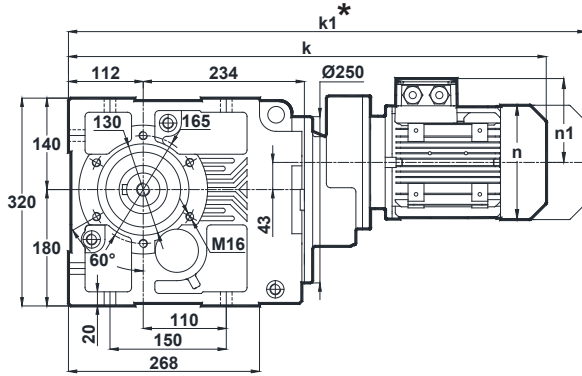

	71	80
k	646	680
k1	737	773
n	137	155
n1	112	121

**Klemens Pozisyonları**  
Terminal Box Positions  
Klemmenkasten Positionen

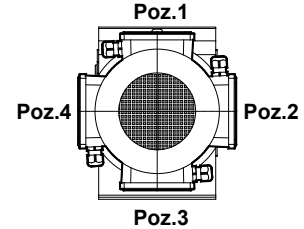

71-80  
Tip / Type / Typ

#### KR474.05

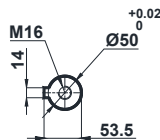
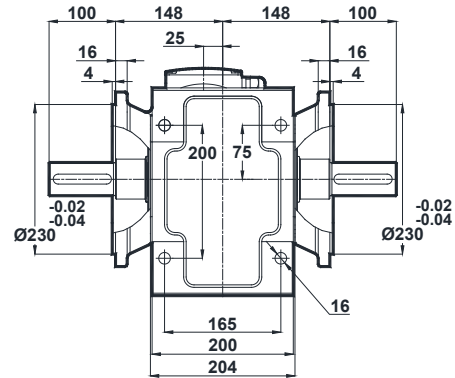
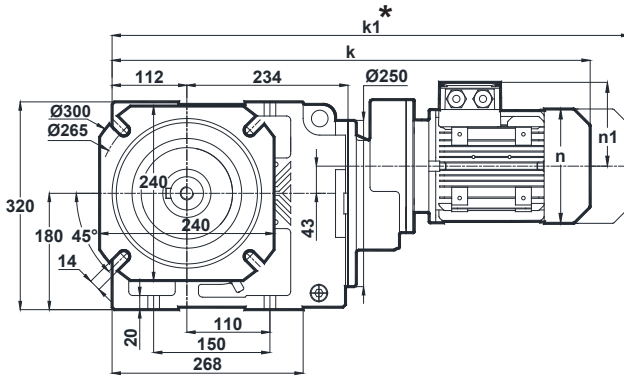

	71	80
k	646	680
k1	737	773
n	137	155
n1	112	121

\* " k1 " Ölçüsü frenli redüktörlere aittir.  
Dimension " k1 " is for motors with brake.  
Maße " k1 " ist für Bremsenmotoren.

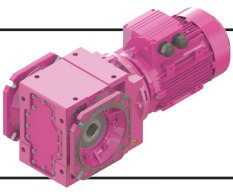

# Ölçü Sayfaları Dimension Pages Abmessungsseiten

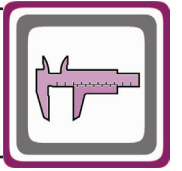

-Mil ucu çektirme deliği DIN 332 sayfa 2 / Tapped center hole to DIN 332, sheet 2 / Zentrierung mit Gewinde DIN 332, Blatt 2

KR474.08

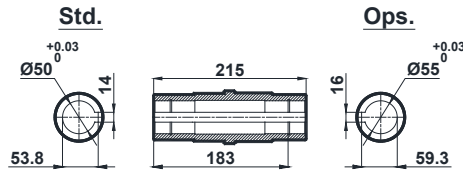
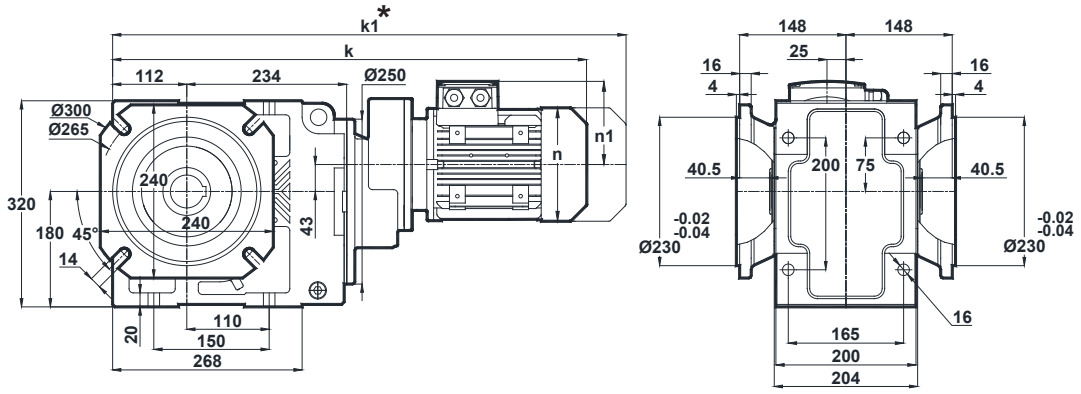

**Klemens Pozisyonları**  
Terminal Box Positions  
Klemmenkasten Positionen

	71	80
k	646	680
k1	737	773
n	137	155
n1	112	121

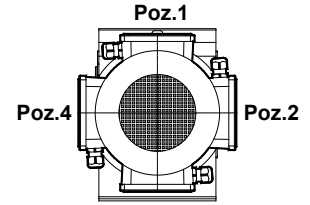

**Poz.3**

71-80

Tip / Type / Typ

\* "k1" Ölçüsü frenli redüktörlere aittir.  
Dimension "k1" is for motors with brake.  
Maße "k1" ist für Bremsenmotoren.

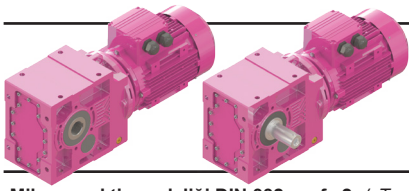

# Ölçü Sayfaları

## Dimension Pages

### Abmessungsseiten

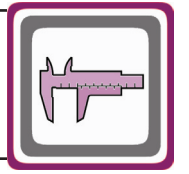

-Mil ucu çektirme deliği DIN 332 sayfa 2 / Tapped center hole to DIN 332, sheet 2 / Zentrierung mit Gewinde DIN 332, Blatt 2

KR475.00  
KR476.00

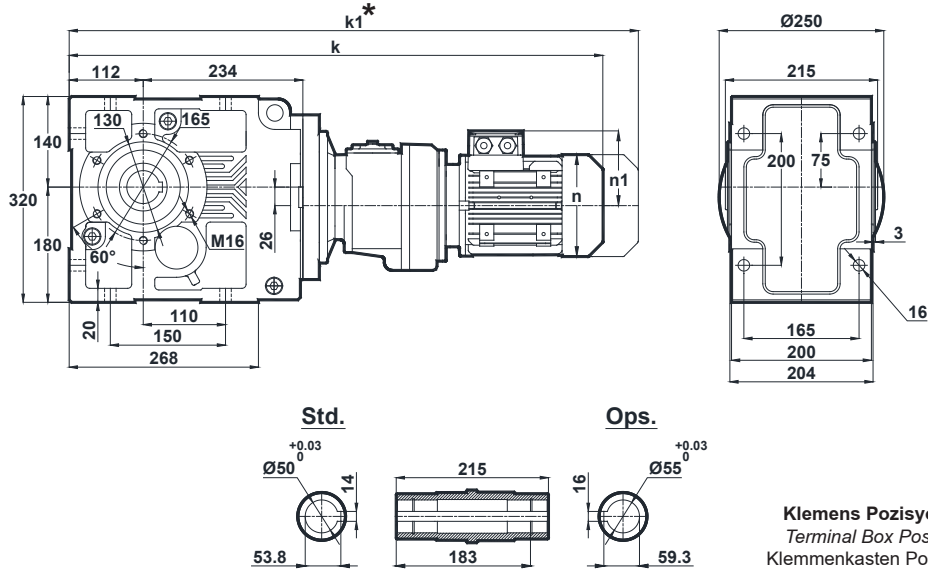

**Klemens Pozisyonları**  
Terminal Box Positions  
Klemmenkasten Positionen

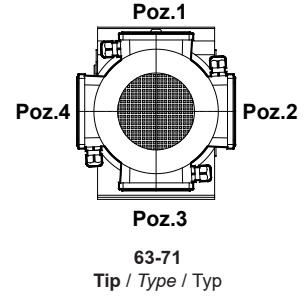

	63	71
k	748	776
k1	809	867
n	121	137
n1	97	112

KR475.01  
KR476.01

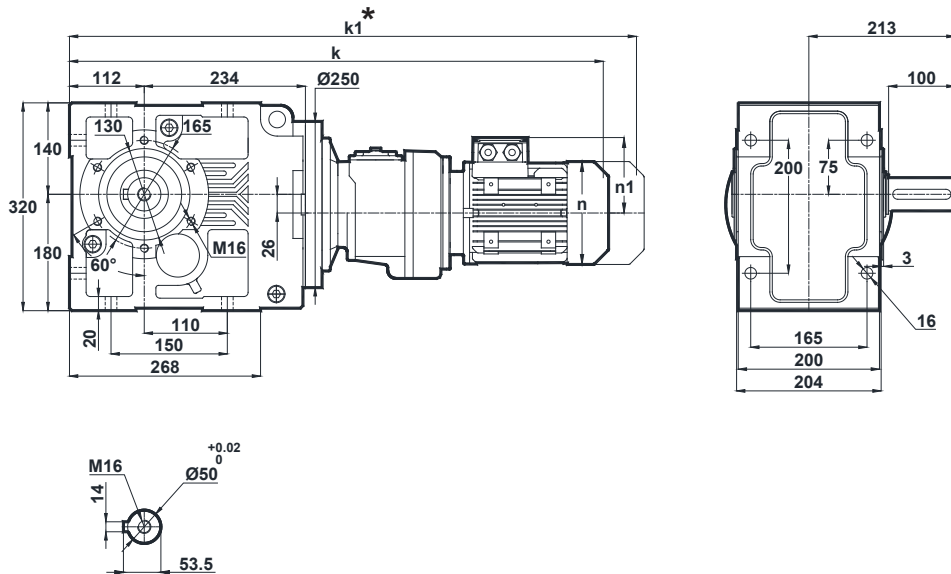

	63	71
k	748	776
k1	809	867
n	121	137
n1	97	112

\* " k1 " Ölçüsü frenli redüktörlere aittir.  
Dimension " k1 " is for motors with brake.  
Maße " k1 " ist für Bremsenmotoren.

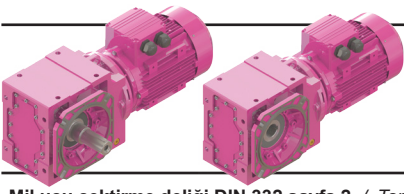

# Ölçü Sayfaları

## Dimension Pages

### Abmessungsseiten

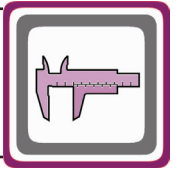

-Mil ucu çektirme deliği DIN 332 sayfa 2 / Tapped center hole to DIN 332, sheet 2 / Zentrierung mit Gewinde DIN 332, Blatt 2

KR475.02  
KR476.02

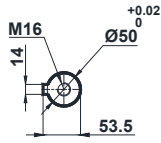
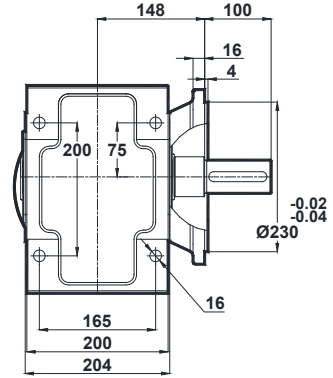
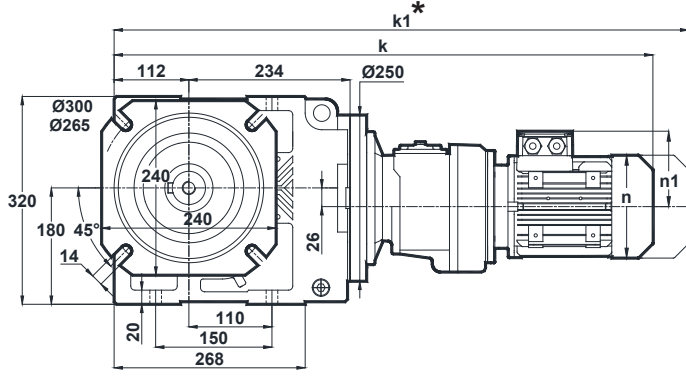

	63	71
k	748	776
k1	809	867
n	121	137
n1	97	112

Klemens Pozisyonları  
Terminal Box Positions  
Klemmenkasten Positionen

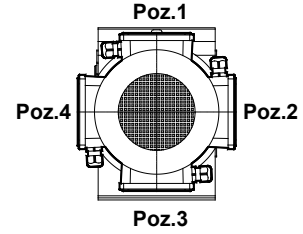

63-71  
Tip / Type / Typ

KR475.03  
KR476.03

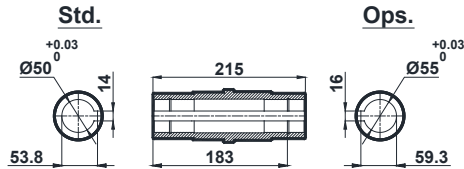
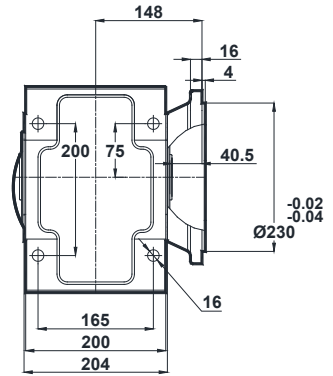
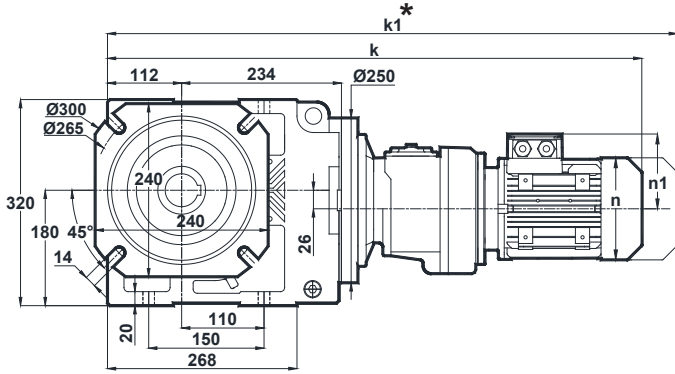

	63	71
k	748	776
k1	809	867
n	121	137
n1	97	112

\* " k1 " Ölçüsü frenli redüktörlere aittir.  
Dimension " k1 " is for motors with brake.  
Maße " k1 " ist für Bremsenmotoren.

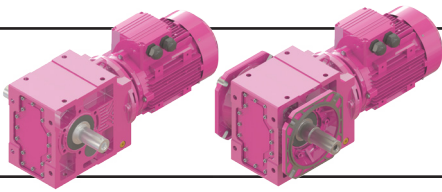

# Ölçü Sayfaları

## Dimension Pages

### Abmessungsseiten

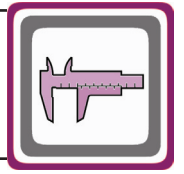

-Mil ucu çektirme deliği DIN 332 sayfa 2 / Tapped center hole to DIN 332, sheet 2 / Zentrierung mit Gewinde DIN 332, Blatt 2

KR475.04  
KR476.04

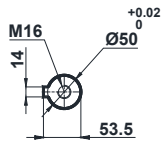
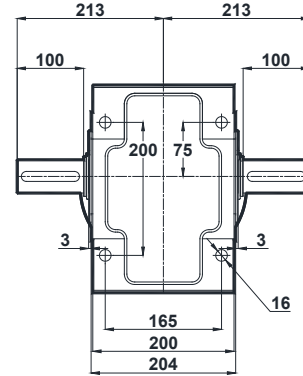
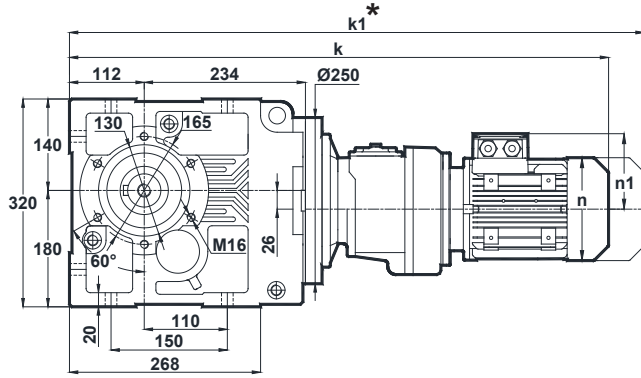

	63	71
k	748	776
k1	809	867
n	121	137
n1	97	112

Klemens Pozisyonları  
Terminal Box Positions  
Klemmenkasten Positionen

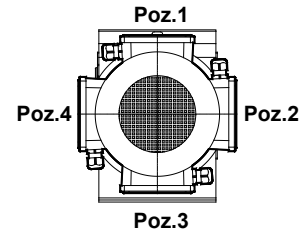

63-71  
Tip / Type / Typ

KR475.05  
KR476.05

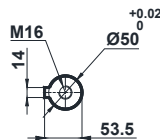
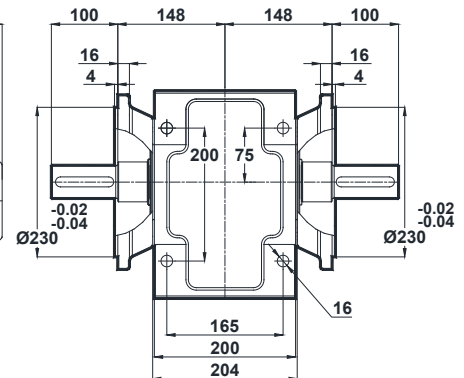
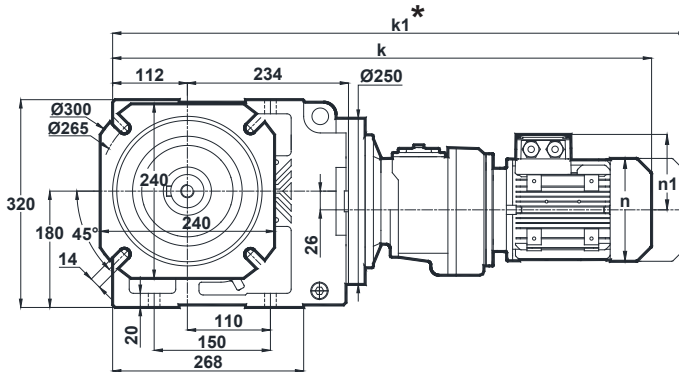

	63	71
k	748	776
k1	809	867
n	121	137
n1	97	112

\* " k1 " Ölçüsü frenli redüktörlere aittir.  
Dimension " k1 " is for motors with brake.  
Maße " k1 " ist für Bremsenmotoren.



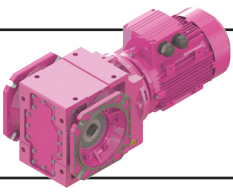

# Ölçü Sayfaları

## Dimension Pages

### Abmessungsseiten

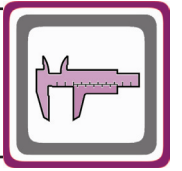

-Mil ucu çektirme deliği DIN 332 sayfa 2 / Tapped center hole to DIN 332, sheet 2 / Zentrierung mit Gewinde DIN 332, Blatt 2

KR475.08  
KR476.08

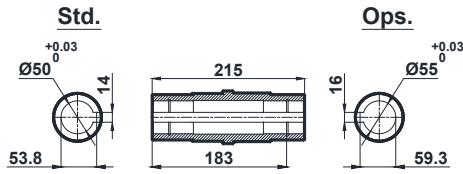
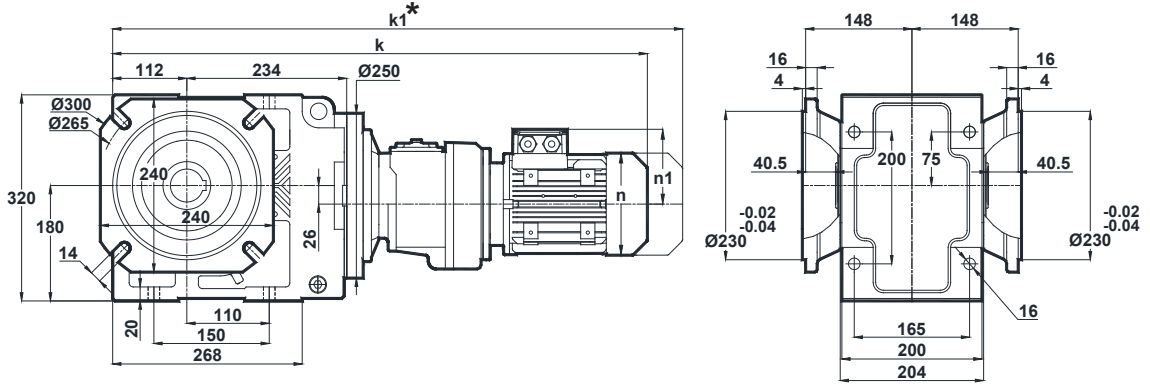

**Klemens Pozisyonları**  
Terminal Box Positions  
Klemmenkasten Positionen

	63	71
k	748	776
k1	809	867
n	121	137
n1	97	112

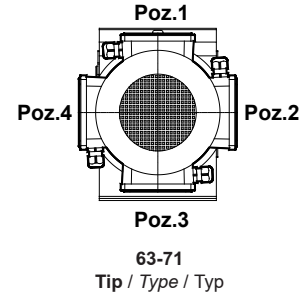

63-71  
Tip / Type / Typ

\* "k1" Ölçüsü frenli redüktörlere aittir.  
Dimension "k1" is for motors with brake.  
Maße "k1" ist für Bremsenmotoren.

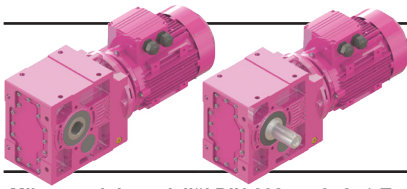

# Ölçü Sayfaları

## Dimension Pages

### Abmessungsseiten

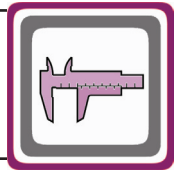

-Mil ucu çektirme deliği DIN 332 sayfa 2 / Tapped center hole to DIN 332, sheet 2 / Zentrierung mit Gewinde DIN 332, Blatt 2

#### KR573.00

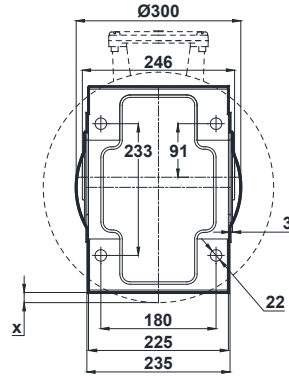
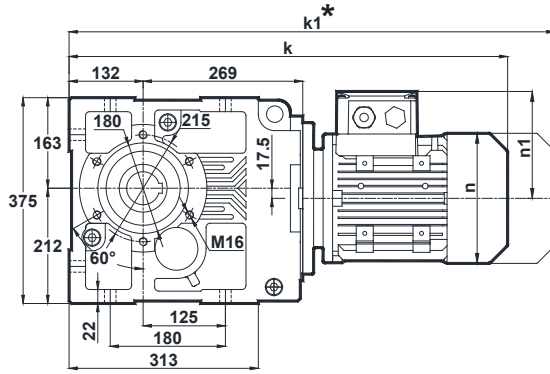

**Std.**

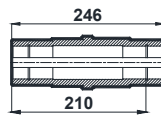
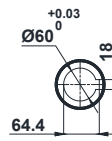

**Ops.**

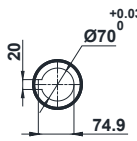

x: Motor Ayak bağlantı yüzeyinin altında ise  
x: If Motor is lower than foot mounting plane  
x: Wenn der Motor unter der Fußmontageebene ist

**Klemens Pozisyonları**  
Terminal Box Positions  
Klemmenkasten Positionen

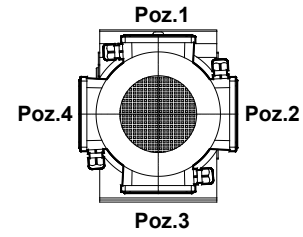

100-112-132-160-180  
Tip / Type / Typ

	100L	112M	132S	132M	160M	160L	180M	180L
k	719	743	830	830	926	926	997	997
k1	838.5	847.5	960	960	1106	1106	1167.5	1167.5
n	193	215	257	257	315	315	347	347
n1	147	158	179	179	219	219	234	234
x	-	-	-	-	-	-	-	-

#### KR573.01

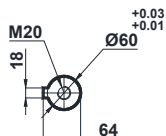
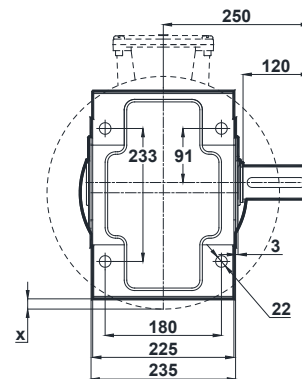
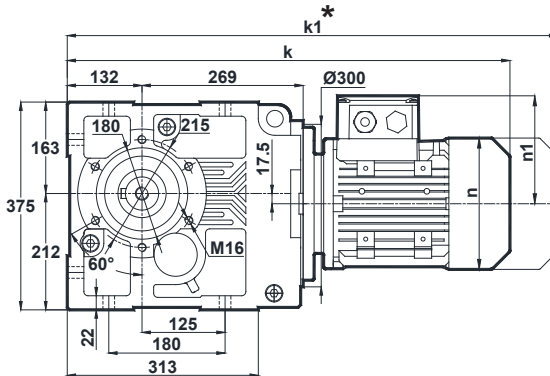

x: Motor Ayak bağlantı yüzeyinin altında ise  
x: If Motor is lower than foot mounting plane  
x: Wenn der Motor unter der Fußmontageebene ist

	100L	112M	132S	132M	160M	160L	180M	180L
k	719	743	830	830	926	926	997	997
k1	838.5	847.5	960	960	1106	1106	1167.5	1167.5
n	193	215	257	257	315	315	347	347
n1	147	158	179	179	219	219	234	234
x	-	-	-	-	-	-	-	-

\* "k1" Ölçüsü frenli redüktörlere aittir.  
Dimension "k1" is for motors with brake.  
Maße "k1" ist für Bremsenmotoren.

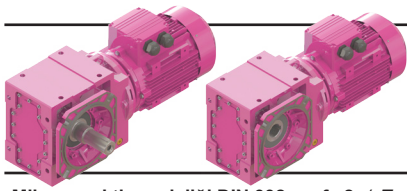

# Ölçü Sayfaları Dimension Pages Abmessungsseiten

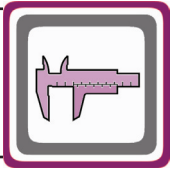

-Mil ucu çektirme deliği DIN 332 sayfa 2 / Tapped center hole to DIN 332, sheet 2 / Zentrierung mit Gewinde DIN 332, Blatt 2

## KR573.02

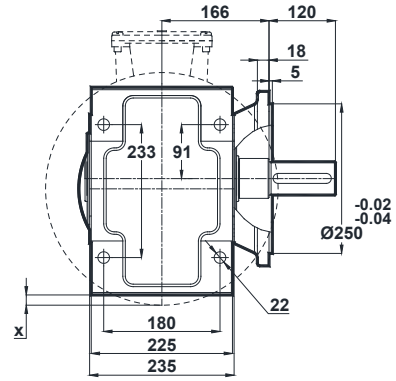
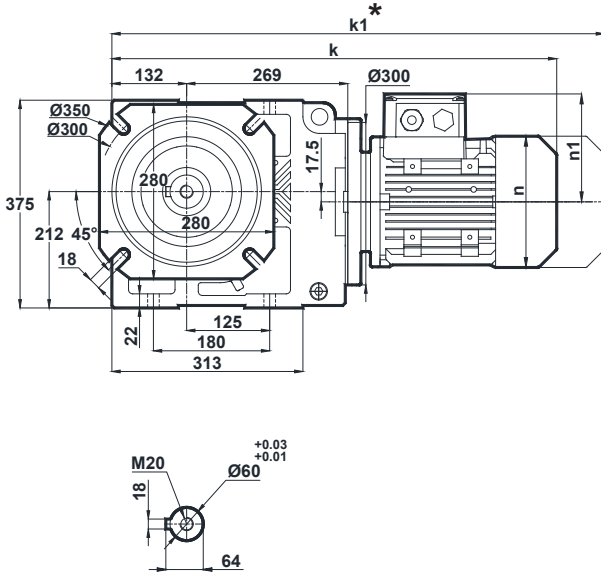

x: Motor Ayak bağlantı yüzeyinin altında ise  
x: If Motor is lower than foot mounting plane  
x: Wenn der Motor unter der Fußmontageebene ist

**Klemens Pozisyonları**  
Terminal Box Positions  
Klemmenkasten Positionen

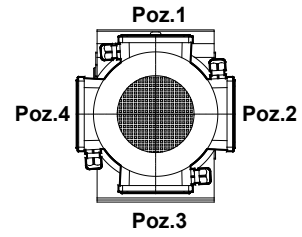

100-112-132-160-180  
Tip / Type / Typ

	100L	112M	132S	132M	160M	160L	180M	180L
k	719	743	830	830	926	926	997	997
k1	838.5	847.5	960	960	1106	1106	1167.5	1167.5
n	193	215	257	257	315	315	347	347
n1	147	158	179	179	219	219	234	234
x	-	-	-	-	-	-	-	-

## KR573.03

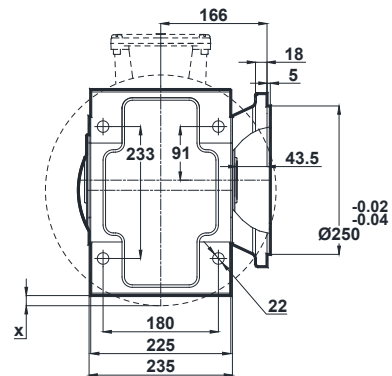
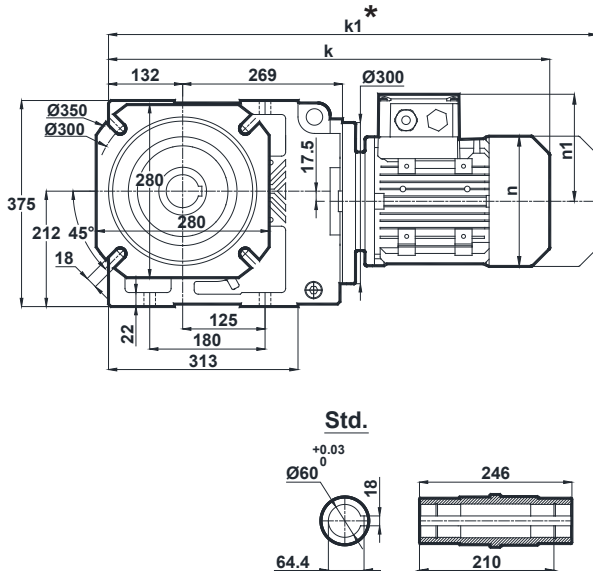

x: Motor Ayak bağlantı yüzeyinin altında ise  
x: If Motor is lower than foot mounting plane  
x: Wenn der Motor unter der Fußmontageebene ist

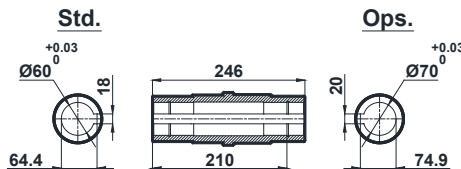

	100L	112M	132S	132M	160M	160L	180M	180L
k	719	743	830	830	926	926	997	997
k1	838.5	847.5	960	960	1106	1106	1167.5	1167.5
n	193	215	257	257	315	315	347	347
n1	147	158	179	179	219	219	234	234
x	-	-	-	-	-	-	-	-

\* "k1" Ölçüsü frenli redüktörlere aittir.  
Dimension "k1" is for motors with brake.  
Maße "k1" ist für Bremsenmotoren.

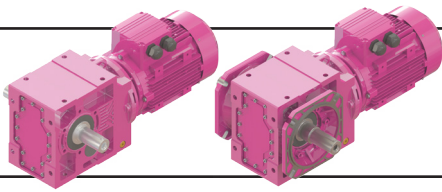

# Ölçü Sayfaları

## Dimension Pages

### Abmessungsseiten

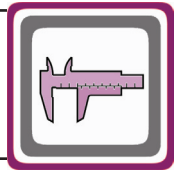

-Mil ucu çekirme deliği DIN 332 sayfa 2 / Tapped center hole to DIN 332, sheet 2 / Zentrierung mit Gewinde DIN 332, Blatt 2

#### KR573.04

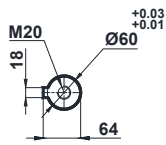
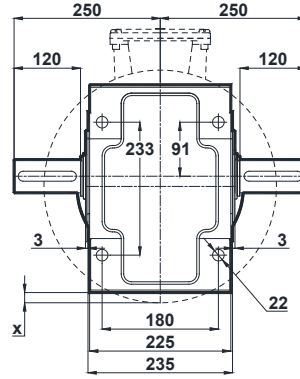
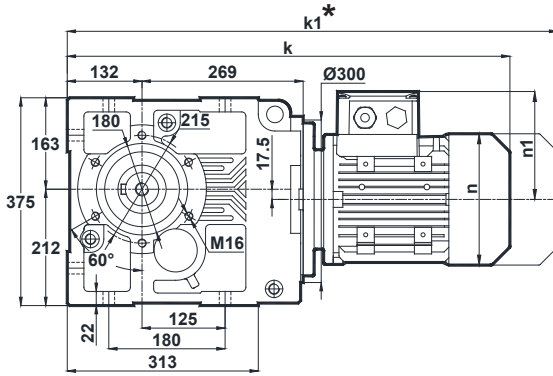

x: Motor Ayak bağlantı yüzeyinin altında ise  
x: If Motor is lower than foot mounting plane  
x: Wenn der Motor unter der Fußmontageebene ist

**Klemens Pozisyonları**  
Terminal Box Positions  
Klemmenkasten Positionen

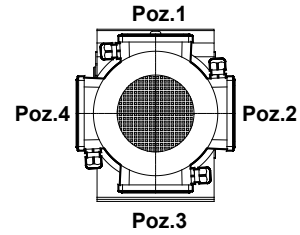

100-112-132-160-180  
Tip / Type / Typ

	100L	112M	132S	132M	160M	160L	180M	180L
k	719	743	830	830	926	926	997	997
k1	838.5	847.5	960	960	1106	1106	1167.5	1167.5
n	193	215	257	257	315	315	347	347
n1	147	158	179	179	219	219	234	234
x	-	-	-	-	-	-	-	-

#### KR573.05

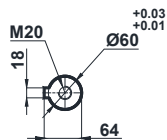
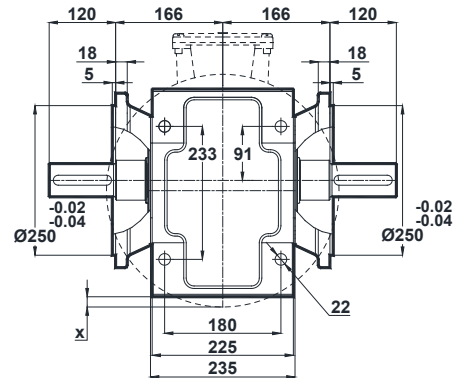
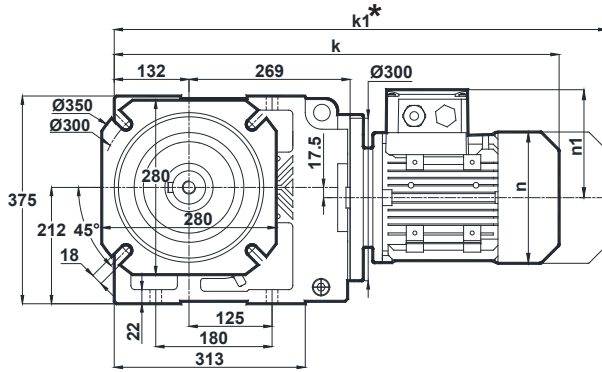

x: Motor Ayak bağlantı yüzeyinin altında ise  
x: If Motor is lower than foot mounting plane  
x: Wenn der Motor unter der Fußmontageebene ist

	100L	112M	132S	132M	160M	160L	180M	180L
k	719	743	830	830	926	926	997	997
k1	838.5	847.5	960	960	1106	1106	1167.5	1167.5
n	193	215	257	257	315	315	347	347
n1	147	158	179	179	219	219	234	234
x	-	-	-	-	-	-	-	-

\* "k1" Ölçüsü frenli redüktörlere aittir.  
Dimension "k1" is for motors with brake.  
Maße "k1" ist für Bremsenmotoren.

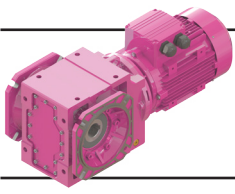

# Ölçü Sayfaları Dimension Pages Abmessungsseiten

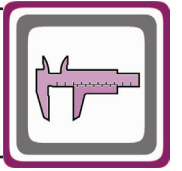

-Mil ucu çektirme deliği DIN 332 sayfa 2 / Tapped center hole to DIN 332, sheet 2 / Zentrierung mit Gewinde DIN 332, Blatt 2

KR573.08

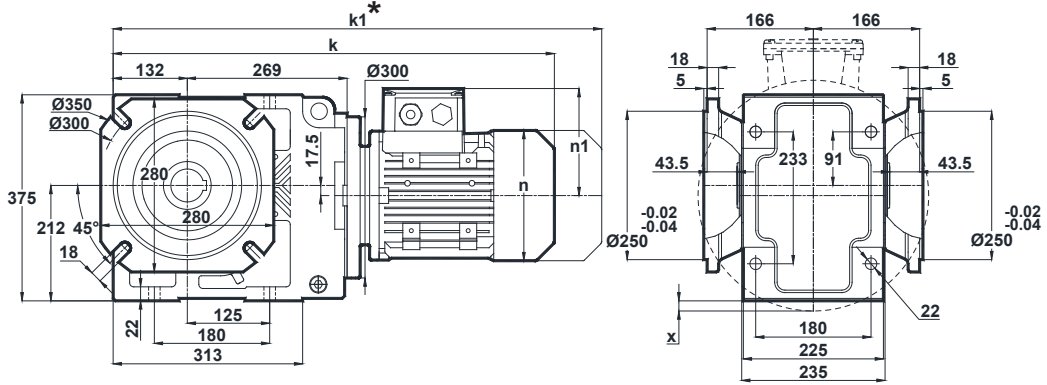

Std.

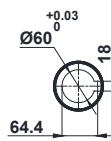

Ops.

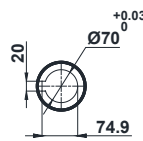

x: Motor Ayak bağlantı yüzeyinin altında ise  
x: If Motor is lower than foot mounting plane  
x: Wenn der Motor unter der Fußmontageebene ist

	100L	112M	132S	132M	160M	160L	180M	180L
k	719	743	830	830	926	926	997	997
k1	838.5	847.5	960	960	1106	1106	1167.5	1167.5
n	193	215	257	257	315	315	347	347
n1	147	158	179	179	219	219	234	234
x	-	-	-	-	-	-	-	-

Klemens Pozisyonları  
Terminal Box Positions  
Klemmenkasten Positionen

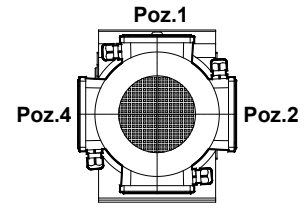

Poz.3

100-112-132-160-180  
Tip / Type / Typ

\* "k1" Ölçüsü frenli redüktörlere aittir.  
Dimension "k1" is for motors with brake.  
Maße "k1" ist für Bremsenmotoren.

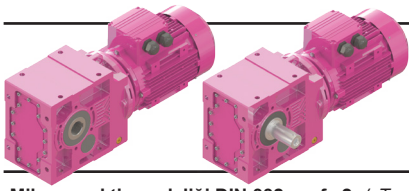

# Ölçü Sayfaları

## Dimension Pages

### Abmessungsseiten

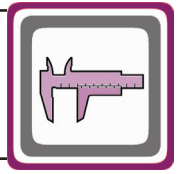

-Mil ucu çektirme deliği DIN 332 sayfa 2 / Tapped center hole to DIN 332, sheet 2 / Zentrierung mit Gewinde DIN 332, Blatt 2

#### KR574.00

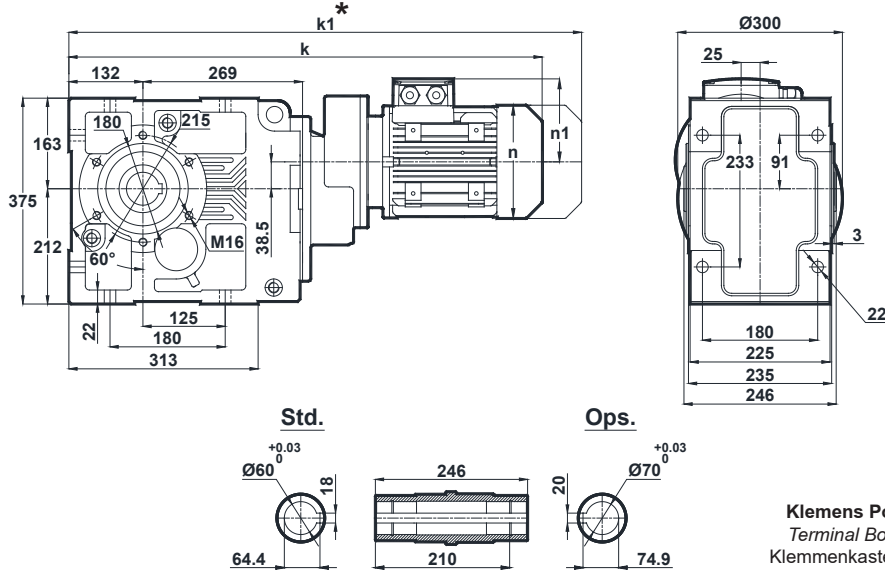

	71	80	90S	90L	100L
k	699	733	772	772	820
k1	790	826	876.5	876.5	939.5
n	137	155	176	176	193
n1	112	121	132	132	147

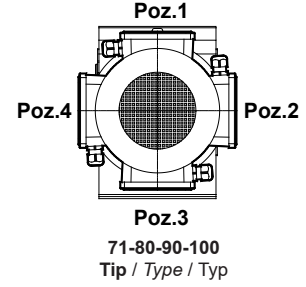

#### KR574.01

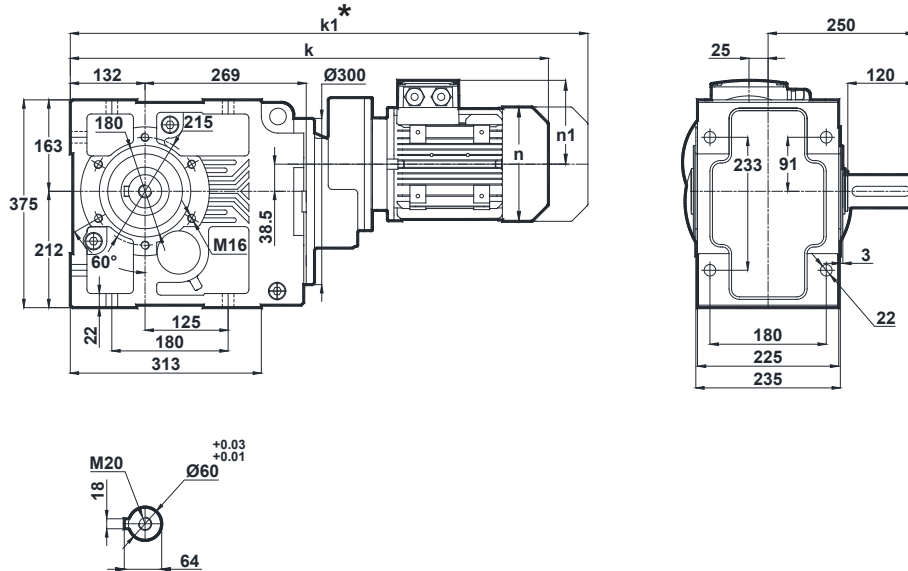

	71	80	90S	90L	100L
k	699	733	772	772	820
k1	790	826	876.5	876.5	939.5
n	137	155	176	176	193
n1	112	121	132	132	147

\* "k1" Ölçüsü frenli redüktörlere aittir.  
Dimension "k1" is for motors with brake.  
Maße "k1" ist für Bremsenmotoren.

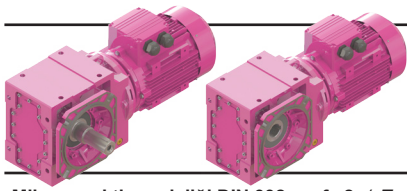

# Ölçü Sayfaları

## Dimension Pages

### Abmessungsseiten

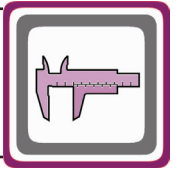

-Mil ucu çektirme deliği DIN 332 sayfa 2 / Tapped center hole to DIN 332, sheet 2 / Zentrierung mit Gewinde DIN 332, Blatt 2

#### KR574.02

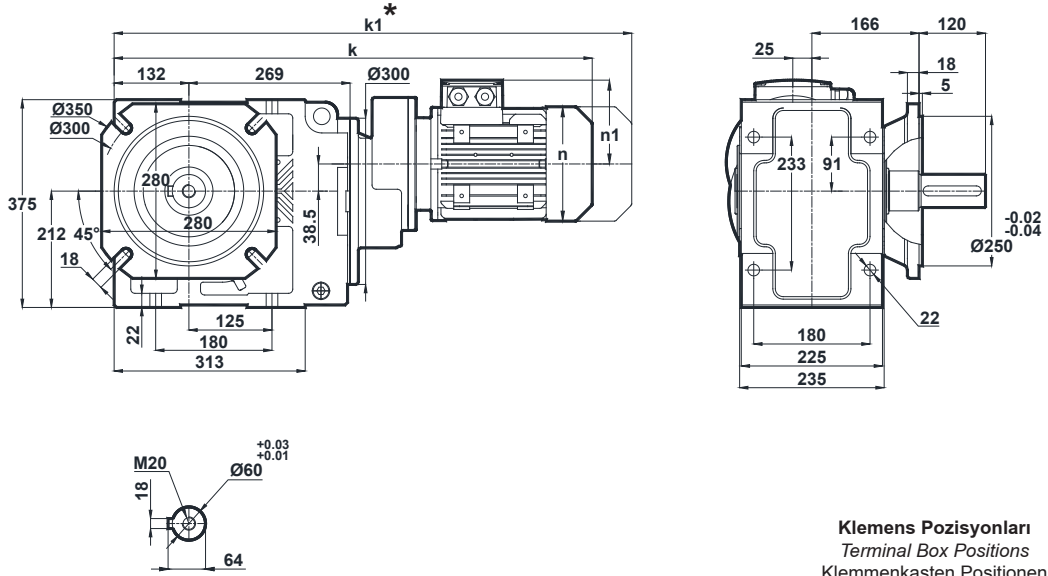

	71	80	90S	90L	100L
k	699	733	772	772	820
k1	790	826	876.5	876.5	939.5
n	137	155	176	176	193
n1	112	121	132	132	147

**Klemens Pozisyonları**  
Terminal Box Positions  
Klemmenkasten Positionen

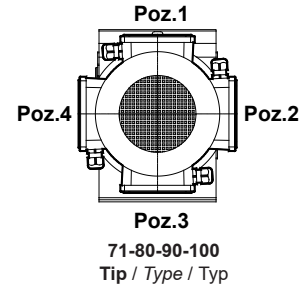

#### KR574.03

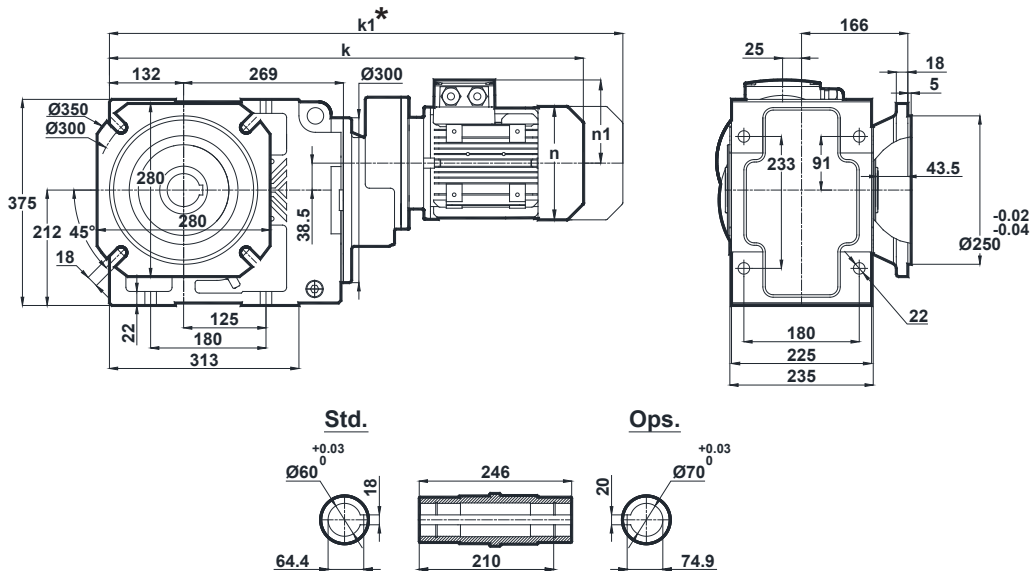

	71	80	90S	90L	100L
k	699	733	772	772	820
k1	790	826	876.5	876.5	939.5
n	137	155	176	176	193
n1	112	121	132	132	147

\* "k1" Ölçüsü frenli redüktörlere aittir.  
Dimension "k1" is for motors with brake.  
Maße "k1" ist für Bremsenmotoren.

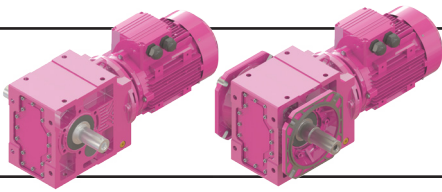

# Ölçü Sayfaları

## Dimension Pages

### Abmessungsseiten

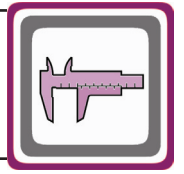

-Mil ucu çektirme deliği DIN 332 sayfa 2 / Tapped center hole to DIN 332, sheet 2 / Zentrierung mit Gewinde DIN 332, Blatt 2

#### KR574.04

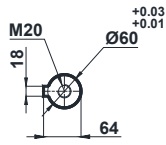
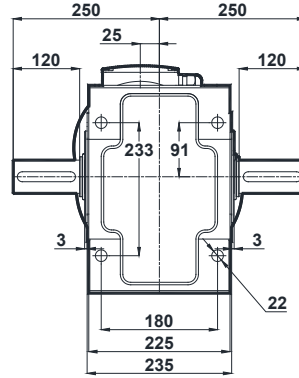
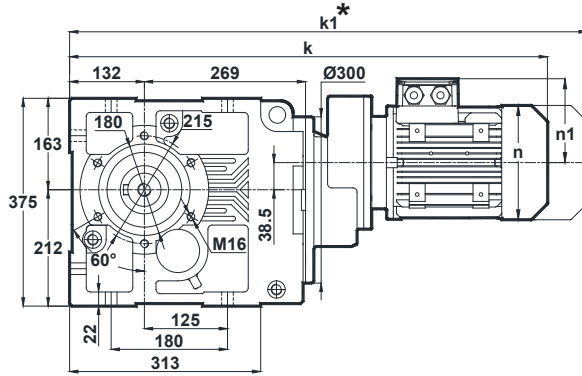

**Klemens Pozisyonları**  
Terminal Box Positions  
Klemmenkasten Positionen

	71	80	90S	90L	100L
k	699	733	772	772	820
k1	790	826	876.5	876.5	939.5
n	137	155	176	176	193
n1	112	121	132	132	147

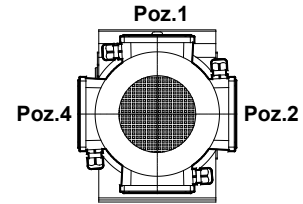

**Poz.3**  
71-80-90-100  
Tip / Type / Typ

#### KR574.05

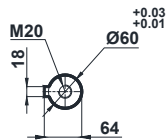
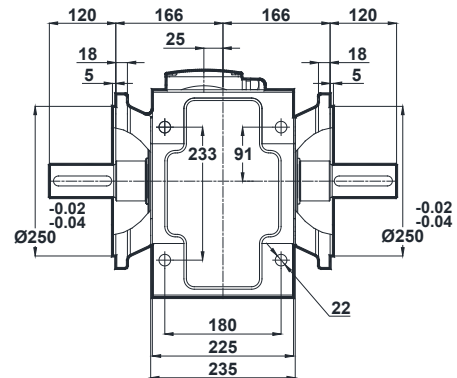
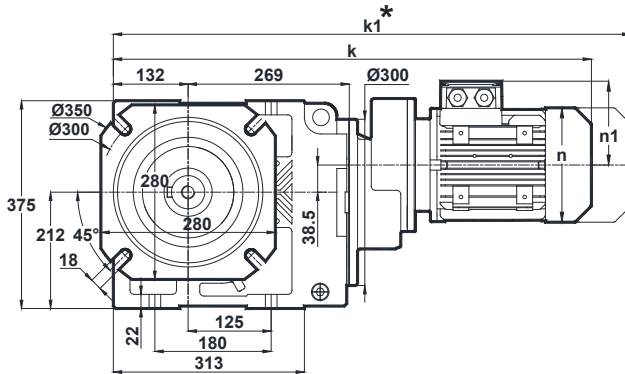

	71	80	90S	90L	100L
k	699	733	772	772	820
k1	790	826	876.5	876.5	939.5
n	137	155	176	176	193
n1	112	121	132	132	147

\* "k1" Ölçüsü frenli redüktörlere aittir.  
Dimension "k1" is for motors with brake.  
Maße "k1" ist für Bremsenmotoren.



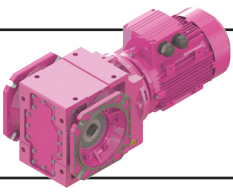

# Ölçü Sayfaları Dimension Pages Abmessungsseiten

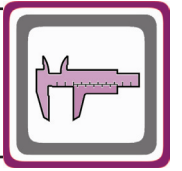

-Mil ucu çektirme deliği DIN 332 sayfa 2 / Tapped center hole to DIN 332, sheet 2 / Zentrierung mit Gewinde DIN 332, Blatt 2

KR574.08

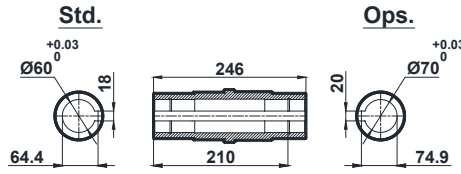
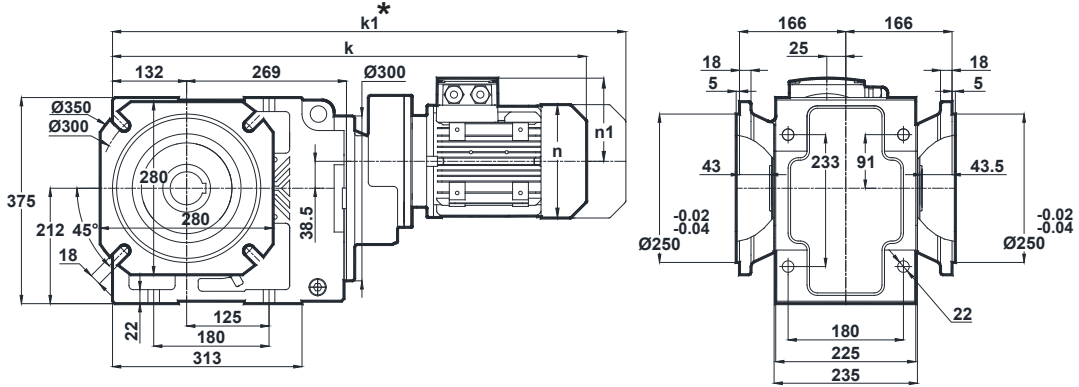

Klemens Pozisyonları  
Terminal Box Positions  
Klemmenkasten Positionen

	71	80	90S	90L	100L
k	699	733	772	772	820
k1	790	826	876.5	876.5	939.5
n	137	155	176	176	193
n1	112	121	132	132	147

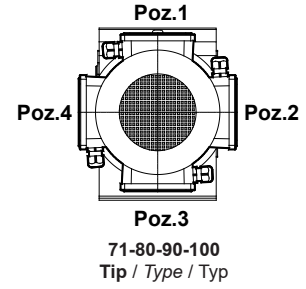

\* "k1" Ölçüsü frenli redüktörlere aittir.  
Dimension "k1" is for motors with brake.  
Maße "k1" ist für Bremsenmotoren.

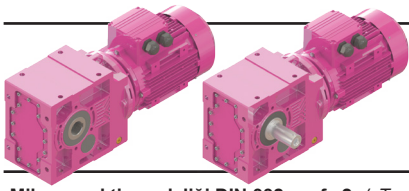

# Ölçü Sayfaları

## Dimension Pages

### Abmessungsseiten

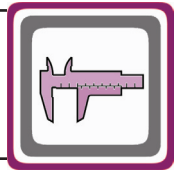

-Mil ucu çekirme deliği DIN 332 sayfa 2 / Tapped center hole to DIN 332, sheet 2 / Zentrierung mit Gewinde DIN 332, Blatt 2

KR575.00  
KR576.00

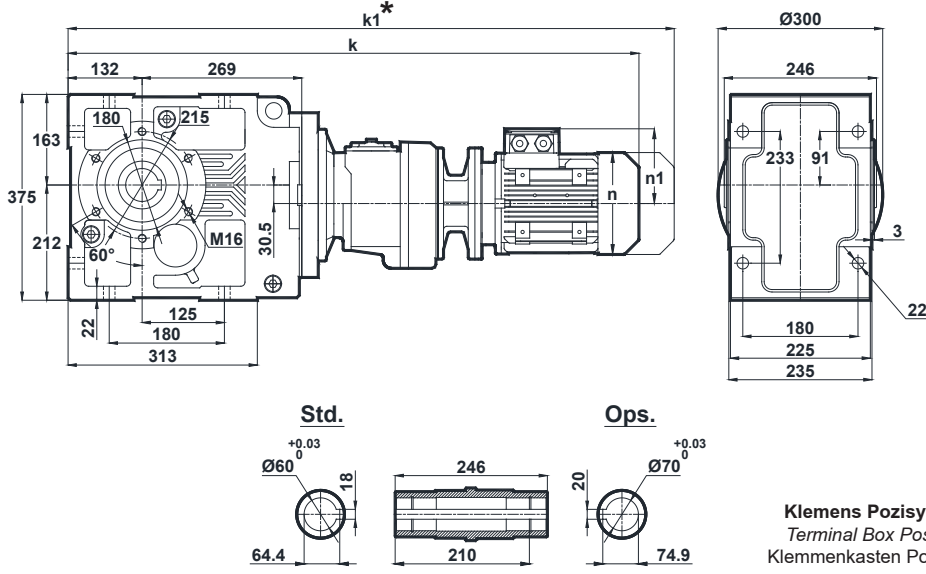

**Klemens Pozisyonları**  
Terminal Box Positions  
Klemmenkasten Positionen

	63	71	80
k	803	831	865
k1	864	922	958
n	121	137	155
n1	97	112	121

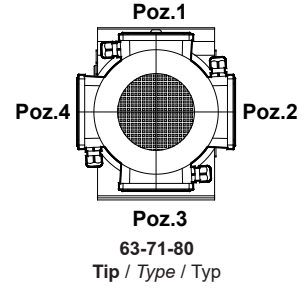

KR575.01  
KR576.01

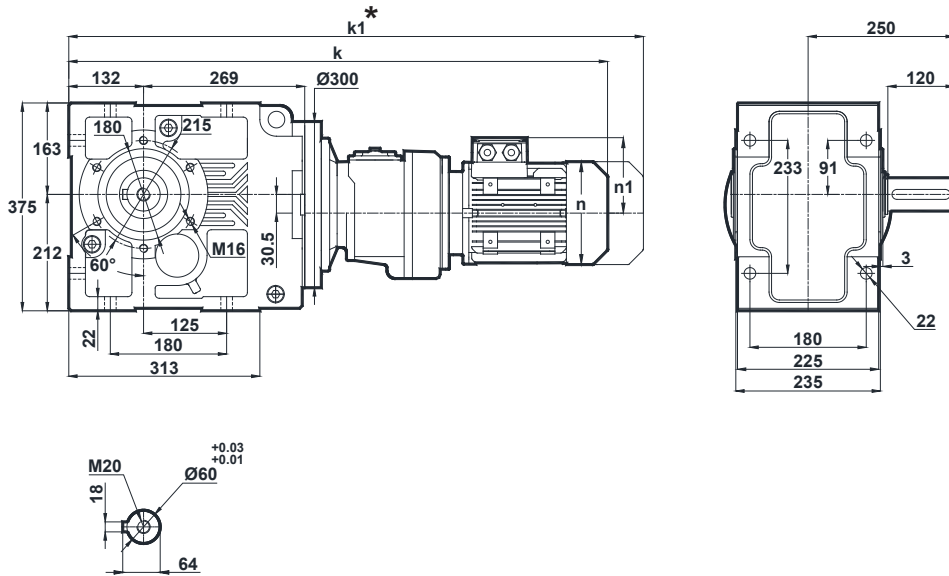

	63	71	80
k	803	831	865
k1	864	922	958
n	121	137	155
n1	97	112	121

\* "k1" Ölçüsü frenli redüktörlere aittir.  
Dimension "k1" is for motors with brake.  
Maße "k1" ist für Bremsenmotoren.

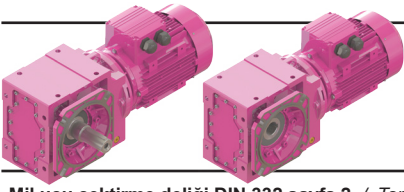

# Ölçü Sayfaları

## Dimension Pages

### Abmessungsseiten

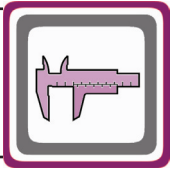

-Mil ucu çektirme deliği DIN 332 sayfa 2 / Tapped center hole to DIN 332, sheet 2 / Zentrierung mit Gewinde DIN 332, Blatt 2

KR575.02  
KR576.02

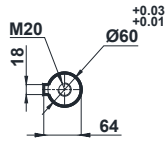
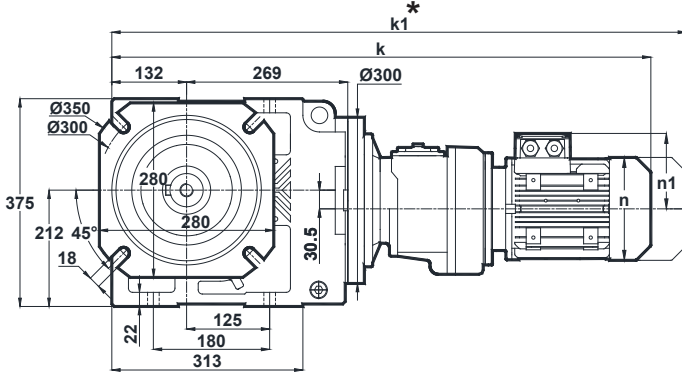

	63	71	80
k	803	831	865
k1	864	922	958
n	121	137	155
n1	97	112	121

Klemens Pozisyonları  
Terminal Box Positions  
Klemmenkasten Positionen

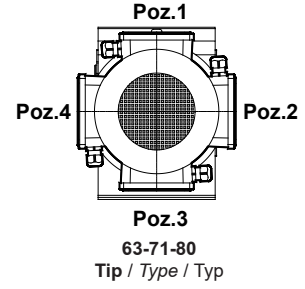

KR575.03  
KR576.03

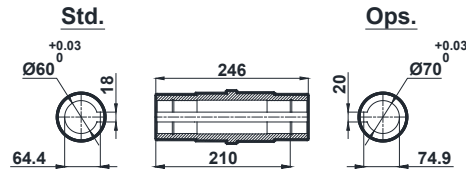
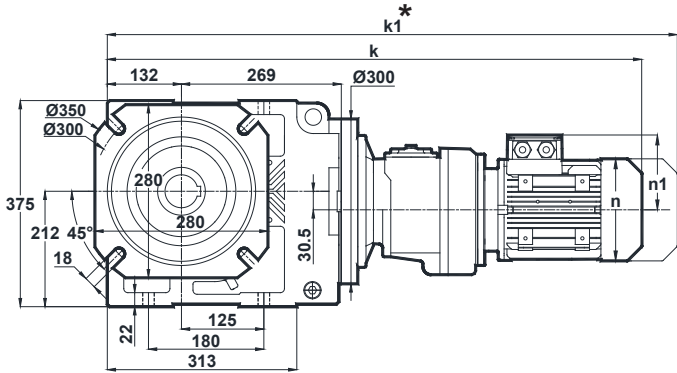

	63	71	80
k	803	831	865
k1	864	922	958
n	121	137	155
n1	97	112	121

\* "k1" Ölçüsü frenli redüktörlere aittir.  
Dimension "k1" is for motors with brake.  
Maße "k1" ist für Bremsenmotoren.

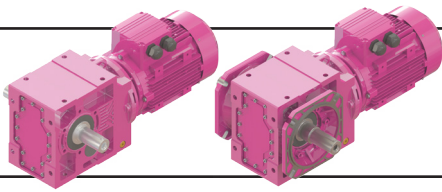

# Ölçü Sayfaları

## Dimension Pages

### Abmessungsseiten

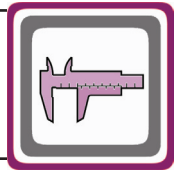

-Mil ucu çektirme deliği DIN 332 sayfa 2 / Tapped center hole to DIN 332, sheet 2 / Zentrierung mit Gewinde DIN 332, Blatt 2

KR575.04  
KR576.04

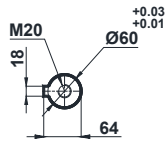
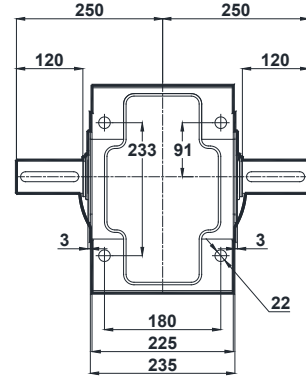
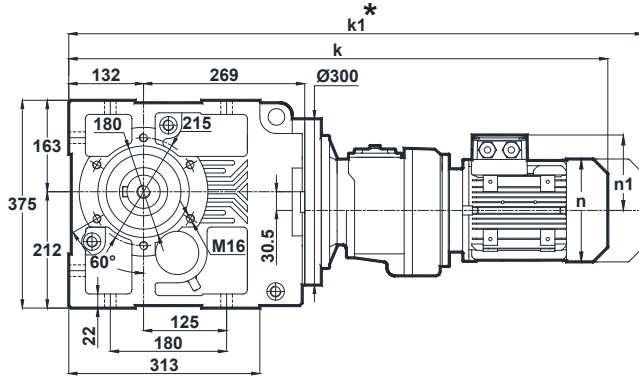

**Klemens Pozisyonları**  
Terminal Box Positions  
Klemmenkasten Positionen

	63	71	80
k	803	831	865
k1	864	922	958
n	121	137	155
n1	97	112	121

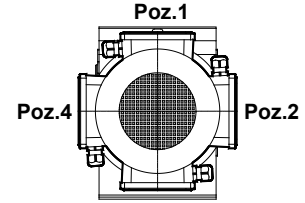

**Poz.3**  
63-71-80  
Tip / Type / Typ

KR575.05  
KR576.05

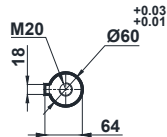
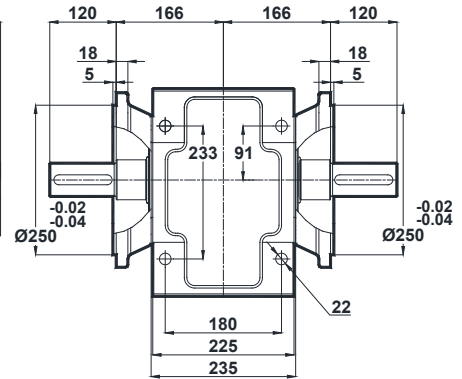
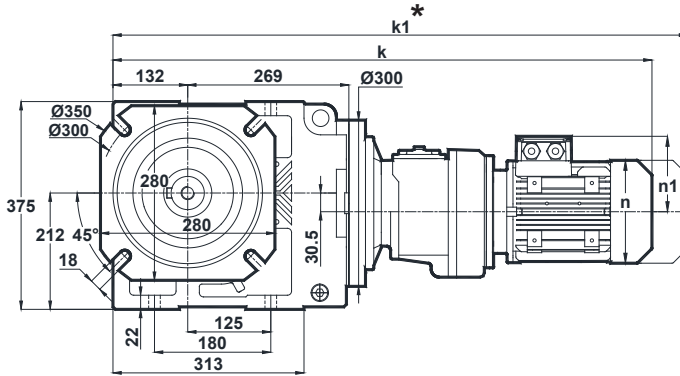

	63	71	80
k	803	831	865
k1	864	922	958
n	121	137	155
n1	97	112	121

\* "k1" Ölçüsü frenli redüktörlere aittir.  
Dimension "k1" is for motors with brake.  
Maße "k1" ist für Bremsenmotoren.

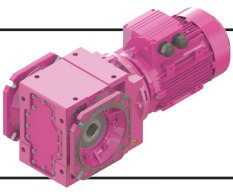

# Ölçü Sayfaları

## Dimension Pages

### Abmessungsseiten

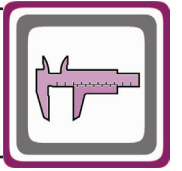

-Mil ucu çektirme deliği DIN 332 sayfa 2 / Tapped center hole to DIN 332, sheet 2 / Zentrierung mit Gewinde DIN 332, Blatt 2

KR575.08  
KR576.08

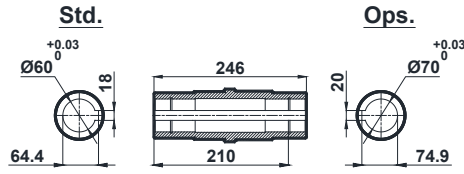
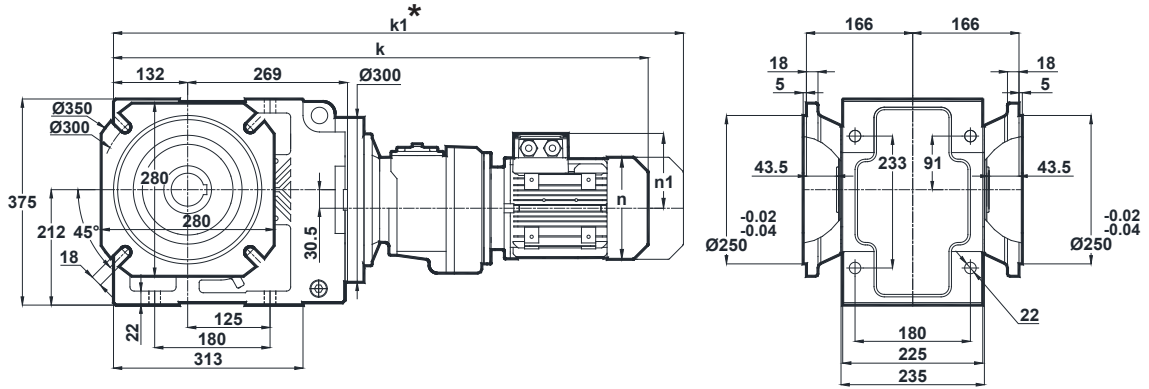

**Klemens Pozisyonları**  
Terminal Box Positions  
Klemmenkasten Positionen

	63	71	80
k	803	831	865
k1	864	922	958
n	121	137	155
n1	97	112	121

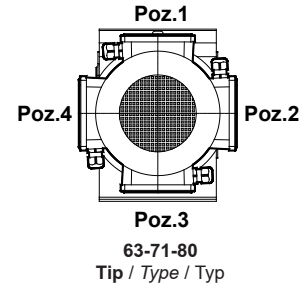

\* "k1" Ölçüsü frenli redüktörlere aittir.  
Dimension "k1" is for motors with brake.  
Maße "k1" ist für Bremsenmotoren.

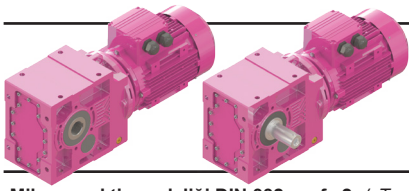

# Ölçü Sayfaları

## Dimension Pages

### Abmessungsseiten

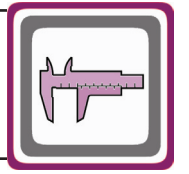

-Mil ucu çektirme deliği DIN 332 sayfa 2 / Tapped center hole to DIN 332, sheet 2 / Zentrierung mit Gewinde DIN 332, Blatt 2

#### KR673.00

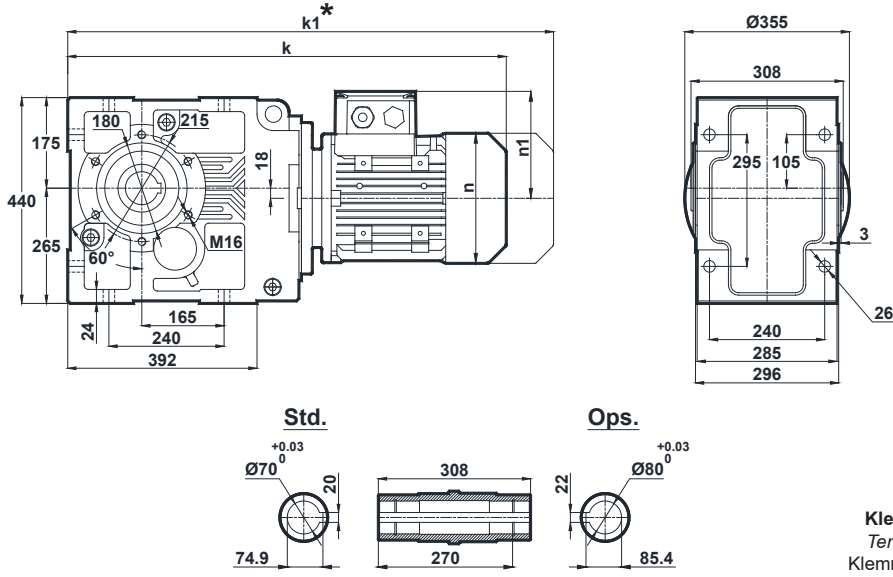

**Klemens Pozisyonları**  
Terminal Box Positions  
Klemmenkasten Positionen

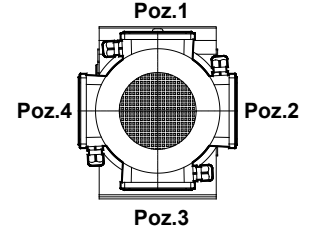

100-112-132-160-180-200-225  
Tip / Type / Typ

	100L	112M	132S	132M	160M	160L	180M	180L	200L	225S	225M
<b>k</b>	797	821	908	908	1004	1004	1075	1075	1117	1143	1168
<b>k1</b>	916.5	925.5	1038	1038	1184	1184	1245.5	1245.5	1303.5	1308	1333
<b>n</b>	193	215	257	257	315	315	347	347	390	434	434
<b>n1</b>	147	158	179	179	219	219	234	234	275	285	285

#### KR673.01

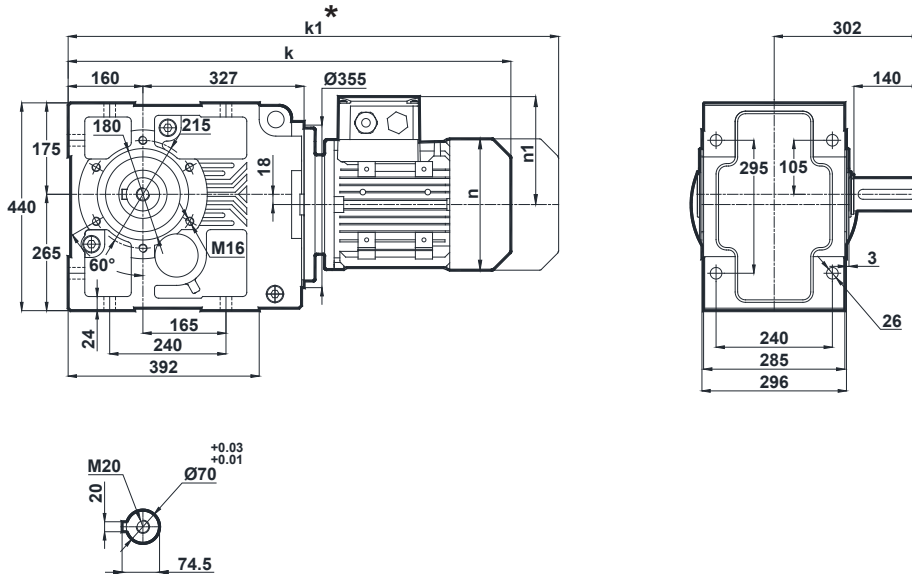

	100L	112M	132S	132M	160M	160L	180M	180L	200L	225S	225M
<b>k</b>	797	821	908	908	1004	1004	1075	1075	1117	1143	1168
<b>k1</b>	916.5	925.5	1038	1038	1184	1184	1245.5	1245.5	1303.5	1308	1333
<b>n</b>	193	215	257	257	315	315	347	347	390	434	434
<b>n1</b>	147	158	179	179	219	219	234	234	275	285	285

\* "k1" Ölçüsü frenli redüktörlere aittir.  
Dimension "k1" is for motors with brake.  
Maße "k1" ist für Bremsenmotoren.

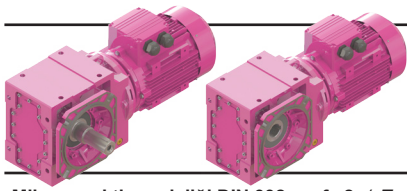

# Ölçü Sayfaları Dimension Pages Abmessungsseiten

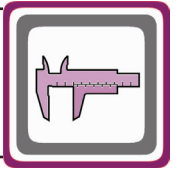

-Mil ucu çektirme deliği DIN 332 sayfa 2 / Tapped center hole to DIN 332, sheet 2 / Zentrierung mit Gewinde DIN 332, Blatt 2

## KR673.02

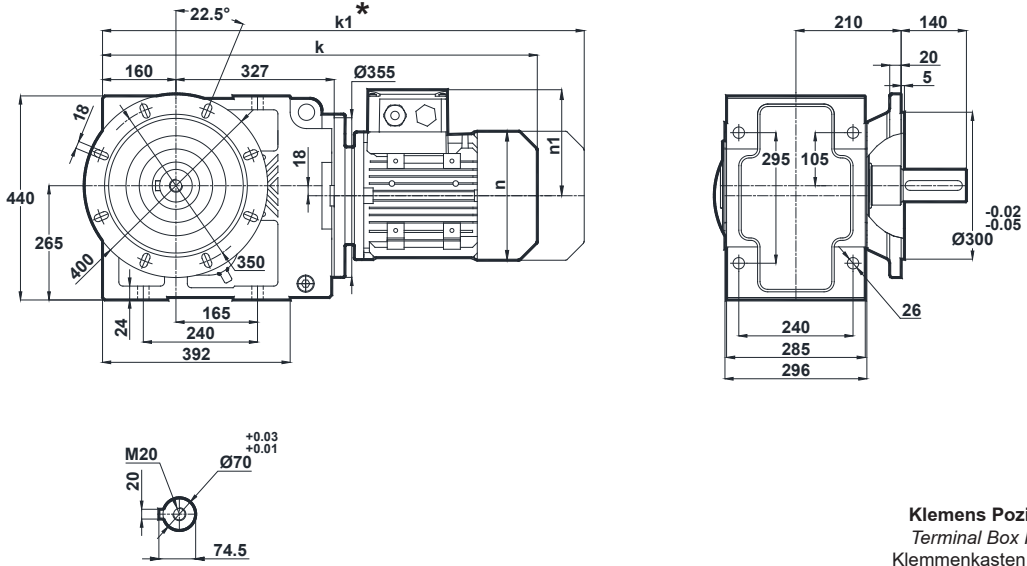

Klemens Pozisyonları  
Terminal Box Positions  
Klemmenkasten Positionen

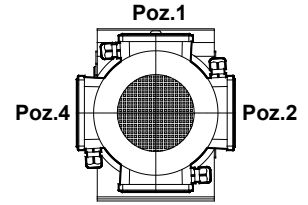

100-112-132-160-180-200-225  
Tip / Type / Typ

	100L	112M	132S	132M	160M	160L	180M	180L	200L	225S	225M
k	797	821	908	908	1004	1004	1075	1075	1117	1143	1168
k1	916.5	925.5	1038	1038	1184	1184	1245.5	1245.5	1303.5	1308	1333
n	193	215	257	257	315	315	347	347	390	434	434
n1	147	158	179	179	219	219	234	234	275	285	285

## KR673.03

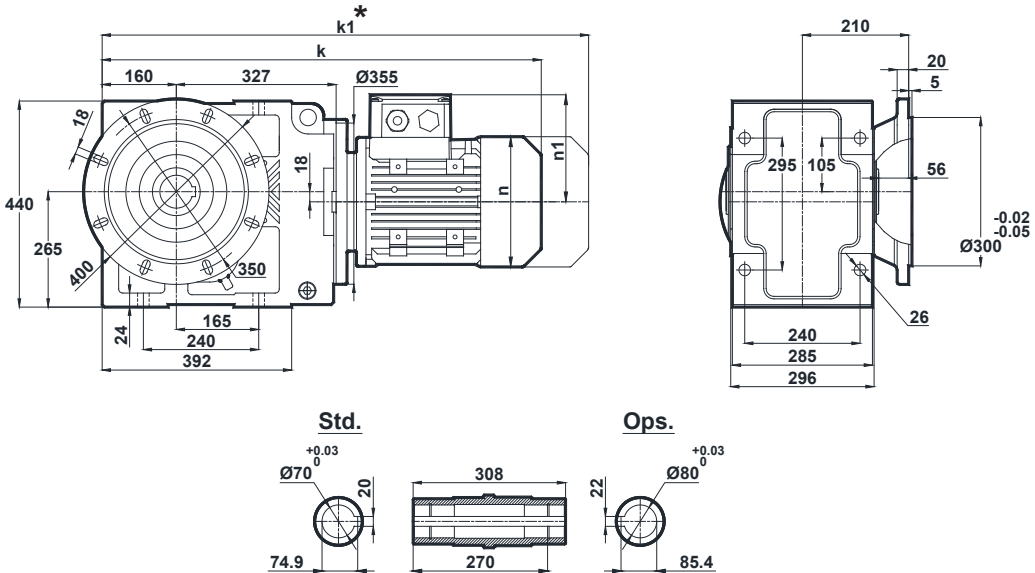

\* "k1" Ölçüsü frenli redüktörlere aittir.  
Dimension "k1" is for motors with brake.  
Maße "k1" ist für Bremsenmotoren.

	100L	112M	132S	132M	160M	160L	180M	180L	200L	225S	225M
k	797	821	908	908	1004	1004	1075	1075	1117	1143	1168
k1	916.5	925.5	1038	1038	1184	1184	1245.5	1245.5	1303.5	1308	1333
n	193	215	257	257	315	315	347	347	390	434	434
n1	147	158	179	179	219	219	234	234	275	285	285

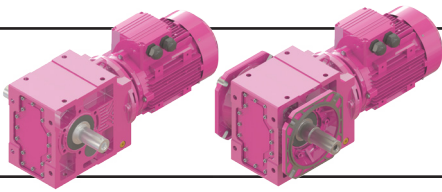

# Ölçü Sayfaları

## Dimension Pages

### Abmessungsseiten

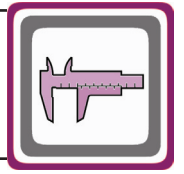

-Mil ucu çektirme deliği DIN 332 sayfa 2 / Tapped center hole to DIN 332, sheet 2 / Zentrierung mit Gewinde DIN 332, Blatt 2

#### KR673.04

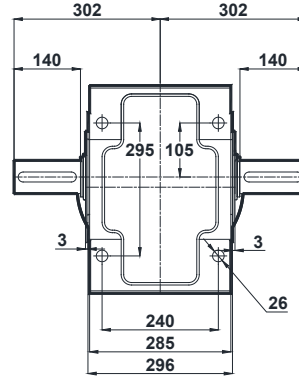
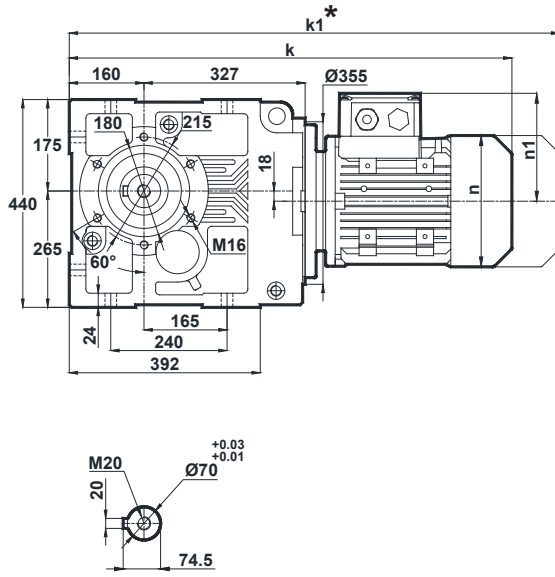

**Klemens Pozisyonları**  
Terminal Box Positions  
Klemmenkasten Positionen

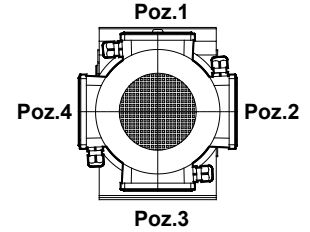

100-112-132-160-180-200-225  
Tip / Type / Typ

	100L	112M	132S	132M	160M	160L	180M	180L	200L	225S	225M
<b>k</b>	797	821	908	908	1004	1004	1075	1075	1117	1143	1168
<b>k1</b>	916.5	925.5	1038	1038	1184	1184	1245.5	1245.5	1303.5	1308	1333
<b>n</b>	193	215	257	257	315	315	347	347	390	434	434
<b>n1</b>	147	158	179	179	219	219	234	234	275	285	285

#### KR673.05

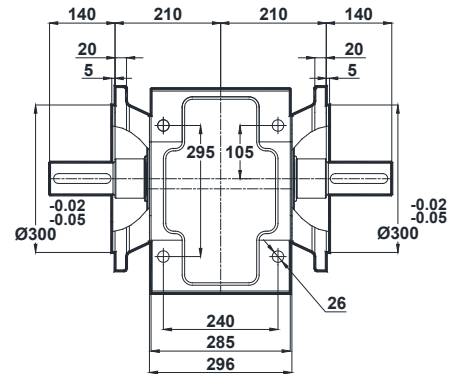
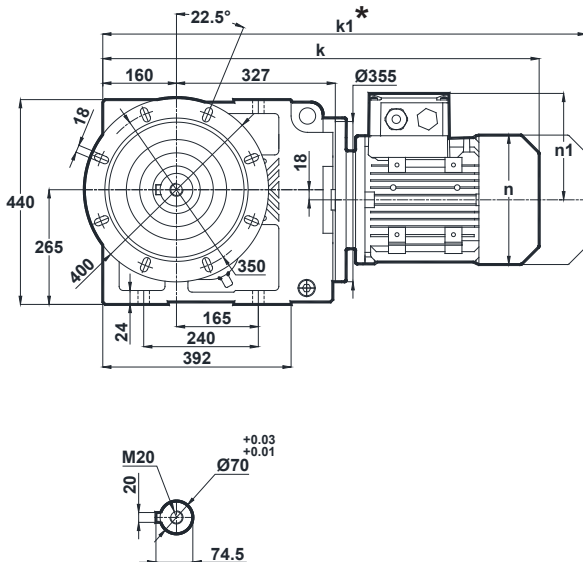

	100L	112M	132S	132M	160M	160L	180M	180L	200L	225S	225M
<b>k</b>	797	821	908	908	1004	1004	1075	1075	1117	1143	1168
<b>k1</b>	916.5	925.5	1038	1038	1184	1184	1245.5	1245.5	1303.5	1308	1333
<b>n</b>	193	215	257	257	315	315	347	347	390	434	434
<b>n1</b>	147	158	179	179	219	219	234	234	275	285	285

\* "k1" Ölçüsü frenli redüktörlere aittir.  
Dimension "k1" is for motors with brake.  
Maße "k1" ist für Bremsenmotoren.



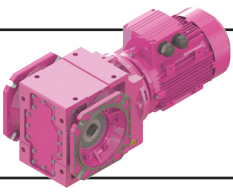

# Ölçü Sayfaları Dimension Pages Abmessungenseiten

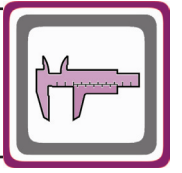

-Mil ucu çektirme deliği DIN 332 sayfa 2 / Tapped center hole to DIN 332, sheet 2 / Zentrierung mit Gewinde DIN 332, Blatt 2

KR673.08

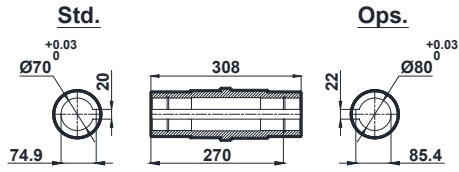
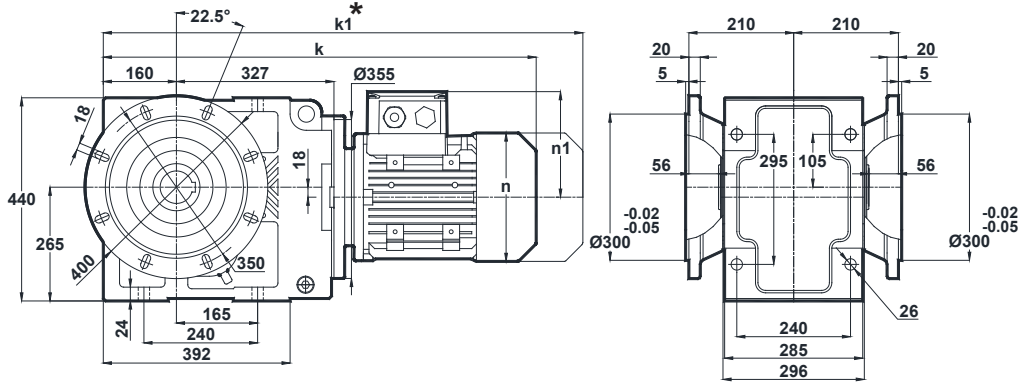

Klemens Pozisyonları  
Terminal Box Positions  
Klemmenkasten Positionen

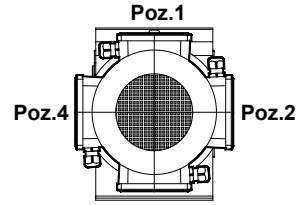

100-112-132-160-180-200-225  
Tip / Type / Typ

	100L	112M	132S	132M	160M	160L	180M	180L	200L	225S	225M
k	797	821	908	908	1004	1004	1075	1075	1117	1143	1168
k1	916.5	925.5	1038	1038	1184	1184	1245.5	1245.5	1303.5	1308	1333
n	193	215	257	257	315	315	347	347	390	434	434
n1	147	158	179	179	219	219	234	234	275	285	285

\* "k1" Ölçüsü frenli redüktörlere aittir.  
Dimension "k1" is for motors with brake.  
Maße "k1" ist für Bremsenmotoren.

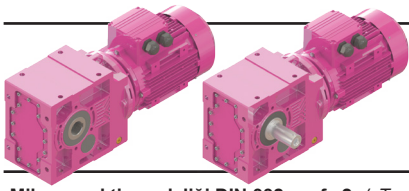

# Ölçü Sayfaları

## Dimension Pages

### Abmessungsseiten

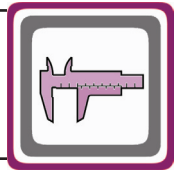

-Mil ucu çektirme deliği DIN 332 sayfa 2 / Tapped center hole to DIN 332, sheet 2 / Zentrierung mit Gewinde DIN 332, Blatt 2

#### KR674.00

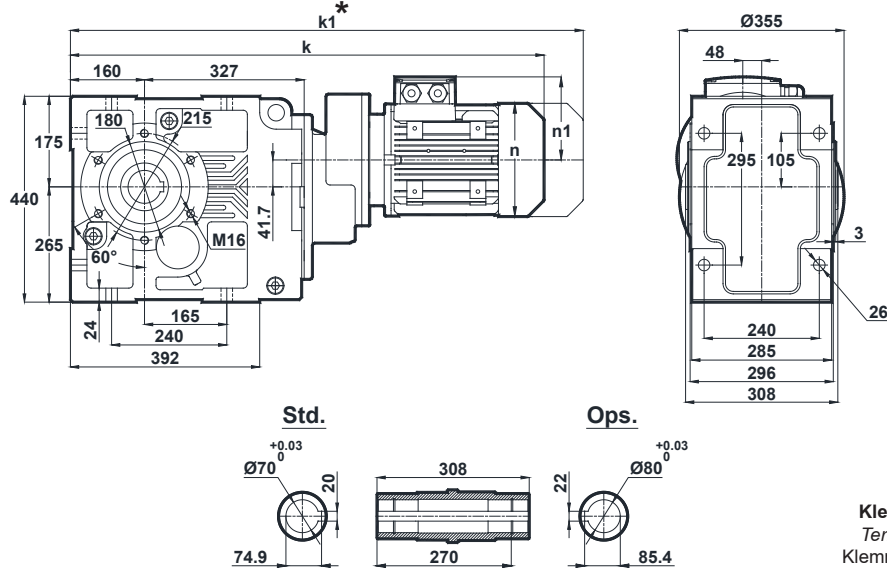

**Klemens Pozisyonları**  
Terminal Box Positions  
Klemmenkasten Positionen

	80	90S	90L	100L
k	830	869	869	913
k1	923	973.5	973.5	1032.5
n	155	176	176	193
n1	121	132	132	147

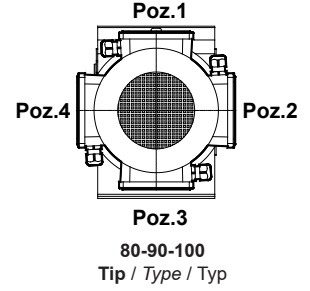

#### KR674.01

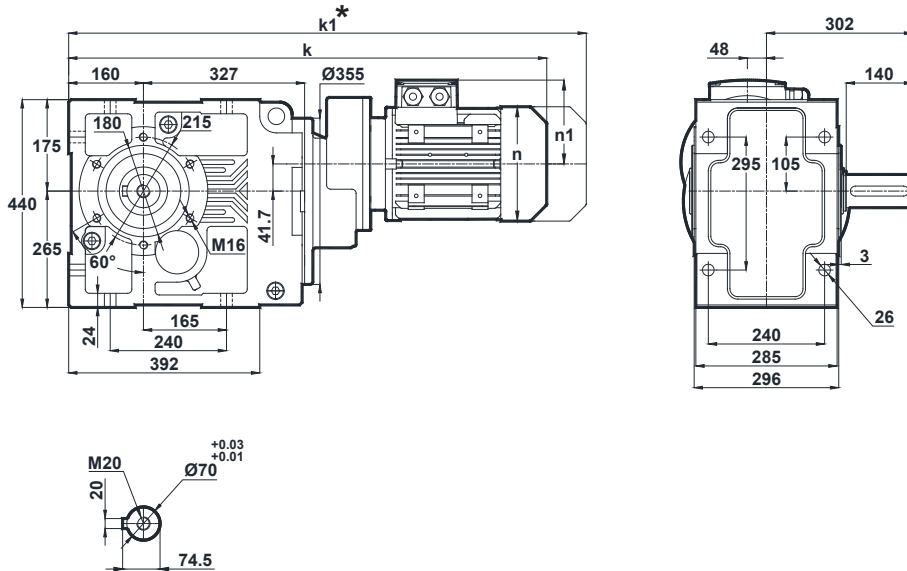

	80	90S	90L	100L
k	830	869	869	913
k1	923	973.5	973.5	1032.5
n	155	176	176	193
n1	121	132	132	147

\* "k1" Ölçüsü frenli redüktörlere aittir.  
Dimension "k1" is for motors with brake.  
Maße "k1" ist für Bremsenmotoren.

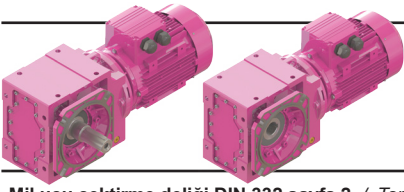

# Ölçü Sayfaları

## Dimension Pages

### Abmessungsseiten

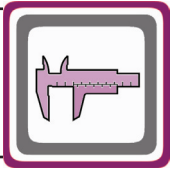

-Mil ucu çektirme deliği DIN 332 sayfa 2 / Tapped center hole to DIN 332, sheet 2 / Zentrierung mit Gewinde DIN 332, Blatt 2

#### KR674.02

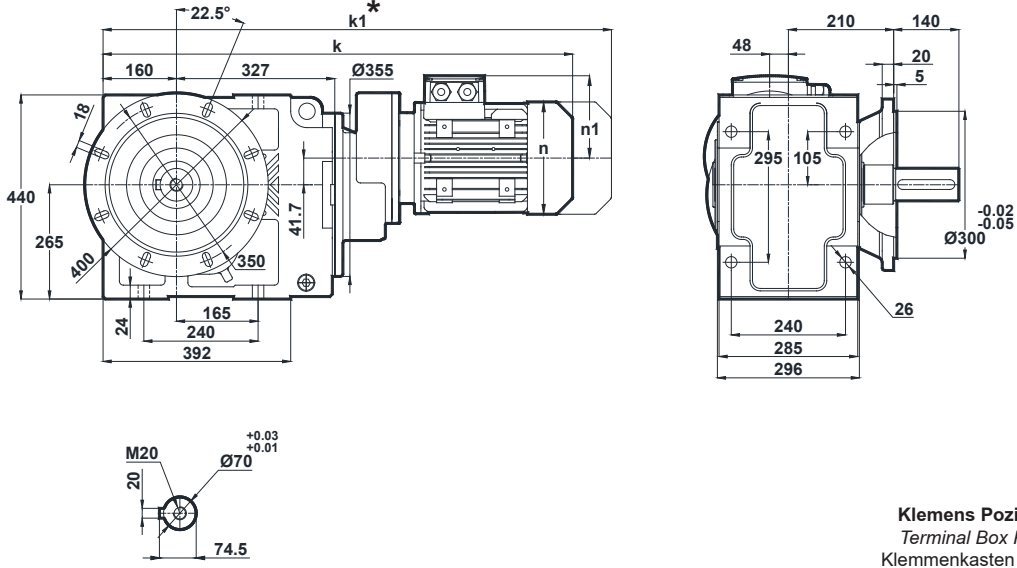

Klemens Pozisyonları  
Terminal Box Positions  
Klemmenkasten Positionen

	80	90S	90L	100L
k	830	869	869	913
k1	923	973.5	973.5	1032.5
n	155	176	176	193
n1	121	132	132	147

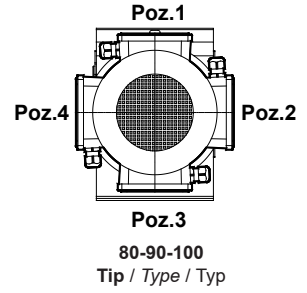

#### KR674.03

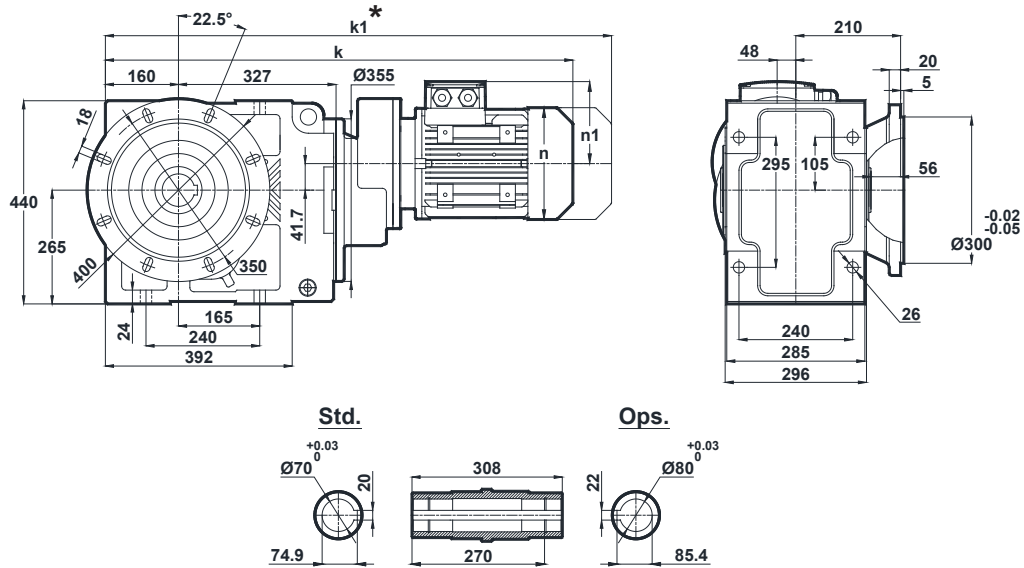

	80	90S	90L	100L
k	830	869	869	913
k1	923	973.5	973.5	1032.5
n	155	176	176	193
n1	121	132	132	147

\* "k1" Ölçüsü frenli redüktörlere aittir.  
Dimension "k1" is for motors with brake.  
Maße "k1" ist für Bremsenmotoren.

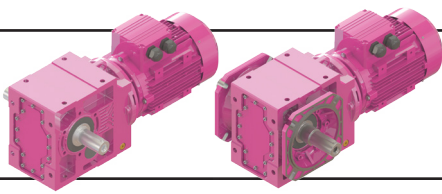

# Ölçü Sayfaları

## Dimension Pages

### Abmessungsseiten

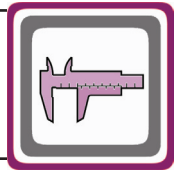

-Mil ucu çektirme deliği DIN 332 sayfa 2 / Tapped center hole to DIN 332, sheet 2 / Zentrierung mit Gewinde DIN 332, Blatt 2

#### KR674.04

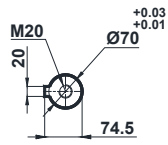
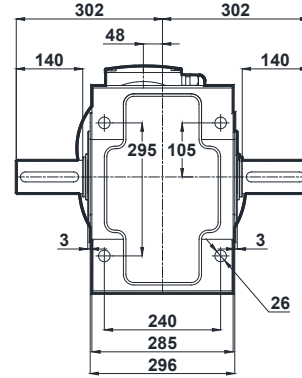
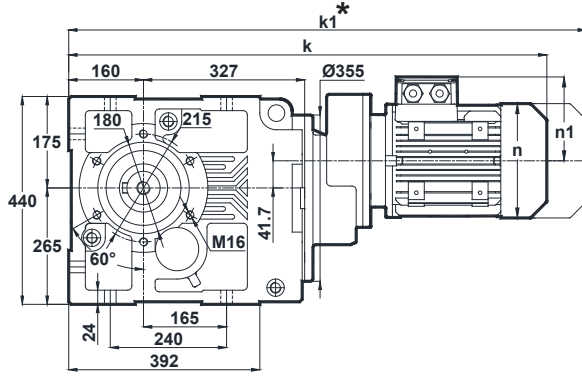

**Klemens Pozisyonları**  
Terminal Box Positions  
Klemmenkasten Positionen

	80	90S	90L	100L
k	830	869	869	913
k1	923	973.5	973.5	1032.5
n	155	176	176	193
n1	121	132	132	147

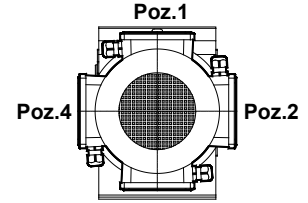

**Poz.3**  
80-90-100  
Tip / Type / Typ

#### KR674.05

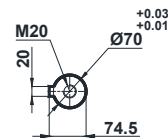
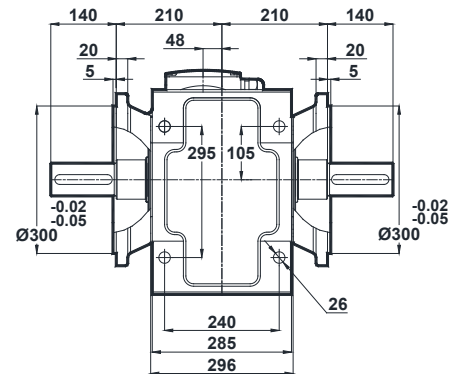
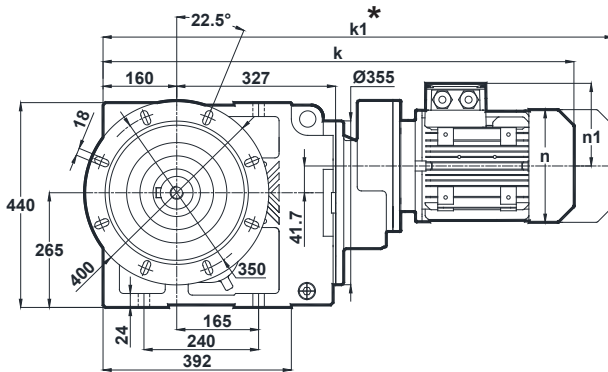

	80	90S	90L	100L
k	830	869	869	913
k1	923	973.5	973.5	1032.5
n	155	176	176	193
n1	121	132	132	147

\* "k1" Ölçüsü frenli redüktörlere aittir.  
Dimension "k1" is for motors with brake.  
Maße "k1" ist für Bremsenmotoren.

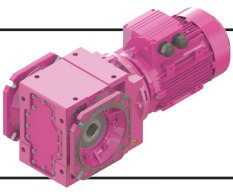

# Ölçü Sayfaları Dimension Pages Abmessungsseiten

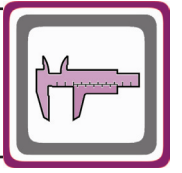

-Mil ucu çektirme deliği DIN 332 sayfa 2 / Tapped center hole to DIN 332, sheet 2 / Zentrierung mit Gewinde DIN 332, Blatt 2

KR674.08

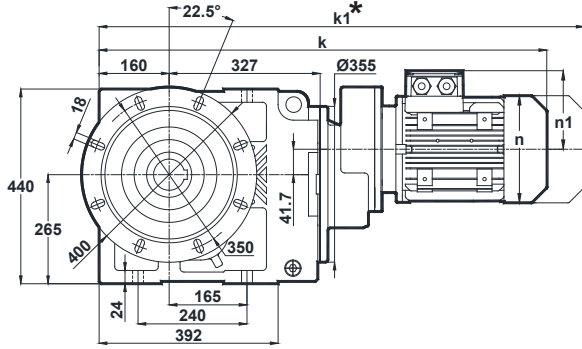

Std.

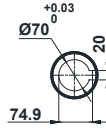

Ops.

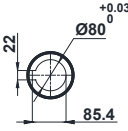

Klemens Pozisyonları  
Terminal Box Positions  
Klemmenkasten Positionen

	80	90S	90L	100L
k	830	869	869	913
k1	923	973.5	973.5	1032.5
n	155	176	176	193
n1	121	132	132	147

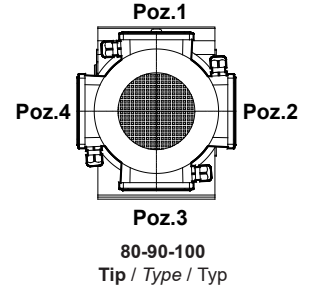

\* "k1" Ölçüsü frenli redüktörlere aittir.  
Dimension "k1" is for motors with brake.  
Maße "k1" ist für Bremsenmotoren.

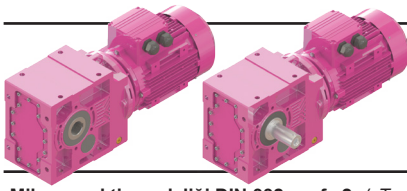

# Ölçü Sayfaları

## Dimension Pages

### Abmessungsseiten

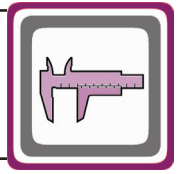

-Mil ucu çekirme deliği DIN 332 sayfa 2 / Tapped center hole to DIN 332, sheet 2 / Zentrierung mit Gewinde DIN 332, Blatt 2

KR675.00  
KR676.00

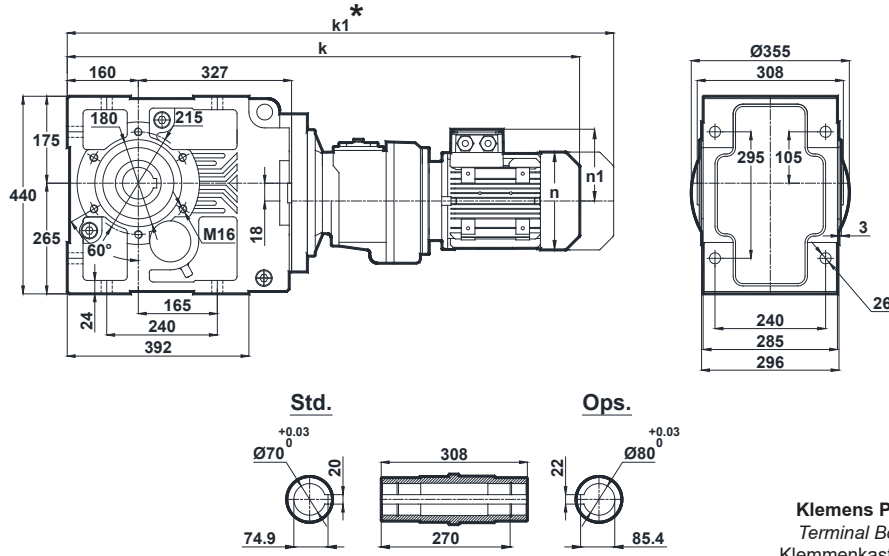

**Klemens Pozisyonları**  
Terminal Box Positions  
Klemmenkasten Positionen

	71	80	90S
k	942	976	1015
k1	1033	1069	1119.5
n	137	155	176
n1	112	121	132

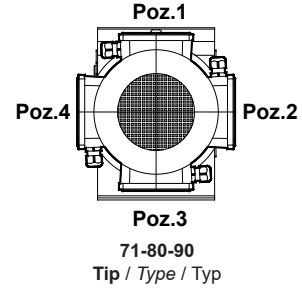

KR675.01  
KR676.01

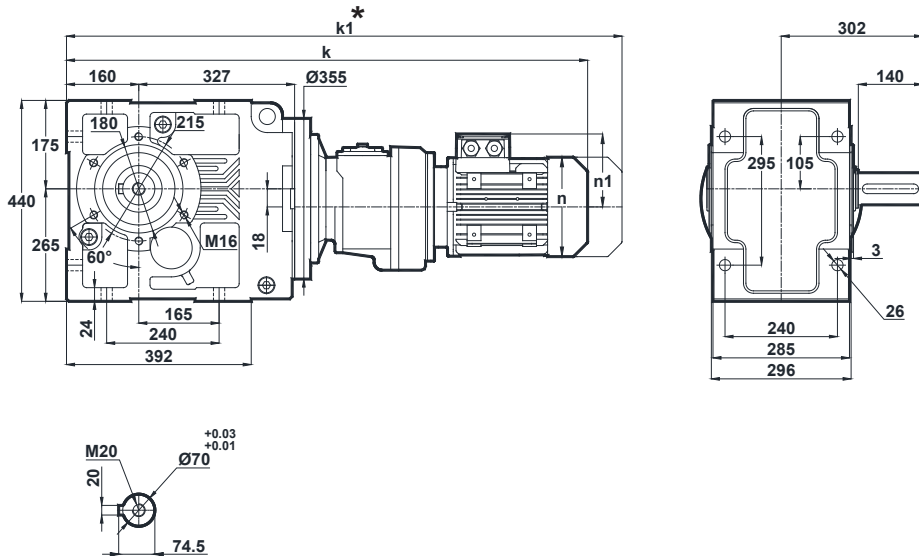

	71	80	90S
k	942	976	1015
k1	1033	1069	1119.5
n	137	155	176
n1	112	121	132

\* "k1" Ölçüsü frenli redüktörlere aittir.  
Dimension "k1" is for motors with brake.  
Maße "k1" ist für Bremsenmotoren.

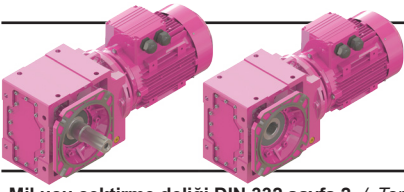

# Ölçü Sayfaları

## Dimension Pages

### Abmessungsseiten

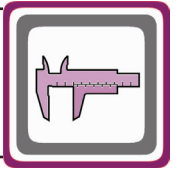

-Mil ucu çektirme deliği DIN 332 sayfa 2 / Tapped center hole to DIN 332, sheet 2 / Zentrierung mit Gewinde DIN 332, Blatt 2

KR675.02  
KR676.02

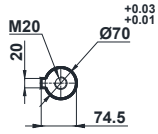
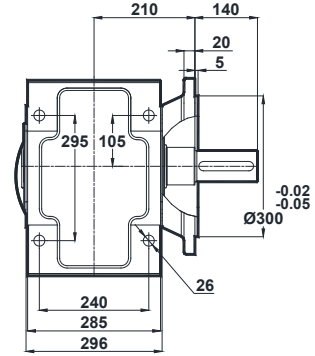
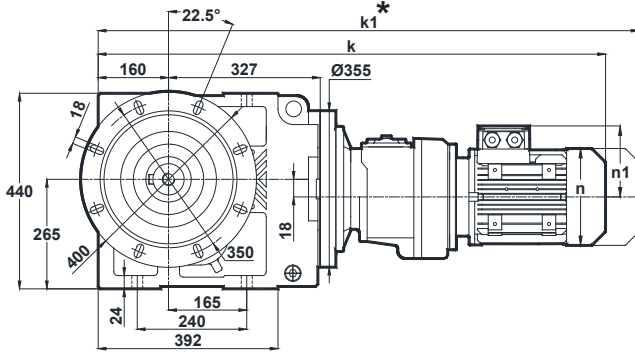

Klemens Pozisyonları  
Terminal Box Positions  
Klemmenkasten Positionen

	71	80	90S
k	942	976	1015
k1	1033	1069	1119.5
n	137	155	176
n1	112	121	132

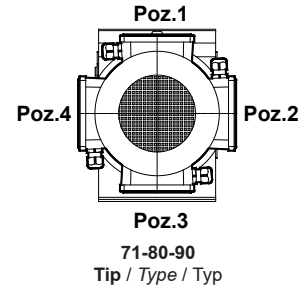

KR675.03  
KR676.03

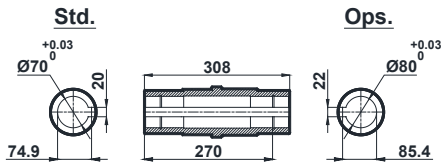
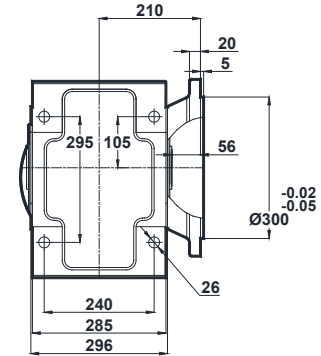
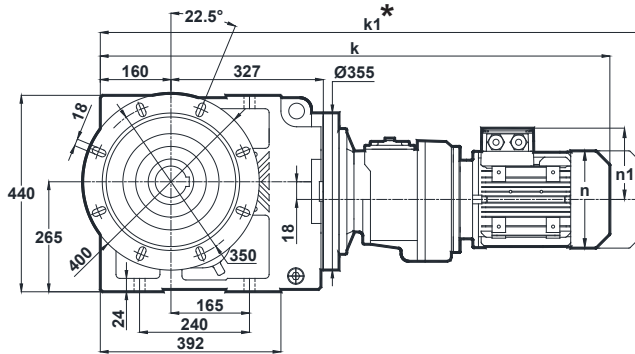

	71	80	90S
k	942	976	1015
k1	1033	1069	1119.5
n	137	155	176
n1	112	121	132

\* "k1" Ölçüsü frenli redüktörlere aittir.  
Dimension "k1" is for motors with brake.  
Maße "k1" ist für Bremsenmotoren.

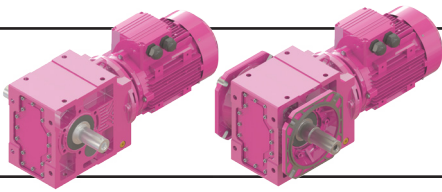

# Ölçü Sayfaları

## Dimension Pages

### Abmessungsseiten

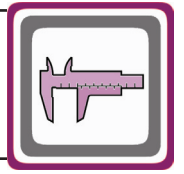

-Mil ucu çekirme deliği DIN 332 sayfa 2 / Tapped center hole to DIN 332, sheet 2 / Zentrierung mit Gewinde DIN 332, Blatt 2

KR675.04  
KR676.04

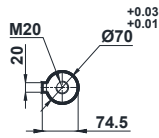
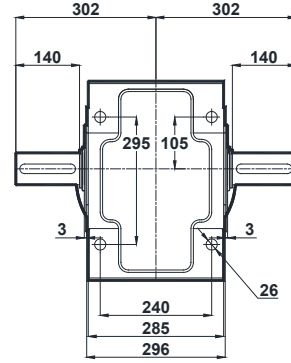
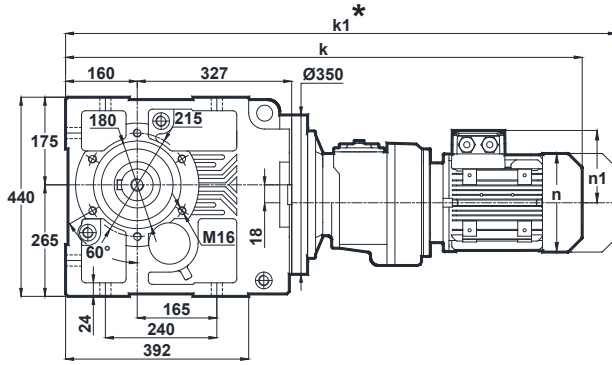

**Klemens Pozisyonları**  
Terminal Box Positions  
Klemmenkasten Positionen

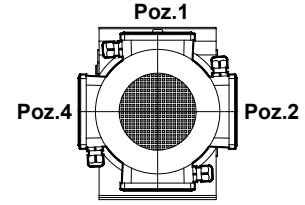

**Poz.3**

71-80-90  
Tip / Type / Typ

	71	80	90S
k	942	976	1015
k1	1033	1069	1119.5
n	137	155	176
n1	112	121	132

KR675.05  
KR676.05

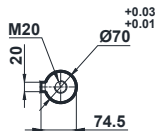
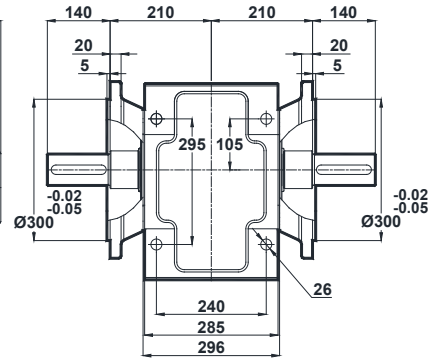
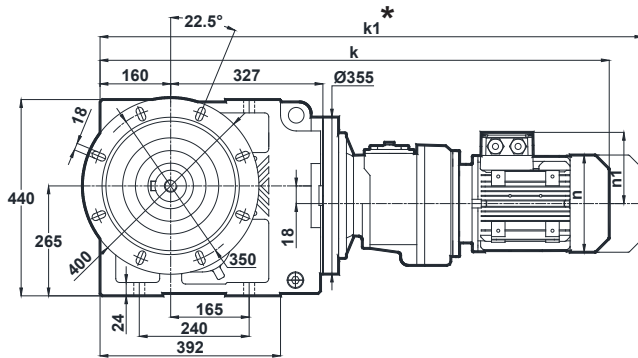

	71	80	90S
k	942	976	1015
k1	1033	1069	1119.5
n	137	155	176
n1	112	121	132

\* "k1" Ölçüsü frenli redüktörlere aittir.  
Dimension "k1" is for motors with brake.  
Maße "k1" ist für Bremsenmotoren.



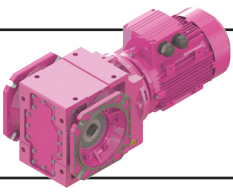

# Ölçü Sayfaları Dimension Pages Abmessungenseiten

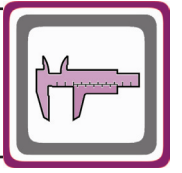

-Mil ucu çektirme deliği DIN 332 sayfa 2 / Tapped center hole to DIN 332, sheet 2 / Zentrierung mit Gewinde DIN 332, Blatt 2

KR675.08  
KR676.08

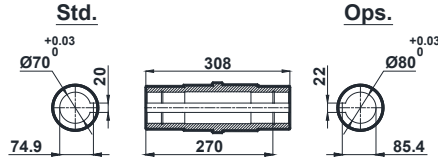
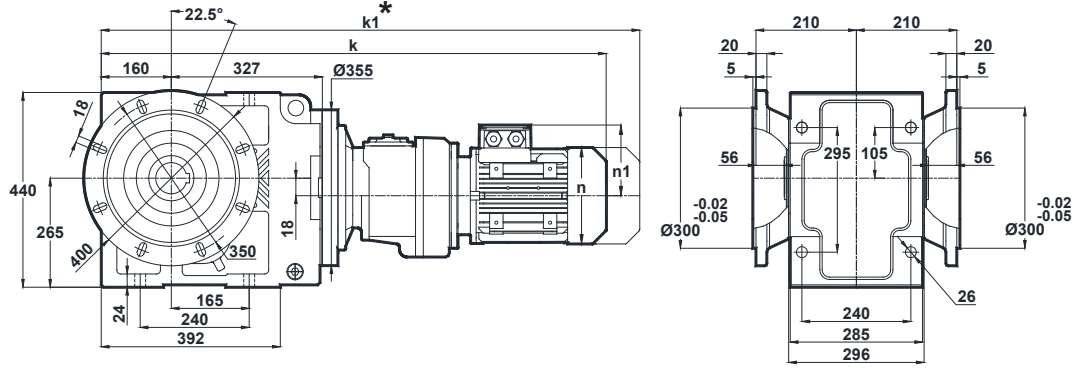

Klemens Pozisyonları  
Terminal Box Positions  
Klemmenkasten Positionen

	71	80	90S
k	942	976	1015
k1	1033	1069	1119.5
n	137	155	176
n1	112	121	132

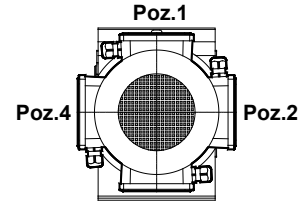

Poz.3  
71-80-90  
Tip / Type / Typ

\* " k1 " Ölçüsü frenli redüktörlere aittir.  
Dimension " k1 " is for motors with brake.  
Maße " k1 " ist für Bremsenmotoren.

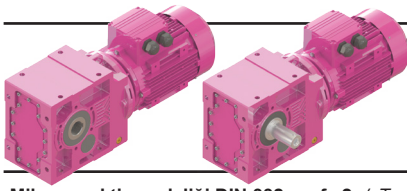

# Ölçü Sayfaları

## Dimension Pages

### Abmessungsseiten

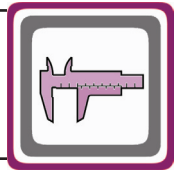

-Mil ucu çektirme deliği DIN 332 sayfa 2 / Tapped center hole to DIN 332, sheet 2 / Zentrierung mit Gewinde DIN 332, Blatt 2

#### KR773.00

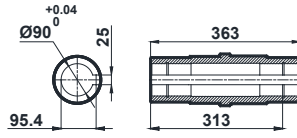
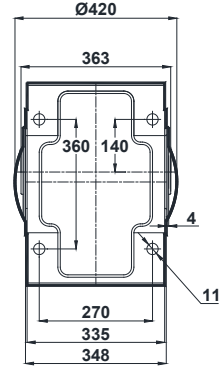
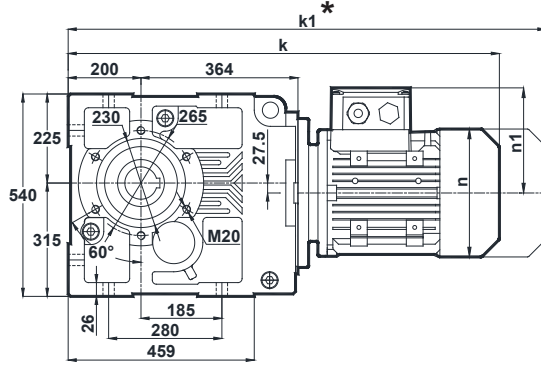

**Klemens Pozisyonları**  
Terminal Box Positions  
Klemmenkasten Positionen

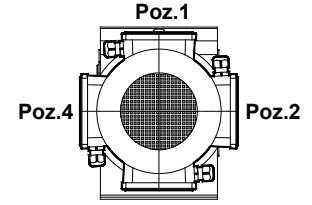

**Poz.3**  
132-160-180-200-225-250  
Tip / Type / Typ

	132S	132M	160M	160L	180M	180L	200L	225S	225M	250M
<b>k</b>	981	981	1077	1077	1148	1148	1190	1217	1242	1346
<b>k1</b>	1111	1111	1257	1257	1318.5	1318.5	1376.5	1382	1407	1516.5
<b>n</b>	257	257	315	315	347	347	390	434	434	480
<b>n1</b>	179	179	219	219	234	234	275	285	285	322

#### KR773.01

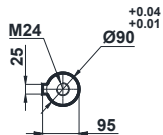
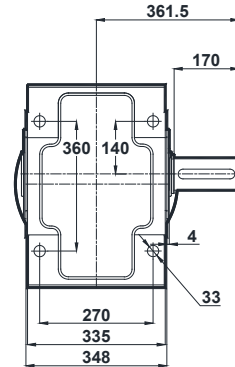
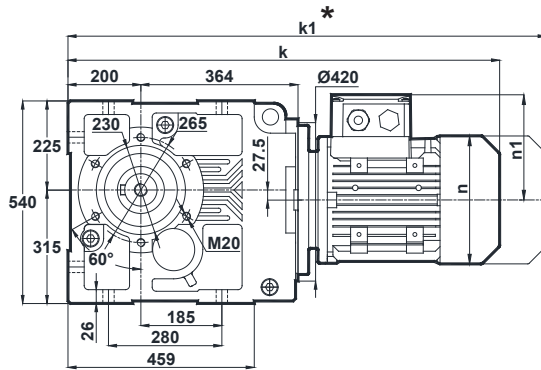

	132S	132M	160M	160L	180M	180L	200L	225S	225M	250M
<b>k</b>	981	981	1077	1077	1148	1148	1190	1217	1242	1346
<b>k1</b>	1111	1111	1257	1257	1318.5	1318.5	1376.5	1382	1407	1516.5
<b>n</b>	257	257	315	315	347	347	390	434	434	480
<b>n1</b>	179	179	219	219	234	234	275	285	285	322

\* "k1" Ölçüsü frenli redüktörlere aittir.  
Dimension "k1" is for motors with brake.  
Maße "k1" ist für Bremsenmotoren.

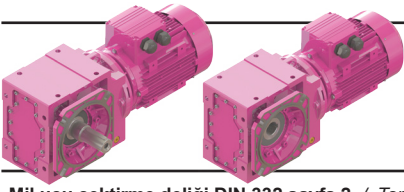

# Ölçü Sayfaları Dimension Pages Abmessungsseiten

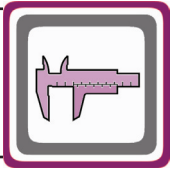

-Mil ucu çektirme deliği DIN 332 sayfa 2 / Tapped center hole to DIN 332, sheet 2 / Zentrierung mit Gewinde DIN 332, Blatt 2

## KR773.02

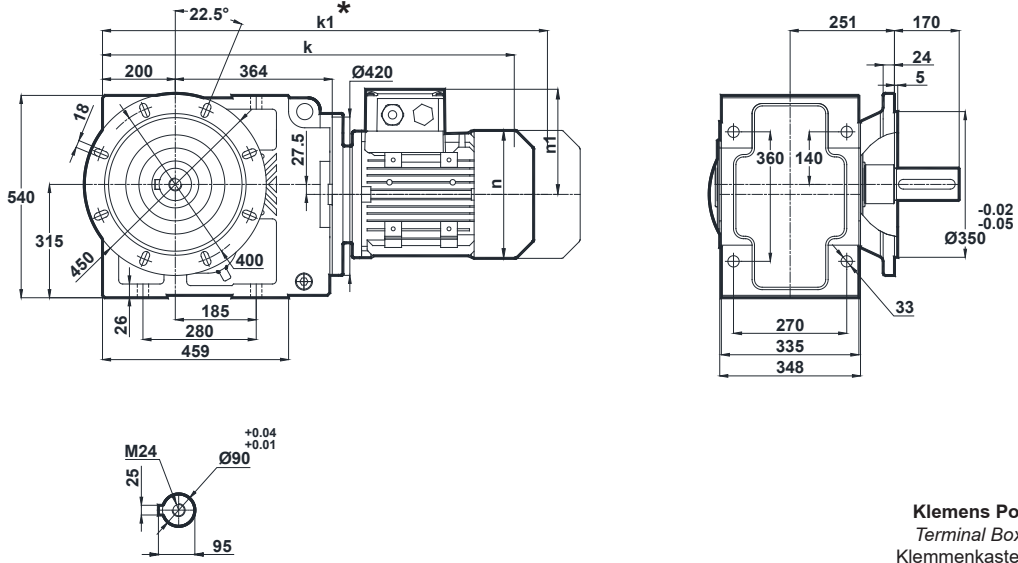

Klemens Pozisyonları  
Terminal Box Positions  
Klemmenkasten Positionen

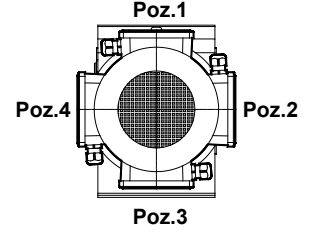

132-160-180-200-225-250  
Tip / Type / Typ

	132S	132M	160M	160L	180M	180L	200L	225S	225M	250M
k	981	981	1077	1077	1148	1148	1190	1217	1242	1346
k1	1111	1111	1257	1257	1318.5	1318.5	1376.5	1382	1407	1516.5
n	257	257	315	315	347	347	390	434	434	480
n1	179	179	219	219	234	234	275	285	285	322

## KR773.03

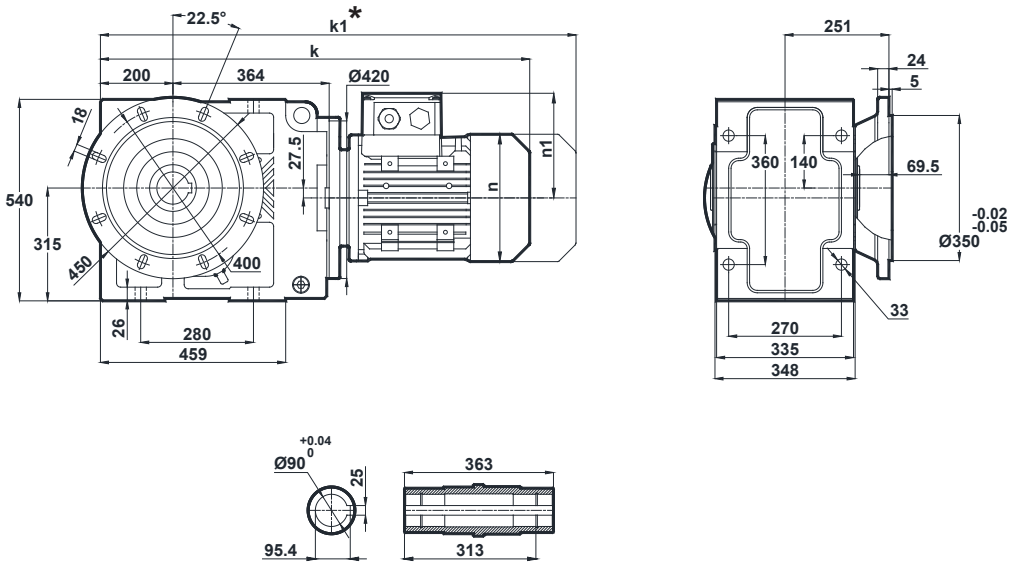

	132S	132M	160M	160L	180M	180L	200L	225S	225M	250M
k	981	981	1077	1077	1148	1148	1190	1217	1242	1346
k1	1111	1111	1257	1257	1318.5	1318.5	1376.5	1382	1407	1516.5
n	257	257	315	315	347	347	390	434	434	480
n1	179	179	219	219	234	234	275	285	285	322

\* "k1" Ölçüsü frenli redüktörlere aittir.  
Dimension "k1" is for motors with brake.  
Maße "k1" ist für Bremsenmotoren.

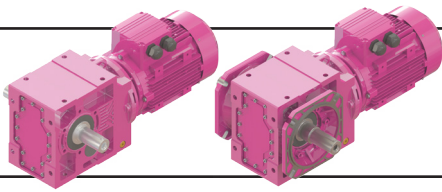

# Ölçü Sayfaları

## Dimension Pages

### Abmessungsseiten

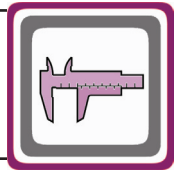

-Mil ucu çektirme deliği DIN 332 sayfa 2 / Tapped center hole to DIN 332, sheet 2 / Zentrierung mit Gewinde DIN 332, Blatt 2

#### KR773.04

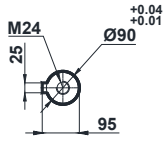
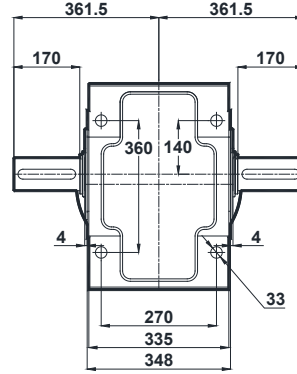
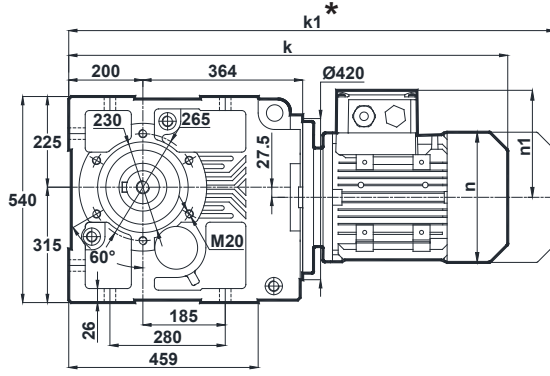

**Klemens Pozisyonları**  
Terminal Box Positions  
Klemmenkasten Positionen

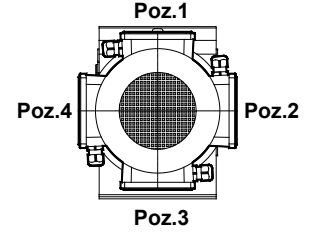

132-160-180-200-225-250  
Tip / Type / Typ

	132S	132M	160M	160L	180M	180L	200L	225S	225M	250M
k	981	981	1077	1077	1148	1148	1190	1217	1242	1346
k1	1111	1111	1257	1257	1318.5	1318.5	1376.5	1382	1407	1516.5
n	257	257	315	315	347	347	390	434	434	480
n1	179	179	219	219	234	234	275	285	285	322

#### KR773.05

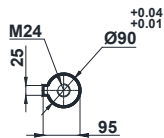
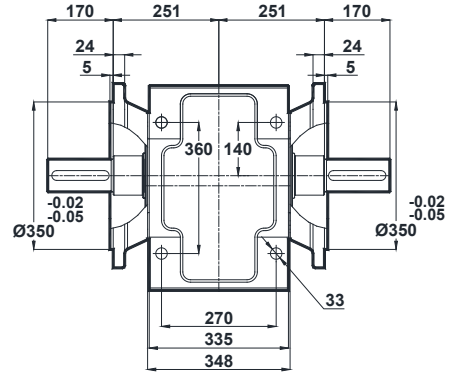
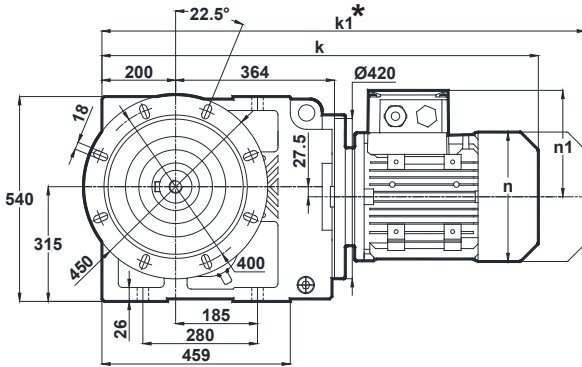

	132S	132M	160M	160L	180M	180L	200L	225S	225M	250M
k	981	981	1077	1077	1148	1148	1190	1217	1242	1346
k1	1111	1111	1257	1257	1318.5	1318.5	1376.5	1382	1407	1516.5
n	257	257	315	315	347	347	390	434	434	480
n1	179	179	219	219	234	234	275	285	285	322

\* "k1" Ölçüsü frenli redüktörlere aittir.  
Dimension "k1" is for motors with brake.  
Maße "k1" ist für Bremsenmotoren.

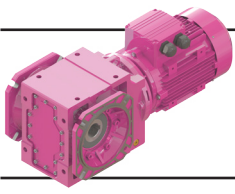

# Ölçü Sayfaları Dimension Pages Abmessungsseiten

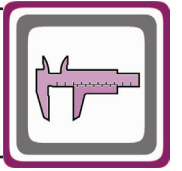

-Mil ucu çektirme deliği DIN 332 sayfa 2 / Tapped center hole to DIN 332, sheet 2 / Zentrierung mit Gewinde DIN 332, Blatt 2

KR773.08

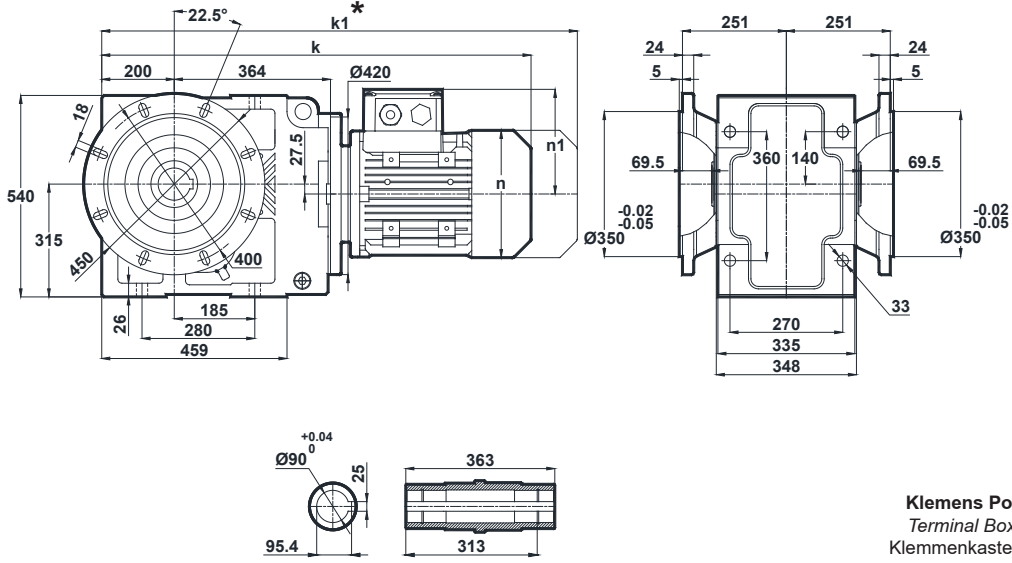

Klemens Pozisyonları  
Terminal Box Positions  
Klemmenkasten Positionen

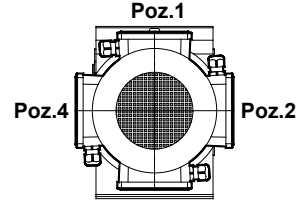

Poz.1  
Poz.2  
Poz.3  
Poz.4  
132-160-180-200-225-250  
Tip / Type / Typ

	132S	132M	160M	160L	180M	180L	200L	225S	225M	250M
k	981	981	1077	1077	1148	1148	1190	1217	1242	1346
k1	1111	1111	1257	1257	1318.5	1318.5	1376.5	1382	1407	1516.5
n	257	257	315	315	347	347	390	434	434	480
n1	179	179	219	219	234	234	275	285	285	322

\* "k1" Ölçüsü frenli redüktörlere aittir.  
Dimension "k1" is for motors with brake.  
Maße "k1" ist für Bremsenmotoren.

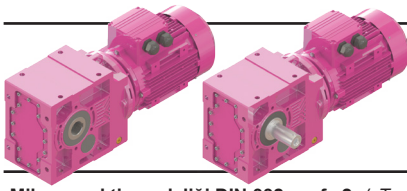

# Ölçü Sayfaları

## Dimension Pages

### Abmessungsseiten

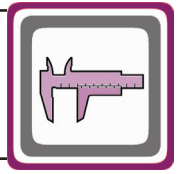

-Mil ucu çektirme deliği DIN 332 sayfa 2 / Tapped center hole to DIN 332, sheet 2 / Zentrierung mit Gewinde DIN 332, Blatt 2

#### KR774.00

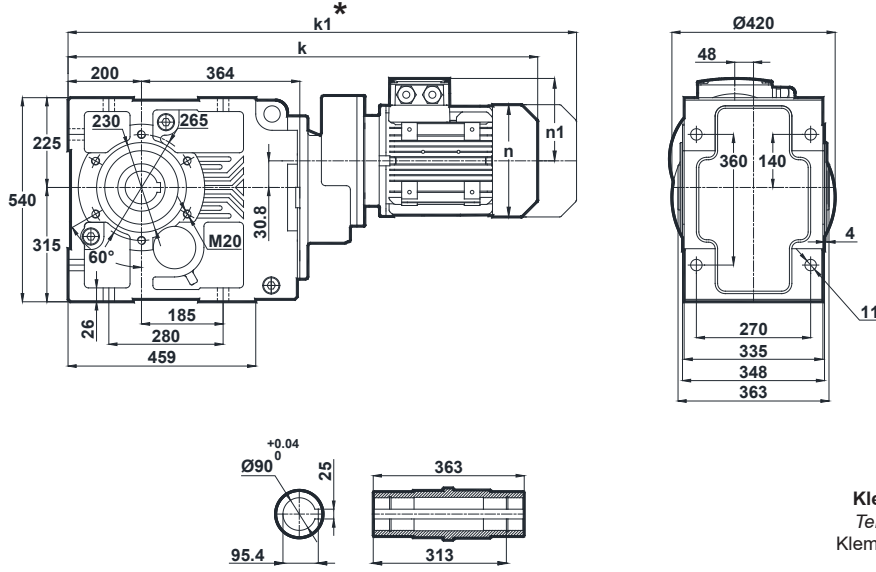

	90S	90L	100L	112M	132S	132M
k	946	946	990	1015	1100	1100
k1	1050.5	1050.5	1109.5	1119.5	1230	1230
n	176	176	193	215	257	257
n1	132	132	147	158	179	179

**Klemens Pozisyonları**  
Terminal Box Positions  
Klemmenkasten Positionen

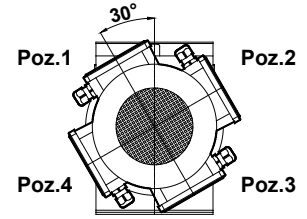

90-100-112-132  
Tip / Type / Typ

#### KR774.01

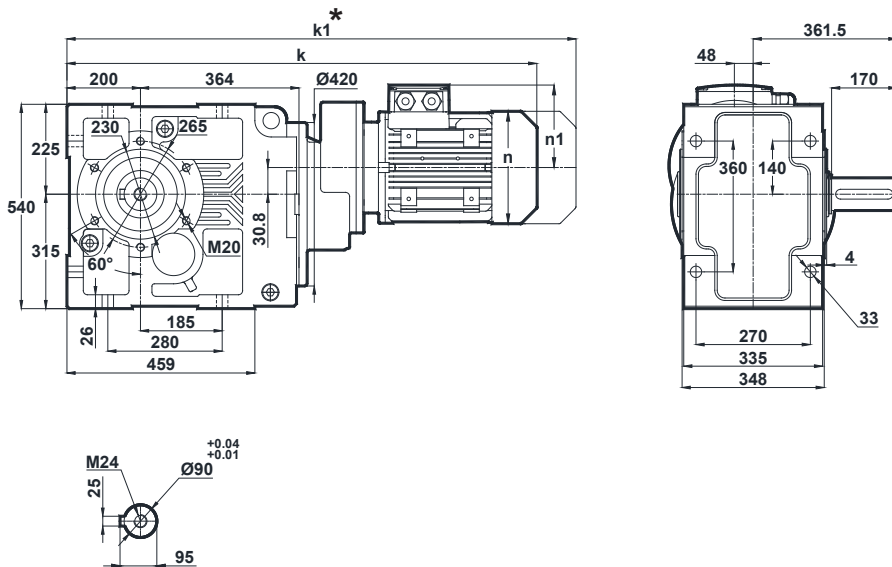

	90S	90L	100L	112M	132S	132M
k	946	946	990	1015	1100	1100
k1	1050.5	1050.5	1109.5	1119.5	1230	1230
n	176	176	193	215	257	257
n1	132	132	147	158	179	179

\* "k1" Ölçüsü frenli redüktörlere aittir.  
Dimension "k1" is for motors with brake.  
Maße "k1" ist für Bremsenmotoren.

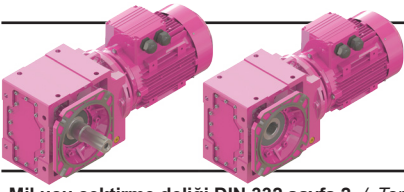

# Ölçü Sayfaları Dimension Pages Abmessungsseiten

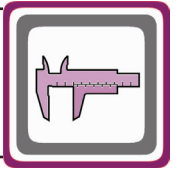

-Mil ucu çektirme deliği DIN 332 sayfa 2 / Tapped center hole to DIN 332, sheet 2 / Zentrierung mit Gewinde DIN 332, Blatt 2

## KR774.02

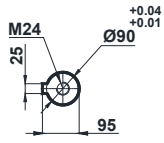
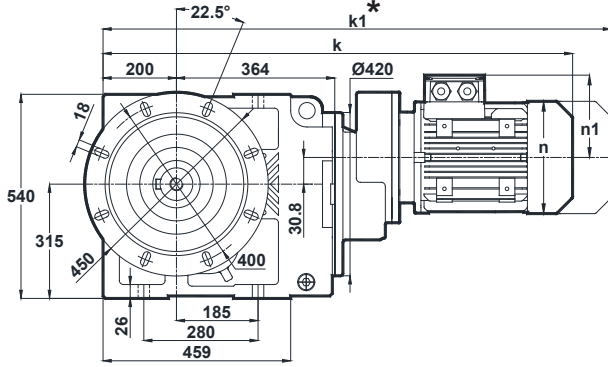

Klemens Pozisyonları  
Terminal Box Positions  
Klemmenkasten Positionen

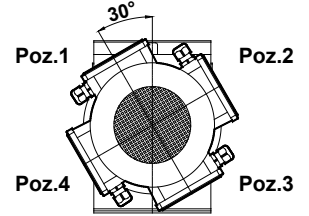

90-100-112-132  
Tip / Type / Typ

	90S	90L	100L	112M	132S	132M
k	946	946	990	1015	1100	1100
k1	1050.5	1050.5	1109.5	1119.5	1230	1230
n	176	176	193	215	257	257
n1	132	132	147	158	179	179

## KR774.03

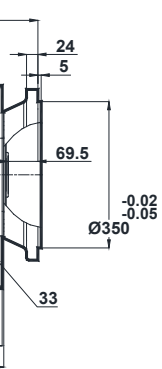
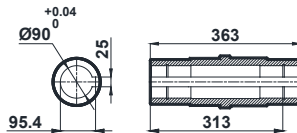
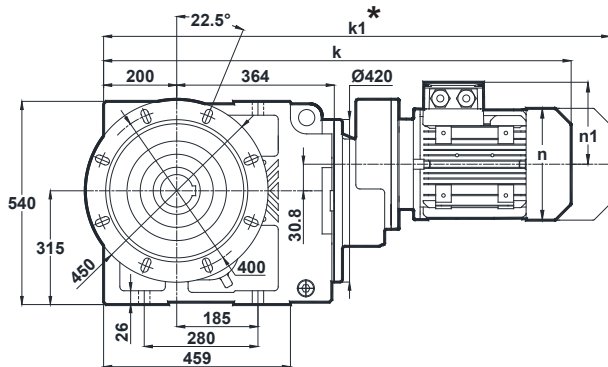

	90S	90L	100L	112M	132S	132M
k	946	946	990	1015	1100	1100
k1	1050.5	1050.5	1109.5	1119.5	1230	1230
n	176	176	193	215	257	257
n1	132	132	147	158	179	179

\* " k1 " Ölçüsü frenli redüktörlere aittir.  
Dimension " k1 " is for motors with brake.  
Maße " k1 " ist für Bremsenmotoren.

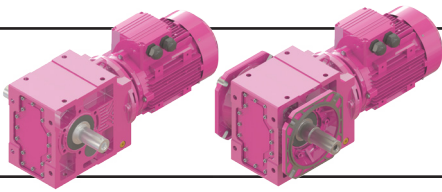

# Ölçü Sayfaları

## Dimension Pages

### Abmessungsseiten

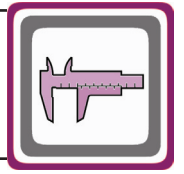

-Mil ucu çekirme deliği DIN 332 sayfa 2 / Tapped center hole to DIN 332, sheet 2 / Zentrierung mit Gewinde DIN 332, Blatt 2

#### KR774.04

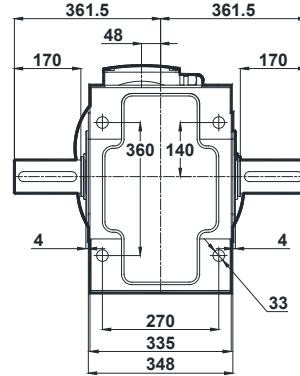
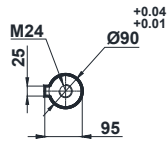
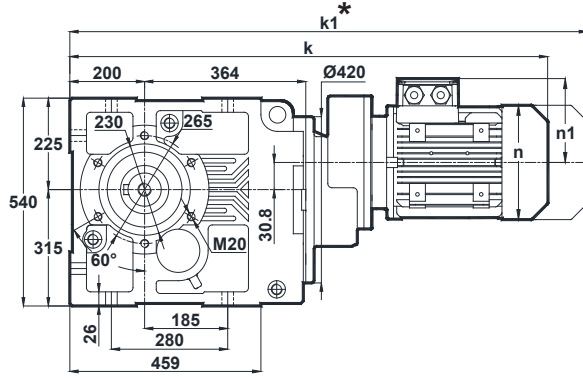

**Klemens Pozisyonları**  
Terminal Box Positions  
Klemmenkasten Positionen

	90S	90L	100L	112M	132S	132M
<b>k</b>	946	946	990	1015	1100	1100
<b>k1</b>	1050.5	1050.5	1109.5	1119.5	1230	1230
<b>n</b>	176	176	193	215	257	257
<b>n1</b>	132	132	147	158	179	179

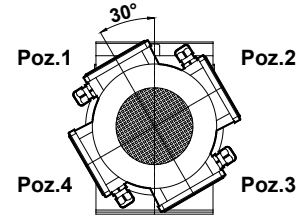

90-100-112-132  
Tip / Type / Typ

#### KR774.05

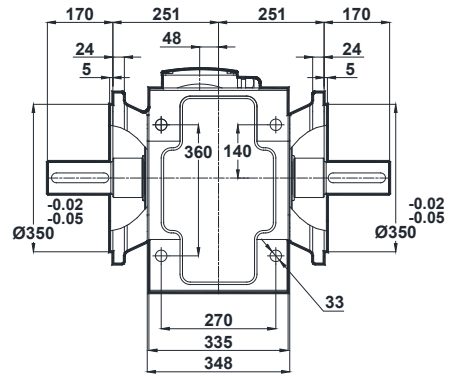
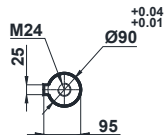
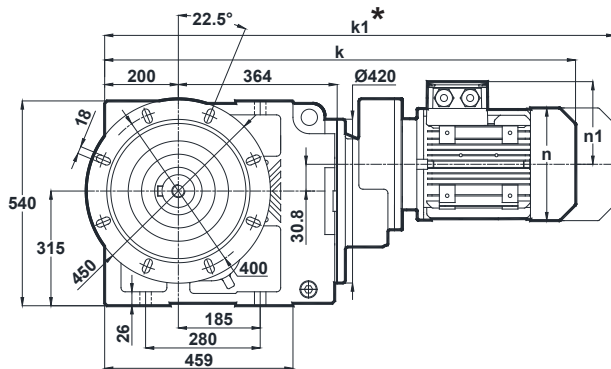

	90S	90L	100L	112M	132S	132M
<b>k</b>	946	946	990	1015	1100	1100
<b>k1</b>	1050.5	1050.5	1109.5	1119.5	1230	1230
<b>n</b>	176	176	193	215	257	257
<b>n1</b>	132	132	147	158	179	179

\* "k1" Ölçüsü frenli redüktörlere aittir.  
Dimension "k1" is for motors with brake.  
Maße "k1" ist für Bremsenmotoren.



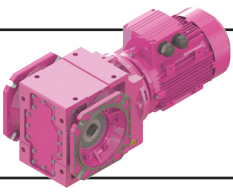

# Ölçü Sayfaları Dimension Pages Abmessungsseiten

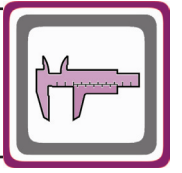

-Mil ucu çektirme deliği DIN 332 sayfa 2 / Tapped center hole to DIN 332, sheet 2 / Zentrierung mit Gewinde DIN 332, Blatt 2

KR774.08

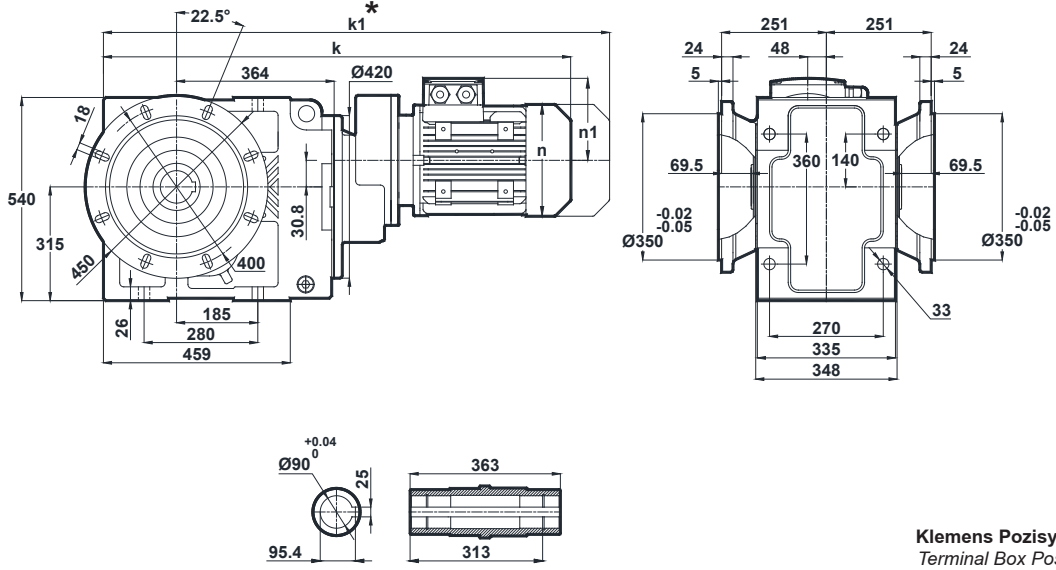

	90S	90L	100L	112M	132S	132M
k	946	946	990	1015	1100	1100
k1	1050.5	1050.5	1109.5	1119.5	1230	1230
n	176	176	193	215	257	257
n1	132	132	147	158	179	179

Klemens Pozisyonları  
Terminal Box Positions  
Klemmenkasten Positionen

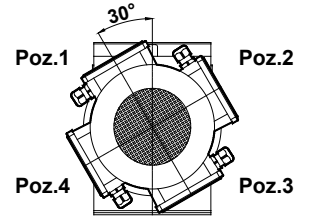

90-100-112-132  
Tip / Type / Typ

\* "k1" Ölçüsü frenli redüktörlere aittir.  
Dimension "k1" is for motors with brake.  
Maße "k1" ist für Bremsenmotoren.

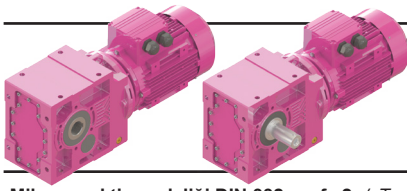

# Ölçü Sayfaları Dimension Pages Abmessungsseiten

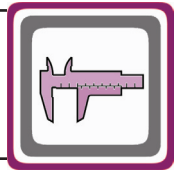

-Mil ucu çektirme deliği DIN 332 sayfa 2 / Tapped center hole to DIN 332, sheet 2 / Zentrierung mit Gewinde DIN 332, Blatt 2

KR775.00  
KR776.00

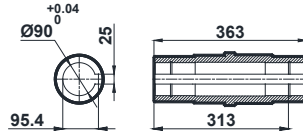
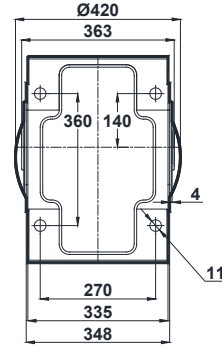
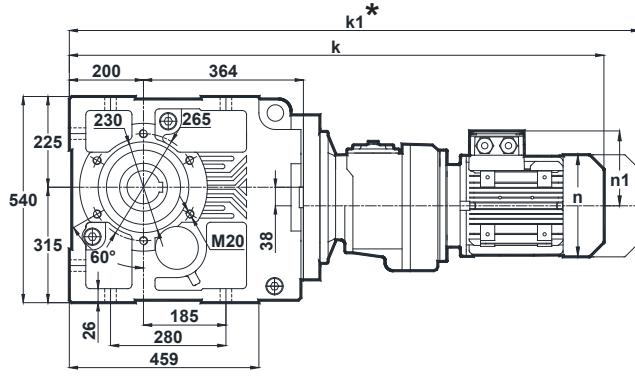

**Klemens Pozisyonları**  
Terminal Box Positions  
Klemmenkasten Positionen

	71	80	90S	90L	100L
k	1019	1053	1092	1092	1140
k1	1110	1146	1196.5	1196.5	1259.5
n	137	155	176	176	193
n1	112	121	132	132	147

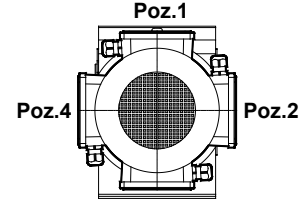

**Poz.3**  
71-80-90-100  
Tip / Type / Typ

KR775.01  
KR776.01

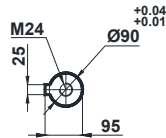
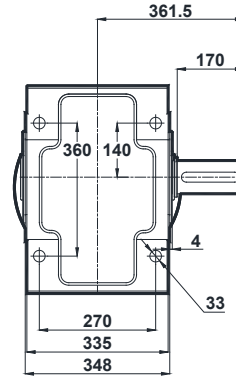
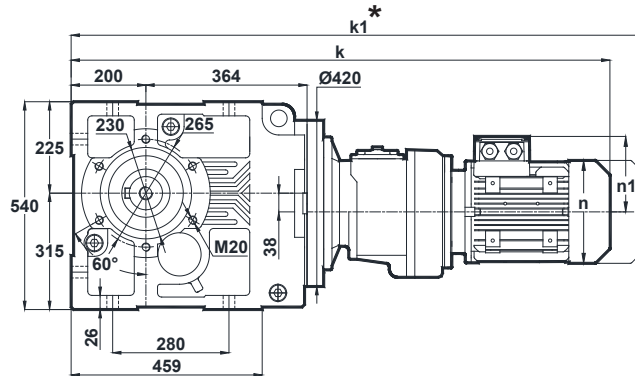

	71	80	90S	90L	100L
k	1019	1053	1092	1092	1140
k1	1110	1146	1196.5	1196.5	1259.5
n	137	155	176	176	193
n1	112	121	132	132	147

\* "k1" Ölçüsü frenli redüktörlere aittir.  
Dimension "k1" is for motors with brake.  
Maße "k1" ist für Bremsenmotoren.

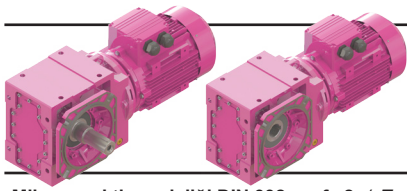

# Ölçü Sayfaları

## Dimension Pages

### Abmessungsseiten

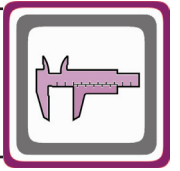

-Mil ucu çektirme deliği DIN 332 sayfa 2 / Tapped center hole to DIN 332, sheet 2 / Zentrierung mit Gewinde DIN 332, Blatt 2

KR775.02  
KR776.02

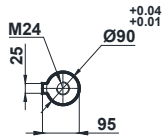
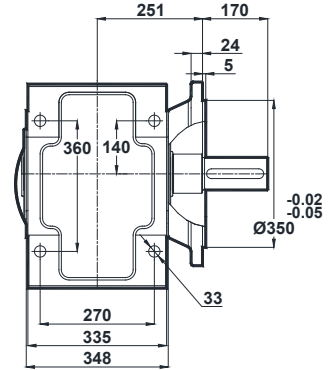
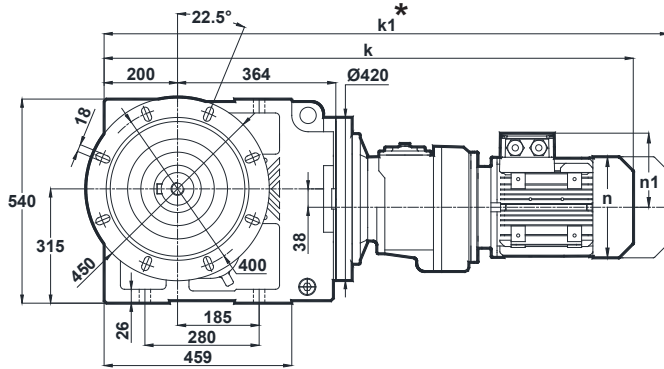

Klemens Pozisyonları  
Terminal Box Positions  
Klemmenkasten Positionen

	71	80	90S	90L	100L
k	1019	1053	1092	1092	1140
k1	1110	1146	1196.5	1196.5	1259.5
n	137	155	176	176	193
n1	112	121	132	132	147

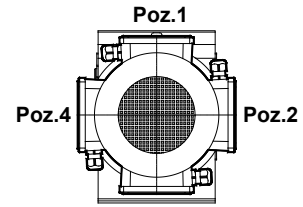

Poz.3  
71-80-90-100  
Tip / Type / Typ

KR775.03  
KR776.03

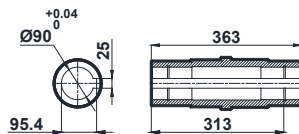
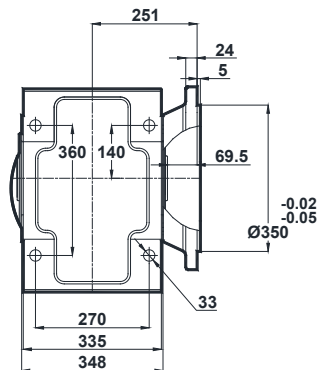
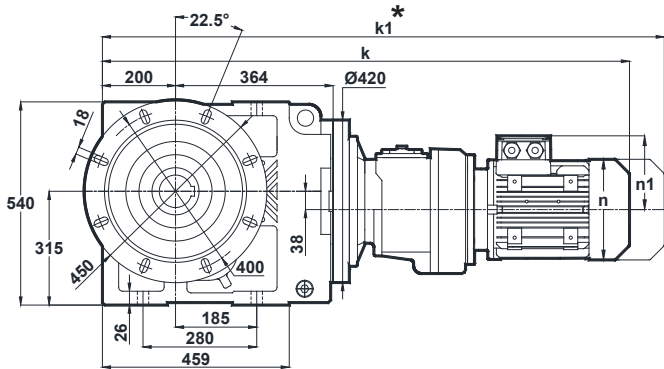

	71	80	90S	90L	100L
k	1019	1053	1092	1092	1140
k1	1110	1146	1196.5	1196.5	1259.5
n	137	155	176	176	193
n1	112	121	132	132	147

\* "k1" Ölçüsü frenli redüktörlere aittir.  
Dimension "k1" is for motors with brake.  
Maße "k1" ist für Bremsenmotoren.

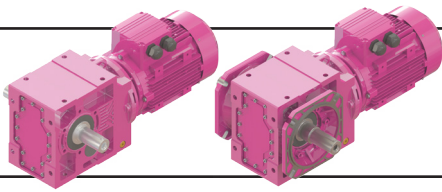

# Ölçü Sayfaları

## Dimension Pages

### Abmessungsseiten

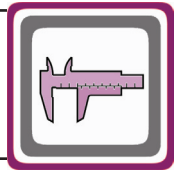

-Mil ucu çekirme deliği DIN 332 sayfa 2 / Tapped center hole to DIN 332, sheet 2 / Zentrierung mit Gewinde DIN 332, Blatt 2

KR775.04  
KR776.04

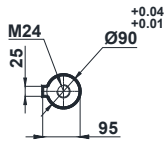
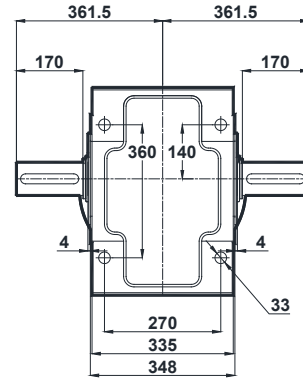
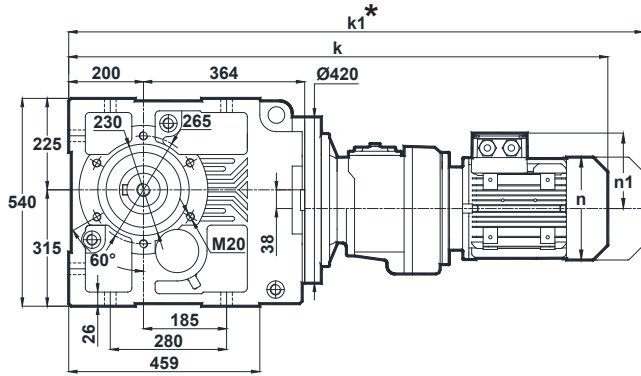

Klemens Pozisyonları  
Terminal Box Positions  
Klemmenkasten Positionen

	71	80	90S	90L	100L
k	1019	1053	1092	1092	1140
k1	1110	1146	1196.5	1196.5	1259.5
n	137	155	176	176	193
n1	112	121	132	132	147

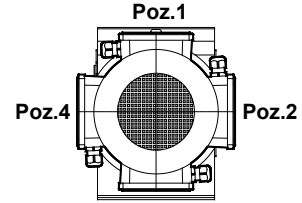

Poz.3  
71-80-90-100  
Tip / Type / Typ

KR775.05  
KR776.05

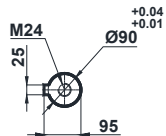
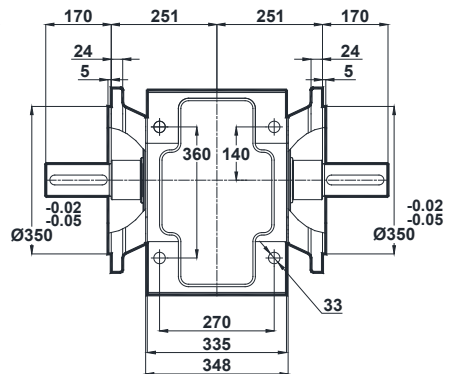
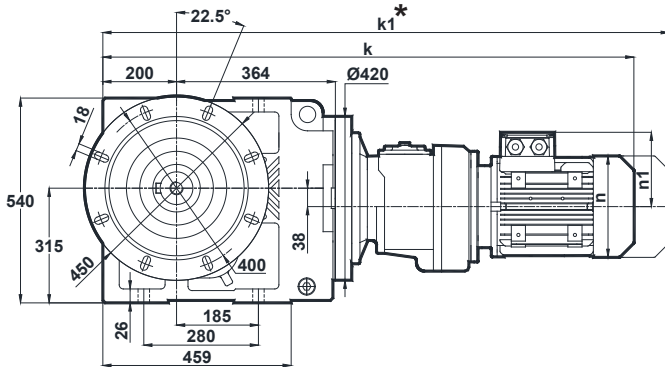

	71	80	90S	90L	100L
k	1019	1053	1092	1092	1140
k1	1110	1146	1196.5	1196.5	1259.5
n	137	155	176	176	193
n1	112	121	132	132	147

\* "k1" Ölçüsü frenli redüktörlere aittir.  
Dimension "k1" is for motors with brake.  
Maße "k1" ist für Bremsenmotoren.

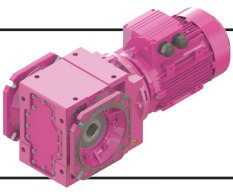

# Ölçü Sayfaları

## Dimension Pages

### Abmessungsseiten

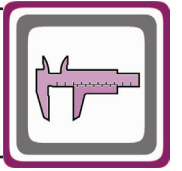

-Mil ucu çektirme deliği DIN 332 sayfa 2 / Tapped center hole to DIN 332, sheet 2 / Zentrierung mit Gewinde DIN 332, Blatt 2

KR775.08  
KR776.08

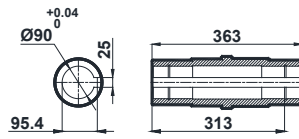
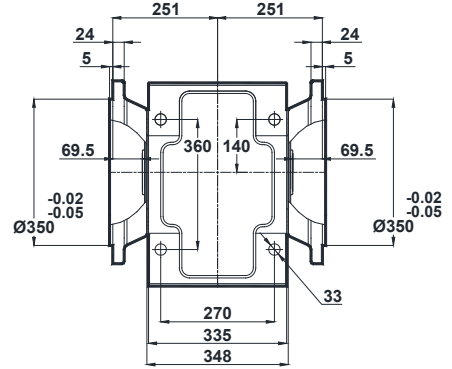
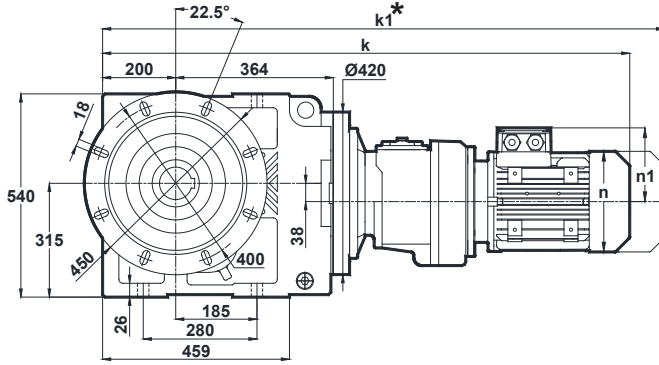

**Klemens Pozisyonları**  
Terminal Box Positions  
Klemmenkasten Positionen

	71	80	90S	90L	100L
k	1019	1053	1092	1092	1140
k1	1110	1146	1196.5	1196.5	1259.5
n	137	155	176	176	193
n1	112	121	132	132	147

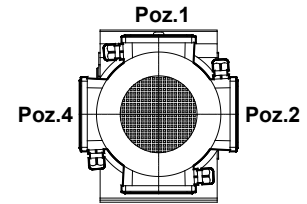

**Poz.3**  
71-80-90-100  
Tip / Type / Typ

\* "k1" Ölçüsü frenli redüktörlere aittir.  
Dimension "k1" is for motors with brake.  
Maße "k1" ist für Bremsenmotoren.

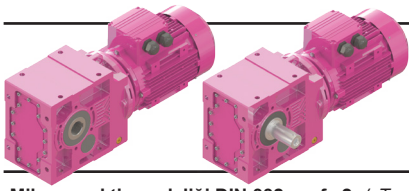

# Ölçü Sayfaları

## Dimension Pages

### Abmessungsseiten

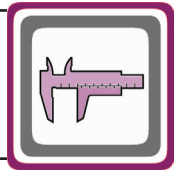

-Mil ucu çektirme deliği DIN 332 sayfa 2 / Tapped center hole to DIN 332, sheet 2 / Zentrierung mit Gewinde DIN 332, Blatt 2

#### KR873.00

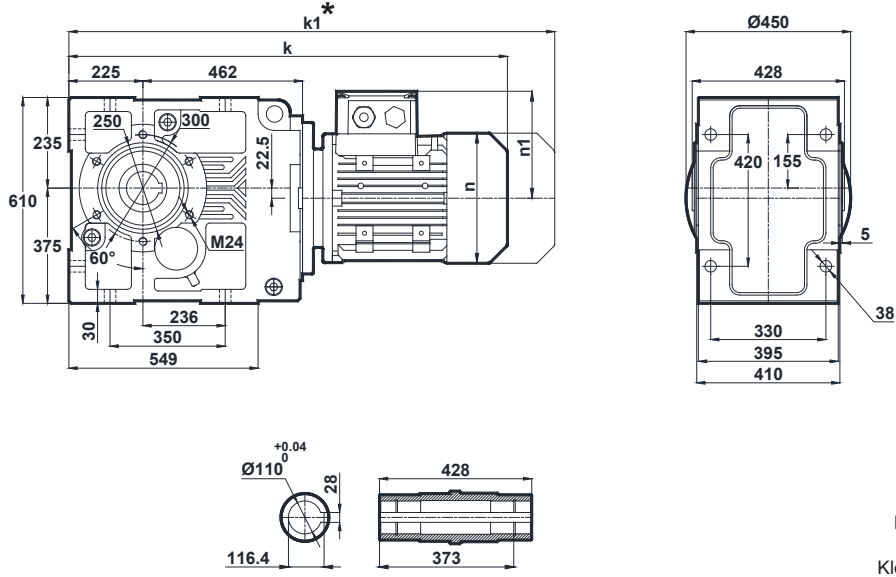

**Klemens Pozisyonları**  
Terminal Box Positions  
Klemmenkasten Positionen

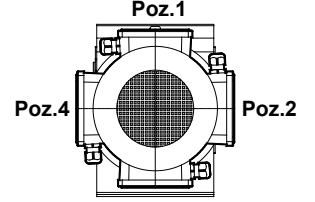

**Poz.1**  
**Poz.2**  
**Poz.3**  
**Poz.4**  
132-160-180-200-225-250-280  
Tip / Type / Typ

	160M	160L	180M	180L	200L	225S	225M	250M	280S	280M
<b>k</b>	1188	1188	1259	1259	1293	1309	1334	1437	1498	1498
<b>k1</b>	1368	1368	1429.5	1429.5	1479.5	1474	1499	1607.5	1671	1677
<b>n</b>	315	315	347	347	390	434	434	480	544	544
<b>n1</b>	219	219	234	234	275	285	285	322	350	350

#### KR873.01

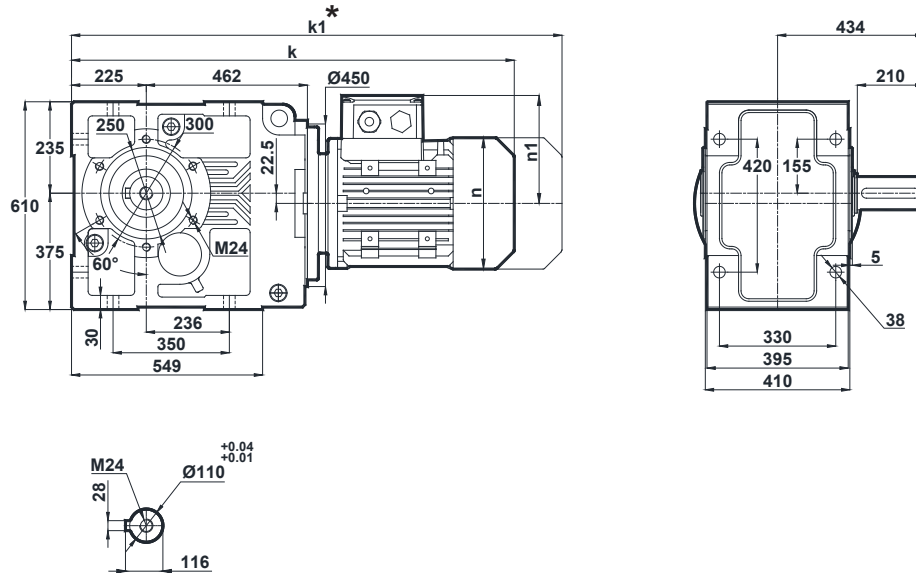

	160M	160L	180M	180L	200L	225S	225M	250M	280S	280M
<b>k</b>	1188	1188	1259	1259	1293	1309	1334	1437	1498	1498
<b>k1</b>	1368	1368	1429.5	1429.5	1479.5	1474	1499	1607.5	1671	1677
<b>n</b>	315	315	347	347	390	434	434	480	544	544
<b>n1</b>	219	219	234	234	275	285	285	322	350	350

\* " k1 " Ölçüsü frenli redüktörlere aittir.  
Dimension " k1 " is for motors with brake.  
Maße " k1 " ist für Bremsenmotoren.

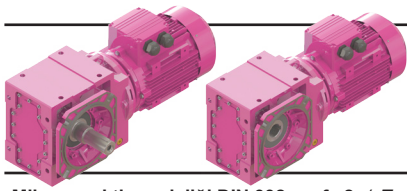

# Ölçü Sayfaları

## Dimension Pages

### Abmessungsseiten

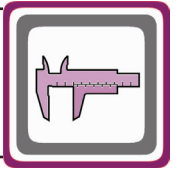

-Mil ucu çektirme deliği DIN 332 sayfa 2 / Tapped center hole to DIN 332, sheet 2 / Zentrierung mit Gewinde DIN 332, Blatt 2

#### KR873.02

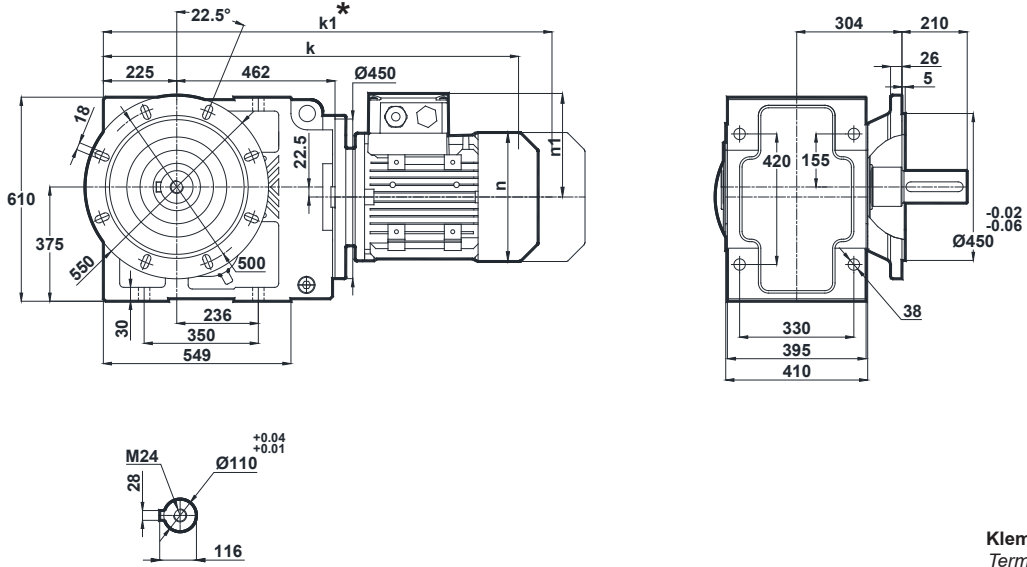

Klemens Pozisyonları  
Terminal Box Positions  
Klemmenkasten Positionen

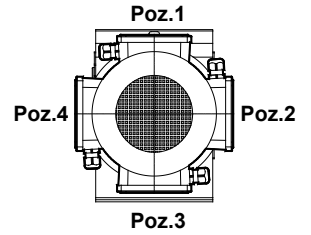

132-160-180-200-225-250-280  
Tip / Type / Typ

	160M	160L	180M	180L	200L	225S	225M	250M	280S	280M
k	1188	1188	1259	1259	1293	1309	1334	1437	1498	1498
k1	1368	1368	1429.5	1429.5	1479.5	1474	1499	1607.5	1671	1677
n	315	315	347	347	390	434	434	480	544	544
n1	219	219	234	234	275	285	285	322	350	350

#### KR873.03

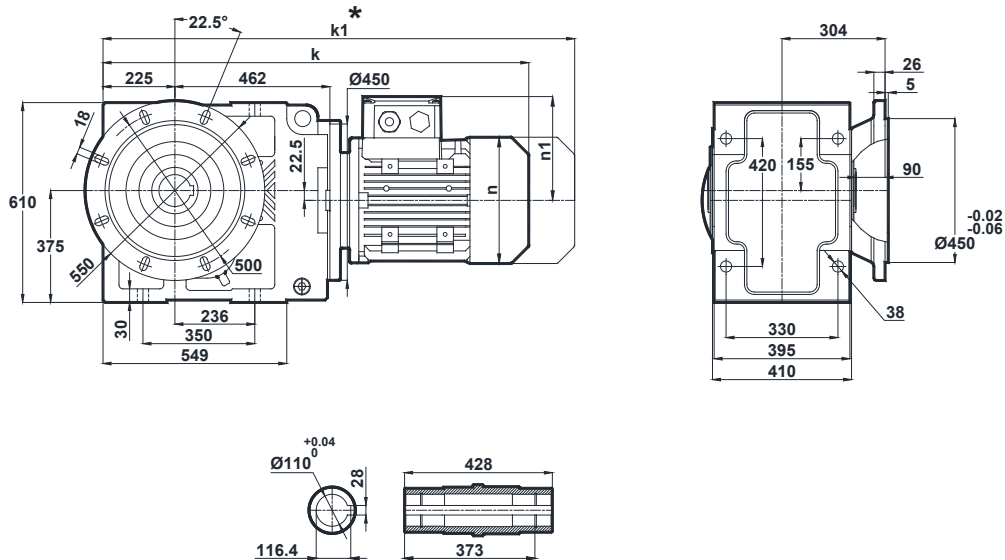

	160M	160L	180M	180L	200L	225S	225M	250M	280S	280M
k	1188	1188	1259	1259	1293	1309	1334	1437	1498	1498
k1	1368	1368	1429.5	1429.5	1479.5	1474	1499	1607.5	1671	1677
n	315	315	347	347	390	434	434	480	544	544
n1	219	219	234	234	275	285	285	322	350	350

\* "k1" Ölçüsü frenli redüktörlere aittir.  
Dimension "k1" is for motors with brake.  
Maße "k1" ist für Bremsenmotoren.

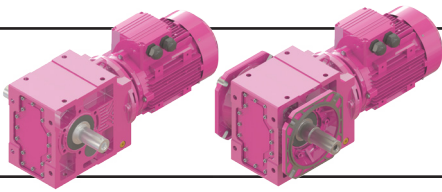

# Ölçü Sayfaları

## Dimension Pages

### Abmessungsseiten

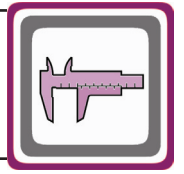

-Mil ucu çektirme deliği DIN 332 sayfa 2 / Tapped center hole to DIN 332, sheet 2 / Zentrierung mit Gewinde DIN 332, Blatt 2

#### KR873.04

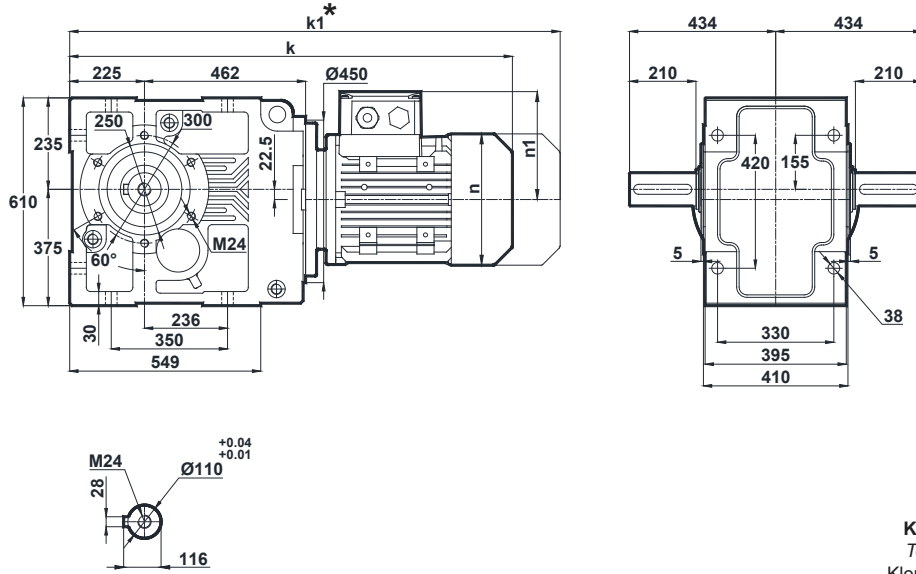

	160M	160L	180M	180L	200L	225S	225M	250M	280S	280M
k	1188	1188	1259	1259	1293	1309	1334	1437	1498	1498
k1	1368	1368	1429.5	1429.5	1479.5	1474	1499	1607.5	1671	1677
n	315	315	347	347	390	434	434	480	544	544
n1	219	219	234	234	275	285	285	322	350	350

**Klemens Pozisyonları**  
Terminal Box Positions  
Klemmenkasten Positionen

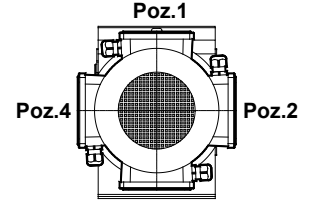

**Poz.3**  
132-160-180-200-225-250-280  
Tip / Type / Typ

#### KR873.05

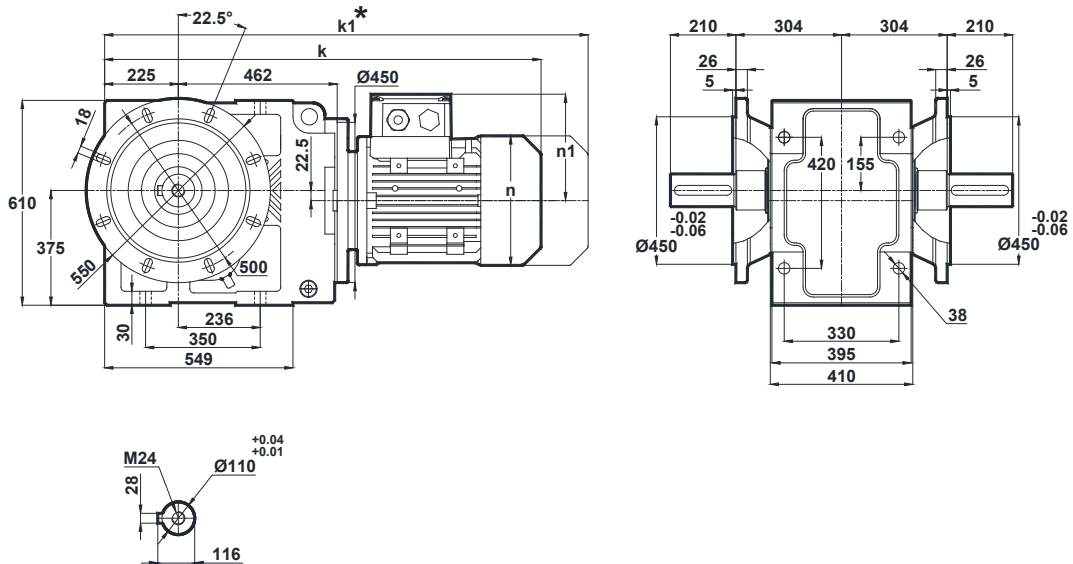

	160M	160L	180M	180L	200L	225S	225M	250M	280S	280M
k	1188	1188	1259	1259	1293	1309	1334	1437	1498	1498
k1	1368	1368	1429.5	1429.5	1479.5	1474	1499	1607.5	1671	1677
n	315	315	347	347	390	434	434	480	544	544
n1	219	219	234	234	275	285	285	322	350	350

\* "k1" Ölçüsü frenli redüktörlere aittir.  
Dimension "k1" is for motors with brake.  
Maße "k1" ist für Bremsenmotoren.



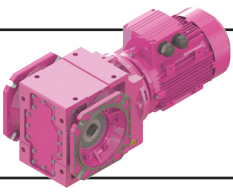

# Ölçü Sayfaları Dimension Pages Abmessungenseiten

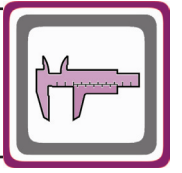

-Mil ucu çektirme deliği DIN 332 sayfa 2 / Tapped center hole to DIN 332, sheet 2 / Zentrierung mit Gewinde DIN 332, Blatt 2

KR873.08

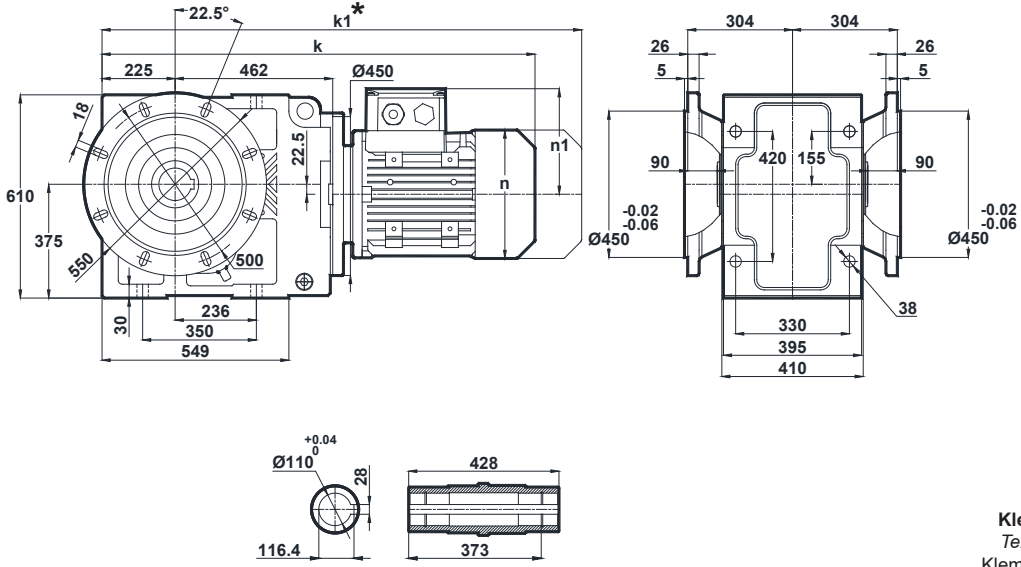

Klemens Pozisyonları  
Terminal Box Positions  
Klemmenkasten Positionen

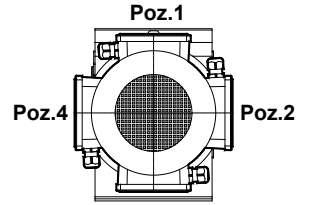

Poz.1  
Poz.2  
Poz.3  
Poz.4  
132-160-180-200-225-250-280  
Tip / Type / Typ

	160M	160L	180M	180L	200L	225S	225M	250M	280S	280M
k	1188	1188	1259	1259	1293	1309	1334	1437	1498	1498
k1	1368	1368	1429.5	1429.5	1479.5	1474	1499	1607.5	1671	1677
n	315	315	347	347	390	434	434	480	544	544
n1	219	219	234	234	275	285	285	322	350	350

\* "k1" Ölçüsü frenli redüktörlere aittir.  
Dimension "k1" is for motors with brake.  
Maße "k1" ist für Bremsenmotoren.

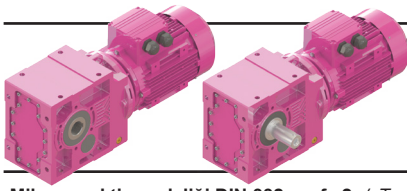

# Ölçü Sayfaları

## Dimension Pages

### Abmessungsseiten

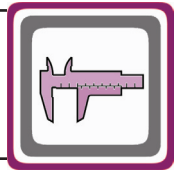

-Mil ucu çektirme deliği DIN 332 sayfa 2 / Tapped center hole to DIN 332, sheet 2 / Zentrierung mit Gewinde DIN 332, Blatt 2

#### KR874.00

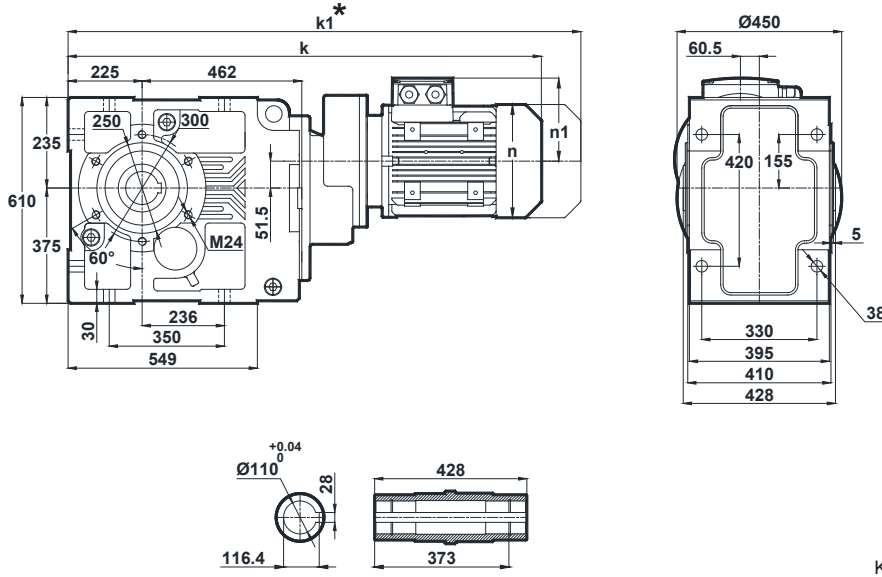

**Klemens Pozisyonları**  
Terminal Box Positions  
Klemmenkasten Positionen

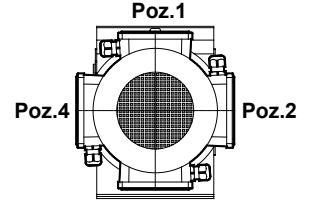

**Poz.3**  
100-112-132-160-180  
Tip / Type / Typ

	100L	112M	132S	132M	160M	160L	180M
k	1123	1147	1234	1234	1330	1330	1401
k1	1242.5	1251.5	1364	1364	1510	1510	1571.5
n	193	215	257	257	315	315	347
n1	147	158	179	179	219	219	234

#### KR874.01

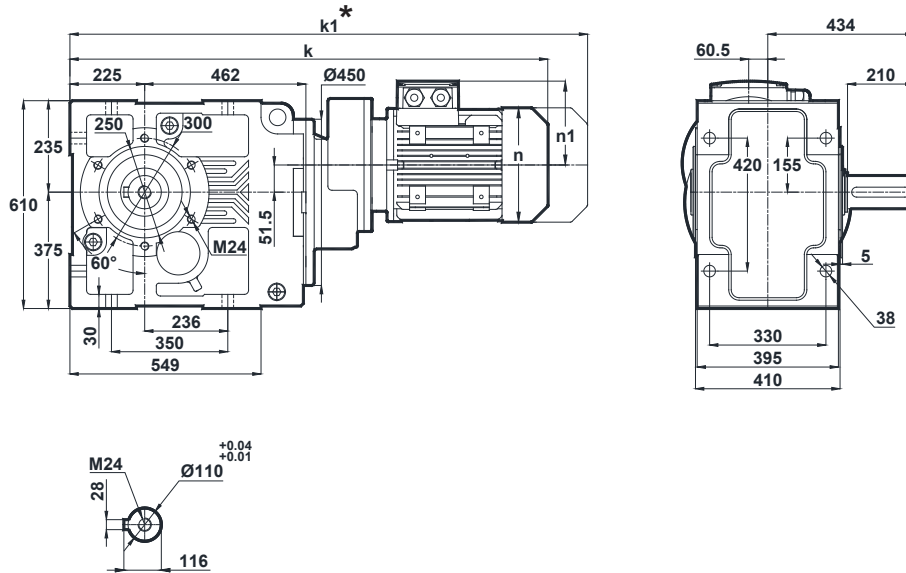

	100L	112M	132S	132M	160M	160L	180M
k	1123	1147	1234	1234	1330	1330	1401
k1	1242.5	1251.5	1364	1364	1510	1510	1571.5
n	193	215	257	257	315	315	347
n1	147	158	179	179	219	219	234

\* "k1" Ölçüsü frenli redüktörlere aittir.  
Dimension "k1" is for motors with brake.  
Maße "k1" ist für Bremsenmotoren.

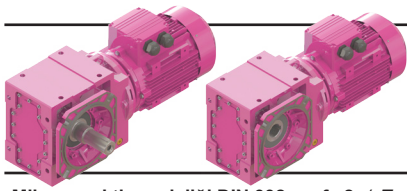

# Ölçü Sayfaları

## Dimension Pages

### Abmessungsseiten

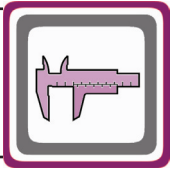

-Mil ucu çektirme deliği DIN 332 sayfa 2 / Tapped center hole to DIN 332, sheet 2 / Zentrierung mit Gewinde DIN 332, Blatt 2

#### KR874.02

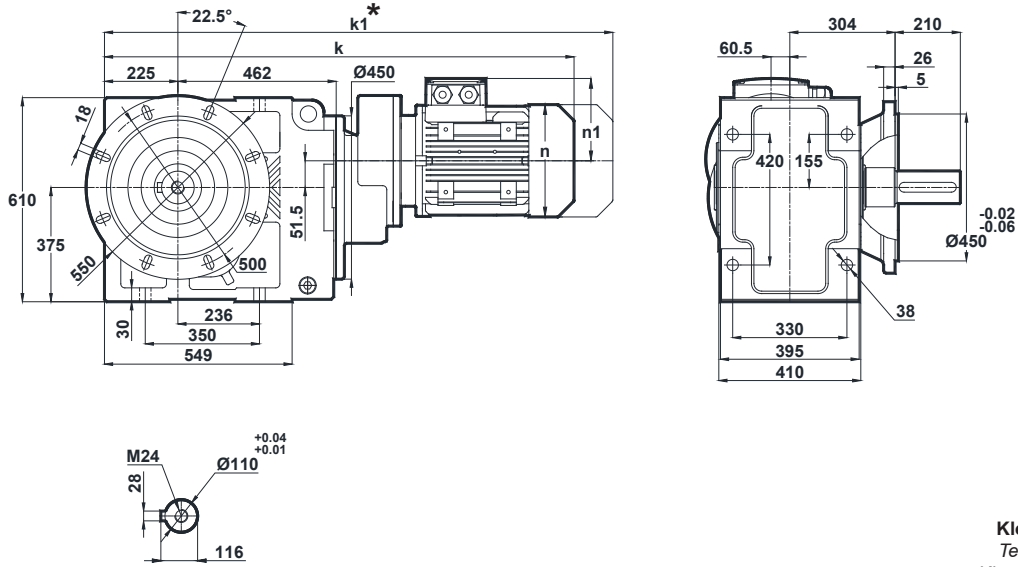

	100L	112M	132S	132M	160M	160L	180M
k	1123	1147	1234	1234	1330	1330	1401
k1	1242.5	1251.5	1364	1364	1510	1510	1571.5
n	193	215	257	257	315	315	347
n1	147	158	179	179	219	219	234

**Klemens Pozisyonları**  
Terminal Box Positions  
Klemmenkasten Positionen

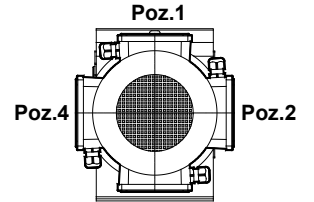

Poz.3

100-112-132-160-180  
Tip / Type / Typ

#### KR874.03

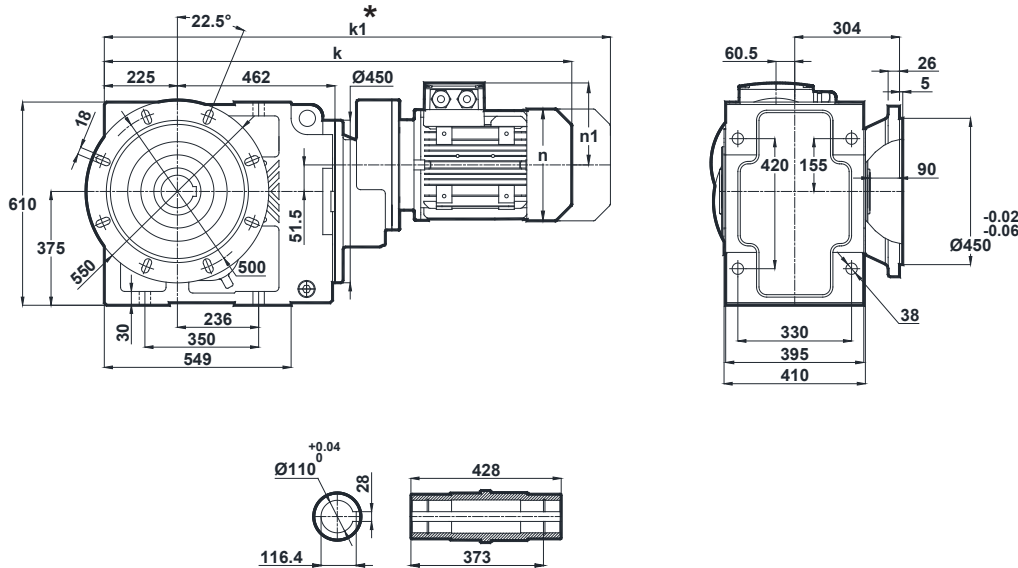

	100L	112M	132S	132M	160M	160L	180M
k	1123	1147	1234	1234	1330	1330	1401
k1	1242.5	1251.5	1364	1364	1510	1510	1571.5
n	193	215	257	257	315	315	347
n1	147	158	179	179	219	219	234

\* "k1" Ölçüsü frenli redüktörlere aittir.  
Dimension "k1" is for motors with brake.  
Maße "k1" ist für Bremsenmotoren.

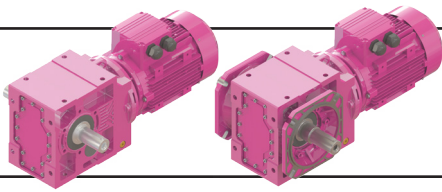

# Ölçü Sayfaları

## Dimension Pages

### Abmessungsseiten

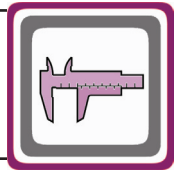

-Mil ucu çektirme deliği DIN 332 sayfa 2 / Tapped center hole to DIN 332, sheet 2 / Zentrierung mit Gewinde DIN 332, Blatt 2

#### KR874.04

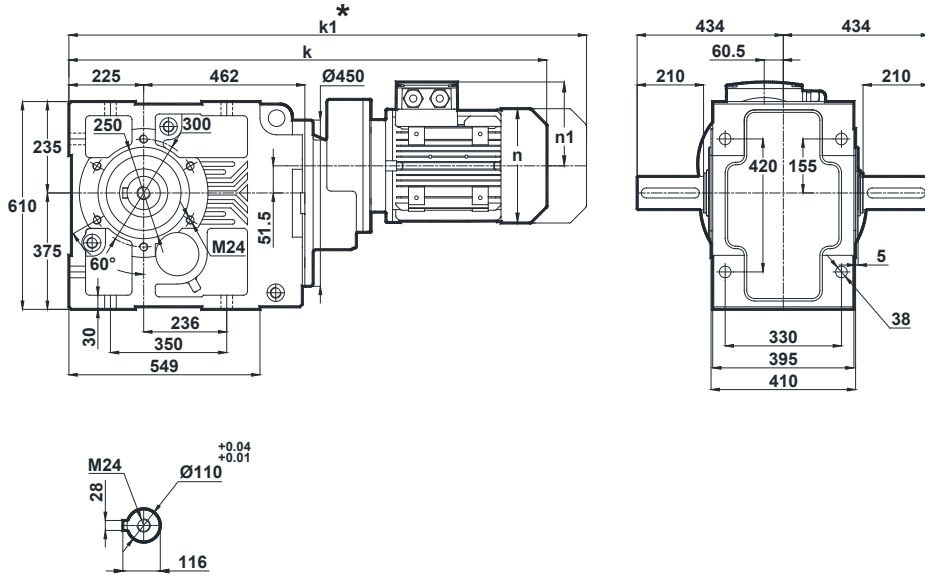

	100L	112M	132S	132M	160M	160L	180M
k	1123	1147	1234	1234	1330	1330	1401
k1	1242.5	1251.5	1364	1364	1510	1510	1571.5
n	193	215	257	257	315	315	347
n1	147	158	179	179	219	219	234

Klemens Pozisyonları  
Terminal Box Positions  
Klemmenkasten Positionen

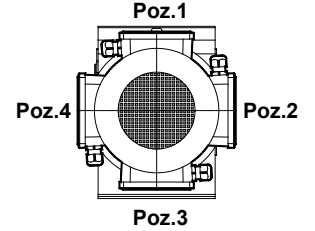

100-112-132-160-180  
Tip / Type / Typ

#### KR874.05

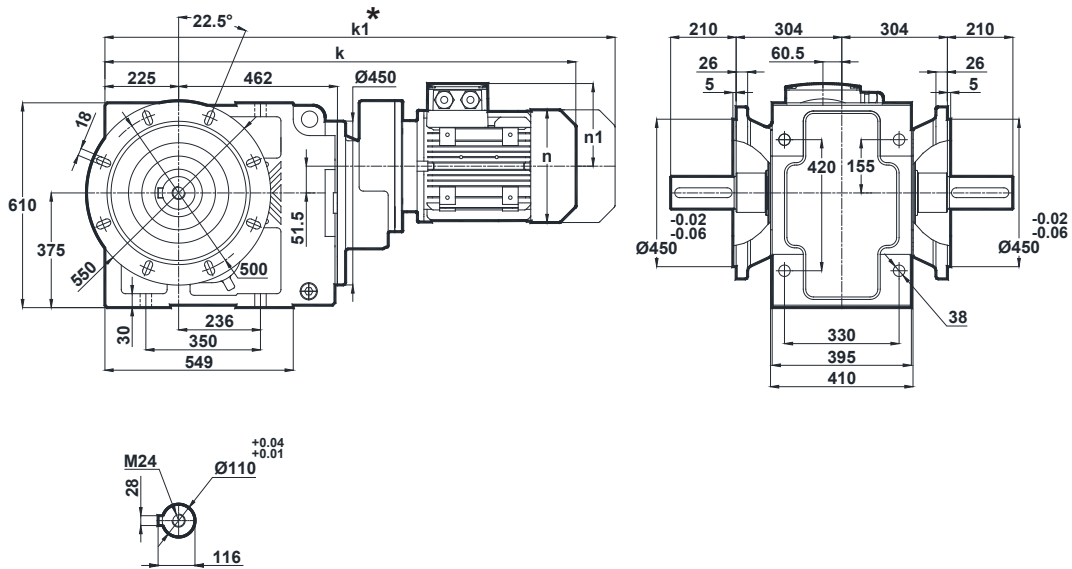

	100L	112M	132S	132M	160M	160L	180M
k	1123	1147	1234	1234	1330	1330	1401
k1	1242.5	1251.5	1364	1364	1510	1510	1571.5
n	193	215	257	257	315	315	347
n1	147	158	179	179	219	219	234

\* "k1" Ölçüsü frenli redüktörlere aittir.  
Dimension "k1" is for motors with brake.  
Maße "k1" ist für Bremsenmotoren.

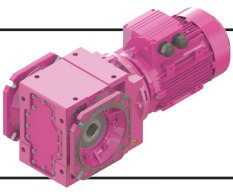

# Ölçü Sayfaları Dimension Pages Abmessungsseiten

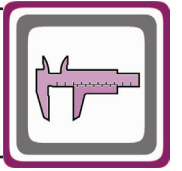

-Mil ucu çektirme deliği DIN 332 sayfa 2 / Tapped center hole to DIN 332, sheet 2 / Zentrierung mit Gewinde DIN 332, Blatt 2

KR874.08

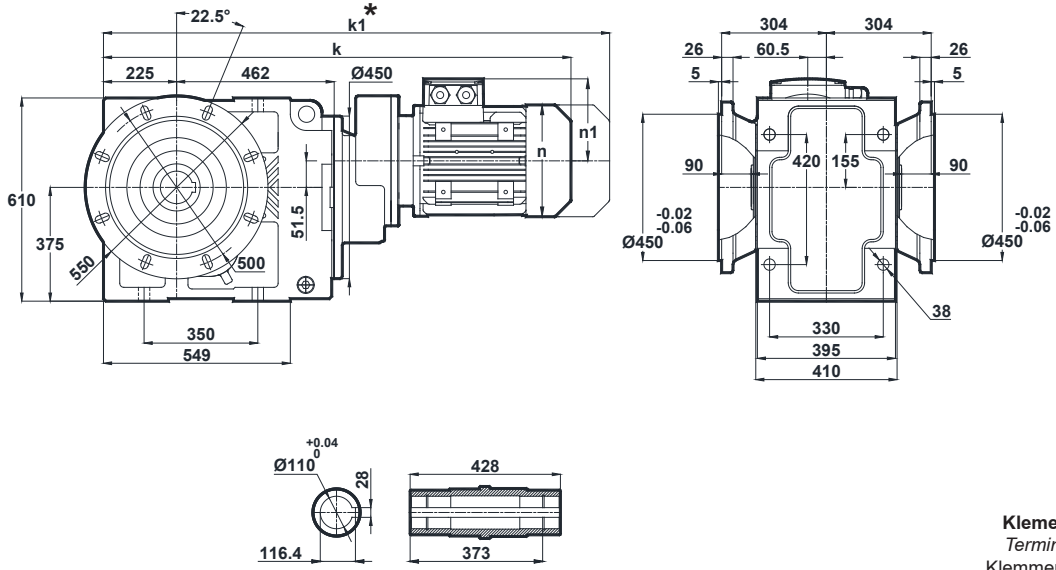

	100L	112M	132S	132M	160M	160L	180M
k	1123	1147	1234	1234	1330	1330	1401
k1	1242.5	1251.5	1364	1364	1510	1510	1571.5
n	193	215	257	257	315	315	347
n1	147	158	179	179	219	219	234

Klemens Pozisyonları  
Terminal Box Positions  
Klemmenkasten Positionen

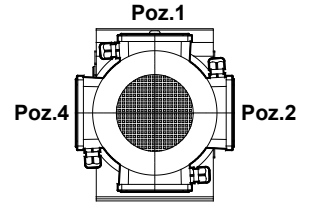

Poz.1

Poz.2

Poz.3

Poz.4

100-112-132-160-180  
Tip / Type / Typ

\* "k1" Ölçüsü frenli redüktörlere aittir.  
Dimension "k1" is for motors with brake.  
Maße "k1" ist für Bremsenmotoren.

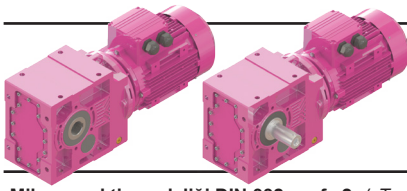

# Ölçü Sayfaları

## Dimension Pages

### Abmessungsseiten

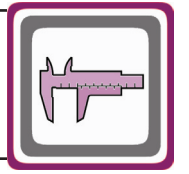

-Mil ucu çekirme deliği DIN 332 sayfa 2 / Tapped center hole to DIN 332, sheet 2 / Zentrierung mit Gewinde DIN 332, Blatt 2

KR875.00  
KR876.00

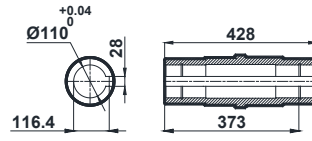
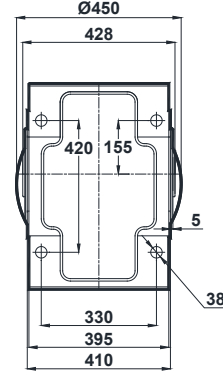
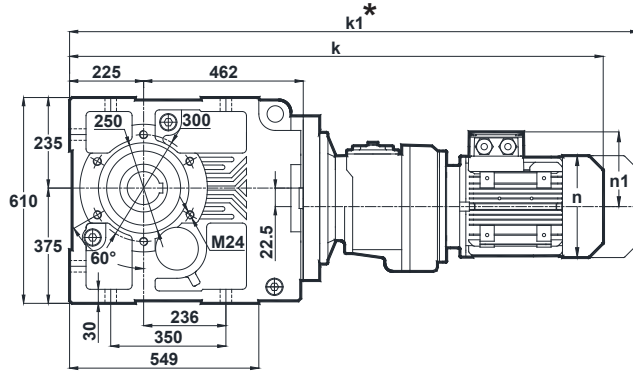

Klemens Pozisyonları  
Terminal Box Positions  
Klemmenkasten Positionen

	71	80	90S	90L	100L	112M
k	1142	1176	1215	1215	1263	1287
k1	1233	1269	1319.5	1319.5	1382.5	1391.5
n	137	155	176	176	193	215
n1	112	121	132	132	147	158

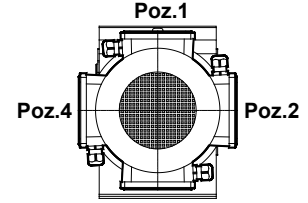

Poz.3  
71-80-90-100-112-132  
Tip / Type / Typ

KR875.01  
KR876.01

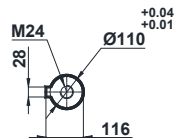
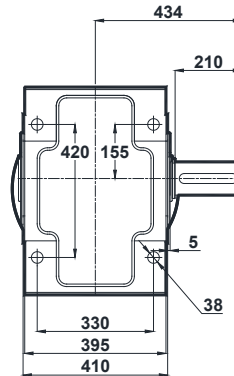
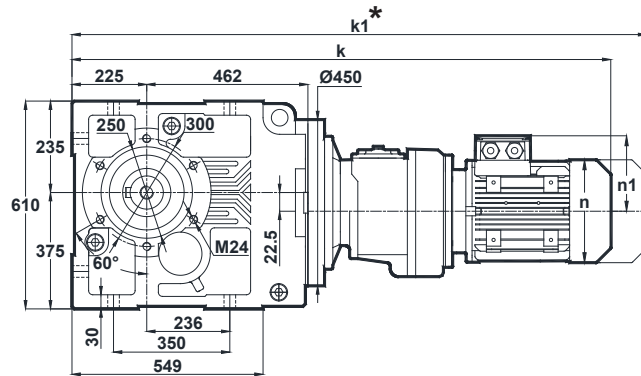

	71	80	90S	90L	100L	112M
k	1142	1176	1215	1215	1263	1287
k1	1233	1269	1319.5	1319.5	1382.5	1391.5
n	137	155	176	176	193	215
n1	112	121	132	132	147	158

\* "k1" Ölçüsü frenli redüktörlere aittir.  
Dimension "k1" is for motors with brake.  
Maße "k1" ist für Bremsenmotoren.

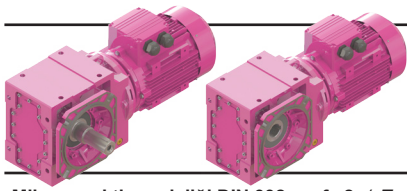

# Ölçü Sayfaları

## Dimension Pages

### Abmessungsseiten

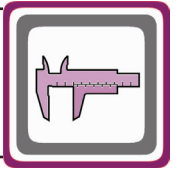

-Mil ucu çektirme deliği DIN 332 sayfa 2 / Tapped center hole to DIN 332, sheet 2 / Zentrierung mit Gewinde DIN 332, Blatt 2

KR875.02  
KR876.02

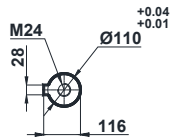
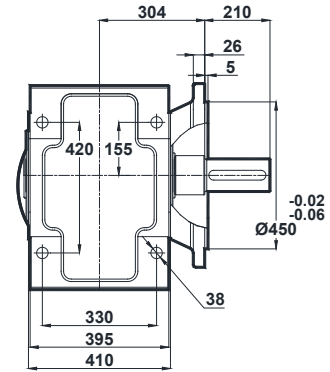
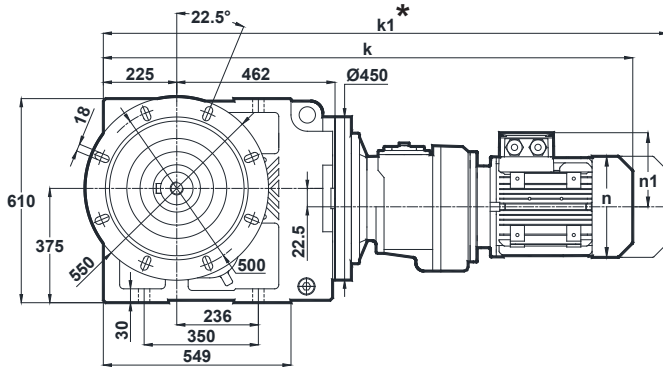

Klemens Pozisyonları  
Terminal Box Positions  
Klemmenkasten Positionen

	71	80	90S	90L	100L	112M
k	1142	1176	1215	1215	1263	1287
k1	1233	1269	1319.5	1319.5	1382.5	1391.5
n	137	155	176	176	193	215
n1	112	121	132	132	147	158

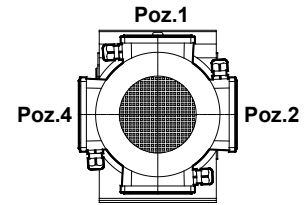

Poz.1  
Poz.2  
Poz.3  
Poz.4  
71-80-90-100-112-132  
Tip / Type / Typ

KR875.03  
KR876.03

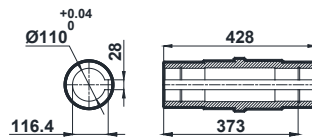
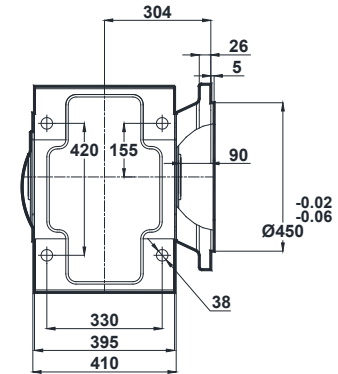
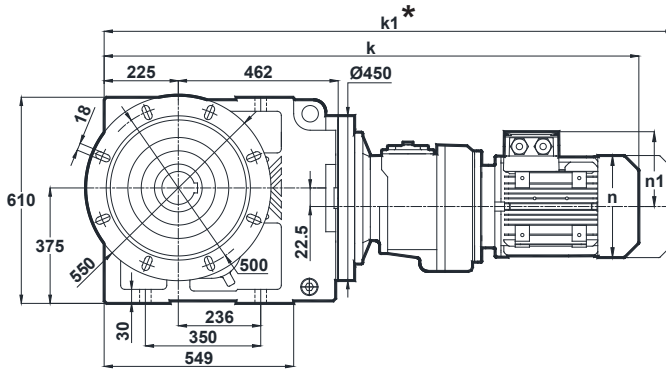

	71	80	90S	90L	100L	112M
k	1142	1176	1215	1215	1263	1287
k1	1233	1269	1319.5	1319.5	1382.5	1391.5
n	137	155	176	176	193	215
n1	112	121	132	132	147	158

\* "k1" Ölçüsü frenli redüktörlere aittir.  
Dimension "k1" is for motors with brake.  
Maße "k1" ist für Bremsenmotoren.

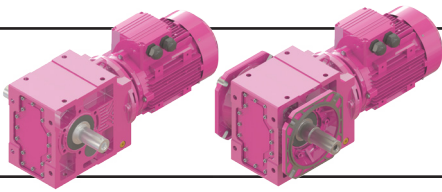

# Ölçü Sayfaları Dimension Pages Abmessungsseiten

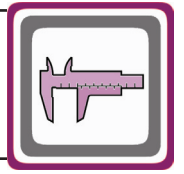

-Mil ucu çektirme deliği DIN 332 sayfa 2 / Tapped center hole to DIN 332, sheet 2 / Zentrierung mit Gewinde DIN 332, Blatt 2

KR875.04  
KR876.04

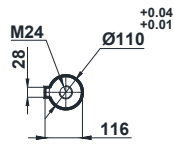
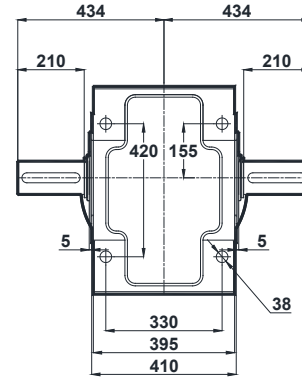
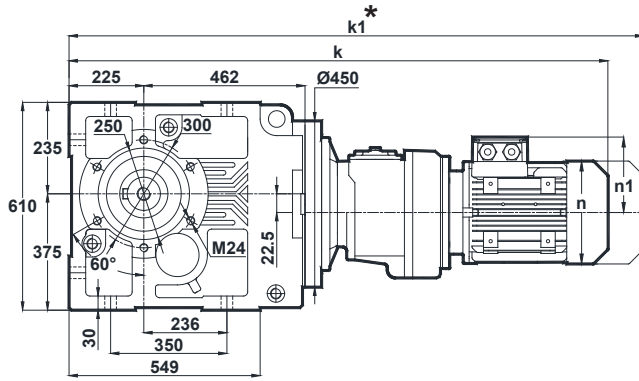

	71	80	90S	90L	100L	112M
k	1142	1176	1215	1215	1263	1287
k1	1233	1269	1319.5	1319.5	1382.5	1391.5
n	137	155	176	176	193	215
n1	112	121	132	132	147	158

Klemens Pozisyonları  
Terminal Box Positions  
Klemmenkasten Positionen

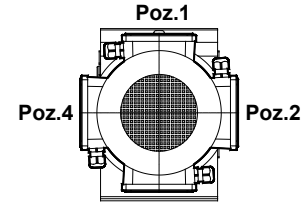

Poz.3  
71-80-90-100-112-132  
Tip / Type / Typ

KR875.05  
KR876.05

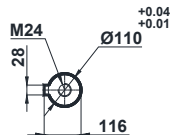
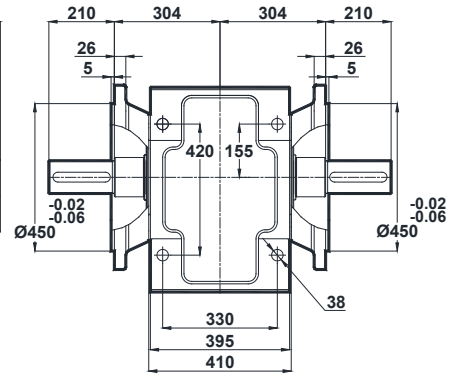
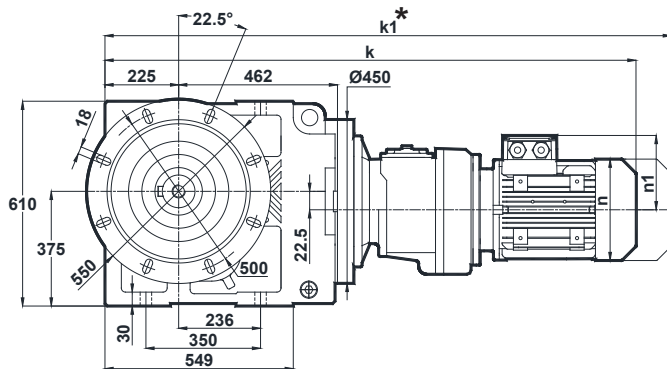

	71	80	90S	90L	100L	112M
k	1142	1176	1215	1215	1263	1287
k1	1233	1269	1319.5	1319.5	1382.5	1391.5
n	137	155	176	176	193	215
n1	112	121	132	132	147	158

\* "k1" Ölçüsü frenli redüktörlere aittir.  
Dimension "k1" is for motors with brake.  
Maße "k1" ist für Bremsenmotoren.



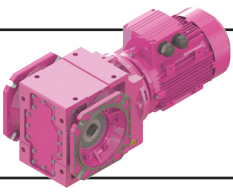

# Ölçü Sayfaları

## Dimension Pages

### Abmessungsseiten

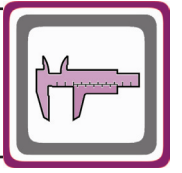

-Mil ucu çektirme deliği DIN 332 sayfa 2 / Tapped center hole to DIN 332, sheet 2 / Zentrierung mit Gewinde DIN 332, Blatt 2

KR875.08  
KR876.08

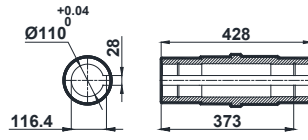
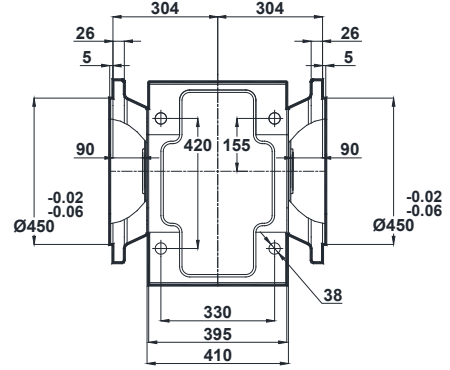
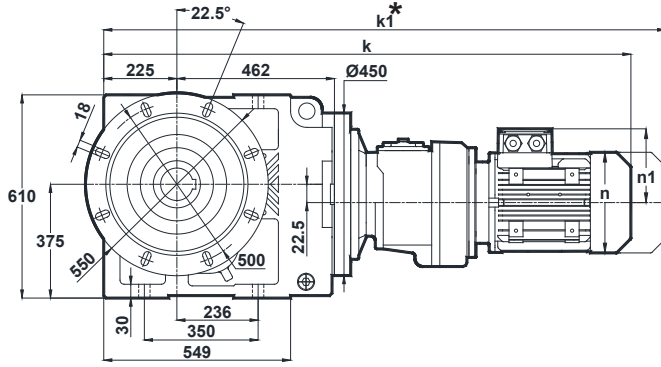

**Klemens Pozisyonları**  
Terminal Box Positions  
Klemmenkasten Positionen

	71	80	90S	90L	100L	112M
<b>k</b>	1142	1176	1215	1215	1263	1287
<b>k1</b>	1233	1269	1319.5	1319.5	1382.5	1391.5
<b>n</b>	137	155	176	176	193	215
<b>n1</b>	112	121	132	132	147	158

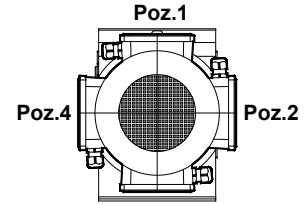

**Poz.3**  
71-80-90-100-112-132  
Tip / Type / Typ

\* " k1 " Ölçüsü frenli redüktörlere aittir.  
Dimension " k1 " is for motors with brake.  
Maße " k1 " ist für Bremsenmotoren.

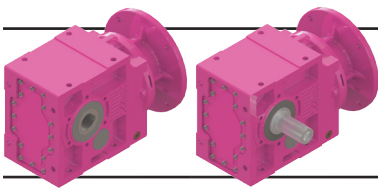

# Ölçü Sayfaları

## Dimension Pages

### Abmessungsseiten

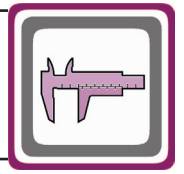

-Mil ucu çekirme deliği DIN 332 sayfa 2 / Tapped center hole to DIN 332, sheet 2 / Zentrierung mit Gewinde DIN 332, Blatt 2

KN002.00  
KN003.00

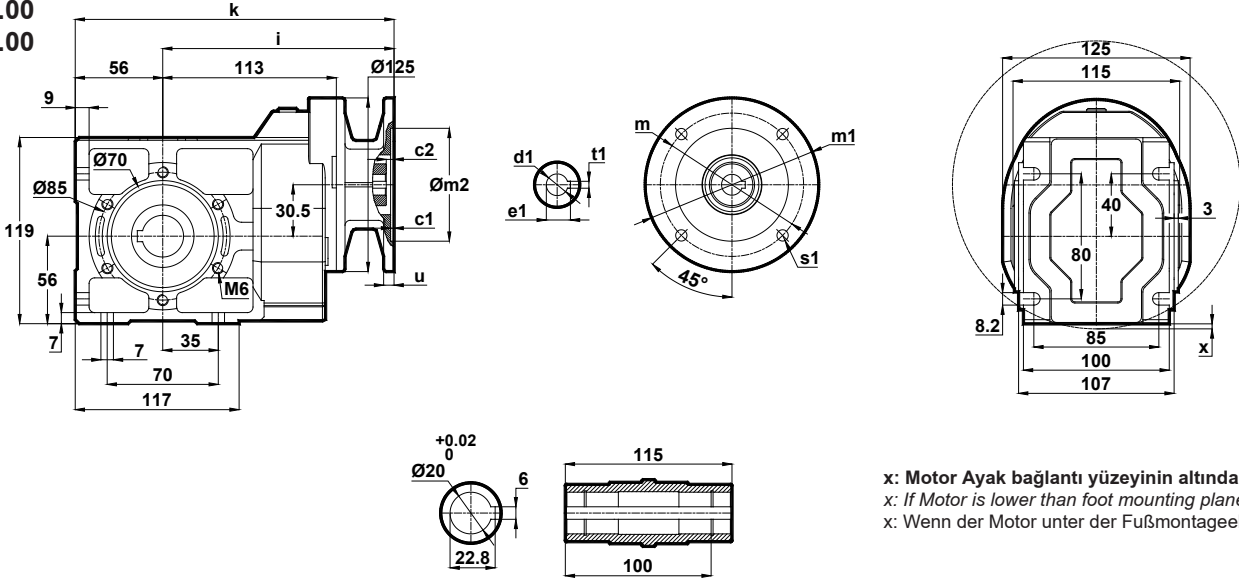

x: Motor Ayak bağlantı yüzeyinin altında ise  
x: If Motor is lower than foot mounting plane  
x: Wenn der Motor unter der Fußmontageebene ist

	c1	c2	s1	m	m1	m2	i	u	k	d1	t1	e1	x
63/B5	3.5	5	10	115	140	95	156	10	212	11	4	12.8	-
63/B14	2.5	5	5.5	75	90	60	156	10	212	11	4	12.8	-
71/B5	4	4.5	11	130	160	110	158	12	214	14	5	16.3	-
71/B14	3	4.5	7	85	105	70	158	10	214	14	5	16.3	-
80/B5	4	5	12	165	200	130	173	12	229	19	6	21.8	13.5
80/B14	4	5	7	100	120	80	173	12	229	19	6	21.8	-
90/B5	4	5	12	165	200	130	173	12	229	24	8	27.3	13.5
90/B14	4	5	9	115	140	95	173	12	229	24	8	27.3	-

KN002.01  
KN003.01

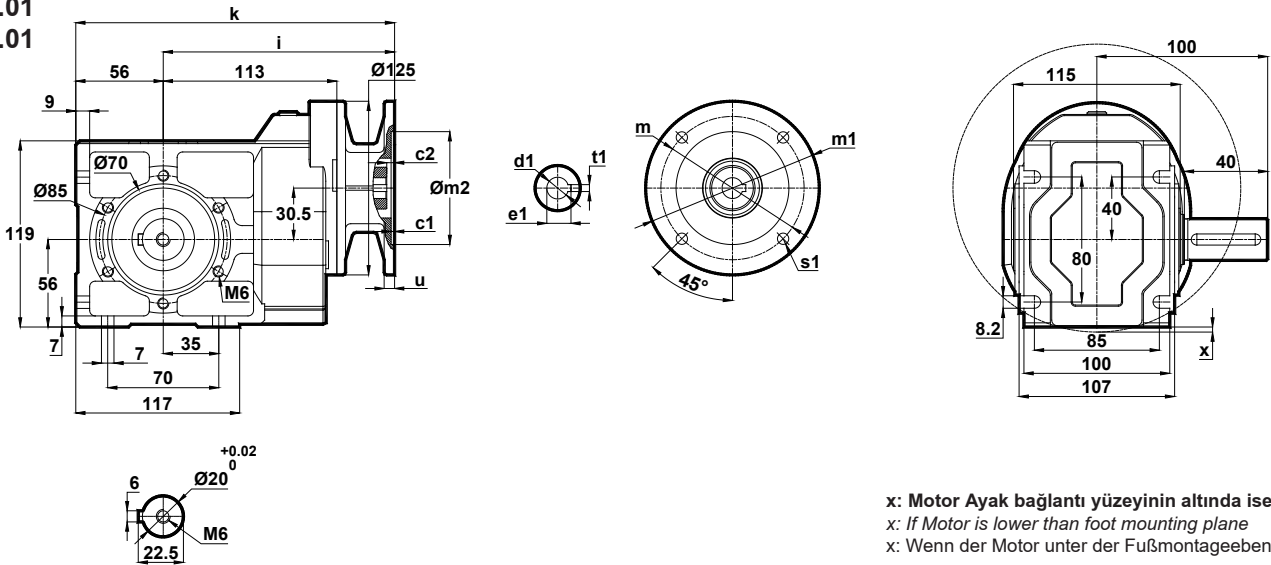

x: Motor Ayak bağlantı yüzeyinin altında ise  
x: If Motor is lower than foot mounting plane  
x: Wenn der Motor unter der Fußmontageebene ist

	c1	c2	s1	m	m1	m2	i	u	k	d1	t1	e1	x
63/B5	3.5	5	10	115	140	95	156	10	212	11	4	12.8	-
63/B14	2.5	5	5.5	75	90	60	156	10	212	11	4	12.8	-
71/B5	4	4.5	11	130	160	110	158	12	214	14	5	16.3	-
71/B14	3	4.5	7	85	105	70	158	10	214	14	5	16.3	-
80/B5	4	5	12	165	200	130	173	12	229	19	6	21.8	13.5
80/B14	4	5	7	100	120	80	173	12	229	19	6	21.8	-
90/B5	4	5	12	165	200	130	173	12	229	24	8	27.3	13.5
90/B14	4	5	9	115	140	95	173	12	229	24	8	27.3	-

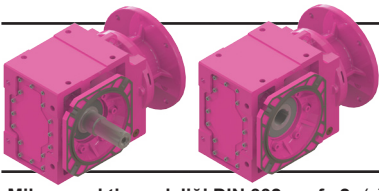

# Ölçü Sayfaları

## Dimension Pages

### Abmessungsseiten

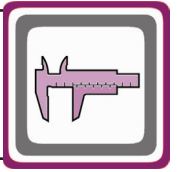

-Mil ucu çekirme deliği DIN 332 sayfa 2 / Tapped center hole to DIN 332, sheet 2 / Zentrierung mit Gewinde DIN 332, Blatt 2

KN002.02  
KN003.02

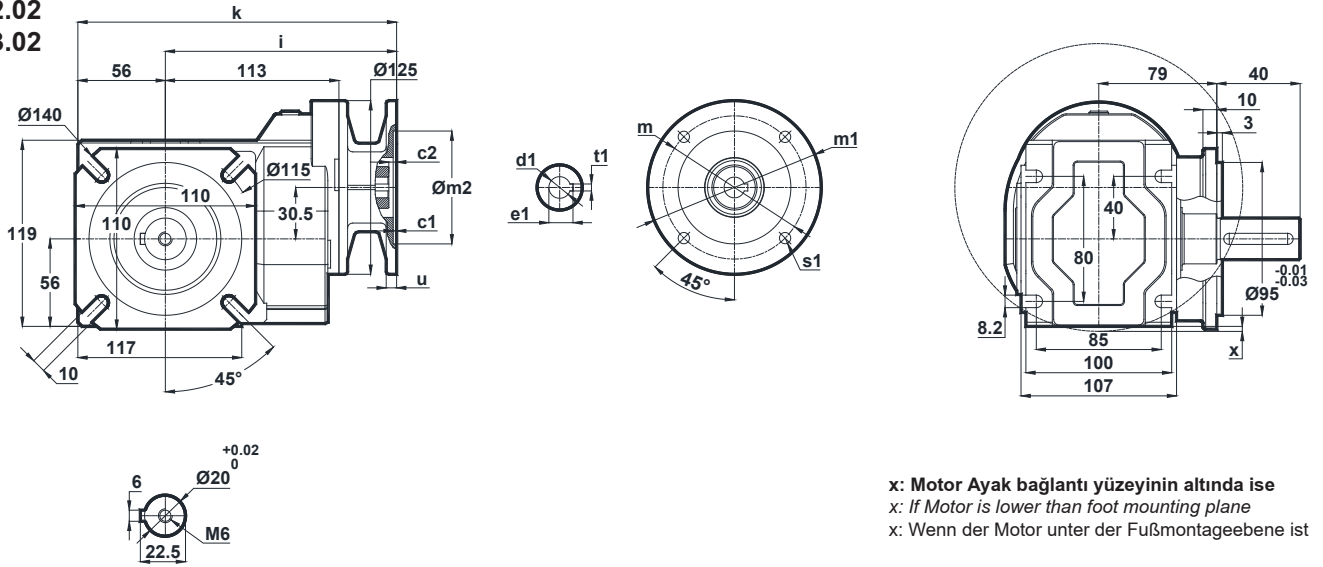

	c1	c2	s1	m	m1	m2	i	u	k	d1	t1	e1	x
63/B5	3.5	5	10	115	140	95	156	10	212	11	4	12.8	-
63/B14	2.5	5	5.5	75	90	60	156	10	212	11	4	12.8	-
71/B5	4	4.5	11	130	160	110	158	12	214	14	5	16.3	-
71/B14	3	4.5	7	85	105	70	158	10	214	14	5	16.3	-
80/B5	4	5	12	165	200	130	173	12	229	19	6	21.8	13.5
80/B14	4	5	7	100	120	80	173	12	229	19	6	21.8	-
90/B5	4	5	12	165	200	130	173	12	229	24	8	27.3	13.5
90/B14	4	5	9	115	140	95	173	12	229	24	8	27.3	-

KN002.03  
KN003.03

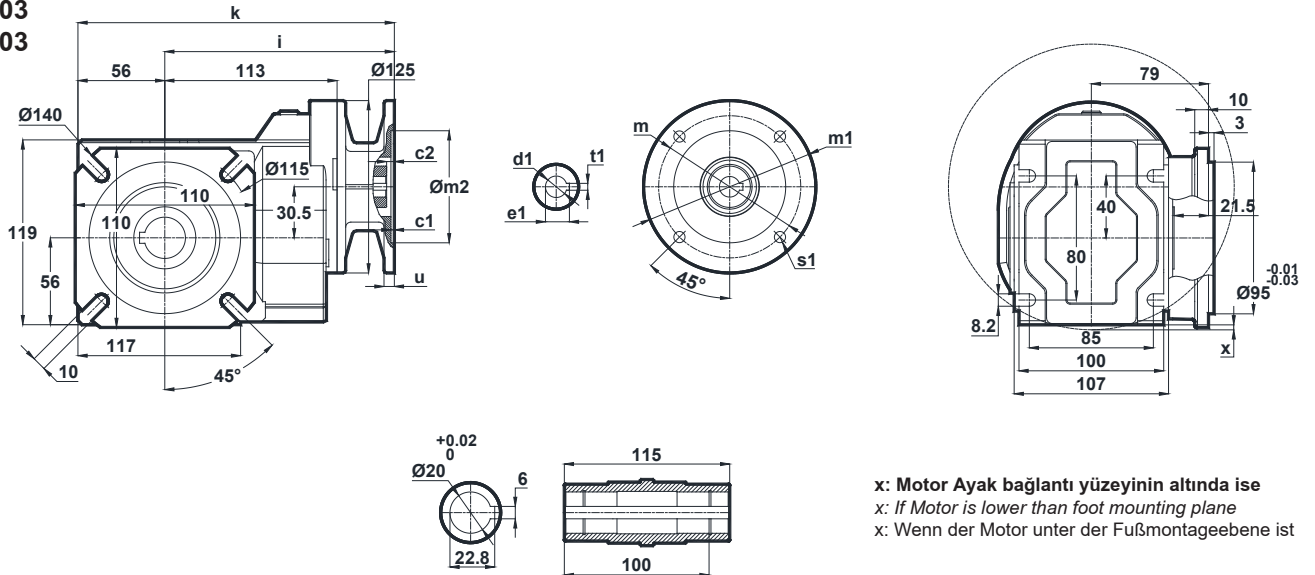

	c1	c2	s1	m	m1	m2	i	u	k	d1	t1	e1	x
63/B5	3.5	5	10	115	140	95	156	10	212	11	4	12.8	-
63/B14	2.5	5	5.5	75	90	60	156	10	212	11	4	12.8	-
71/B5	4	4.5	11	130	160	110	158	12	214	14	5	16.3	-
71/B14	3	4.5	7	85	105	70	158	10	214	14	5	16.3	-
80/B5	4	5	12	165	200	130	173	12	229	19	6	21.8	13.5
80/B14	4	5	7	100	120	80	173	12	229	19	6	21.8	-
90/B5	4	5	12	165	200	130	173	12	229	24	8	27.3	13.5
90/B14	4	5	9	115	140	95	173	12	229	24	8	27.3	-

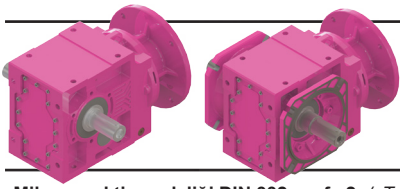

# Ölçü Sayfaları Dimension Pages Abmessungsseiten

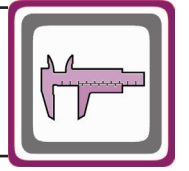

-Mil ucu çekirme deliği DIN 332 sayfa 2 / Tapped center hole to DIN 332, sheet 2 / Zentrierung mit Gewinde DIN 332, Blatt 2

KN002.04  
KN003.04

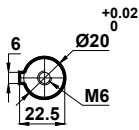
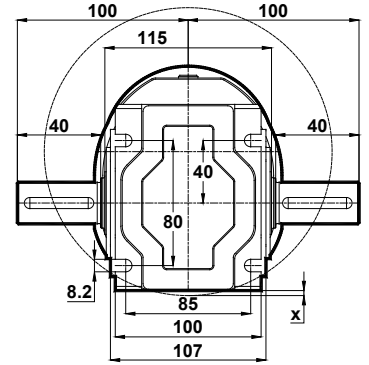
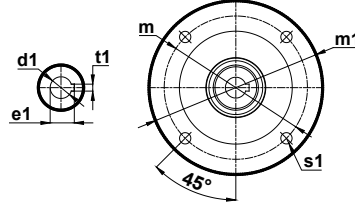
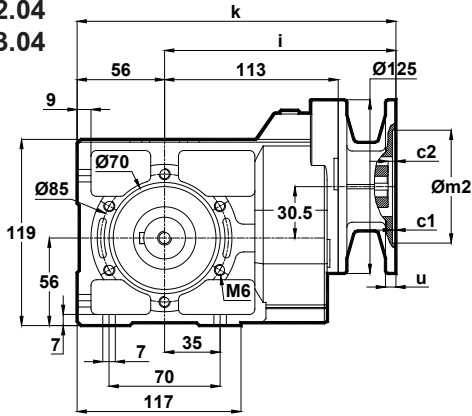

x: Motor Ayak bağlantı yüzeyinin altında ise  
x: If Motor is lower than foot mounting plane  
x: Wenn der Motor unter der Fußmontageebene ist

	c1	c2	s1	m	m1	m2	i	u	k	d1	t1	e1	x
63/B5	3.5	5	10	115	140	95	156	10	212	11	4	12.8	-
63/B14	2.5	5	5.5	75	90	60	156	10	212	11	4	12.8	-
71/B5	4	4.5	11	130	160	110	158	12	214	14	5	16.3	-
71/B14	3	4.5	7	85	105	70	158	10	214	14	5	16.3	-
80/B5	4	5	12	165	200	130	173	12	229	19	6	21.8	13.5
80/B14	4	5	7	100	120	80	173	12	229	19	6	21.8	-
90/B5	4	5	12	165	200	130	173	12	229	24	8	27.3	13.5
90/B14	4	5	9	115	140	95	173	12	229	24	8	27.3	-

KN002.05  
KN003.05

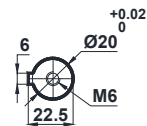
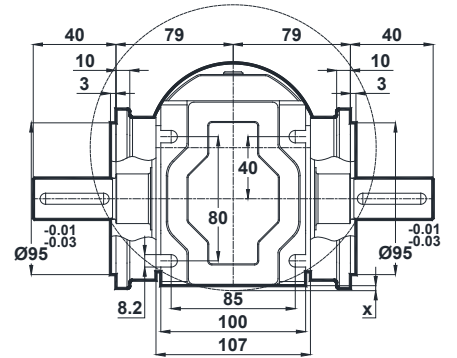
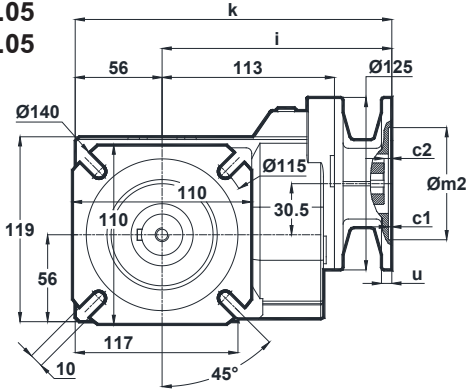

x: Motor Ayak bağlantı yüzeyinin altında ise  
x: If Motor is lower than foot mounting plane  
x: Wenn der Motor unter der Fußmontageebene ist

	c1	c2	s1	m	m1	m2	i	u	k	d1	t1	e1	x
63/B5	3.5	5	10	115	140	95	156	10	212	11	4	12.8	-
63/B14	2.5	5	5.5	75	90	60	156	10	212	11	4	12.8	-
71/B5	4	4.5	11	130	160	110	158	12	214	14	5	16.3	-
71/B14	3	4.5	7	85	105	70	158	10	214	14	5	16.3	-
80/B5	4	5	12	165	200	130	173	12	229	19	6	21.8	13.5
80/B14	4	5	7	100	120	80	173	12	229	19	6	21.8	-
90/B5	4	5	12	165	200	130	173	12	229	24	8	27.3	13.5
90/B14	4	5	9	115	140	95	173	12	229	24	8	27.3	-

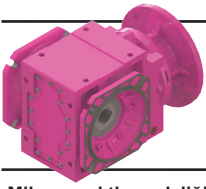

# Ölçü Sayfaları

## Dimension Pages

### Abmessungsseiten

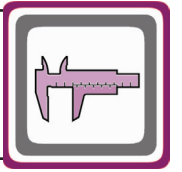

-Mil ucu çekirme deliği DIN 332 sayfa 2 / Tapped center hole to DIN 332, sheet 2 / Zentrierung mit Gewinde DIN 332, Blatt 2

KN002.08  
KN003.08

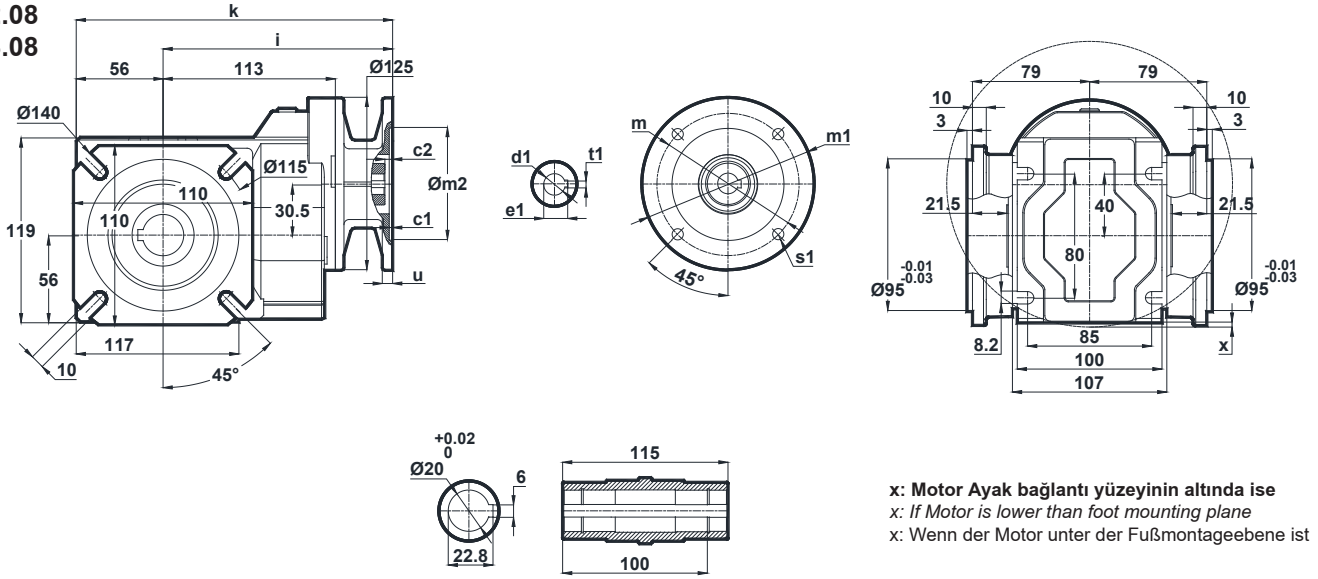

	c1	c2	s1	m	m1	m2	i	u	k	d1	t1	e1	x
63/B5	3.5	5	10	115	140	95	156	10	212	11	4	12.8	-
63/B14	2.5	5	5.5	75	90	60	60	156	10	212	11	4	-
71/B5	4	4.5	11	130	160	110	158	12	214	14	5	16.3	-
71/B14	3	4.5	7	85	105	70	70	10	214	14	5	16.3	-
80/B5	4	5	12	165	200	130	173	12	229	19	6	21.8	13.5
80/B14	4	5	7	100	120	80	80	12	229	19	6	21.8	-
90/B5	4	5	12	165	200	130	173	12	229	24	8	27.3	13.5
90/B14	4	5	9	115	140	95	95	12	229	24	8	27.3	-

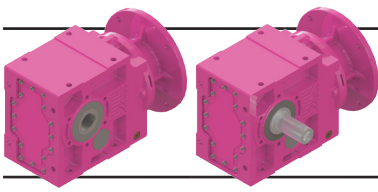

# Ölçü Sayfaları

## Dimension Pages

### Abmessungsseiten

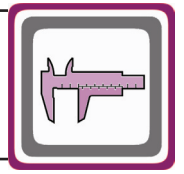

-Mil ucu çekirme deliği DIN 332 sayfa 2 / Tapped center hole to DIN 332, sheet 2 / Zentrierung mit Gewinde DIN 332, Blatt 2

KN102.00  
KN103.00

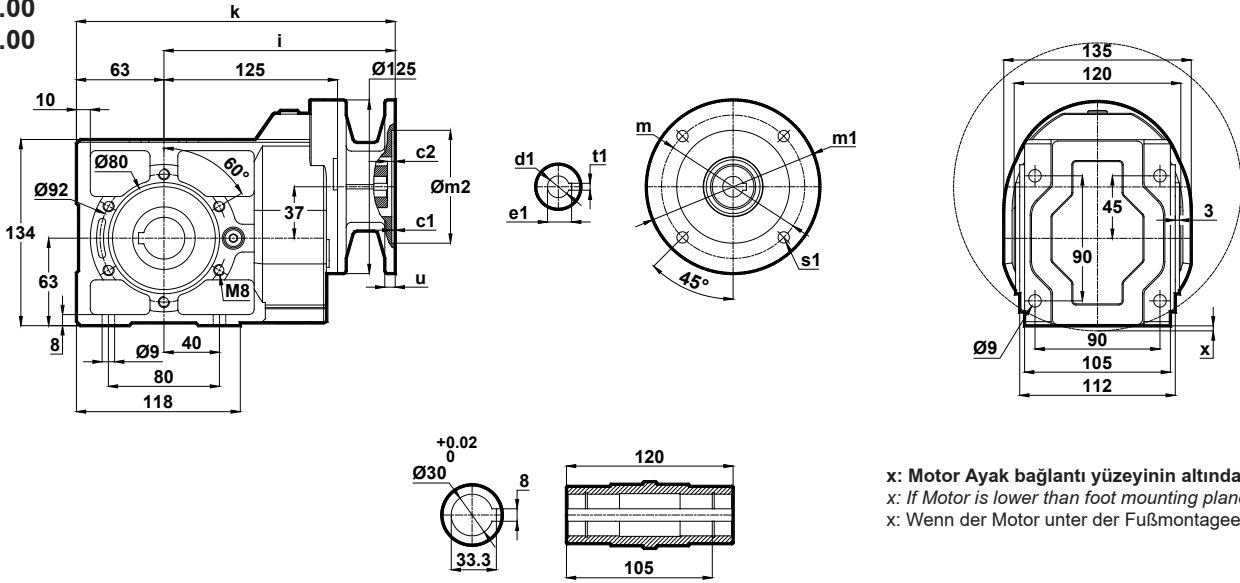

x: Motor Ayak bağlantı yüzeyinin altında ise  
x: If Motor is lower than foot mounting plane  
x: Wenn der Motor unter der Fußmontageebene ist

	c1	c2	s1	m	m1	m2	i	u	k	d1	t1	e1	x
63/B5	3.5	5	10	115	140	95	168	10	231	11	4	12.8	-
63/B14	2.5	5	5.5	75	90	60	170	12	233	14	5	16.3	-
71/B5	4	4.5	11	130	160	110	185	12	248	19	6	21.8	-
71/B14	3	4.5	7	85	105	70	185	12	248	24	8	27.3	-
80/B5	4	5	12	165	200	130	185	12	248	24	8	27.3	-
80/B14	4	4.7	7	100	120	80	185	12	248	24	8	27.3	-
90/B5	4	5	12	165	200	130	185	12	248	24	8	27.3	-
90/B14	4	4.7	9	115	140	95	185	12	248	24	8	27.3	-

KN102.01  
KN103.01

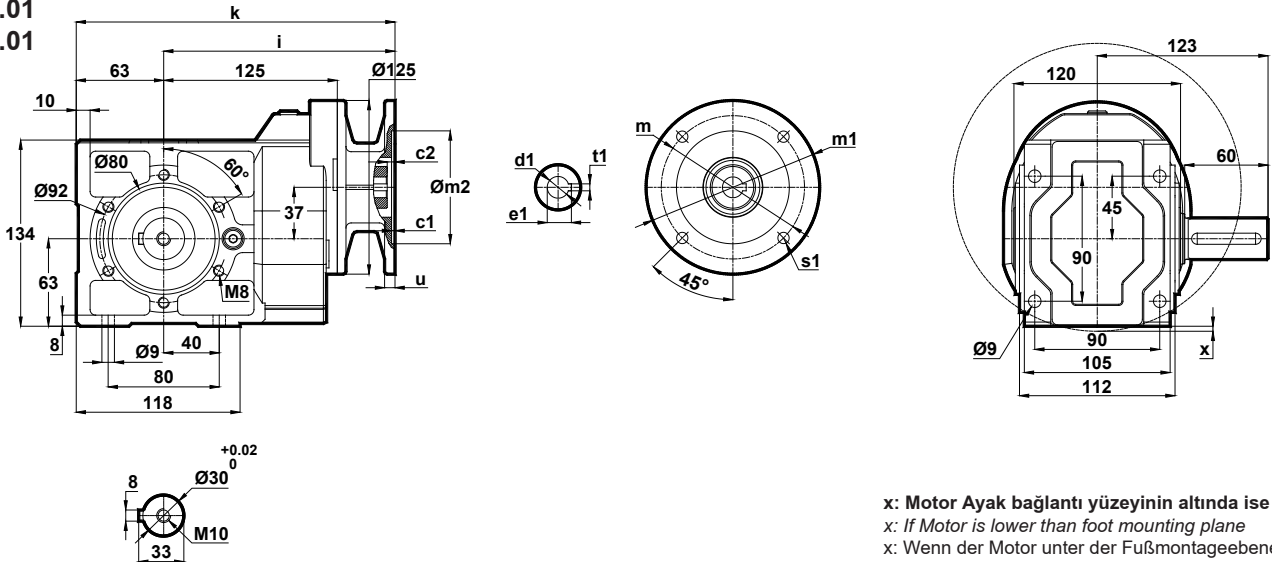

x: Motor Ayak bağlantı yüzeyinin altında ise  
x: If Motor is lower than foot mounting plane  
x: Wenn der Motor unter der Fußmontageebene ist

	c1	c2	s1	m	m1	m2	i	u	k	d1	t1	e1	x
63/B5	3.5	5	10	115	140	95	168	10	231	11	4	12.8	-
63/B14	2.5	5	5.5	75	90	60	170	12	233	14	5	16.3	-
71/B5	4	4.5	11	130	160	110	185	12	248	19	6	21.8	-
71/B14	3	4.5	7	85	105	70	185	12	248	24	8	27.3	-
80/B5	4	5	12	165	200	130	185	12	248	24	8	27.3	-
80/B14	4	4.7	7	100	120	80	185	12	248	24	8	27.3	-
90/B5	4	5	12	165	200	130	185	12	248	24	8	27.3	-
90/B14	4	4.7	9	115	140	95	185	12	248	24	8	27.3	-

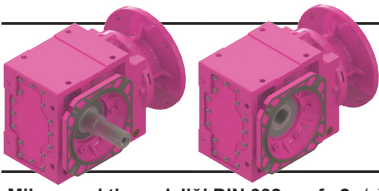

# Ölçü Sayfaları

## Dimension Pages

### Abmessungsseiten

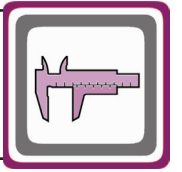

-Mil ucu çekirme deliği DIN 332 sayfa 2 / Tapped center hole to DIN 332, sheet 2 / Zentrierung mit Gewinde DIN 332, Blatt 2

KN102.02  
KN103.02

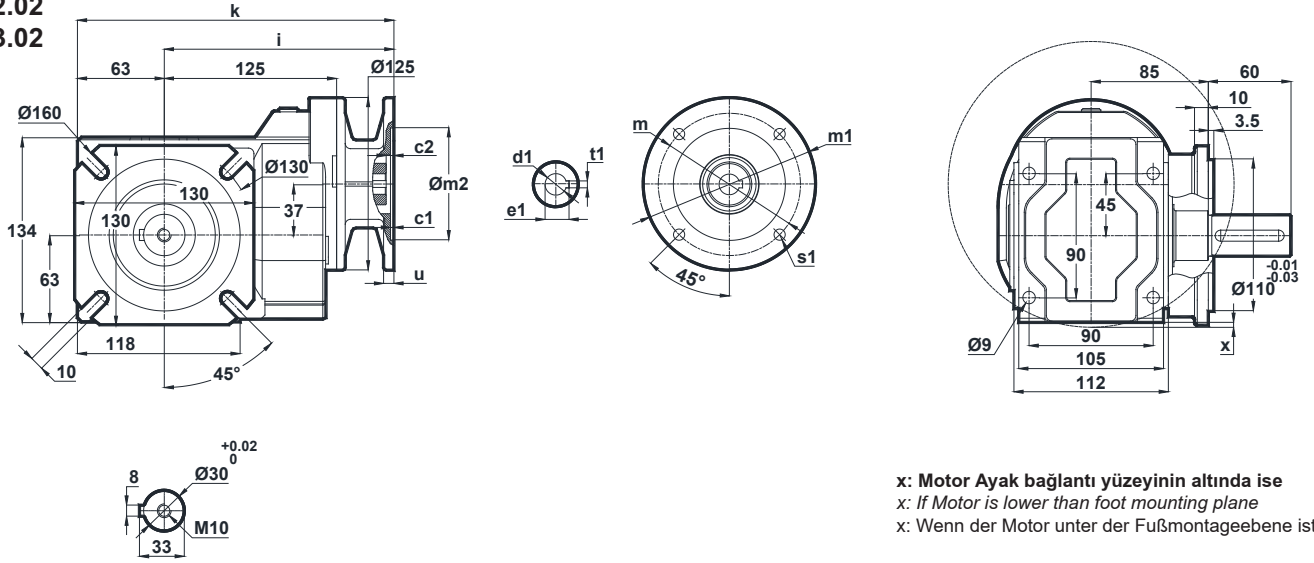

	c1	c2	s1	m	m1	m2	i	u	k	d1	t1	e1	x
63/B5	3.5	5	10	115	140	95	168	10	231	11	4	12.8	-
63/B14	2.5	5	5.5	75	90	60	60	10	231	11	4	12.8	-
71/B5	4	4.5	11	130	160	110	170	12	233	14	5	16.3	-
71/B14	3	4.5	7	85	105	70	70	10	233	14	5	16.3	-
80/B5	4	5	12	165	200	130	185	12	248	19	6	21.8	-
80/B14	4	4.7	7	100	120	80	80	12	248	19	6	21.8	-
90/B5	4	5	12	165	200	130	185	12	248	24	8	27.3	-
90/B14	4	4.7	9	115	140	95	95	12	248	24	8	27.3	-

x: Motor Ayak bağlantı yüzeyinin altında ise  
x: If Motor is lower than foot mounting plane  
x: Wenn der Motor unter der Fußmontageebene ist

KN102.03  
KN103.03

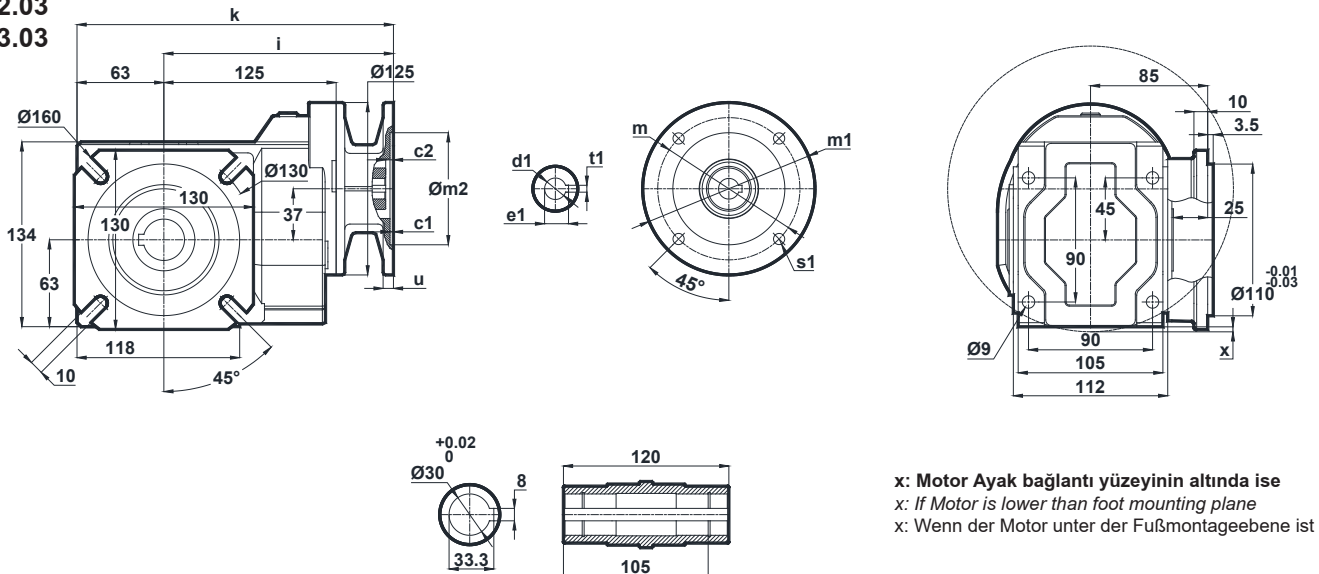

	c1	c2	s1	m	m1	m2	i	u	k	d1	t1	e1	x
63/B5	3.5	5	10	115	140	95	168	10	231	11	4	12.8	-
63/B14	2.5	5	5.5	75	90	60	60	10	231	11	4	12.8	-
71/B5	4	4.5	11	130	160	110	170	12	233	14	5	16.3	-
71/B14	3	4.5	7	85	105	70	70	10	233	14	5	16.3	-
80/B5	4	5	12	165	200	130	185	12	248	19	6	21.8	-
80/B14	4	4.7	7	100	120	80	80	12	248	19	6	21.8	-
90/B5	4	5	12	165	200	130	185	12	248	24	8	27.3	-
90/B14	4	4.7	9	115	140	95	95	12	248	24	8	27.3	-

x: Motor Ayak bağlantı yüzeyinin altında ise  
x: If Motor is lower than foot mounting plane  
x: Wenn der Motor unter der Fußmontageebene ist

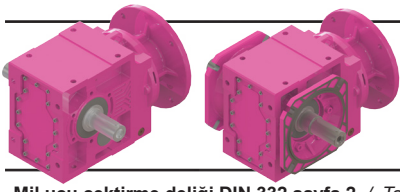

# Ölçü Sayfaları

## Dimension Pages

### Abmessungsseiten

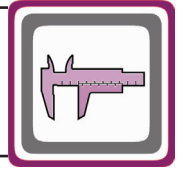

-Mil ucu çektirme deliği DIN 332 sayfa 2 / Tapped center hole to DIN 332, sheet 2 / Zentrierung mit Gewinde DIN 332, Blatt 2

KN102.04  
KN103.04

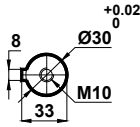
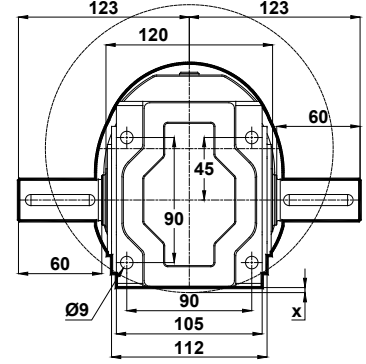
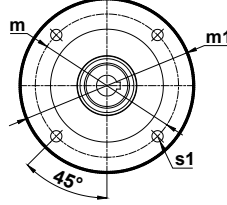
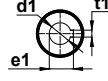
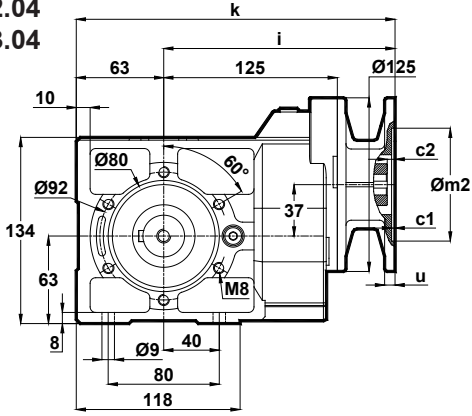

x: Motor Ayak bağlantı yüzeyinin altında ise  
x: If Motor is lower than foot mounting plane  
x: Wenn der Motor unter der Fußmontageebene ist

	c1	c2	s1	m	m1	m2	i	u	k	d1	t1	e1	x
63/B5	3.5	5	10	115	140	95	168	10	231	11	4	12.8	-
63/B14	2.5	5	5.5	75	90	60	170	12	233	14	5	16.3	-
71/B5	4	4.5	11	130	160	110	185	12	248	19	6	21.8	-
71/B14	3	4.5	7	85	105	70	185	12	248	24	8	27.3	-
80/B5	4	5	12	165	200	130	185	12	248	24	8	27.3	-
80/B14	4	4.7	7	100	120	80	185	12	248	24	8	27.3	-
90/B5	4	5	12	165	200	130	185	12	248	24	8	27.3	-
90/B14	4	4.7	9	115	140	95	185	12	248	24	8	27.3	-

KN102.05  
KN103.05

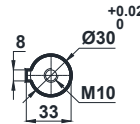
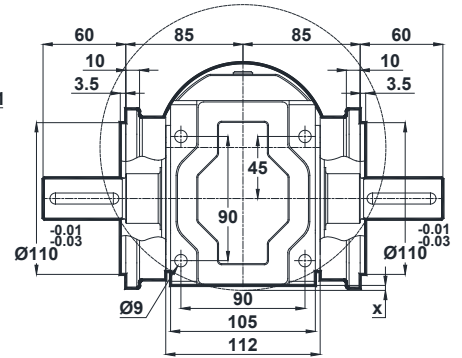
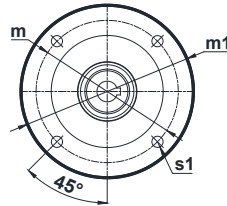
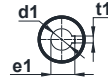
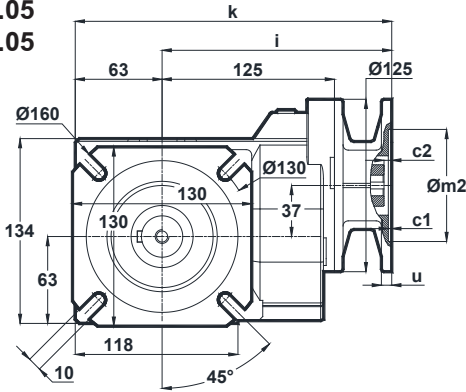

x: Motor Ayak bağlantı yüzeyinin altında ise  
x: If Motor is lower than foot mounting plane  
x: Wenn der Motor unter der Fußmontageebene ist

	c1	c2	s1	m	m1	m2	i	u	k	d1	t1	e1	x
63/B5	3.5	5	10	115	140	95	168	10	231	11	4	12.8	-
63/B14	2.5	5	5.5	75	90	60	170	12	233	14	5	16.3	-
71/B5	4	4.5	11	130	160	110	185	12	248	19	6	21.8	-
71/B14	3	4.5	7	85	105	70	185	12	248	24	8	27.3	-
80/B5	4	5	12	165	200	130	185	12	248	24	8	27.3	-
80/B14	4	4.7	7	100	120	80	185	12	248	24	8	27.3	-
90/B5	4	5	12	165	200	130	185	12	248	24	8	27.3	-
90/B14	4	4.7	9	115	140	95	185	12	248	24	8	27.3	-



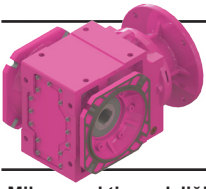

# Ölçü Sayfaları Dimension Pages Abmessungsseiten

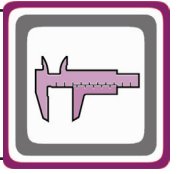

-Mil ucu çekirme deliği DIN 332 sayfa 2 / Tapped center hole to DIN 332, sheet 2 / Zentrierung mit Gewinde DIN 332, Blatt 2

KN102.08  
KN103.08

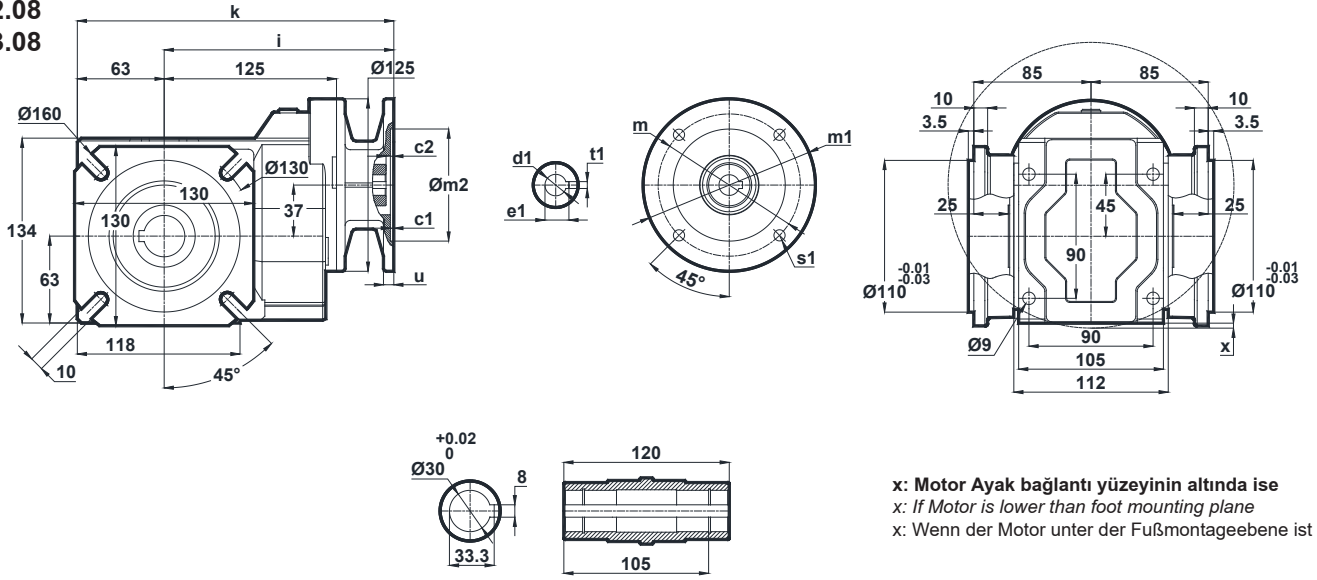

x: Motor Ayak bağlantı yüzeyinin altında ise  
x: If Motor is lower than foot mounting plane  
x: Wenn der Motor unter der Fußmontageebene ist

	c1	c2	s1	m	m1	m2	i	u	k	d1	t1	e1	x
63/B5	3.5	5	10	115	140	95	168	10	231	11	4	12.8	-
63/B14	2.5	5	5.5	75	90	60	60	10	231	11	4	12.8	-
71/B5	4	4.5	11	130	160	110	170	12	233	14	5	16.3	-
71/B14	3	4.5	7	85	105	70	70	10	233	14	5	16.3	-
80/B5	4	5	12	165	200	130	185	12	248	19	6	21.8	-
80/B14	4	4.7	7	100	120	80	80	12	248	19	6	21.8	-
90/B5	4	5	12	165	200	130	185	12	248	24	8	27.3	-
90/B14	4	4.7	9	115	140	95	95	12	248	24	8	27.3	-

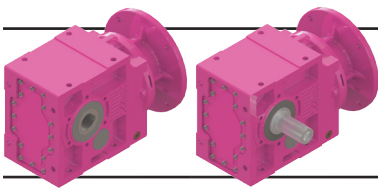

# Ölçü Sayfaları

## Dimension Pages

### Abmessungsseiten

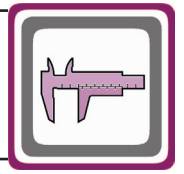

-Mil ucu çektirme deliği DIN 332 sayfa 2 / Tapped center hole to DIN 332, sheet 2 / Zentrierung mit Gewinde DIN 332, Blatt 2

KN202.00  
KN203.00

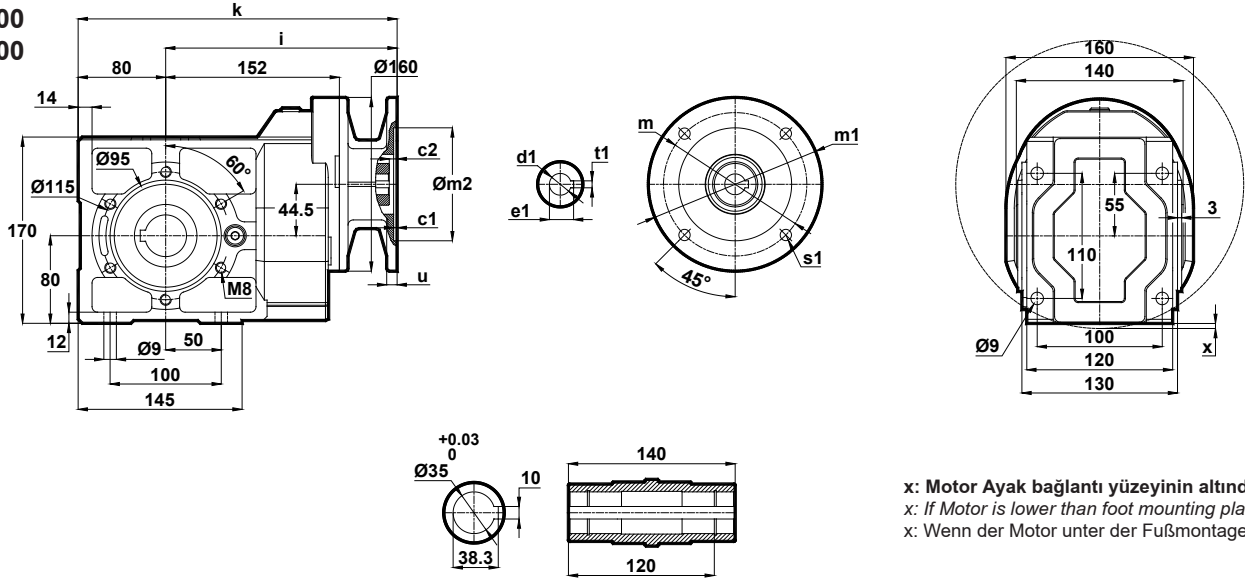

x: Motor Ayak bağlantı yüzeyinin altında ise  
x: If Motor is lower than foot mounting plane  
x: Wenn der Motor unter der Fußmontageebene ist

	c1	c2	s1	m	m1	m2	i	u	k	d1	t1	e1	x
63/B5	3.5	8	9	115	140	95	226	12	306	11	4	12.8	-
71/B5 71/B14	4 3	8.5	11 7	130 85	160 105	110 70	197	12 10	277	14	5	16.3	-
80/B5 80/B14	4	5	12 7	165 100	200 120	130 80	226	12	306	19	6	21.8	-
90/B5 90/B14	4	5	12 9	165 115	200 140	130 95	226	12	306	24	8	27.3	-
100/B5 100/B14	4.5 3.5	5.5	15 9	215 130	250 160	180 110	219	12	299	28	8	31.3	0.5 -
112/B5 112/B14	4.5 3.5	5.5	15 9	215 130	250 160	180 110	219	12	299	28	8	31.3	0.5 -

KN202.01  
KN203.01

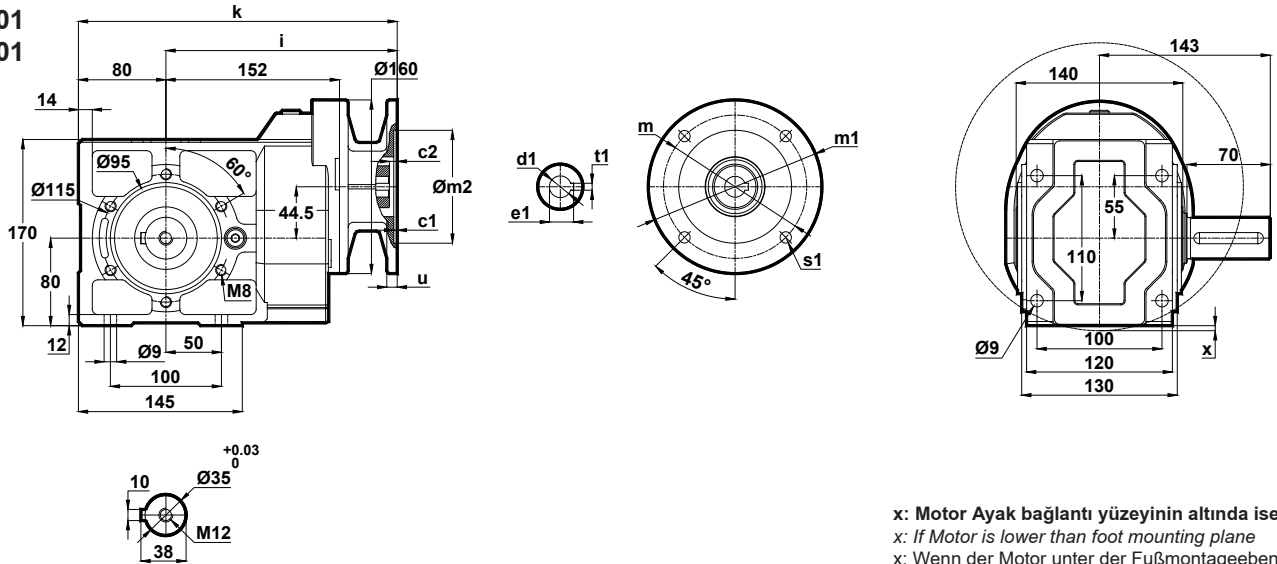

x: Motor Ayak bağlantı yüzeyinin altında ise  
x: If Motor is lower than foot mounting plane  
x: Wenn der Motor unter der Fußmontageebene ist

	c1	c2	s1	m	m1	m2	i	u	k	d1	t1	e1	x
63/B5	3.5	8	9	115	140	95	226	12	306	11	4	12.8	-
71/B5 71/B14	4 3	8.5	11 7	130 85	160 105	110 70	197	12 10	277	14	5	16.3	-
80/B5 80/B14	4	5	12 7	165 100	200 120	130 80	226	12	306	19	6	21.8	-
90/B5 90/B14	4	5	12 9	165 115	200 140	130 95	226	12	306	24	8	27.3	-
100/B5 100/B14	4.5 3.5	5.5	15 9	215 130	250 160	180 110	219	12	299	28	8	31.3	0.5 -
112/B5 112/B14	4.5 3.5	5.5	15 9	215 130	250 160	180 110	219	12	299	28	8	31.3	0.5 -

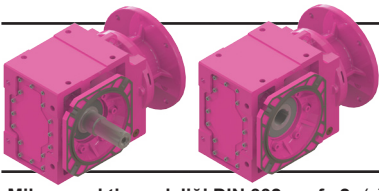

# Ölçü Sayfaları

## Dimension Pages

### Abmessungsseiten

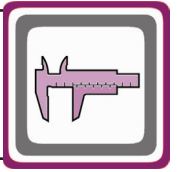

-Mil ucu çekirme deliği DIN 332 sayfa 2 / Tapped center hole to DIN 332, sheet 2 / Zentrierung mit Gewinde DIN 332, Blatt 2

KN202.02  
KN203.02

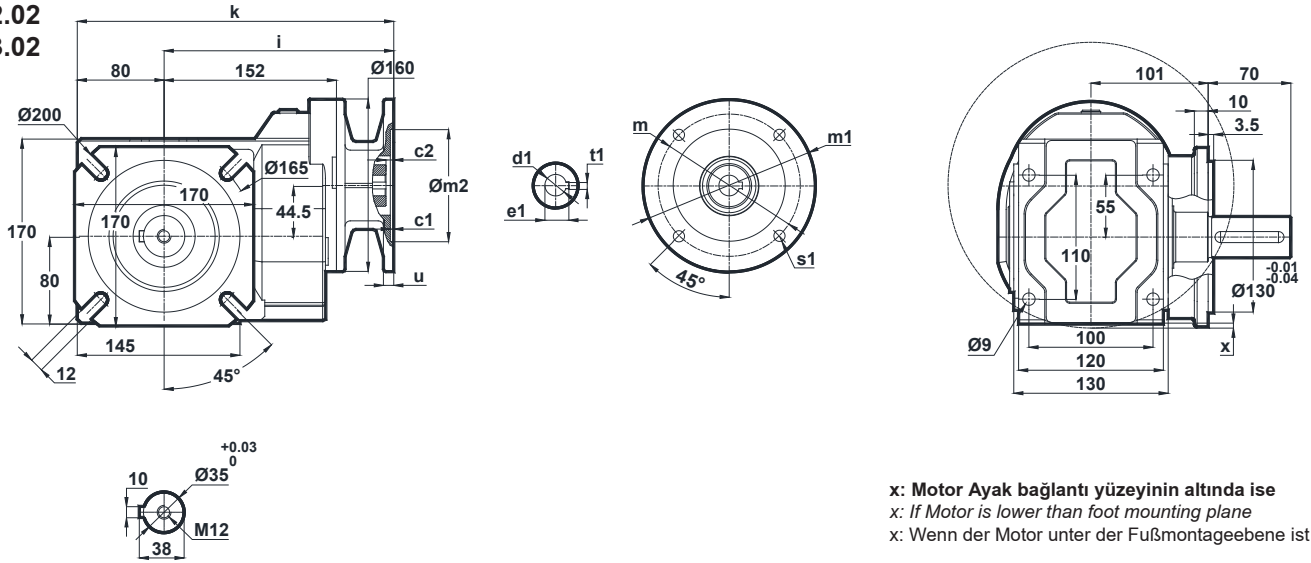

	c1	c2	s1	m	m1	m2	i	u	k	d1	t1	e1	x
63/B5	3.5	8	9	115	140	95	226	12	306	11	4	12.8	-
71/B5	4	8.5	11	130	160	110	197	12	277	14	5	16.3	-
71/B14	3		7	85	105	70		10					
80/B5	4	5	12	165	200	130	226	12	306	19	6	21.8	-
80/B14			7	100	120	80							
90/B5	4	5	12	165	200	130	226	12	306	24	8	27.3	-
90/B14			9	115	140	95							
100/B5	4.5	5.5	15	215	250	180	219	12	299	28	8	31.3	0.5
100/B14	3.5		9	130	160	110							-
112/B5	4.5	5.5	15	215	250	180	219	12	299	28	8	31.3	0.5
112/B14	3.5		9	130	160	110							-

KN202.03  
KN203.03

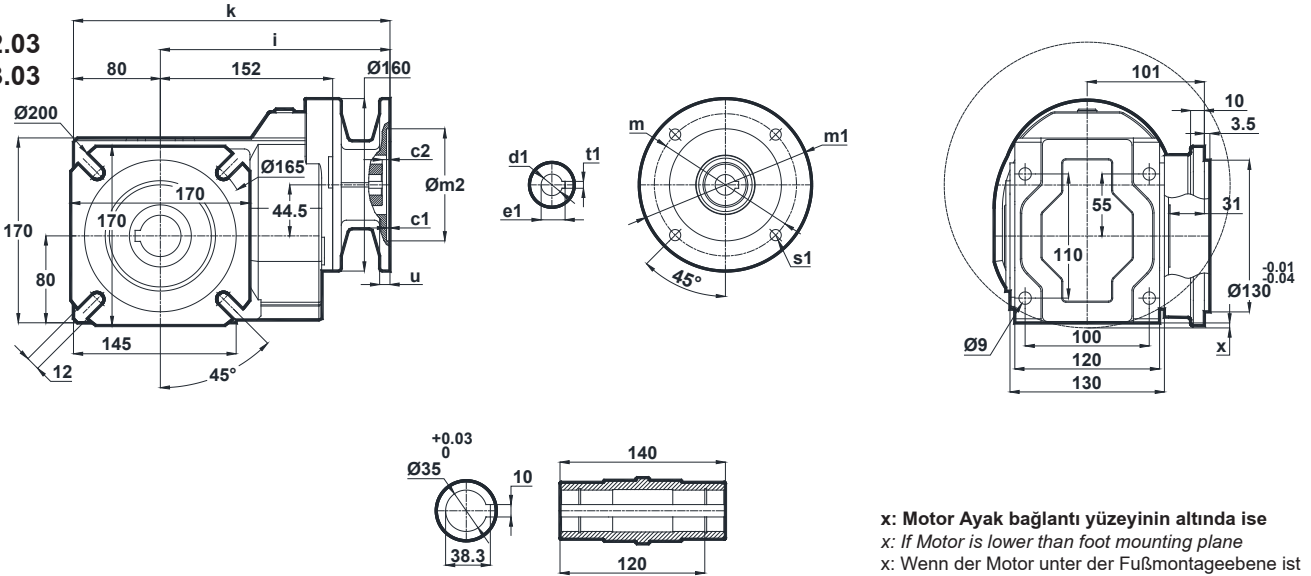

	c1	c2	s1	m	m1	m2	i	u	k	d1	t1	e1	x
63/B5	3.5	8	9	115	140	95	226	12	306	11	4	12.8	-
71/B5	4	8.5	11	130	160	110	197	12	277	14	5	16.3	-
71/B14	3		7	85	105	70		10					
80/B5	4	5	12	165	200	130	226	12	306	19	6	21.8	-
80/B14			7	100	120	80							
90/B5	4	5	12	165	200	130	226	12	306	24	8	27.3	-
90/B14			9	115	140	95							
100/B5	4.5	5.5	15	215	250	180	219	12	299	28	8	31.3	0.5
100/B14	3.5		9	130	160	110							-
112/B5	4.5	5.5	15	215	250	180	219	12	299	28	8	31.3	0.5
112/B14	3.5		9	130	160	110							-

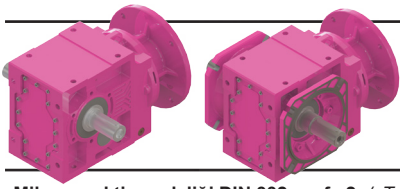

# Ölçü Sayfaları

## Dimension Pages

### Abmessungsseiten

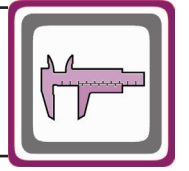

-Mil ucu çekirme deliği DIN 332 sayfa 2 / Tapped center hole to DIN 332, sheet 2 / Zentrierung mit Gewinde DIN 332, Blatt 2

KN202.04  
KN203.04

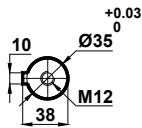
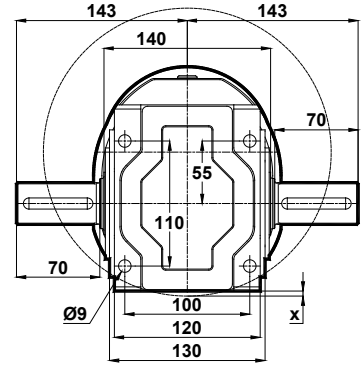
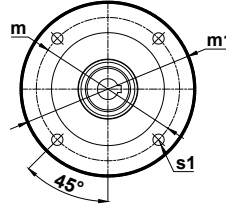
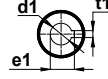
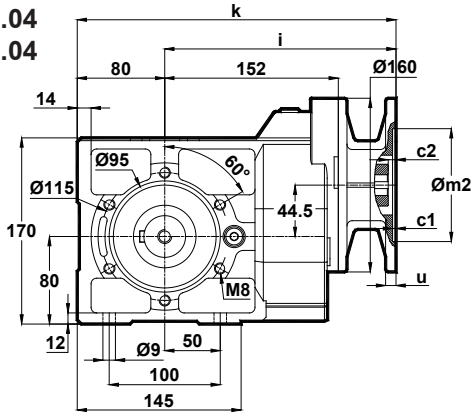

x: Motor Ayak bağlantı yüzeyinin altında ise  
x: If Motor is lower than foot mounting plane  
x: Wenn der Motor unter der Fußmontageebene ist

	c1	c2	s1	m	m1	m2	i	u	k	d1	t1	e1	x
63/B5	3.5	8	9	115	140	95	226	12	306	11	4	12.8	-
71/B5	4	8.5	11	130	160	110	197	12	277	14	5	16.3	-
71/B14	3	8.5	7	85	105	70	197	10	277	14	5	16.3	-
80/B5	4	5	12	165	200	130	226	12	306	19	6	21.8	-
80/B14	4	5	7	100	120	80	226	12	306	19	6	21.8	-
90/B5	4	5	12	165	200	130	226	12	306	24	8	27.3	-
90/B14	4	5	9	115	140	95	226	12	306	24	8	27.3	-
100/B5	4.5	5.5	15	215	250	180	219	12	299	28	8	31.3	0.5
100/B14	3.5	5.5	9	130	160	110	219	12	299	28	8	31.3	-
112/B5	4.5	5.5	15	215	250	180	219	12	299	28	8	31.3	0.5
112/B14	3.5	5.5	9	130	160	110	219	12	299	28	8	31.3	-

KN202.05  
KN203.05

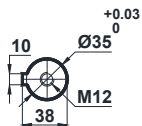
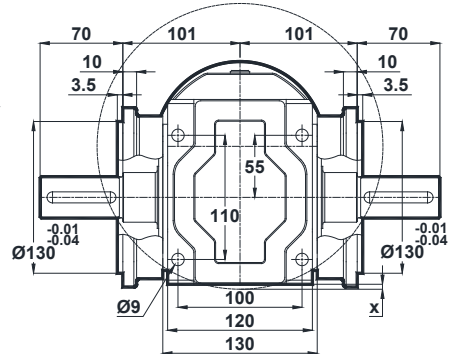
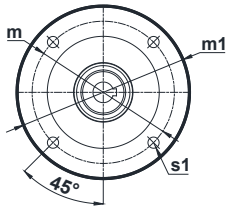
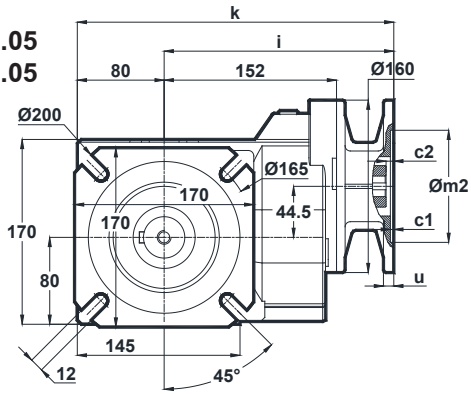

x: Motor Ayak bağlantı yüzeyinin altında ise  
x: If Motor is lower than foot mounting plane  
x: Wenn der Motor unter der Fußmontageebene ist

	c1	c2	s1	m	m1	m2	i	u	k	d1	t1	e1	x
63/B5	3.5	8	9	115	140	95	226	12	306	11	4	12.8	-
71/B5	4	8.5	11	130	160	110	197	12	277	14	5	16.3	-
71/B14	3	8.5	7	85	105	70	197	10	277	14	5	16.3	-
80/B5	4	5	12	165	200	130	226	12	306	19	6	21.8	-
80/B14	4	5	7	100	120	80	226	12	306	19	6	21.8	-
90/B5	4	5	12	165	200	130	226	12	306	24	8	27.3	-
90/B14	4	5	9	115	140	95	226	12	306	24	8	27.3	-
100/B5	4.5	5.5	15	215	250	180	219	12	299	28	8	31.3	0.5
100/B14	3.5	5.5	9	130	160	110	219	12	299	28	8	31.3	-
112/B5	4.5	5.5	15	215	250	180	219	12	299	28	8	31.3	0.5
112/B14	3.5	5.5	9	130	160	110	219	12	299	28	8	31.3	-

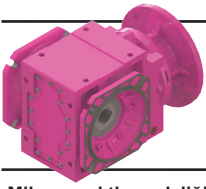

# Ölçü Sayfaları

## Dimension Pages

### Abmessungsseiten

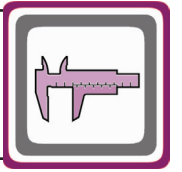

-Mil ucu çekirme deliği DIN 332 sayfa 2 / Tapped center hole to DIN 332, sheet 2 / Zentrierung mit Gewinde DIN 332, Blatt 2

KN202.08  
KN203.08

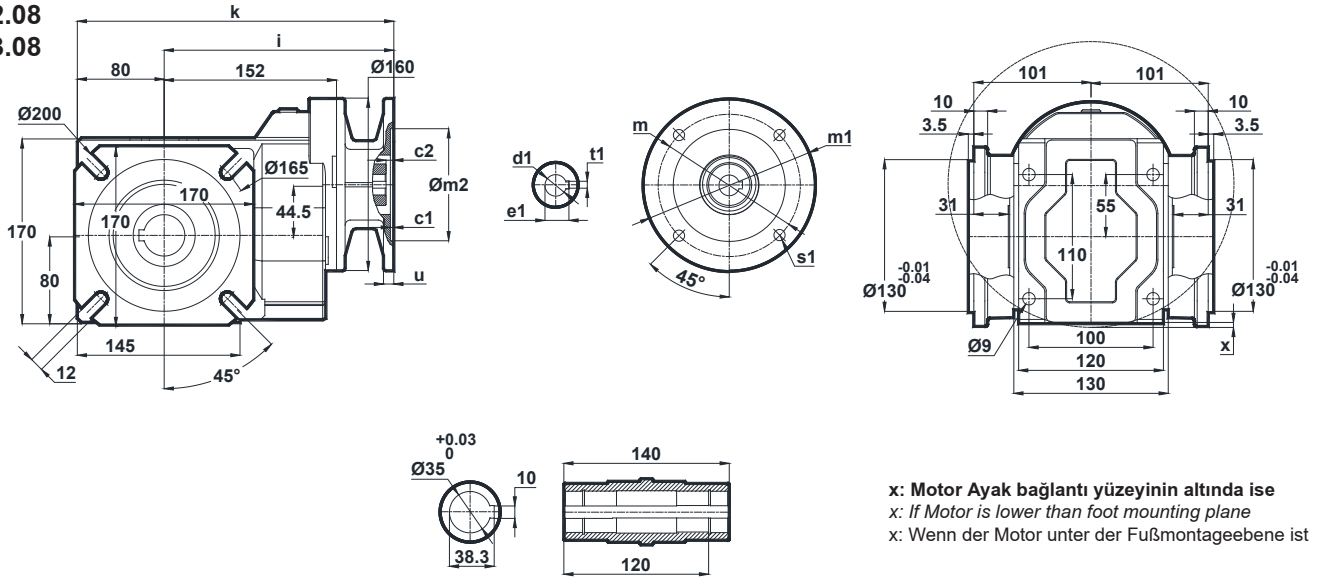

x: Motor Ayak bağlantı yüzeyinin altında ise  
x: If Motor is lower than foot mounting plane  
x: Wenn der Motor unter der Fußmontageebene ist

	c1	c2	s1	m	m1	m2	i	u	k	d1	t1	e1	x
63/B5	3.5	8	9	115	140	95	226	12	306	11	4	12.8	-
71/B5	4	8.5	11	130	160	110	197	12	277	14	5	16.3	-
71/B14	3		7	85	105	70		10					
80/B5	4	5	12	165	200	130	226	12	306	19	6	21.8	-
80/B14			7	100	120	80							
90/B5	4	5	12	165	200	130	226	12	306	24	8	27.3	-
90/B14			9	115	140	95							
100/B5	4.5	5.5	15	215	250	180	219	12	299	28	8	31.3	0.5
100/B14	3.5		9	130	160	110							-
112/B5	4.5	5.5	15	215	250	180	219	12	299	28	8	31.3	0.5
112/B14	3.5		9	130	160	110							-

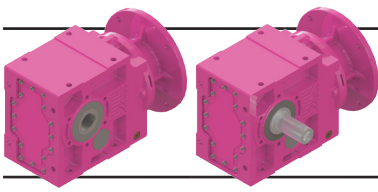

# Ölçü Sayfaları

## Dimension Pages

### Abmessungsseiten

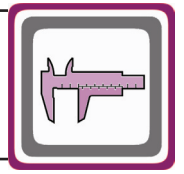

-Mil ucu çekirme deliği DIN 332 sayfa 2 / Tapped center hole to DIN 332, sheet 2 / Zentrierung mit Gewinde DIN 332, Blatt 2

#### KN273.00

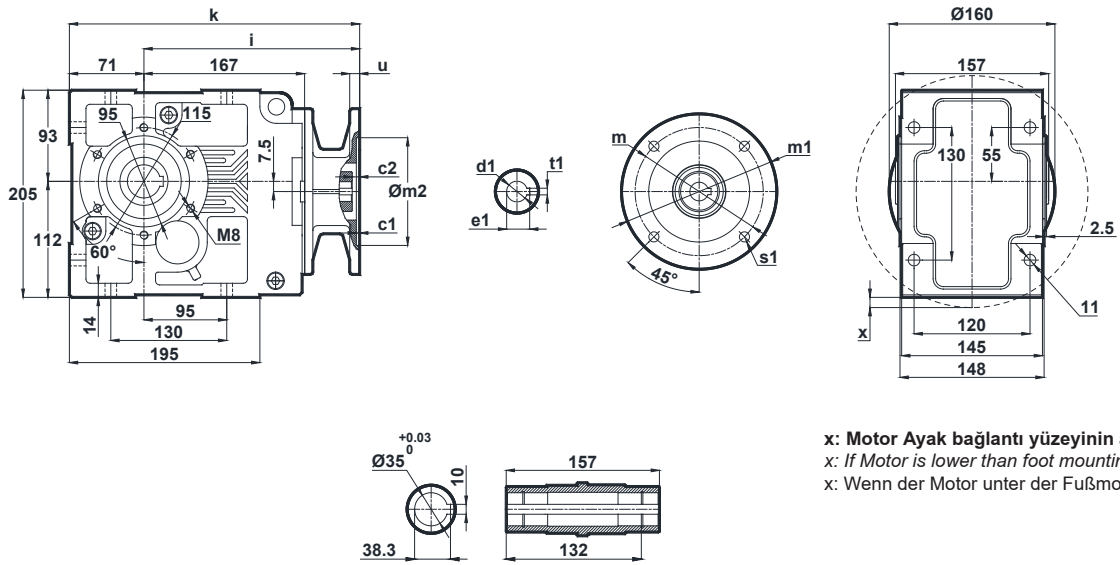

x: Motor Ayak bağlantı yüzeyinin altında ise  
x: If Motor is lower than foot mounting plane  
x: Wenn der Motor unter der Fußmontageebene ist

	c1	c2	s1	m	m1	m2	i	u	k	d1	t1	e1	x
63/B5	3.5	8	9	115	140	95	241	12	312	11	4	12.8	-
71/B5	4	8.5	11	130	160	110	212	12	283	14	5	16.3	-
71/B14	3		7	85	105	70		10					
80/B5	4	5	12	165	200	130	241	12	312	19	6	21.8	-
80/B14			7	100	120	80							
90/B5	4	5	12	165	200	130	241	12	312	24	8	27.3	-
90/B14			9	115	140	95							
100/B5	4.5	5.5	15	215	250	180	234	12	305	28	8	31.3	20.5
100/B14	3.5		9	130	160	110							-
112/B5	4.5	5.5	15	215	250	180	234	12	305	28	8	31.3	20.5
112/B14	3.5		9	130	160	110							-

#### KN273.01

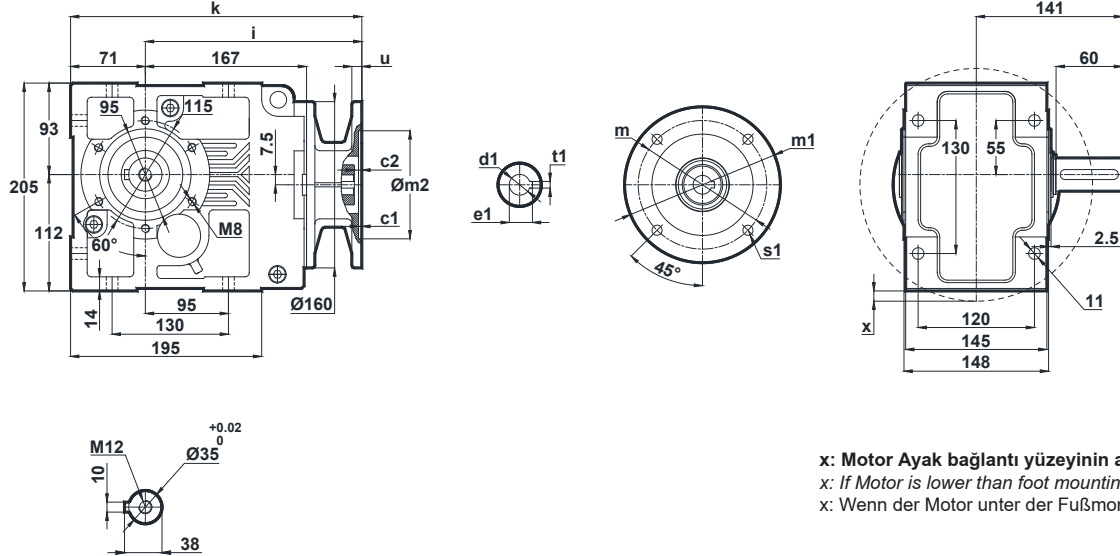

x: Motor Ayak bağlantı yüzeyinin altında ise  
x: If Motor is lower than foot mounting plane  
x: Wenn der Motor unter der Fußmontageebene ist

	c1	c2	s1	m	m1	m2	i	u	k	d1	t1	e1	x
63/B5	3.5	8	9	115	140	95	241	12	312	11	4	12.8	-
71/B5	4	8.5	11	130	160	110	212	12	283	14	5	16.3	-
71/B14	3		7	85	105	70		10					
80/B5	4	5	12	165	200	130	241	12	312	19	6	21.8	-
80/B14			7	100	120	80							
90/B5	4	5	12	165	200	130	241	12	312	24	8	27.3	-
90/B14			9	115	140	95							
100/B5	4.5	5.5	15	215	250	180	234	12	305	28	8	31.3	20.5
100/B14	3.5		9	130	160	110							-
112/B5	4.5	5.5	15	215	250	180	234	12	305	28	8	31.3	20.5
112/B14	3.5		9	130	160	110							-

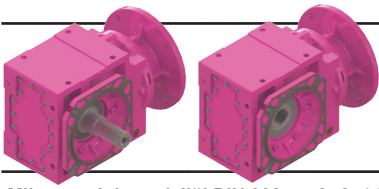

# Ölçü Sayfaları

## Dimension Pages

### Abmessungsseiten

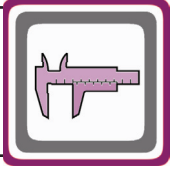

-Mil ucu çekirme deliği DIN 332 sayfa 2 / Tapped center hole to DIN 332, sheet 2 / Zentrierung mit Gewinde DIN 332, Blatt 2

#### KN273.02

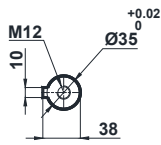
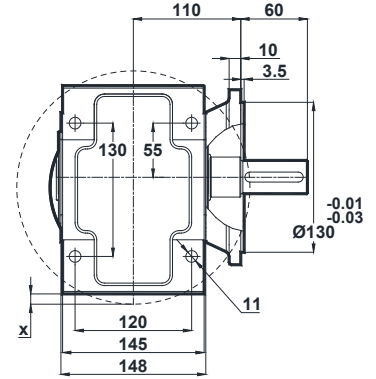
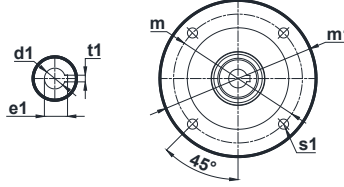
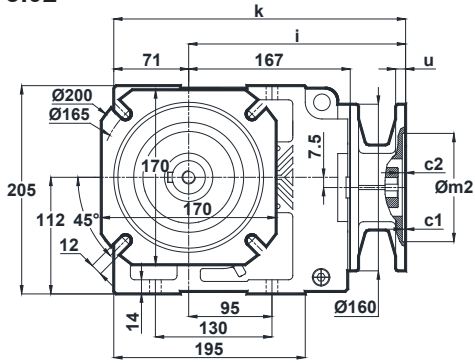

x: Motor Ayak bağlantı yüzeyinin altında ise  
x: If Motor is lower than foot mounting plane  
x: Wenn der Motor unter der Fußmontageebene ist

	c1	c2	s1	m	m1	m2	i	u	k	d1	t1	e1	x
63/B5	3.5	8	9	115	140	95	241	12	312	11	4	12.8	-
71/B5	4	8.5	11	130	160	110	212	12	283	14	5	16.3	-
71/B14	3		7	85	105	70		10					
80/B5	4	5	12	165	200	130	241	12	312	19	6	21.8	-
80/B14			7	100	120	80							
90/B5	4	5	12	165	200	130	241	12	312	24	8	27.3	-
90/B14			9	115	140	95							
100/B5	4.5	5.5	15	215	250	180	234	12	305	28	8	31.3	20.5
100/B14	3.5		9	130	160	110							-
112/B5	4.5	5.5	15	215	250	180	234	12	305	28	8	31.3	20.5
112/B14	3.5		9	130	160	110							-

#### KN273.03

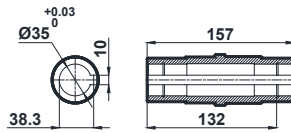
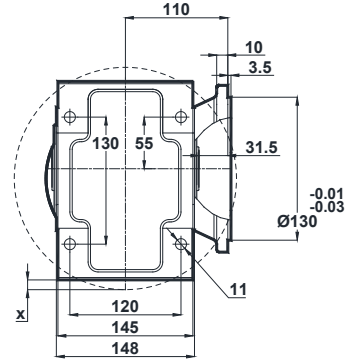
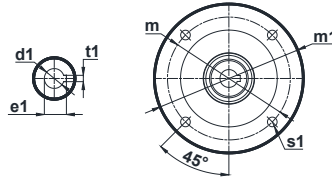
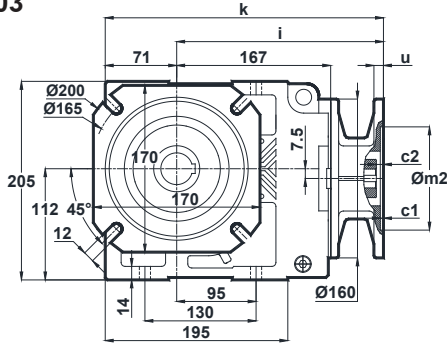

x: Motor Ayak bağlantı yüzeyinin altında ise  
x: If Motor is lower than foot mounting plane  
x: Wenn der Motor unter der Fußmontageebene ist

	c1	c2	s1	m	m1	m2	i	u	k	d1	t1	e1	x
63/B5	3.5	8	9	115	140	95	241	12	312	11	4	12.8	-
71/B5	4	8.5	11	130	160	110	212	12	283	14	5	16.3	-
71/B14	3		7	85	105	70		10					
80/B5	4	5	12	165	200	130	241	12	312	19	6	21.8	-
80/B14			7	100	120	80							
90/B5	4	5	12	165	200	130	241	12	312	24	8	27.3	-
90/B14			9	115	140	95							
100/B5	4.5	5.5	15	215	250	180	234	12	305	28	8	31.3	20.5
100/B14	3.5		9	130	160	110							-
112/B5	4.5	5.5	15	215	250	180	234	12	305	28	8	31.3	20.5
112/B14	3.5		9	130	160	110							-

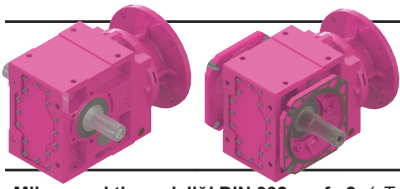

# Ölçü Sayfaları

## Dimension Pages

### Abmessungsseiten

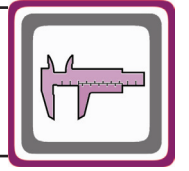

-Mil ucu çektirme deliği DIN 332 sayfa 2 / Tapped center hole to DIN 332, sheet 2 / Zentrierung mit Gewinde DIN 332, Blatt 2

#### KN273.04

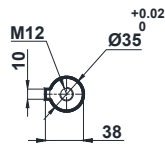
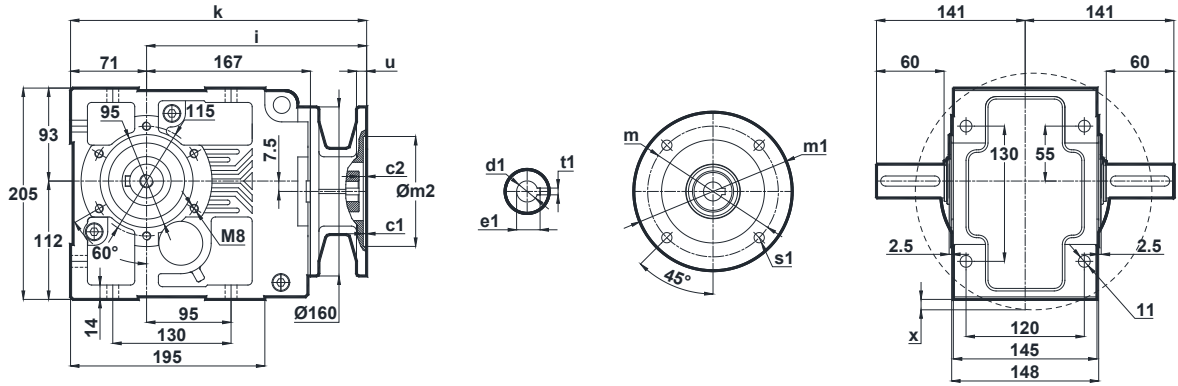

**x: Motor Ayak bağlantı yüzeyinin altında ise**  
*x: If Motor is lower than foot mounting plane*  
*x: Wenn der Motor unter der Fußmontageebene ist*

	c1	c2	s1	m	m1	m2	i	u	k	d1	t1	e1	x
63/B5	3.5	8	9	115	140	95	241	12	312	11	4	12.8	-
71/B5	4	8.5	11	130	160	110	212	12	283	14	5	16.3	-
71/B14	3	8.5	7	85	105	70	212	10	283	14	5	16.3	-
80/B5	4	5	12	165	200	130	241	12	312	19	6	21.8	-
80/B14	4	5	7	100	120	80	241	12	312	19	6	21.8	-
90/B5	4	5	12	165	200	130	241	12	312	24	8	27.3	-
90/B14	4	5	9	115	140	95	241	12	312	24	8	27.3	-
100/B5	4.5	5.5	15	215	250	180	234	12	305	28	8	31.3	20.5
100/B14	3.5	5.5	9	130	160	110	234	12	305	28	8	31.3	-
112/B5	4.5	5.5	15	215	250	180	234	12	305	28	8	31.3	20.5
112/B14	3.5	5.5	9	130	160	110	234	12	305	28	8	31.3	-

#### KN273.05

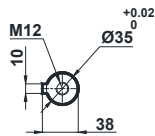
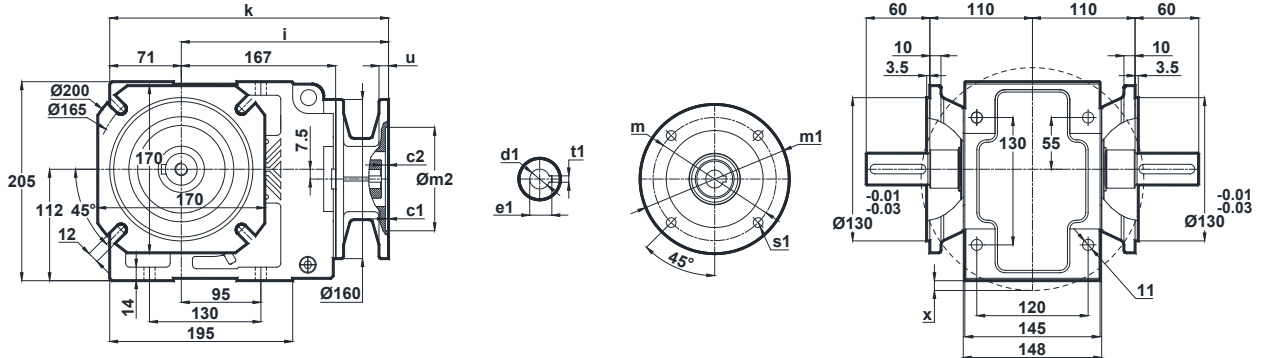

**x: Motor Ayak bağlantı yüzeyinin altında ise**  
*x: If Motor is lower than foot mounting plane*  
*x: Wenn der Motor unter der Fußmontageebene ist*

	c1	c2	s1	m	m1	m2	i	u	k	d1	t1	e1	x
63/B5	3.5	8	9	115	140	95	241	12	312	11	4	12.8	-
71/B5	4	8.5	11	130	160	110	212	12	283	14	5	16.3	-
71/B14	3	8.5	7	85	105	70	212	10	283	14	5	16.3	-
80/B5	4	5	12	165	200	130	241	12	312	19	6	21.8	-
80/B14	4	5	7	100	120	80	241	12	312	19	6	21.8	-
90/B5	4	5	12	165	200	130	241	12	312	24	8	27.3	-
90/B14	4	5	9	115	140	95	241	12	312	24	8	27.3	-
100/B5	4.5	5.5	15	215	250	180	234	12	305	28	8	31.3	20.5
100/B14	3.5	5.5	9	130	160	110	234	12	305	28	8	31.3	-
112/B5	4.5	5.5	15	215	250	180	234	12	305	28	8	31.3	20.5
112/B14	3.5	5.5	9	130	160	110	234	12	305	28	8	31.3	-



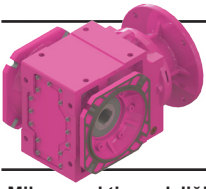

# Ölçü Sayfaları Dimension Pages Abmessungenseiten

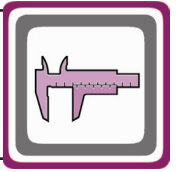

-Mil ucu çekirme deliği DIN 332 sayfa 2 / Tapped center hole to DIN 332, sheet 2 / Zentrierung mit Gewinde DIN 332, Blatt 2

KN273.08

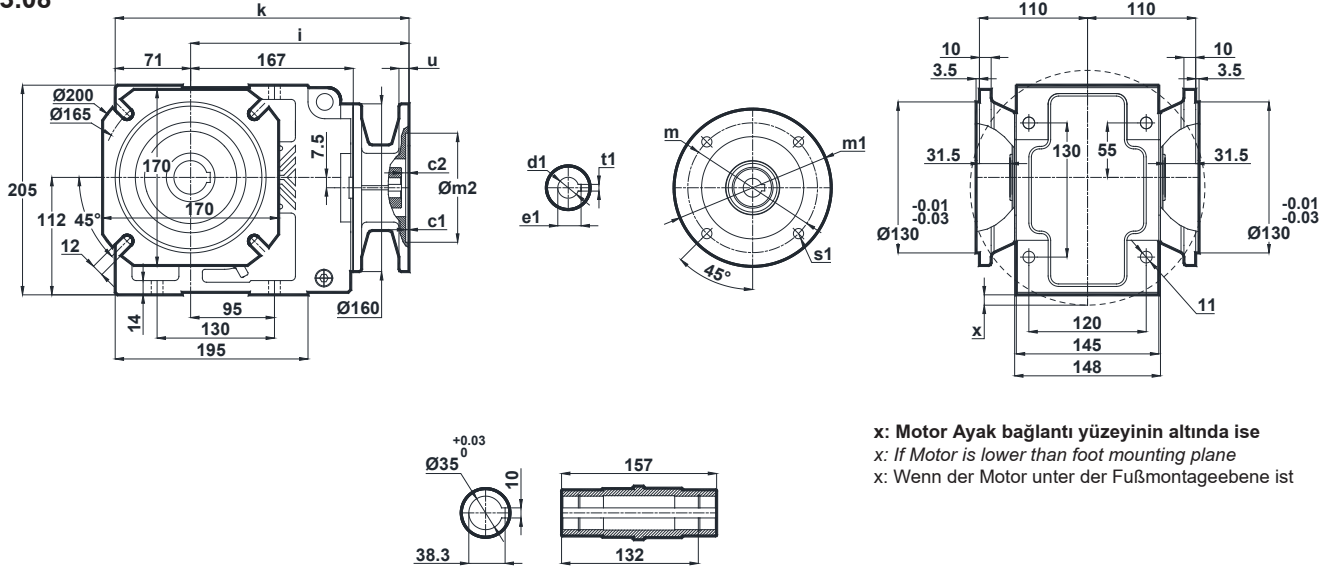

x: Motor Ayak bağlantı yüzeyinin altında ise  
x: If Motor is lower than foot mounting plane  
x: Wenn der Motor unter der Fußmontageebene ist

	c1	c2	s1	m	m1	m2	i	u	k	d1	t1	e1	x
63/B5	3.5	8	9	115	140	95	241	12	312	11	4	12.8	-
71/B5	4	8.5	11	130	160	110	212	12	283	14	5	16.3	-
71/B14	3	7	8.5	85	105	70	212	10	283	14	5	16.3	-
80/B5	4	5	12	165	200	130	241	12	312	19	6	21.8	-
80/B14	4	7	12	100	120	80	241	12	312	19	6	21.8	-
90/B5	4	5	12	165	200	130	241	12	312	24	8	27.3	-
90//B5	4	9	12	115	140	95	241	12	312	24	8	27.3	-
100/B5	4.5	5.5	15	215	250	180	234	12	305	28	8	31.3	20.5
100/B14	3.5	9	15	130	160	110	234	12	305	28	8	31.3	-
112/B5	4.5	5.5	15	215	250	180	234	12	305	28	8	31.3	20.5
112/B14	3.5	9	15	130	160	110	234	12	305	28	8	31.3	-

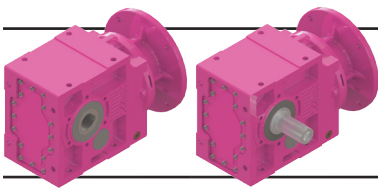

# Ölçü Sayfaları

## Dimension Pages

### Abmessungsseiten

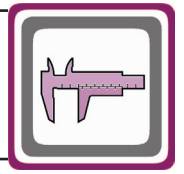

-Mil ucu çekirme deliği DIN 332 sayfa 2 / Tapped center hole to DIN 332, sheet 2 / Zentrierung mit Gewinde DIN 332, Blatt 2

KN275.00  
KN276.00

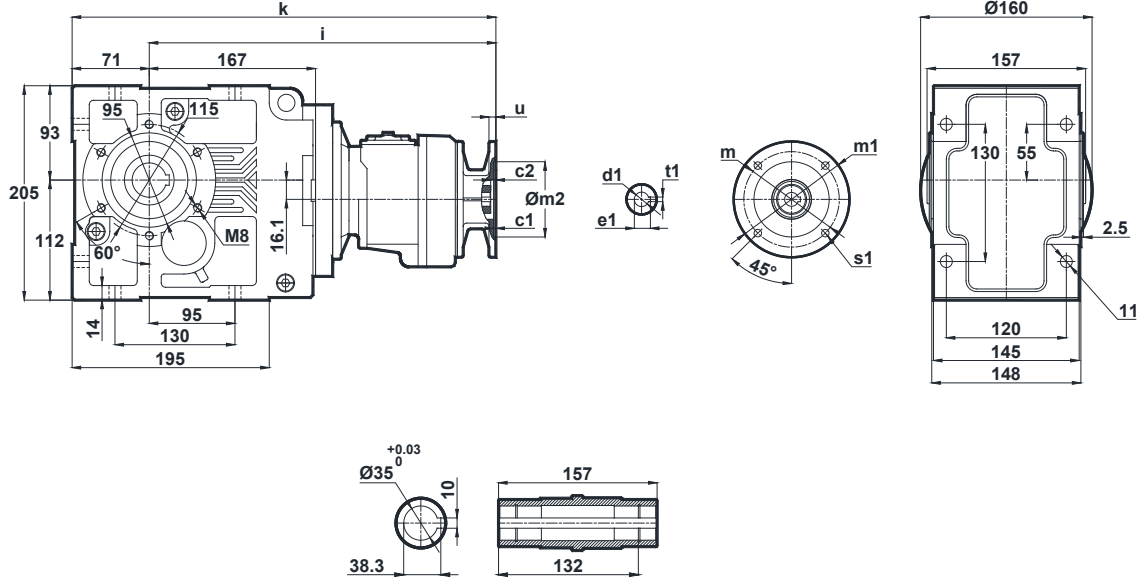

	c1	c2	s1	m	m1	m2	i	u	k	d1	t1	e1
63/B5	3.5	5	10	115	140	95	356	10	427	11	4	12.8
63/B14	2.5	5	5.5	75	90	60	356	10	427	11	4	12.8
71/B5	4	4.5	11	130	160	110	358	12	429	14	5	16.3
71/B14	3	4.5	7	85	105	70	358	10	429	14	5	16.3
80/B5	4	5	12	165	200	130	373	12	444	19	6	21.8
80/B14	4	5	7	100	120	80	373	12	444	19	6	21.8

KN275.01  
KN276.01

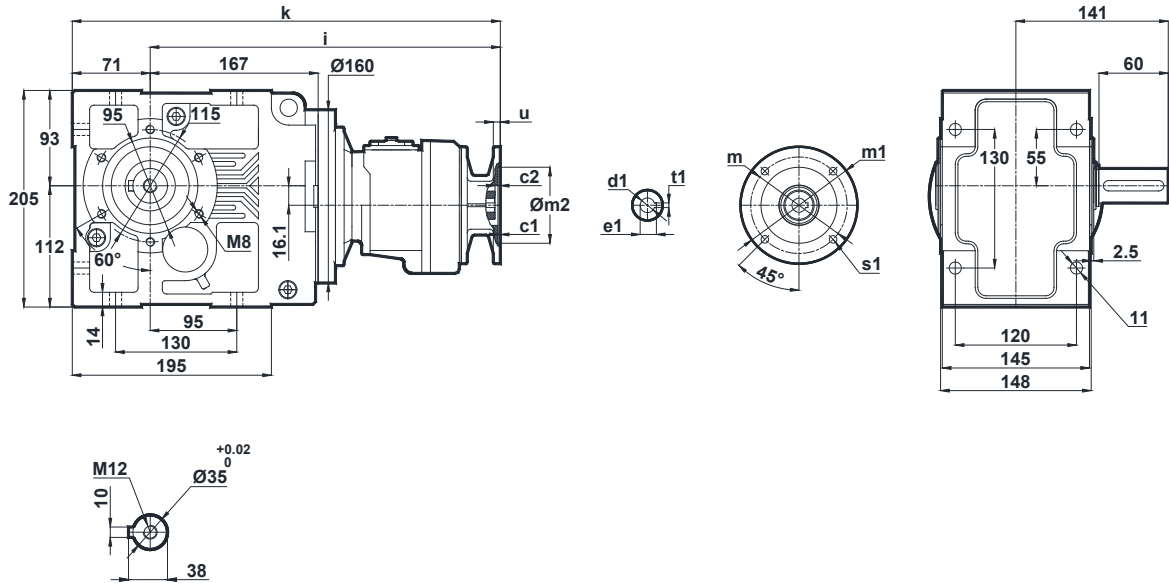

	c1	c2	s1	m	m1	m2	i	u	k	d1	t1	e1
63/B5	3.5	5	10	115	140	95	356	10	427	11	4	12.8
63/B14	2.5	5	5.5	75	90	60	356	10	427	11	4	12.8
71/B5	4	4.5	11	130	160	110	358	12	429	14	5	16.3
71/B14	3	4.5	7	85	105	70	358	10	429	14	5	16.3
80/B5	4	5	12	165	200	130	373	12	444	19	6	21.8
80/B14	4	5	7	100	120	80	373	12	444	19	6	21.8

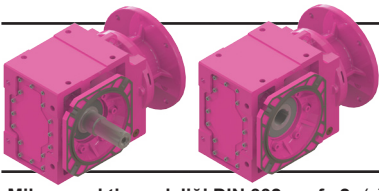

# Ölçü Sayfaları

## Dimension Pages

### Abmessungsseiten

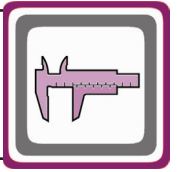

-Mil ucu çektirme deliği DIN 332 sayfa 2 / Tapped center hole to DIN 332, sheet 2 / Zentrierung mit Gewinde DIN 332, Blatt 2

KN275.02  
KN276.02

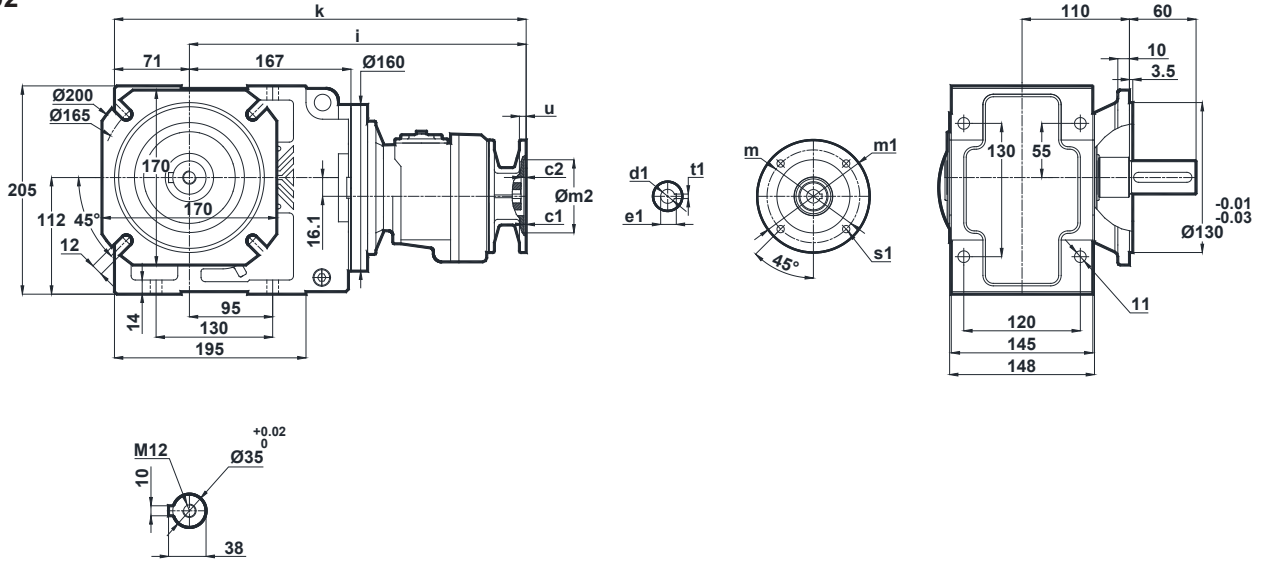

	c1	c2	s1	m	m1	m2	i	u	k	d1	t1	e1
63/B5	3.5	5	10	115	140	95	356	10	427	11	4	12.8
63/B14	2.5	5	5.5	75	90	60	356	10	427	11	4	12.8
71/B5	4	4.5	11	130	160	110	358	12	429	14	5	16.3
71/B14	3	4.5	7	85	105	70	358	10	429	14	5	16.3
80/B5	4	5	12	165	200	130	373	12	444	19	6	21.8
80/B14	4	5	7	100	120	80	373	12	444	19	6	21.8

KN275.03  
KN276.03

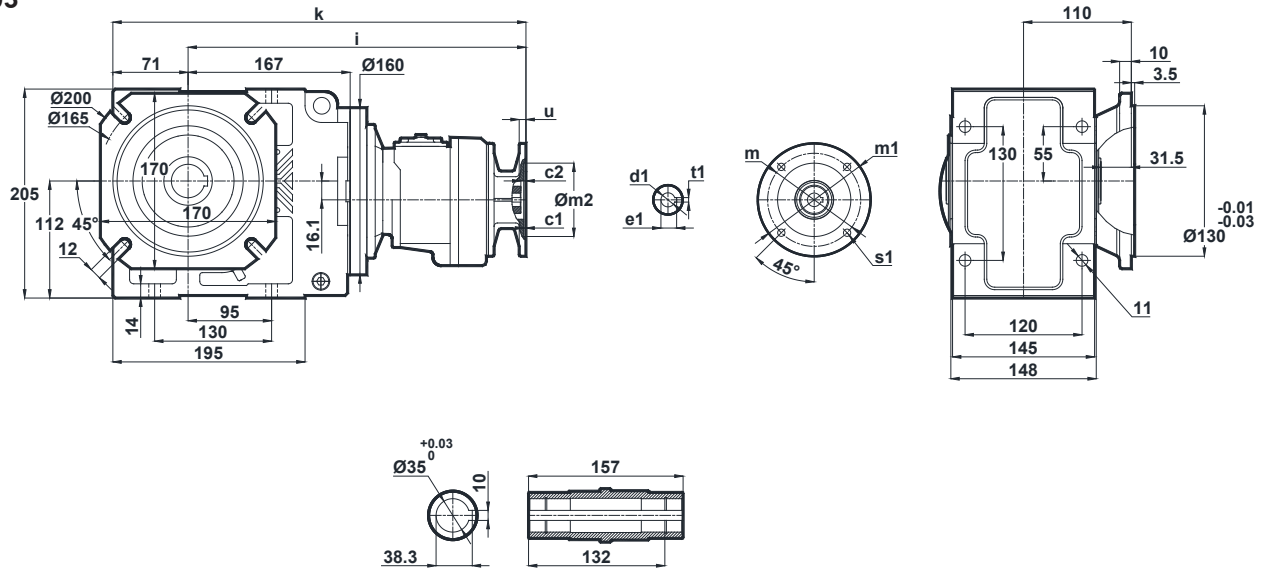

	c1	c2	s1	m	m1	m2	i	u	k	d1	t1	e1
63/B5	3.5	5	10	115	140	95	356	10	427	11	4	12.8
63/B14	2.5	5	5.5	75	90	60	356	10	427	11	4	12.8
71/B5	4	4.5	11	130	160	110	358	12	429	14	5	16.3
71/B14	3	4.5	7	85	105	70	358	10	429	14	5	16.3
80/B5	4	5	12	165	200	130	373	12	444	19	6	21.8
80/B14	4	5	7	100	120	80	373	12	444	19	6	21.8

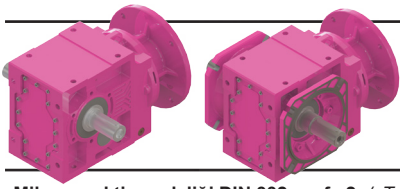

# Ölçü Sayfaları

## Dimension Pages

### Abmessungsseiten

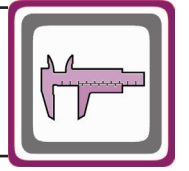

-Mil ucu çekirme deliği DIN 332 sayfa 2 / Tapped center hole to DIN 332, sheet 2 / Zentrierung mit Gewinde DIN 332, Blatt 2

KN275.04  
KN276.04

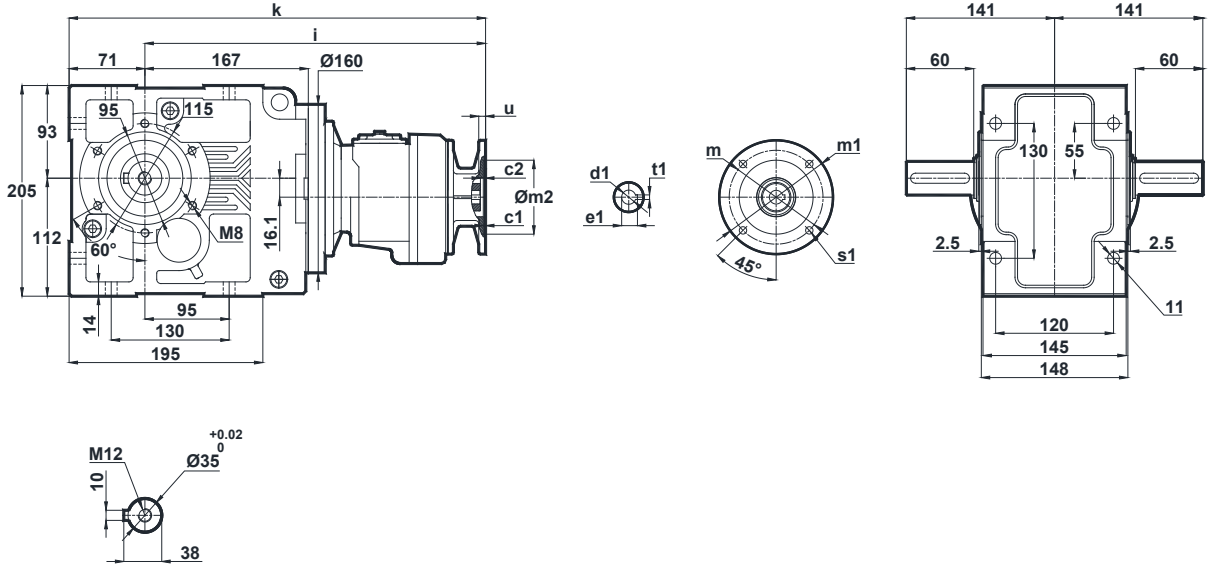

	c1	c2	s1	m	m1	m2	i	u	k	d1	t1	e1
63/B5	3.5	5	10	115	140	95	356	10	427	11	4	12.8
63/B14	2.5	5	5.5	75	90	60	356	10	427	11	4	12.8
71/B5	4	4.5	11	130	160	110	358	12	429	14	5	16.3
71/B14	3	4.5	7	85	105	70	358	10	429	14	5	16.3
80/B5	4	5	12	165	200	130	373	12	444	19	6	21.8
80/B14	4	5	7	100	120	80	373	12	444	19	6	21.8

KN275.05  
KN276.05

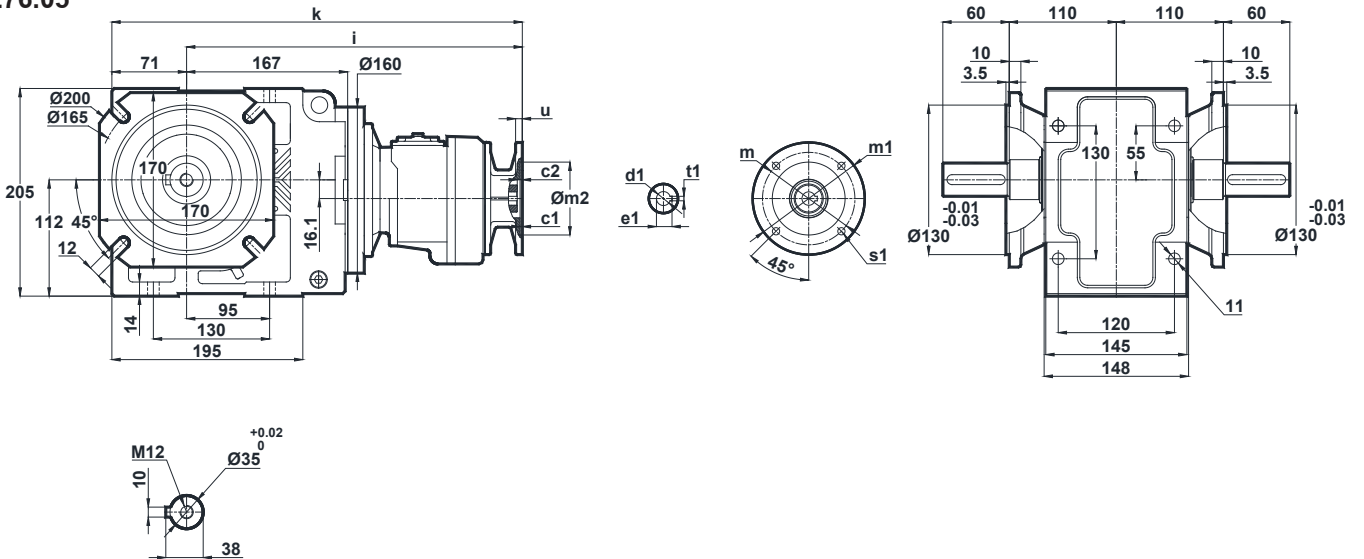

	c1	c2	s1	m	m1	m2	i	u	k	d1	t1	e1
63/B5	3.5	5	10	115	140	95	356	10	427	11	4	12.8
63/B14	2.5	5	5.5	75	90	60	356	10	427	11	4	12.8
71/B5	4	4.5	11	130	160	110	358	12	429	14	5	16.3
71/B14	3	4.5	7	85	105	70	358	10	429	14	5	16.3
80/B5	4	5	12	165	200	130	373	12	444	19	6	21.8
80/B14	4	5	7	100	120	80	373	12	444	19	6	21.8

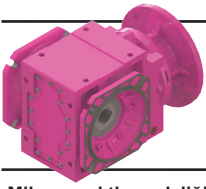

# Ölçü Sayfaları

## Dimension Pages

### Abmessungsseiten

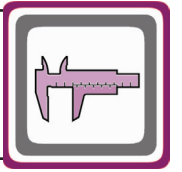

-Mil ucu çekirme deliği DIN 332 sayfa 2 / Tapped center hole to DIN 332, sheet 2 / Zentrierung mit Gewinde DIN 332, Blatt 2

KN275.08  
KN276.08

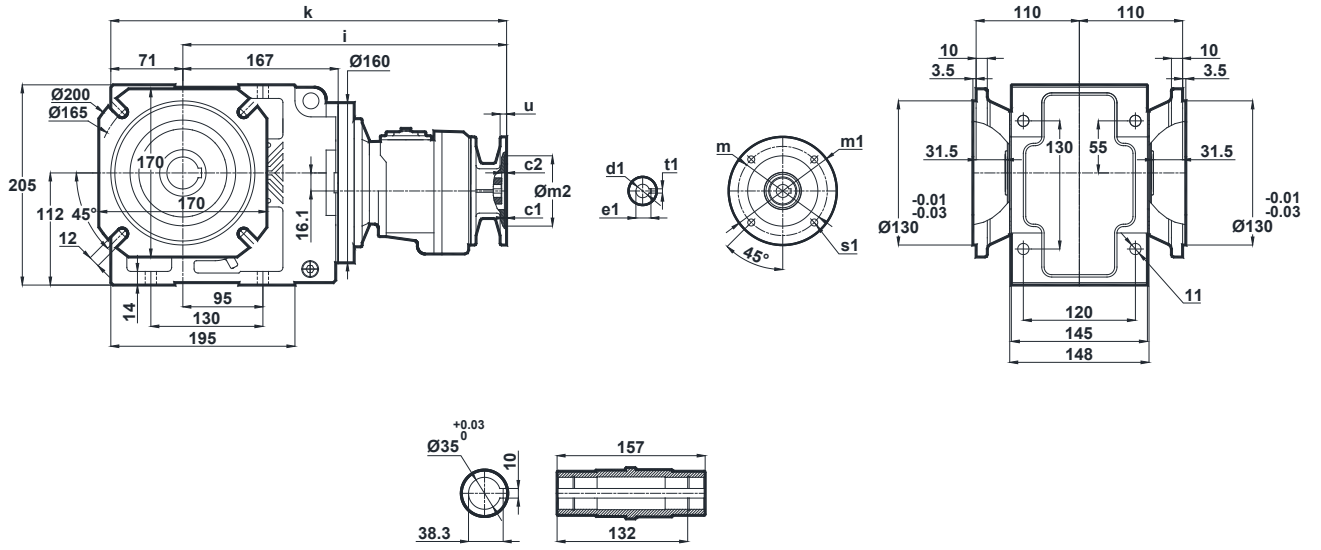

	c1	c2	s1	m	m1	m2	i	u	k	d1	t1	e1
<b>63/B5</b>	3.5	5	10	115	140	95	356	10	427	11	4	12.8
<b>63/B14</b>	2.5	5	5.5	75	90	60	356	10	427	11	4	12.8
<b>71/B5</b>	4	4.5	11	130	160	110	358	12	429	14	5	16.3
<b>71/B14</b>	3	4.5	7	85	105	70	358	10	429	14	5	16.3
<b>80/B5</b>	4	5	12	165	200	130	373	12	444	19	6	21.8
<b>80/B14</b>	4	5	7	100	120	80	373	12	444	19	6	21.8

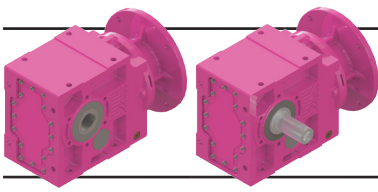

# Ölçü Sayfaları

## Dimension Pages

### Abmessungsseiten

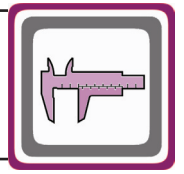

-Mil ucu çekirme deliği DIN 332 sayfa 2 / Tapped center hole to DIN 332, sheet 2 / Zentrierung mit Gewinde DIN 332, Blatt 2

#### KN373.00

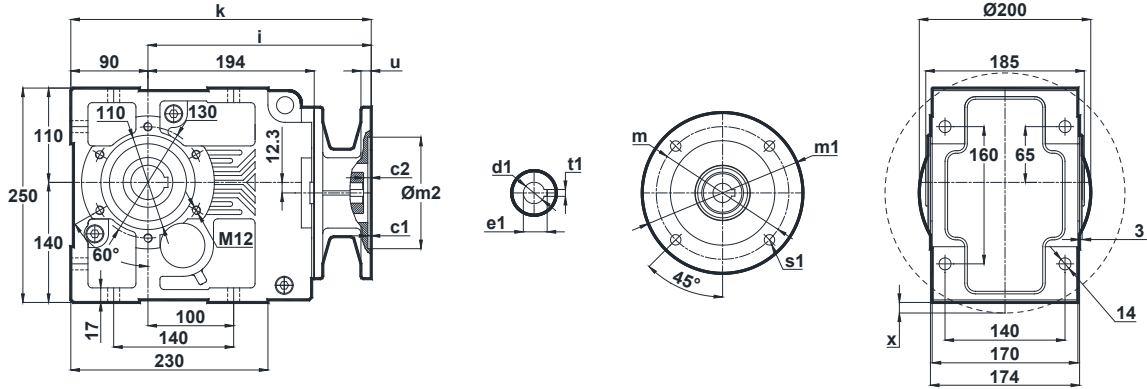

Std.

Ops.

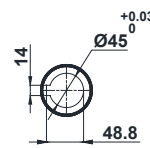
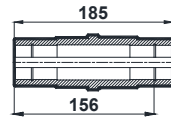
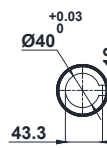

x: Motor Ayak bağlantı yüzeyinin altında ise  
x: If Motor is lower than foot mounting plane  
x: Wenn der Motor unter der Fußmontageebene ist

	c1	c2	s1	m	m1	m2	i	u	k	d1	t1	e1	x
71/B5	4	9	11	130	160	110	261	12	351	14	5	16.3	-
80/B5	4	9	12	165	200	130	261	12	351	19	6	21.8	-
80/B14	4	9	7	100	120	80	261	12	351	19	6	21.8	-
90/B5	4	9	12	165	200	130	261	12	351	24	8	27.3	-
90/B14	4	9	9	115	140	95	261	12	351	24	8	26.3	-
100/B5	4.5	9	15	215	250	180	278	15	368	28	8	31.3	-
100/B14	3.5	9	9	130	160	110	278	15	368	28	8	31.3	-
112/B5	4.5	9	15	215	250	180	278	15	368	28	8	31.3	-
112/B14	3.5	9	9	130	160	110	278	15	368	28	8	31.3	-
132/B5	4.5	7	15	265	300	230	298	15	388	38	10	41.3	22.3
132/B14	4.5	9	11	165	200	130	298	15	388	38	10	41.3	-

#### KN373.01

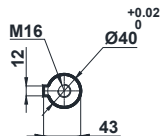
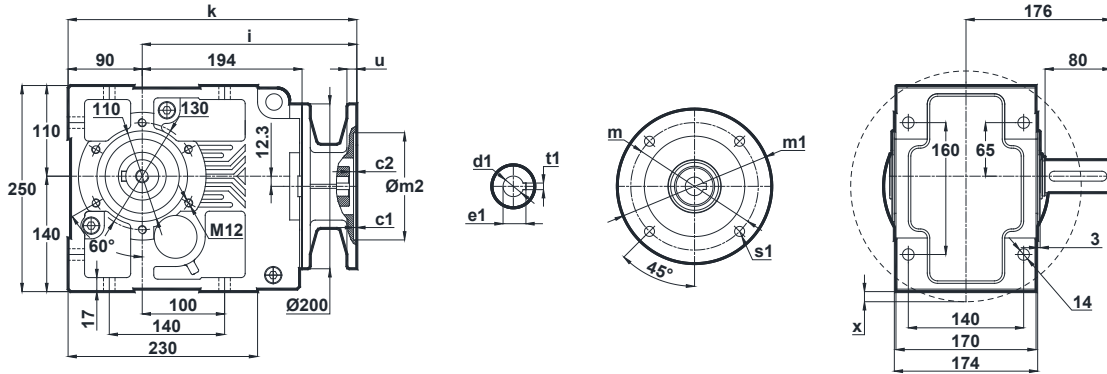

x: Motor Ayak bağlantı yüzeyinin altında ise  
x: If Motor is lower than foot mounting plane  
x: Wenn der Motor unter der Fußmontageebene ist

	c1	c2	s1	m	m1	m2	i	u	k	d1	t1	e1	x
71/B5	4	9	11	130	160	110	261	12	351	14	5	16.3	-
80/B5	4	9	12	165	200	130	261	12	351	19	6	21.8	-
80/B14	4	9	7	100	120	80	261	12	351	19	6	21.8	-
90/B5	4	9	12	165	200	130	261	12	351	24	8	27.3	-
90/B14	4	9	9	115	140	95	261	12	351	24	8	26.3	-
100/B5	4.5	9	15	215	250	180	278	15	368	28	8	31.3	-
100/B14	3.5	9	9	130	160	110	278	15	368	28	8	31.3	-
112/B5	4.5	9	15	215	250	180	278	15	368	28	8	31.3	-
112/B14	3.5	9	9	130	160	110	278	15	368	28	8	31.3	-
132/B5	4.5	7	15	265	300	230	298	15	388	38	10	41.3	22.3
132/B14	4.5	9	11	165	200	130	298	15	388	38	10	41.3	-

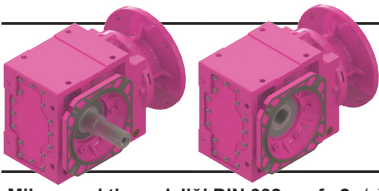

# Ölçü Sayfaları

## Dimension Pages

### Abmessungsseiten

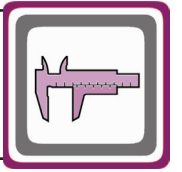

-Mil ucu çekirme deliği DIN 332 sayfa 2 / Tapped center hole to DIN 332, sheet 2 / Zentrierung mit Gewinde DIN 332, Blatt 2

#### KN373.02

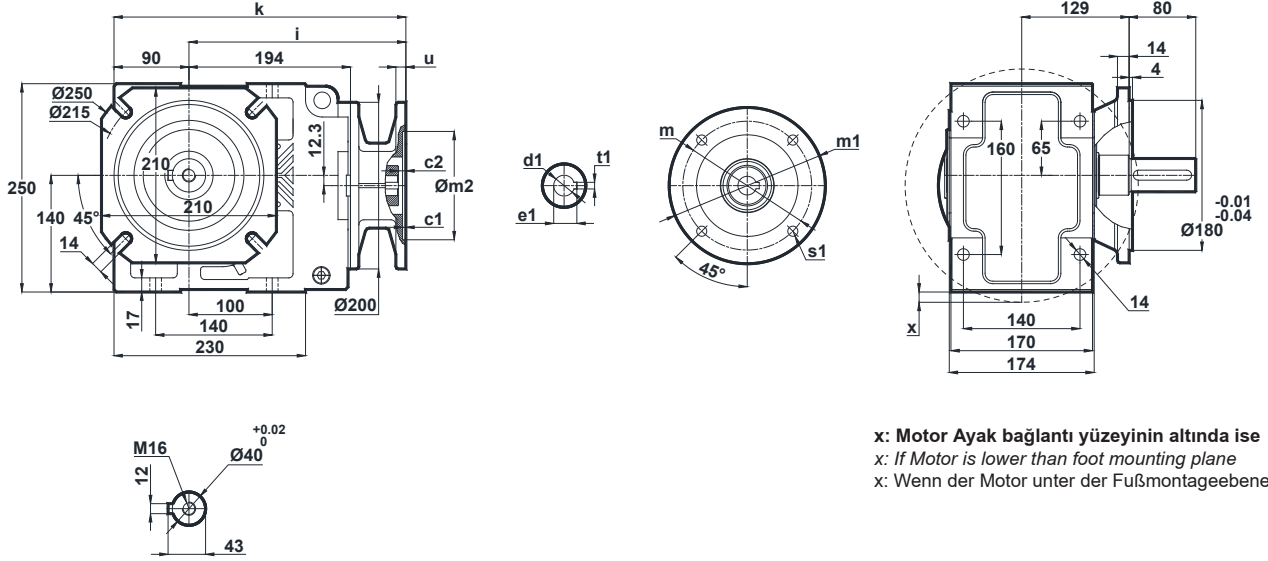

**x: Motor Ayak bağlantı yüzeyinin altında ise**  
*x: If Motor is lower than foot mounting plane*  
*x: Wenn der Motor unter der Fußmontageebene ist*

	c1	c2	s1	m	m1	m2	i	u	k	d1	t1	e1	x
71/B5	4	9	11	130	160	110	261	12	351	14	5	16.3	-
80/B5	4	9	12	165	200	130	261	12	351	19	6	21.8	-
80/B14	4	9	7	100	120	80	261	12	351	19	6	21.8	-
90/B5	4	9	12	165	200	130	261	12	351	24	8	27.3	-
90/B14	4	9	9	115	140	95	261	12	351	24	8	26.3	-
100/B5	4.5	9	15	215	250	180	278	15	368	28	8	31.3	-
100/B14	3.5	9	9	130	160	110	278	15	368	28	8	31.3	-
112/B5	4.5	9	15	215	250	180	278	15	368	28	8	31.3	-
112/B14	3.5	9	9	130	160	110	278	15	368	28	8	31.3	-
132/B5	4.5	7	15	265	300	230	298	15	388	38	10	41.3	22.3
132/B14	9	9	11	165	200	130	298	15	388	38	10	41.3	-

#### KN373.03

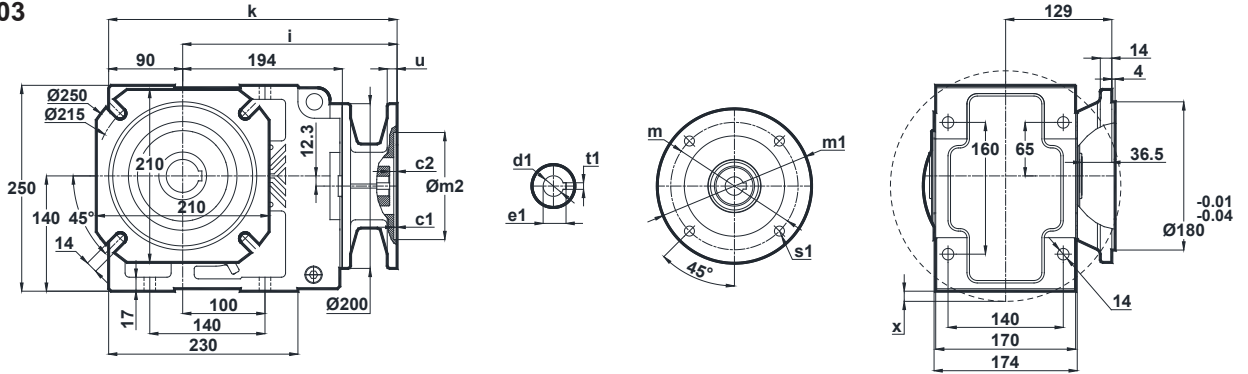

**Std.**

**Ops.**

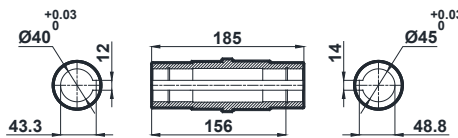

**x: Motor Ayak bağlantı yüzeyinin altında ise**  
*x: If Motor is lower than foot mounting plane*  
*x: Wenn der Motor unter der Fußmontageebene ist*

	c1	c2	s1	m	m1	m2	i	u	k	d1	t1	e1	x
71/B5	4	9	11	130	160	110	261	12	351	14	5	16.3	-
80/B5	4	9	12	165	200	130	261	12	351	19	6	21.8	-
80/B14	4	9	7	100	120	80	261	12	351	19	6	21.8	-
90/B5	4	9	12	165	200	130	261	12	351	24	8	27.3	-
90/B14	4	9	9	115	140	95	261	12	351	24	8	26.3	-
100/B5	4.5	9	15	215	250	180	278	15	368	28	8	31.3	-
100/B14	3.5	9	9	130	160	110	278	15	368	28	8	31.3	-
112/B5	4.5	9	15	215	250	180	278	15	368	28	8	31.3	-
112/B14	3.5	9	9	130	160	110	278	15	368	28	8	31.3	-
132/B5	4.5	7	15	265	300	230	298	15	388	38	10	41.3	22.3
132/B14	9	9	11	165	200	130	298	15	388	38	10	41.3	-

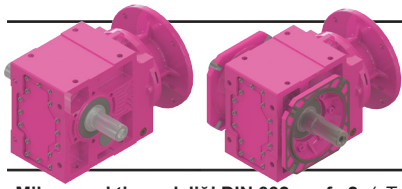

# Ölçü Sayfaları

## Dimension Pages

### Abmessungsseiten

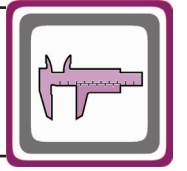

-Mil ucu çekirme deliği DIN 332 sayfa 2 / Tapped center hole to DIN 332, sheet 2 / Zentrierung mit Gewinde DIN 332, Blatt 2

#### KN373.04

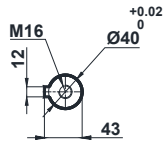
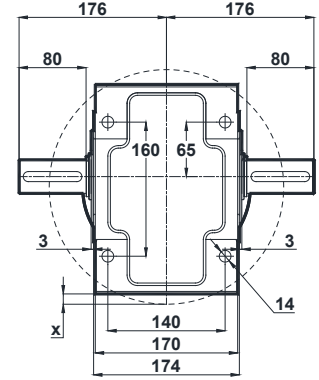
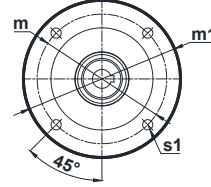
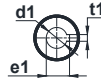
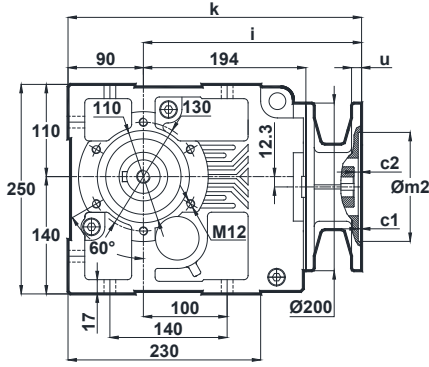

x: Motor Ayak bağlantı yüzeyinin altında ise  
x: If Motor is lower than foot mounting plane  
x: Wenn der Motor unter der Fußmontageebene ist

	c1	c2	s1	m	m1	m2	i	u	k	d1	t1	e1	x
71/B5	4	9	11	130	160	110	261	12	351	14	5	16.3	-
80/B5	4	9	12	165	200	130	261	12	351	19	6	21.8	-
80/B14	4	9	7	100	120	80	261	12	351	19	6	21.8	-
90/B5	4	9	12	165	200	130	261	12	351	24	8	27.3	-
90/B14	4	9	9	115	140	95	261	12	351	24	8	26.3	-
100/B5	4.5	9	15	215	250	180	278	15	368	28	8	31.3	-
100/B14	3.5	9	9	130	160	110	278	15	368	28	8	31.3	-
112/B5	4.5	9	15	215	250	180	278	15	368	28	8	31.3	-
112/B14	3.5	9	9	130	160	110	278	15	368	28	8	31.3	-
132/B5	4.5	7	15	265	300	230	298	15	388	38	10	41.3	22.3
132/B14	9	9	11	165	200	130	298	15	388	38	10	41.3	-

#### KN373.05

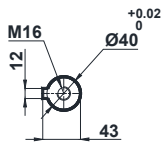
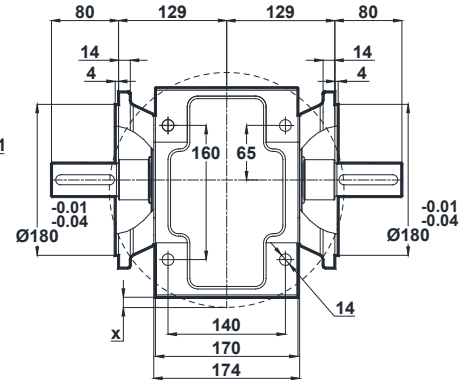
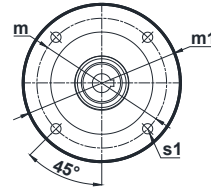
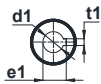
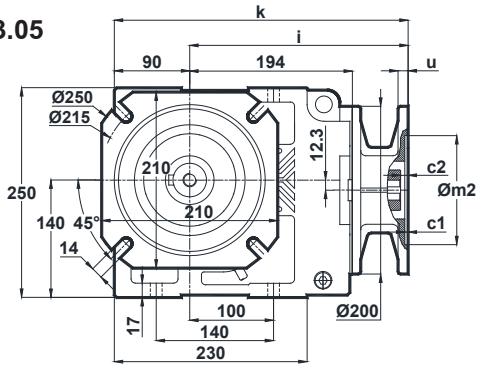

x: Motor Ayak bağlantı yüzeyinin altında ise  
x: If Motor is lower than foot mounting plane  
x: Wenn der Motor unter der Fußmontageebene ist

	c1	c2	s1	m	m1	m2	i	u	k	d1	t1	e1	x
71/B5	4	9	11	130	160	110	261	12	351	14	5	16.3	-
80/B5	4	9	12	165	200	130	261	12	351	19	6	21.8	-
80/B14	4	9	7	100	120	80	261	12	351	19	6	21.8	-
90/B5	4	9	12	165	200	130	261	12	351	24	8	27.3	-
90/B14	4	9	9	115	140	95	261	12	351	24	8	26.3	-
100/B5	4.5	9	15	215	250	180	278	15	368	28	8	31.3	-
100/B14	3.5	9	9	130	160	110	278	15	368	28	8	31.3	-
112/B5	4.5	9	15	215	250	180	278	15	368	28	8	31.3	-
112/B14	3.5	9	9	130	160	110	278	15	368	28	8	31.3	-
132/B5	4.5	7	15	265	300	230	298	15	388	38	10	41.3	22.3
132/B14	9	9	11	165	200	130	298	15	388	38	10	41.3	-



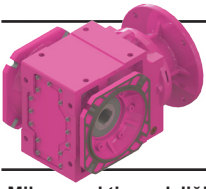

# Ölçü Sayfaları

## Dimension Pages

### Abmessungsseiten

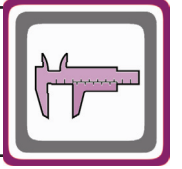

-Mil ucu çektirme deliği DIN 332 sayfa 2 / Tapped center hole to DIN 332, sheet 2 / Zentrierung mit Gewinde DIN 332, Blatt 2

KN373.08

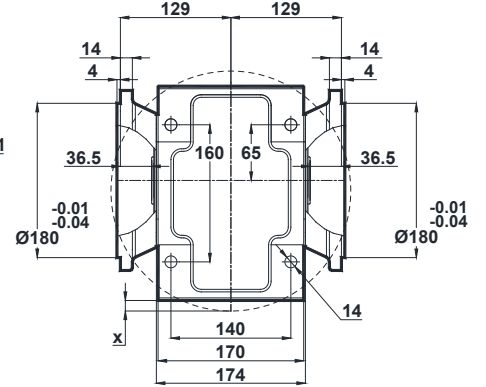
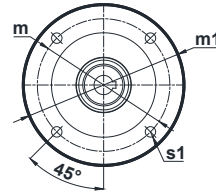
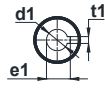
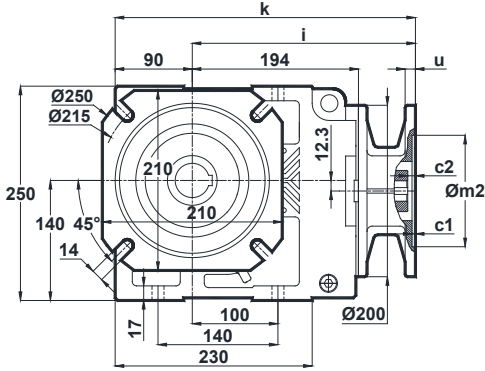

Std.

Ops.

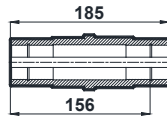
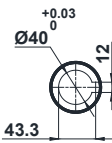

x: Motor Ayak bağlantı yüzeyinin altında ise  
x: If Motor is lower than foot mounting plane  
x: Wenn der Motor unter der Fußmontageebene ist

	c1	c2	s1	m	m1	m2	i	u	k	d1	t1	e1	x
71/B5	4	9	11	130	160	110	261	12	351	14	5	16.3	-
80/B5	4	9	12	165	200	130	261	12	351	19	6	21.8	-
80/B14	4	9	7	100	120	80	261	12	351	19	6	21.8	-
90/B5	4	9	12	165	200	130	261	12	351	24	8	27.3	-
90/B14	4	9	9	115	140	95	261	12	351	24	8	26.3	-
100/B5	4.5	9	15	215	250	180	278	15	368	28	8	31.3	-
100/B14	3.5	9	9	130	160	110	278	15	368	28	8	31.3	-
112/B5	4.5	9	15	215	250	180	278	15	368	28	8	31.3	-
112/B14	3.5	9	9	130	160	110	278	15	368	28	8	31.3	-
132/B5	4.5	7	15	265	300	230	298	15	388	38	10	41.3	22.3
132/B14	4.5	9	11	165	200	130	298	15	388	38	10	41.3	-

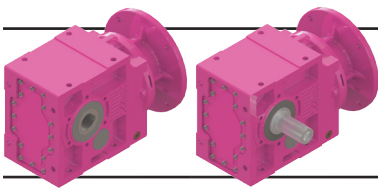

# Ölçü Sayfaları

## Dimension Pages

### Abmessungsseiten

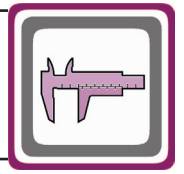

-Mil ucu çekirme deliği DIN 332 sayfa 2 / Tapped center hole to DIN 332, sheet 2 / Zentrierung mit Gewinde DIN 332, Blatt 2

#### KN374.00

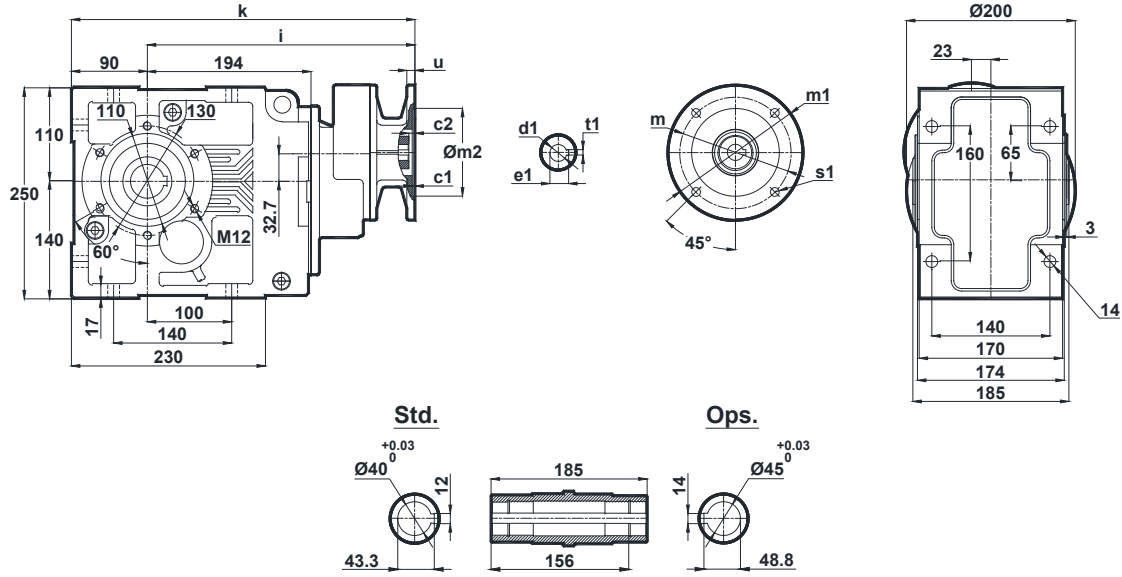

	c1	c2	s1	m	m1	m2	i	u	k	d1	t1	e1
63/B5	3.5	8	9	115	140	95	338	12	428	11	4	12.8
71/B5	4	8.5	11	130	160	110	309	12	399	14	5	16.3
71/B14	3		7	85	105	70		10				
80/B5	4	5	12	165	200	130	338	12	428	19	6	21.8
80/B14			7	100	120	80						

#### KN374.01

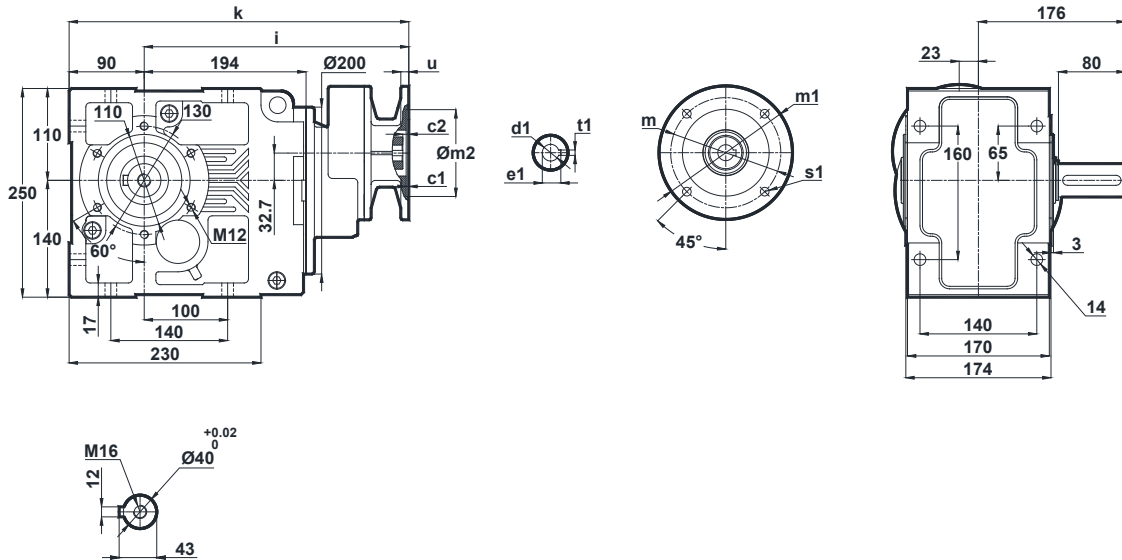

	c1	c2	s1	m	m1	m2	i	u	k	d1	t1	e1
63/B5	3.5	8	9	115	140	95	338	12	428	11	4	12.8
71/B5	4	8.5	11	130	160	110	309	12	399	14	5	16.3
71/B14	3		7	85	105	70		10				
80/B5	4	5	12	165	200	130	338	12	428	19	6	21.8
80/B14			7	100	120	80						

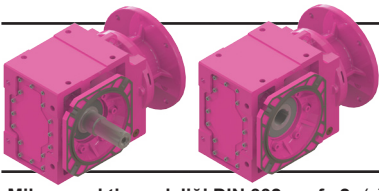

# Ölçü Sayfaları

## Dimension Pages

### Abmessungsseiten

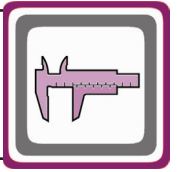

-Mil ucu çekirme deliği DIN 332 sayfa 2 / Tapped center hole to DIN 332, sheet 2 / Zentrierung mit Gewinde DIN 332, Blatt 2

#### KN374.02

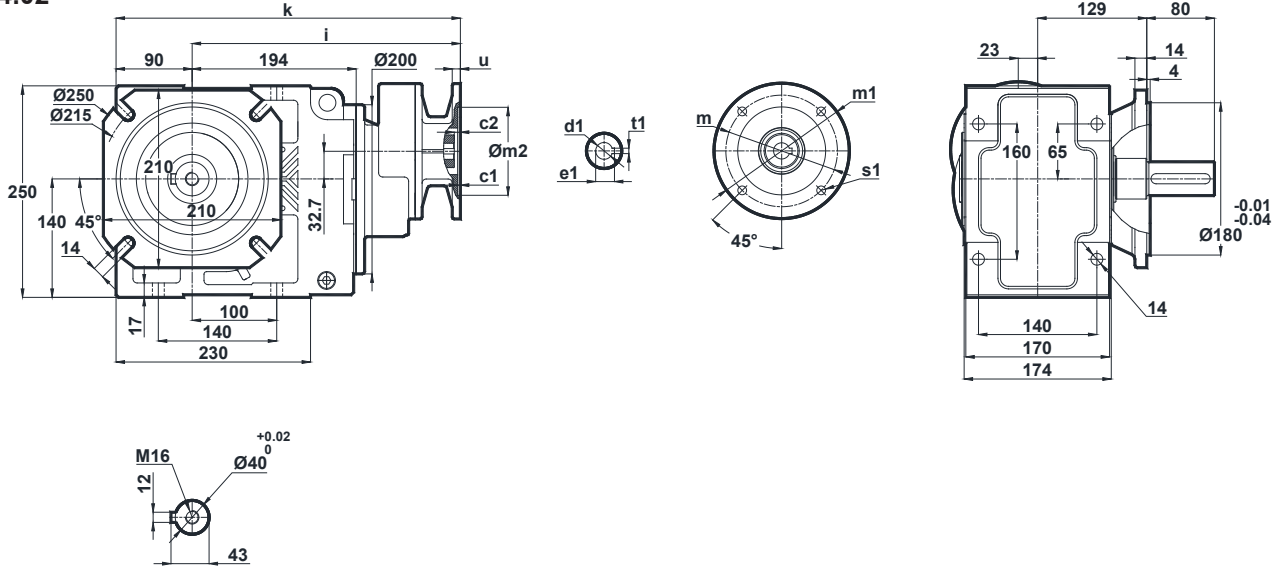

	c1	c2	s1	m	m1	m2	i	u	k	d1	t1	e1
63/B5	3.5	8	9	115	140	95	338	12	428	11	4	12.8
71/B5	4	8.5	11	130	160	110	309	12	399	14	5	16.3
71/B14	3		7	85	105	70		10				
80/B5	4	5	12	165	200	130	338	12	428	19	6	21.8
80/B14			7	100	120	80						

#### KN374.03

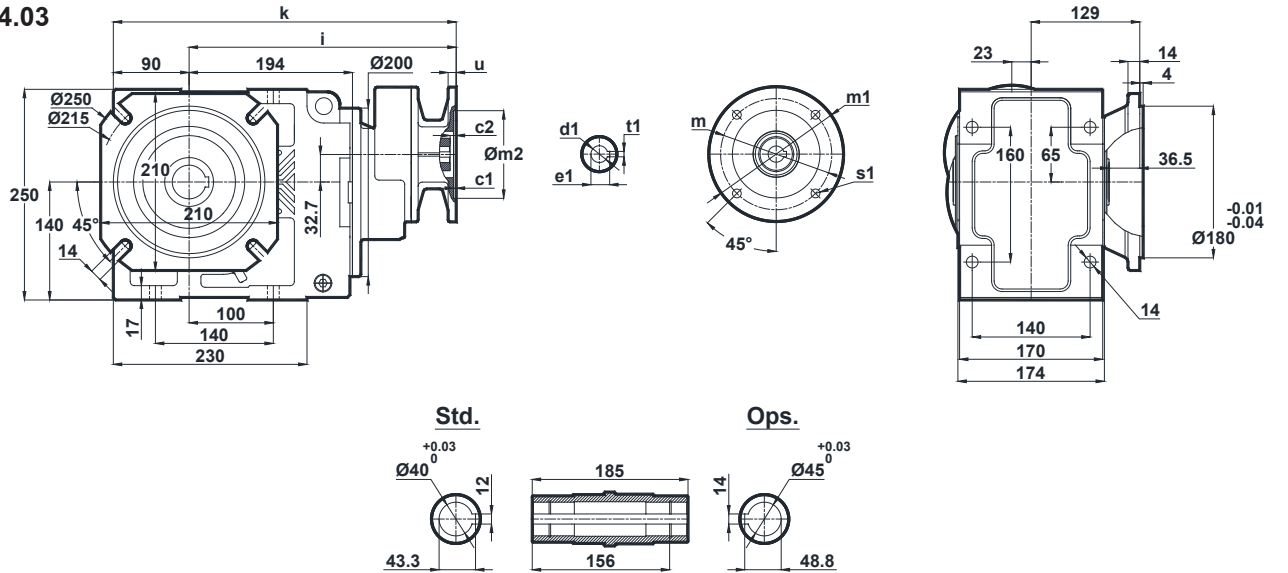

	c1	c2	s1	m	m1	m2	i	u	k	d1	t1	e1
63/B5	3.5	8	9	115	140	95	338	12	428	11	4	12.8
71/B5	4	8.5	11	130	160	110	309	12	399	14	5	16.3
71/B14	3		7	85	105	70		10				
80/B5	4	5	12	165	200	130	338	12	428	19	6	21.8
80/B14			7	100	120	80						

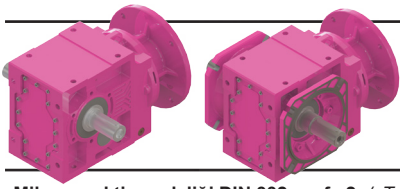

# Ölçü Sayfaları

## Dimension Pages

### Abmessungsseiten

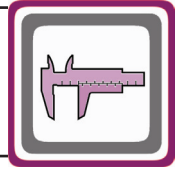

-Mil ucu çekirme deliği DIN 332 sayfa 2 / Tapped center hole to DIN 332, sheet 2 / Zentrierung mit Gewinde DIN 332, Blatt 2

#### KN374.04

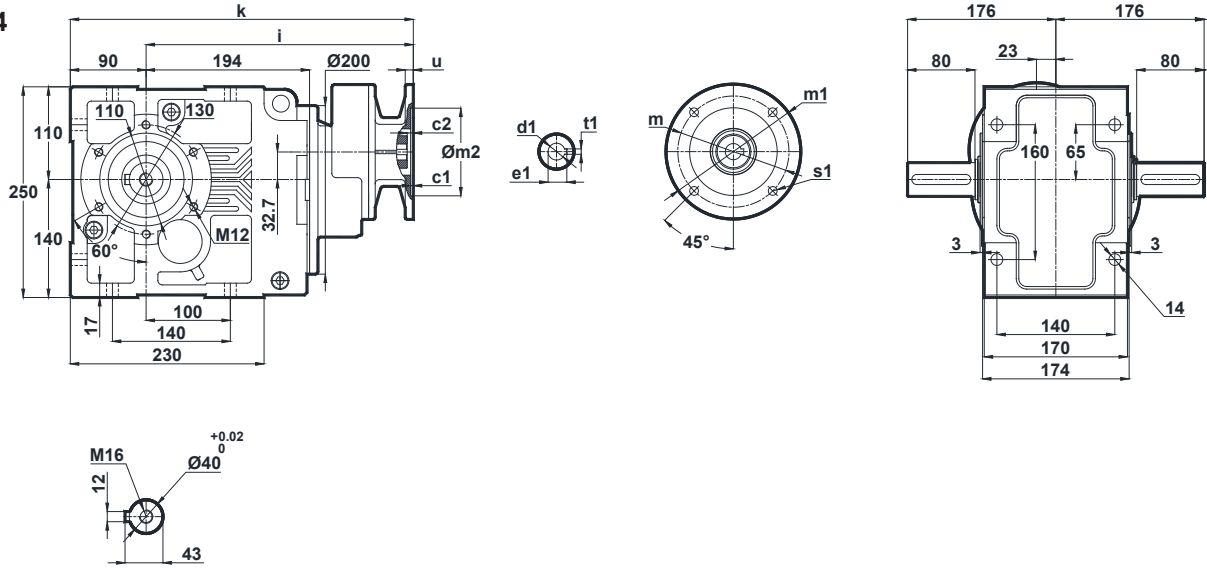

	c1	c2	s1	m	m1	m2	i	u	k	d1	t1	e1
63/B5	3.5	8	9	115	140	95	338	12	428	11	4	12.8
71/B5	4	8.5	11	130	160	110	309	12	399	14	5	16.3
71/B14	3		7	85	105	70		10				
80/B5	4	5	12	165	200	130	338	12	428	19	6	21.8
80/B14			7	100	120	80						

#### KN374.05

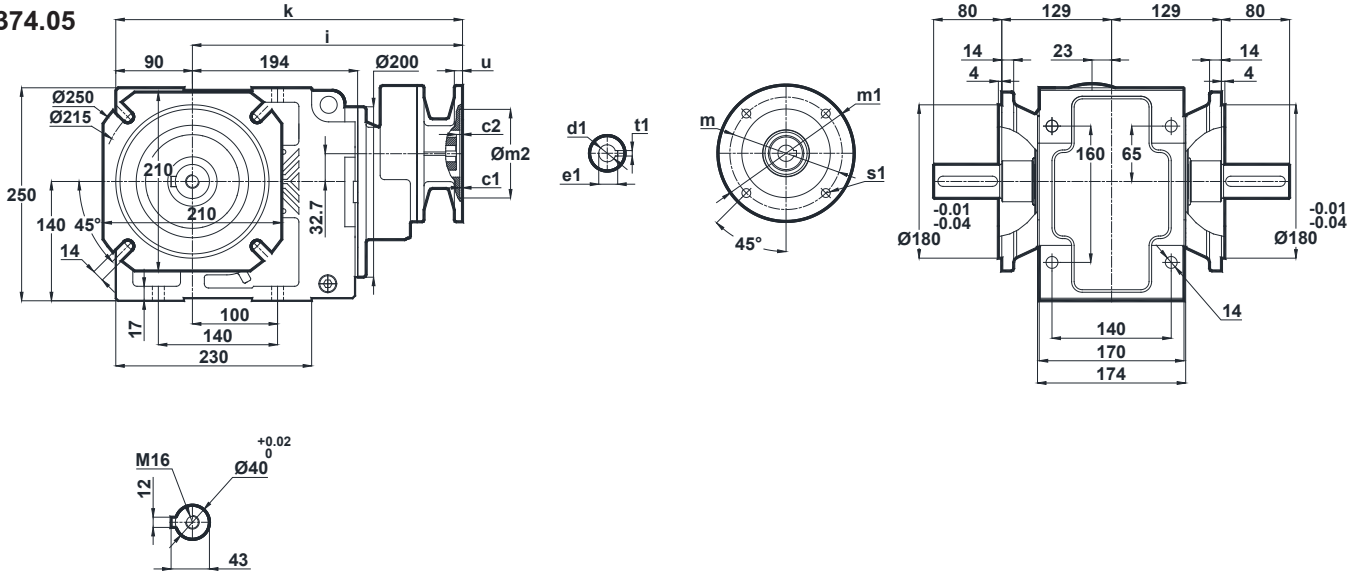

	c1	c2	s1	m	m1	m2	i	u	k	d1	t1	e1
63/B5	3.5	8	9	115	140	95	338	12	428	11	4	12.8
71/B5	4	8.5	11	130	160	110	309	12	399	14	5	16.3
71/B14	3		7	85	105	70		10				
80/B5	4	5	12	165	200	130	338	12	428	19	6	21.8
80/B14			7	100	120	80						

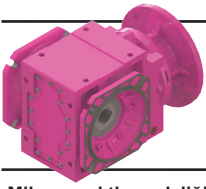

# Ölçü Sayfaları Dimension Pages Abmessungsseiten

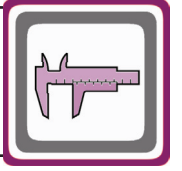

-Mil ucu çekirme deliği DIN 332 sayfa 2 / Tapped center hole to DIN 332, sheet 2 / Zentrierung mit Gewinde DIN 332, Blatt 2

KN374.08

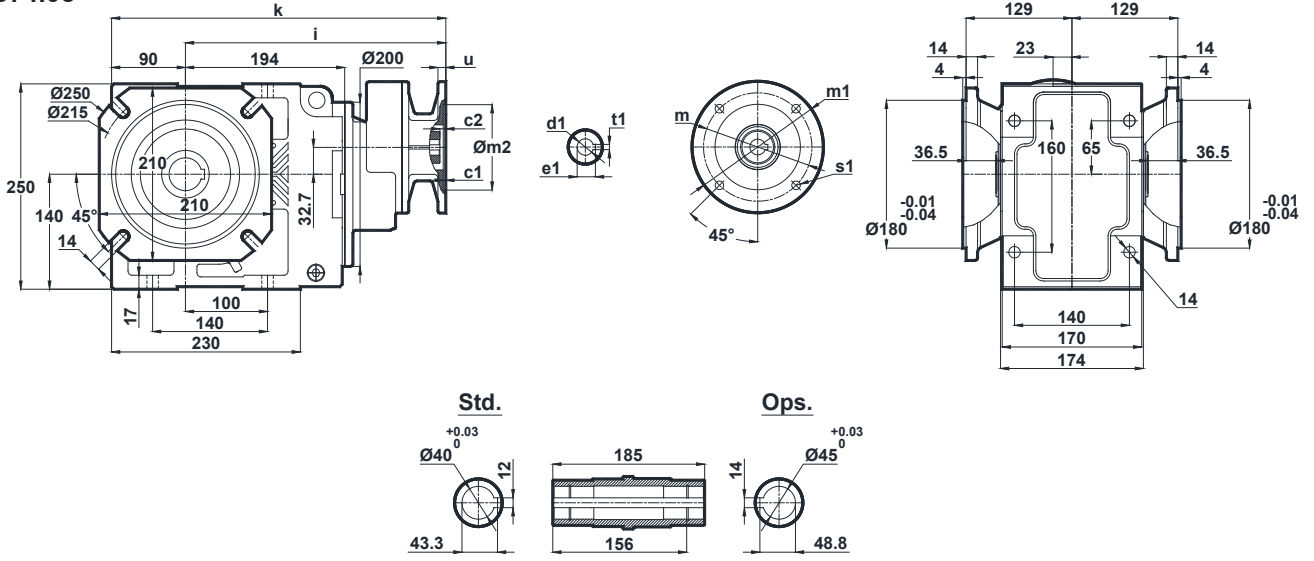

	c1	c2	s1	m	m1	m2	i	u	k	d1	t1	e1
63/B5	3.5	8	9	115	140	95	338	12	428	11	4	12.8
71/B5	4			130	160	110		12				
71/B14	3	8.5	7	85	105	70	309	10	399	14	5	16.3
80/B5	4	5	12	165	200	130	338	12	428	19	6	21.8
80/B14			7	100	120	80						

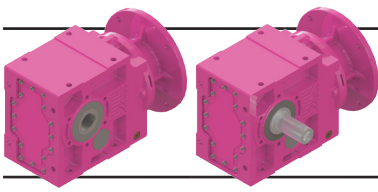

# Ölçü Sayfaları

## Dimension Pages

### Abmessungsseiten

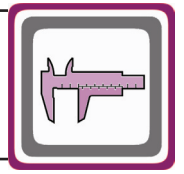

-Mil ucu çekirme deliği DIN 332 sayfa 2 / Tapped center hole to DIN 332, sheet 2 / Zentrierung mit Gewinde DIN 332, Blatt 2

KN375.00  
KN376.00

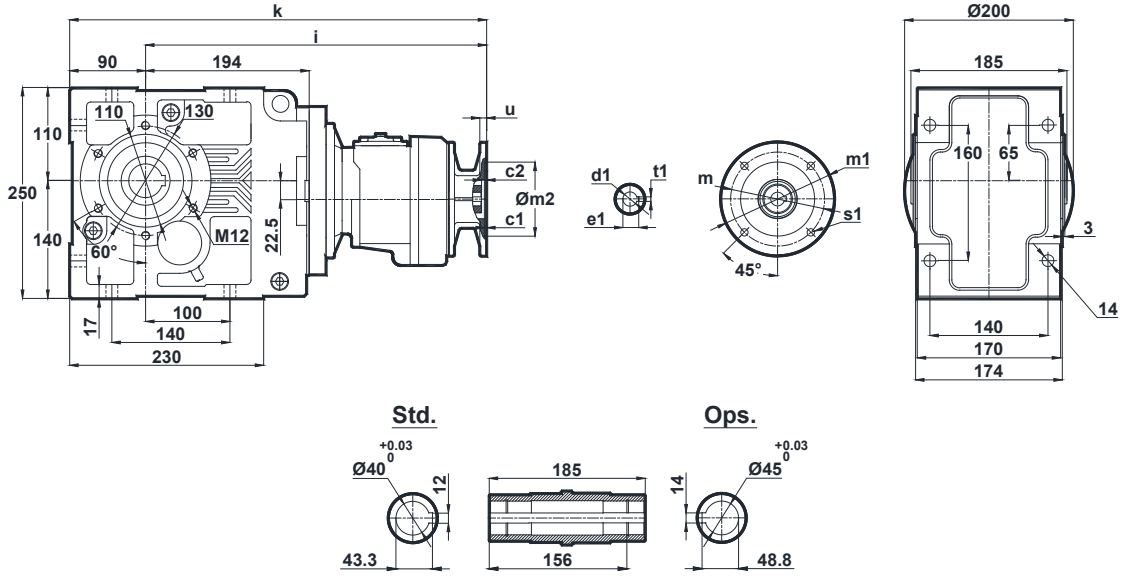

	c1	c2	s1	m	m1	m2	i	u	k	d1	t1	e1
63/B5	3.5	5	10	115	140	95	405	10	495	11	4	12.8
63/B14	2.5	5	5.5	75	90	60	405	10	495	11	4	12.8
71/B5	4	4.5	11	130	160	110	405	12	495	14	5	16.3
71/B14	3	4.5	7	85	105	70	405	10	495	14	5	16.3

KN375.01  
KN376.01

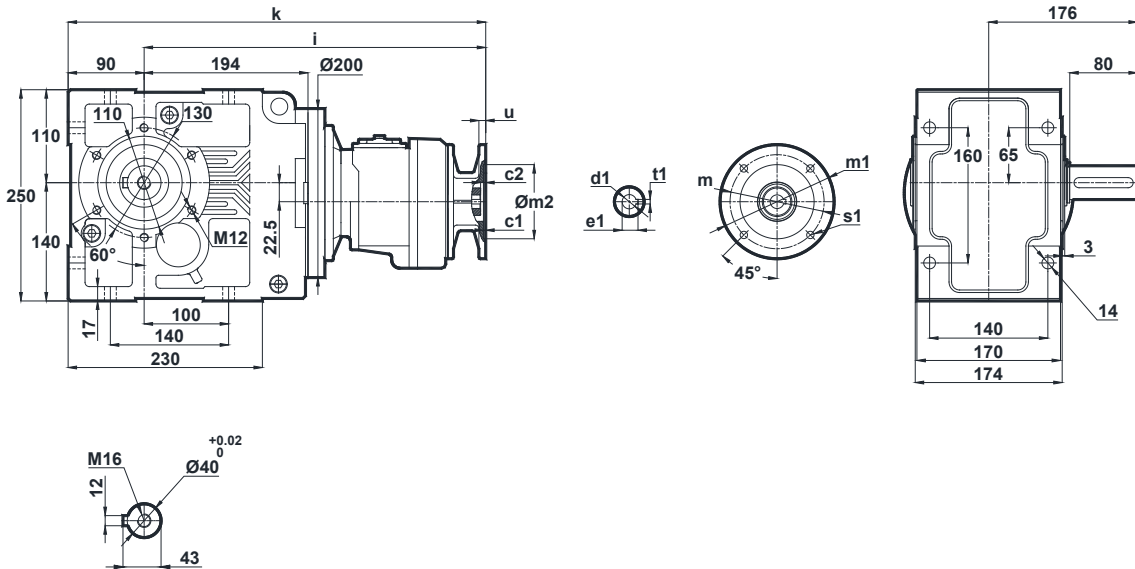

	c1	c2	s1	m	m1	m2	i	u	k	d1	t1	e1
63/B5	3.5	5	10	115	140	95	405	10	495	11	4	12.8
63/B14	2.5	5	5.5	75	90	60	405	10	495	11	4	12.8
71/B5	4	4.5	11	130	160	110	405	12	495	14	5	16.3
71/B14	3	4.5	7	85	105	70	405	10	495	14	5	16.3

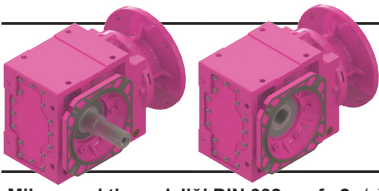

# Ölçü Sayfaları

## Dimension Pages

### Abmessungsseiten

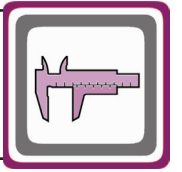

-Mil ucu çekirme deliği DIN 332 sayfa 2 / Tapped center hole to DIN 332, sheet 2 / Zentrierung mit Gewinde DIN 332, Blatt 2

KN375.02  
KN376.02

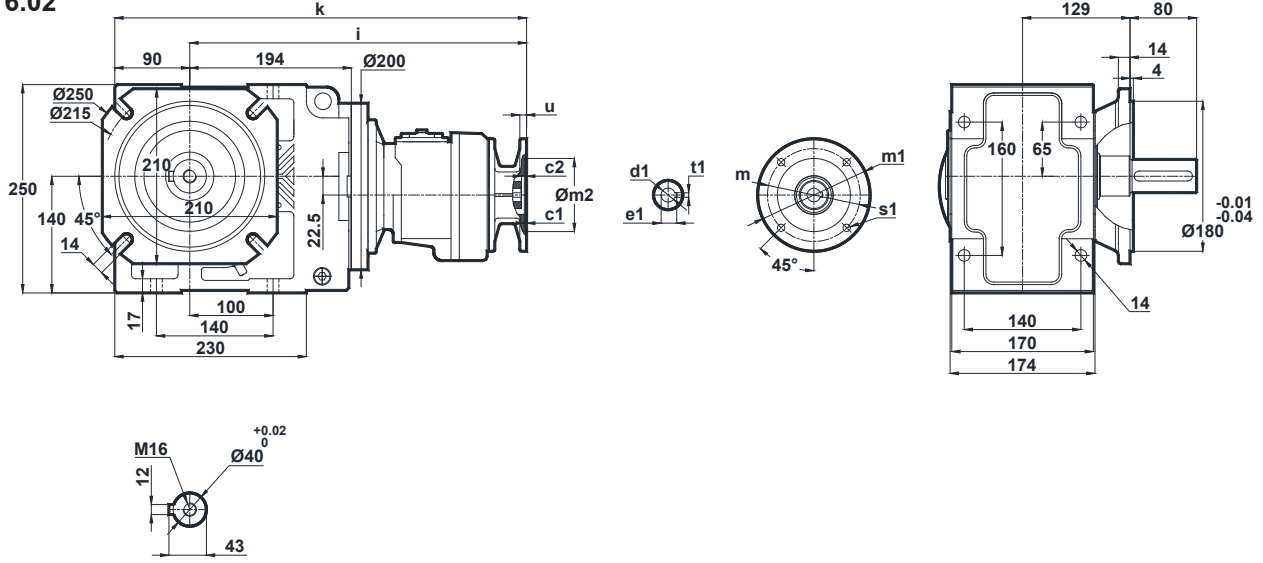

	c1	c2	s1	m	m1	m2	i	u	k	d1	t1	e1
63/B5	3.5	5	10	115	140	95	405	10	495	11	4	12.8
63/B14	2.5	5	5.5	75	90	60	405	10	495	11	4	12.8
71/B5	4	4.5	11	130	160	110	405	12	495	14	5	16.3
71/B14	3	4.5	7	85	105	70	405	10	495	14	5	16.3

KN375.03  
KN376.03

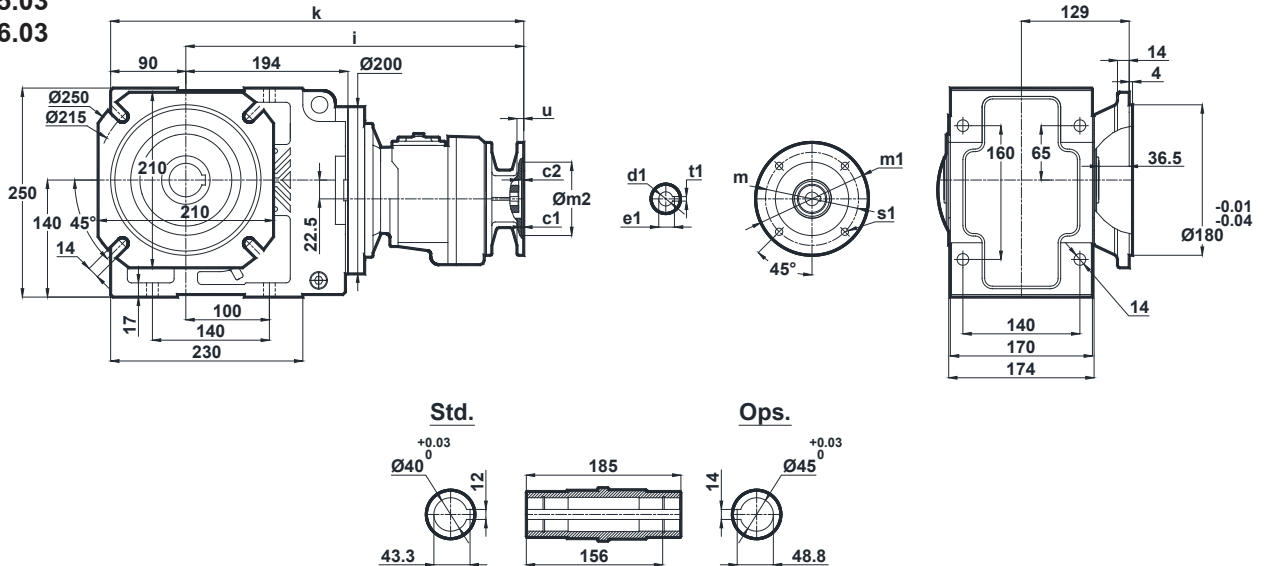

	c1	c2	s1	m	m1	m2	i	u	k	d1	t1	e1
63/B5	3.5	5	10	115	140	95	405	10	495	11	4	12.8
63/B14	2.5	5	5.5	75	90	60	405	10	495	11	4	12.8
71/B5	4	4.5	11	130	160	110	405	12	495	14	5	16.3
71/B14	3	4.5	7	85	105	70	405	10	495	14	5	16.3

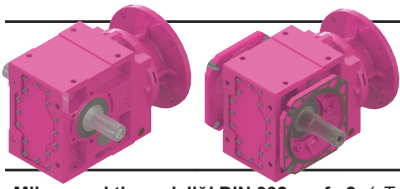

# Ölçü Sayfaları

## Dimension Pages

### Abmessungsseiten

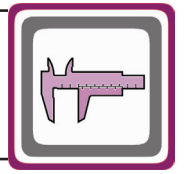

-Mil ucu çektirme deliği DIN 332 sayfa 2 / Tapped center hole to DIN 332, sheet 2 / Zentrierung mit Gewinde DIN 332, Blatt 2

KN375.04  
KN376.04

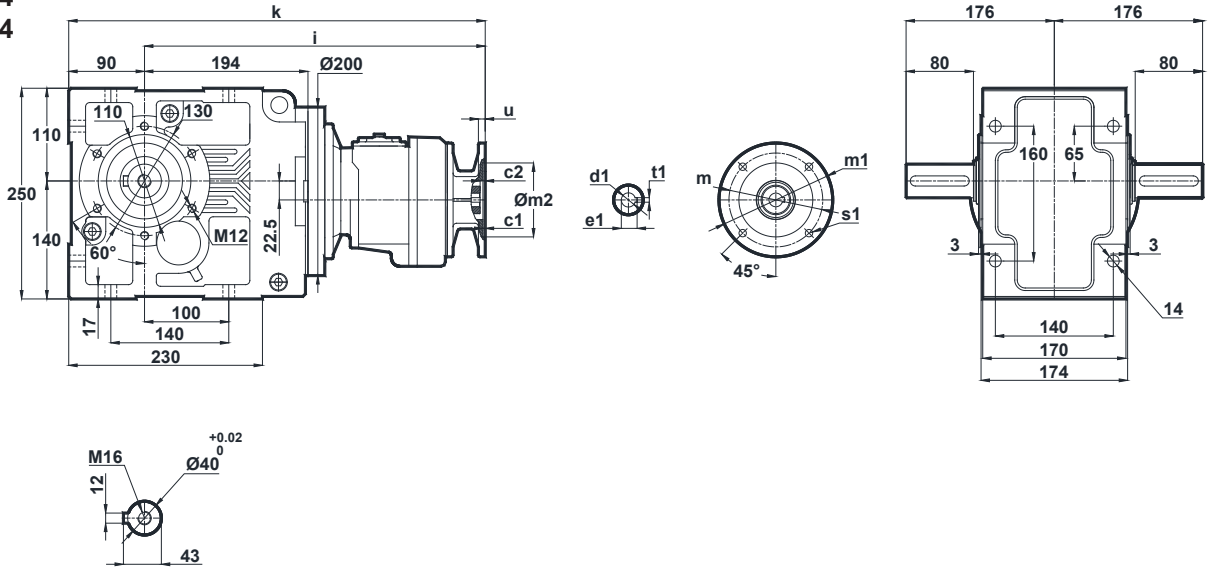

	c1	c2	s1	m	m1	m2	i	u	k	d1	t1	e1
63/B5	3.5	5	10	115	140	95	405	10	495	11	4	12.8
63/B14	2.5	5	5.5	75	90	60	405	10	495	11	4	12.8
71/B5	4	4.5	11	130	160	110	405	12	495	14	5	16.3
71/B14	3	4.5	7	85	105	70	405	10	495	14	5	16.3

KN375.05  
KN376.05

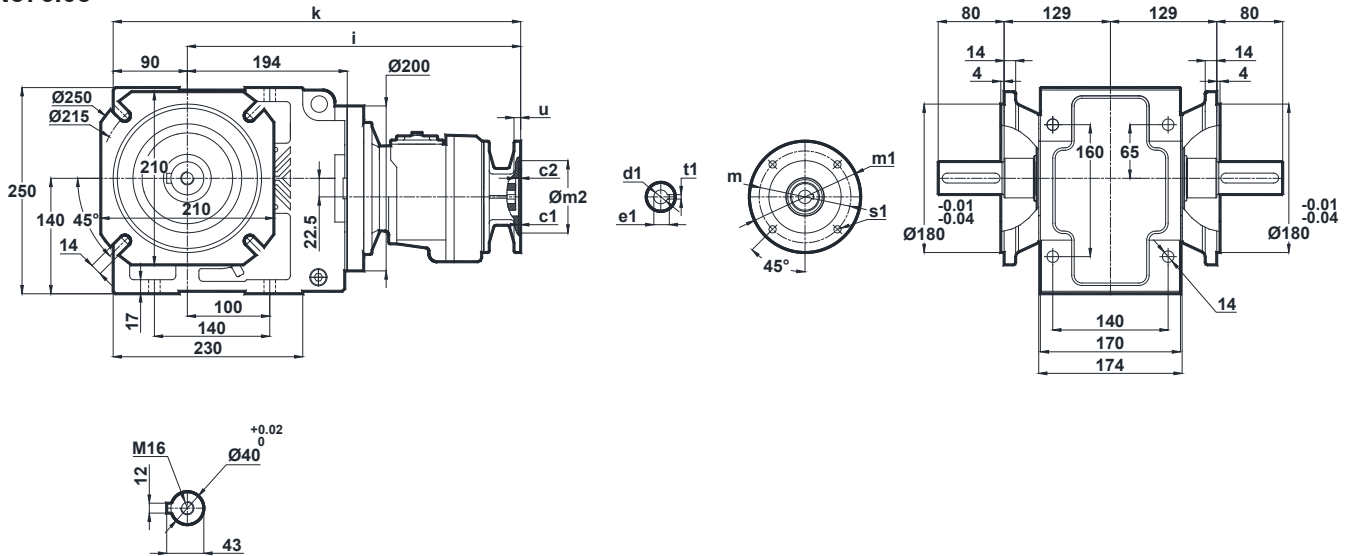

	c1	c2	s1	m	m1	m2	i	u	k	d1	t1	e1
63/B5	3.5	5	10	115	140	95	405	10	495	11	4	12.8
63/B14	2.5	5	5.5	75	90	60	405	10	495	11	4	12.8
71/B5	4	4.5	11	130	160	110	405	12	495	14	5	16.3
71/B14	3	4.5	7	85	105	70	405	10	495	14	5	16.3



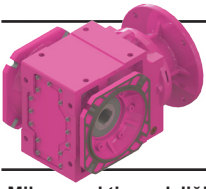

# Ölçü Sayfaları Dimension Pages Abmessungsseiten

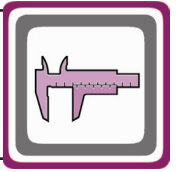

-Mil ucu çekirme deliği DIN 332 sayfa 2 / Tapped center hole to DIN 332, sheet 2 / Zentrierung mit Gewinde DIN 332, Blatt 2

KN375.08  
KN376.08

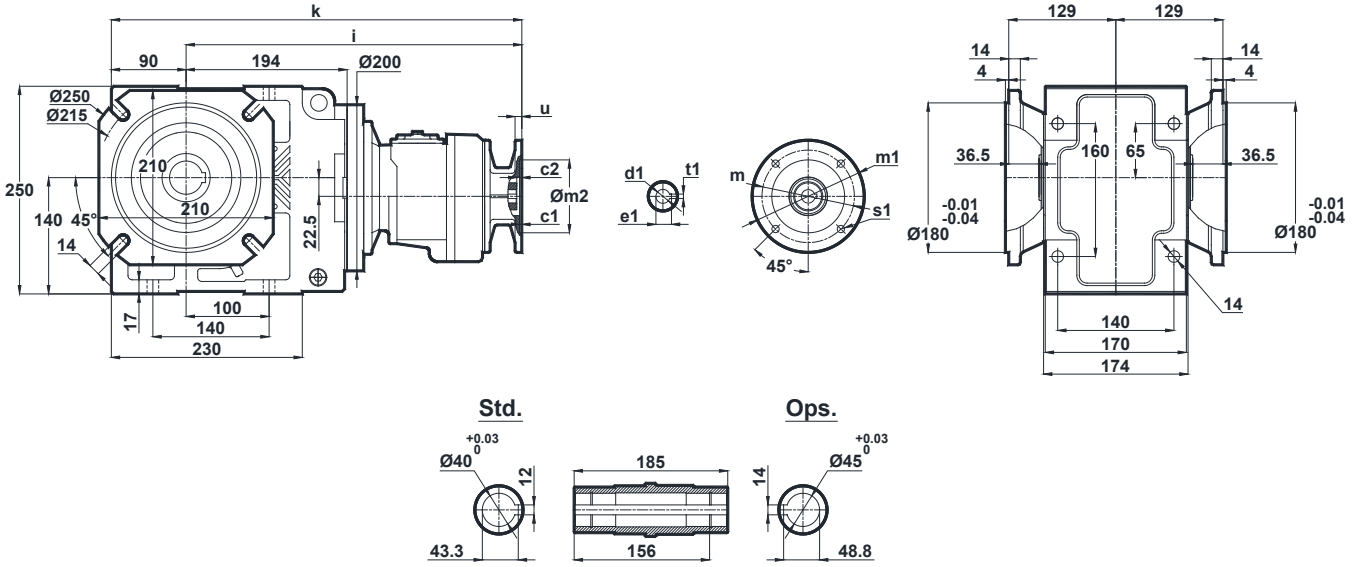

	c1	c2	s1	m	m1	m2	i	u	k	d1	t1	e1
63/B5	3.5	5	10	115	140	95	405	10	495	11	4	12.8
63/B14	2.5	5	5.5	75	90	60	405	10	495	11	4	12.8
71/B5	4	4.5	11	130	160	110	405	12	495	14	5	16.3
71/B14	3	4.5	7	85	105	70	405	10	495	14	5	16.3

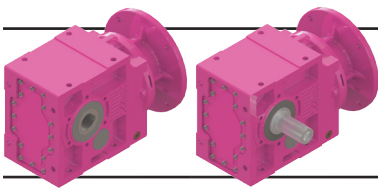

# Ölçü Sayfaları

## Dimension Pages

### Abmessungsseiten

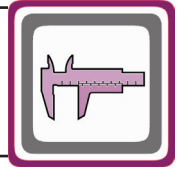

-Mil ucu çekirme deliği DIN 332 sayfa 2 / Tapped center hole to DIN 332, sheet 2 / Zentrierung mit Gewinde DIN 332, Blatt 2

#### KN473.00

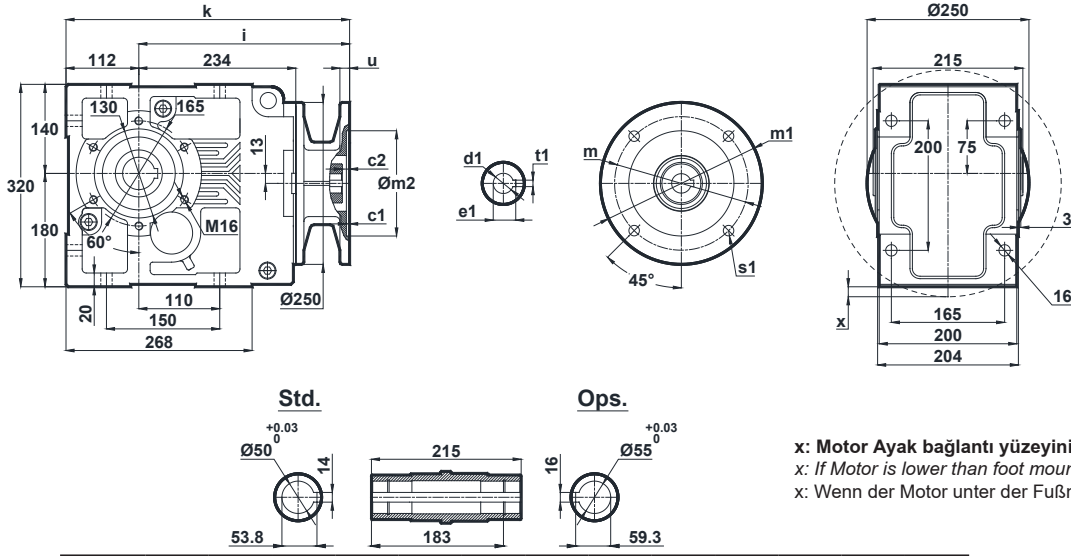

	c1	c2	s1	m	m1	m2	i	u	k	d1	t1	e1	x
80/B5	4	5	12	165	200	130	291	12	403	19	6	21.8	-
90/B5	4	5	12	165	200	130	291	12	403	24	8	27.3	-
90/B14	4	5	9	115	140	95	291	12	403	24	8	27.3	-
100/B5	4.5	9	15	215	250	180	309	15	421	28	8	31.3	-
100/B14	3.5	9	9	130	160	110	309	15	421	28	8	31.3	-
112/B5	4.5	9	15	215	250	180	309	15	421	28	8	31.3	-
112/B14	3.5	9	9	130	160	110	309	15	421	28	8	31.3	-
132/B5	4.5	6	15	265	300	230	328	15	440	38	10	41.3	-
132/B14	4.5	6	11	165	200	130	328	15	440	38	10	41.3	-
160/B5	5.5	10	19	300	350	250	407	20	519	42	12	45.3	8
180/B5	5.5	10	19	300	350	250	407	20	519	48	14	51.8	8

#### KN473.01

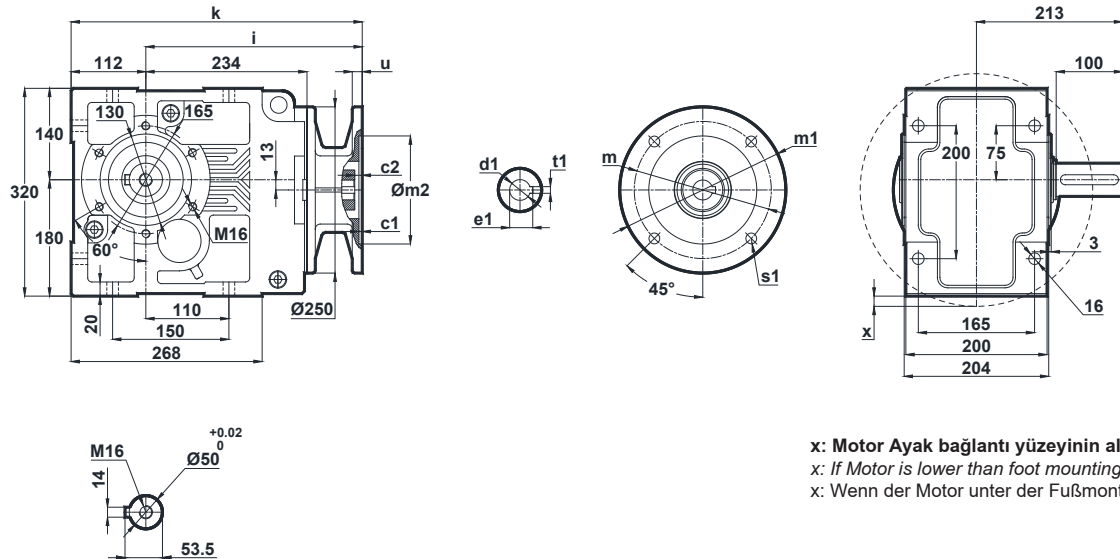

	c1	c2	s1	m	m1	m2	i	u	k	d1	t1	e1	x
80/B5	4	5	12	165	200	130	291	12	403	19	6	21.8	-
90/B5	4	5	12	165	200	130	291	12	403	24	8	27.3	-
90/B14	4	5	9	115	140	95	291	12	403	24	8	27.3	-
100/B5	4.5	9	15	215	250	180	309	15	421	28	8	31.3	-
100/B14	3.5	9	9	130	160	110	309	15	421	28	8	31.3	-
112/B5	4.5	9	15	215	250	180	309	15	421	28	8	31.3	-
112/B14	3.5	9	9	130	160	110	309	15	421	28	8	31.3	-
132/B5	4.5	6	15	265	300	230	328	15	440	38	10	41.3	-
132/B14	4.5	6	11	165	200	130	328	15	440	38	10	41.3	-
160/B5	5.5	10	19	300	350	250	407	20	519	42	12	45.3	8
180/B5	5.5	10	19	300	350	250	407	20	519	48	14	51.8	8

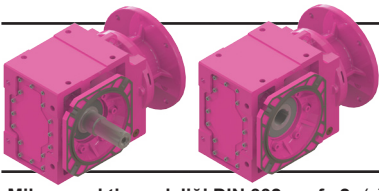

# Ölçü Sayfaları

## Dimension Pages

### Abmessungsseiten

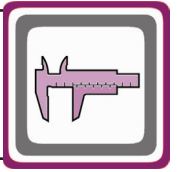

-Mil ucu çektirme deliği DIN 332 sayfa 2 / Tapped center hole to DIN 332, sheet 2 / Zentrierung mit Gewinde DIN 332, Blatt 2

#### KN473.02

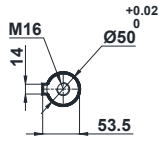
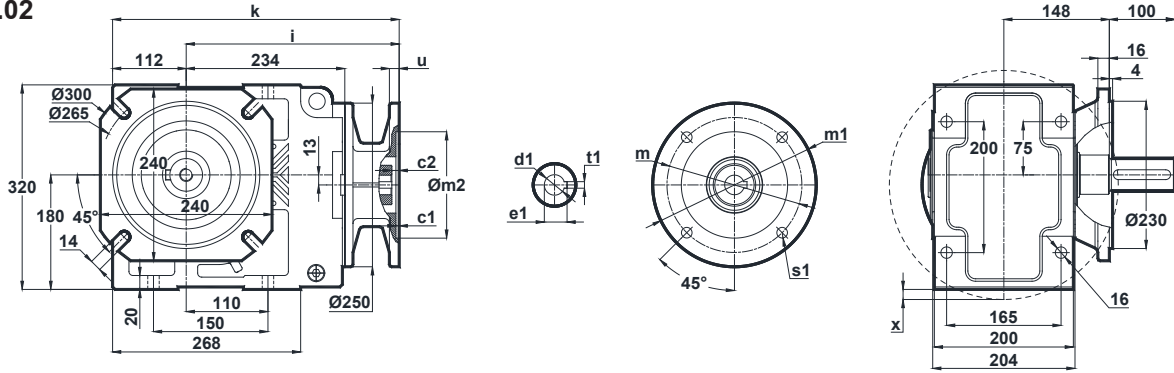

x: Motor Ayak bağlantı yüzeyinin altında ise  
x: If Motor is lower than foot mounting plane  
x: Wenn der Motor unter der Fußmontageebene ist

	c1	c2	s1	m	m1	m2	i	u	k	d1	t1	e1	x
80/B5	4	5	12	165	200	130	291	12	403	19	6	21.8	-
90/B5	4	5	12	165	200	130	291	12	403	24	8	27.3	-
90/B14	4	5	9	115	140	95	291	12	403	24	8	27.3	-
100/B5	4.5	9	15	215	250	180	309	15	421	28	8	31.3	-
100/B14	3.5	9	9	130	160	110	309	15	421	28	8	31.3	-
112/B5	4.5	9	15	215	250	180	309	15	421	28	8	31.3	-
112/B14	3.5	9	9	130	160	110	309	15	421	28	8	31.3	-
132/B5	4.5	6	15	265	300	230	328	15	440	38	10	41.3	-
132/B14	4.5	6	11	165	200	130	328	15	440	38	10	41.3	-
160/B5	5.5	10	19	300	350	250	407	20	519	42	12	45.3	8
180/B5	5.5	10	19	300	350	250	407	20	519	48	14	51.8	8

#### KN473.03

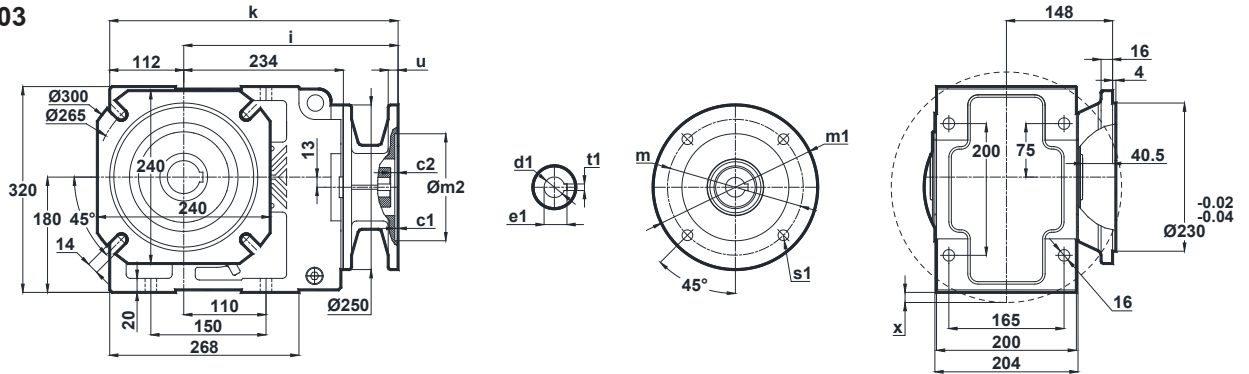

Std.

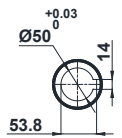

Ops.

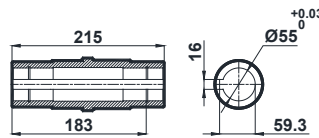

x: Motor Ayak bağlantı yüzeyinin altında ise  
x: If Motor is lower than foot mounting plane  
x: Wenn der Motor unter der Fußmontageebene ist

	c1	c2	s1	m	m1	m2	i	u	k	d1	t1	e1	x
80/B5	4	5	12	165	200	130	291	12	403	19	6	21.8	-
90/B5	4	5	12	165	200	130	291	12	403	24	8	27.3	-
90/B14	4	5	9	115	140	95	291	12	403	24	8	27.3	-
100/B5	4.5	9	15	215	250	180	309	15	421	28	8	31.3	-
100/B14	3.5	9	9	130	160	110	309	15	421	28	8	31.3	-
112/B5	4.5	9	15	215	250	180	309	15	421	28	8	31.3	-
112/B14	3.5	9	9	130	160	110	309	15	421	28	8	31.3	-
132/B5	4.5	6	15	265	300	230	328	15	440	38	10	41.3	-
132/B14	4.5	6	11	165	200	130	328	15	440	38	10	41.3	-
160/B5	5.5	10	19	300	350	250	407	20	519	42	12	45.3	8
180/B5	5.5	10	19	300	350	250	407	20	519	48	14	51.8	8

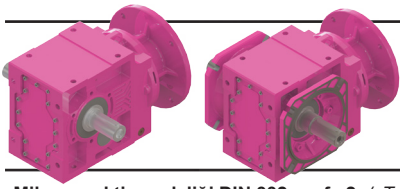

# Ölçü Sayfaları

## Dimension Pages

### Abmessungsseiten

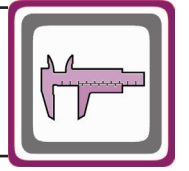

-Mil ucu çekirme deliği DIN 332 sayfa 2 / Tapped center hole to DIN 332, sheet 2 / Zentrierung mit Gewinde DIN 332, Blatt 2

#### KN473.04

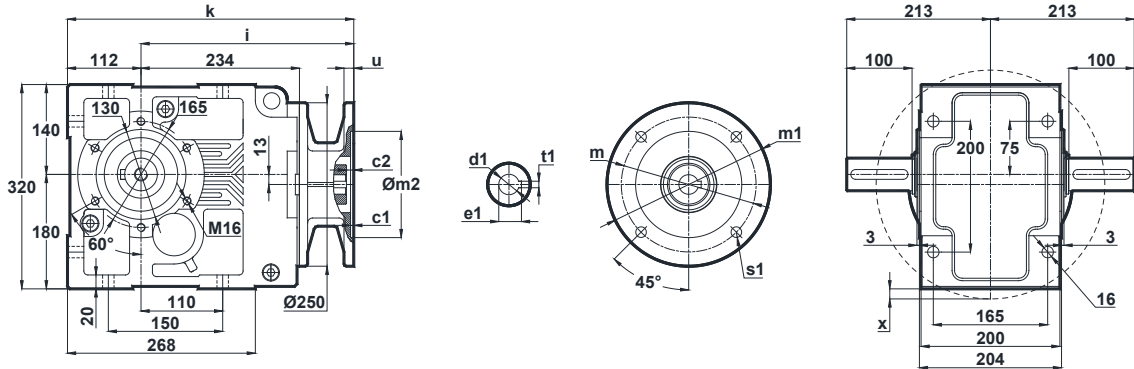

x: Motor Ayak bağlantı yüzeyinin altında ise  
x: If Motor is lower than foot mounting plane  
x: Wenn der Motor unter der Fußmontageebene ist

	c1	c2	s1	m	m1	m2	i	u	k	d1	t1	e1	x
80/B5	4	5	12	165	200	130	291	12	403	19	6	21.8	-
90/B5 90/B14	4	5	12 9	165 115	200 140	130 95	291	12	403	24	8	27.3	-
100/B5 100/B14	4.5 3.5	9	15 9	215 130	250 160	180 110	309	15	421	28	8	31.3	-
112/B5 112/B14	4.5 3.5	9	15 9	215 130	250 160	180 110	309	15	421	28	8	31.3	-
132/B5 132/B14	4.5	6	15 11	265 165	300 200	230 130	328	15	440	38	10	41.3	-
160/B5	5.5	10	19	300	350	250	407	20	519	42	12	45.3	8
180/B5	5.5	10	19	300	350	250	407	20	519	48	14	51.8	8

#### KN473.05

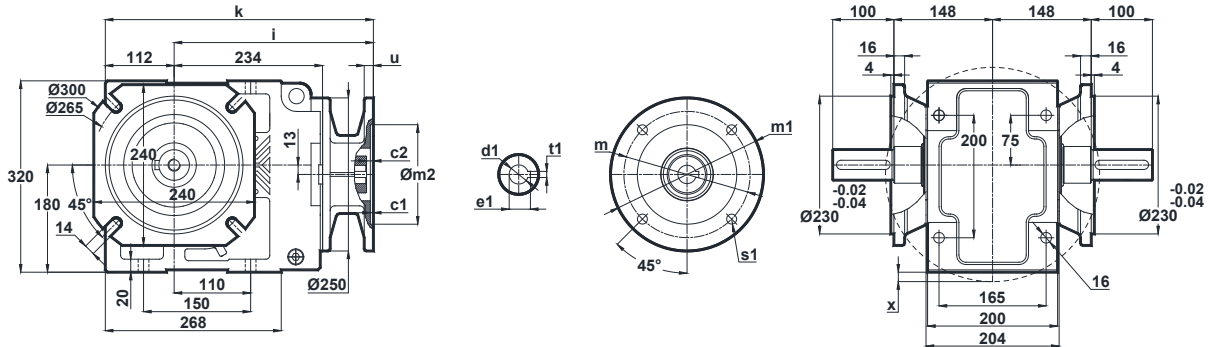

x: Motor Ayak bağlantı yüzeyinin altında ise  
x: If Motor is lower than foot mounting plane  
x: Wenn der Motor unter der Fußmontageebene ist

	c1	c2	s1	m	m1	m2	i	u	k	d1	t1	e1	x
80/B5	4	5	12	165	200	130	291	12	403	19	6	21.8	-
90/B5 90/B14	4	5	12 9	165 115	200 140	130 95	291	12	403	24	8	27.3	-
100/B5 100/B14	4.5 3.5	9	15 9	215 130	250 160	180 110	309	15	421	28	8	31.3	-
112/B5 112/B14	4.5 3.5	9	15 9	215 130	250 160	180 110	309	15	421	28	8	31.3	-
132/B5 132/B14	4.5	6	15 11	265 165	300 200	230 130	328	15	440	38	10	41.3	-
160/B5	5.5	10	19	300	350	250	407	20	519	42	12	45.3	8
180/B5	5.5	10	19	300	350	250	407	20	519	48	14	51.8	8

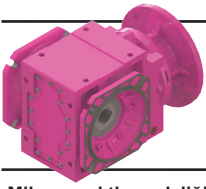

# Ölçü Sayfaları Dimension Pages Abmessungsseiten

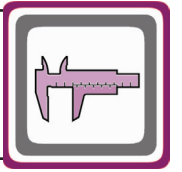

-Mil ucu çekirme deliği DIN 332 sayfa 2 / Tapped center hole to DIN 332, sheet 2 / Zentrierung mit Gewinde DIN 332, Blatt 2

KN473.08

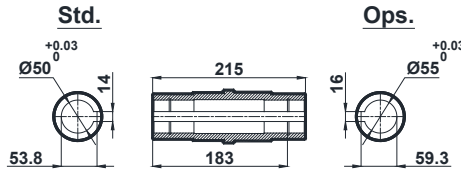
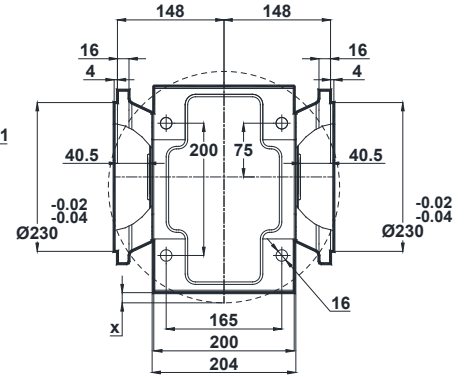
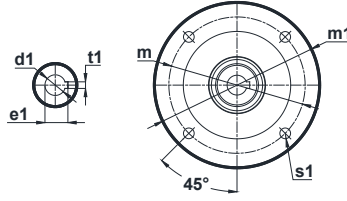
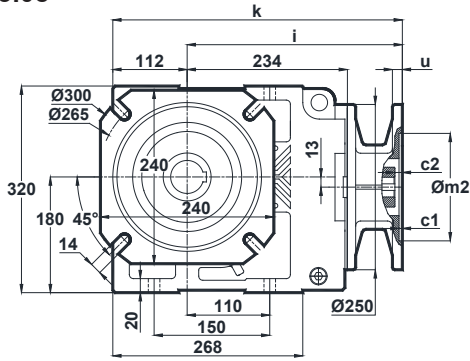

x: Motor Ayak bağlantı yüzeyinin altında ise  
x: If Motor is lower than foot mounting plane  
x: Wenn der Motor unter der Fußmontageebene ist

	c1	c2	s1	m	m1	m2	i	u	k	d1	t1	e1	x
80/B5	4	5	12	165	200	130	291	12	403	19	6	21.8	-
90/B5	4	5	12	165	200	130	291	12	403	24	8	27.3	-
90/B14	4	5	9	115	140	95	291	12	403	24	8	27.3	-
100/B5	4.5	9	15	215	250	180	309	15	421	28	8	31.3	-
100/B14	3.5	9	9	130	160	110	309	15	421	28	8	31.3	-
112/B5	4.5	9	15	215	250	180	309	15	421	28	8	31.3	-
112/B14	3.5	9	9	130	160	110	309	15	421	28	8	31.3	-
132/B5	4.5	6	15	265	300	230	328	15	440	38	10	41.3	-
132/B14	4.5	6	11	165	200	130	328	15	440	38	10	41.3	-
160/B5	5.5	10	19	300	350	250	407	20	519	42	12	45.3	8
180/B5	5.5	10	19	300	350	250	407	20	519	48	14	51.8	8

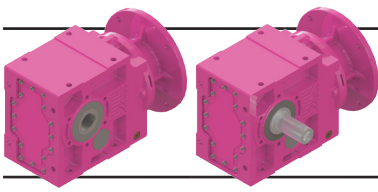

# Ölçü Sayfaları

## Dimension Pages

### Abmessungsseiten

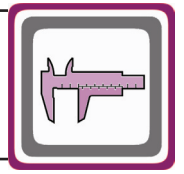

-Mil ucu çekirme deliği DIN 332 sayfa 2 / Tapped center hole to DIN 332, sheet 2 / Zentrierung mit Gewinde DIN 332, Blatt 2

#### KN474.00

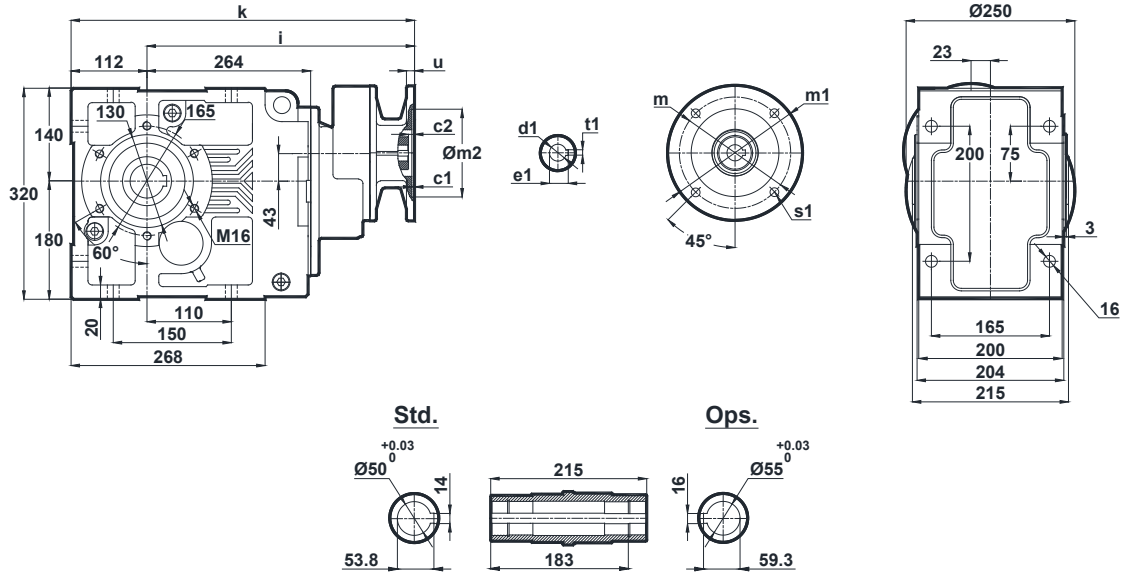

	c1	c2	s1	m	m1	m2	i	u	k	d1	t1	e1
71/B5	4	9	11	130	160	110	389	12	501	14	5	16.3
80/B5 80/B14	4	9	12 7	165 100	200 120	130 80	389	12	501	19	6	21.8

#### KN474.01

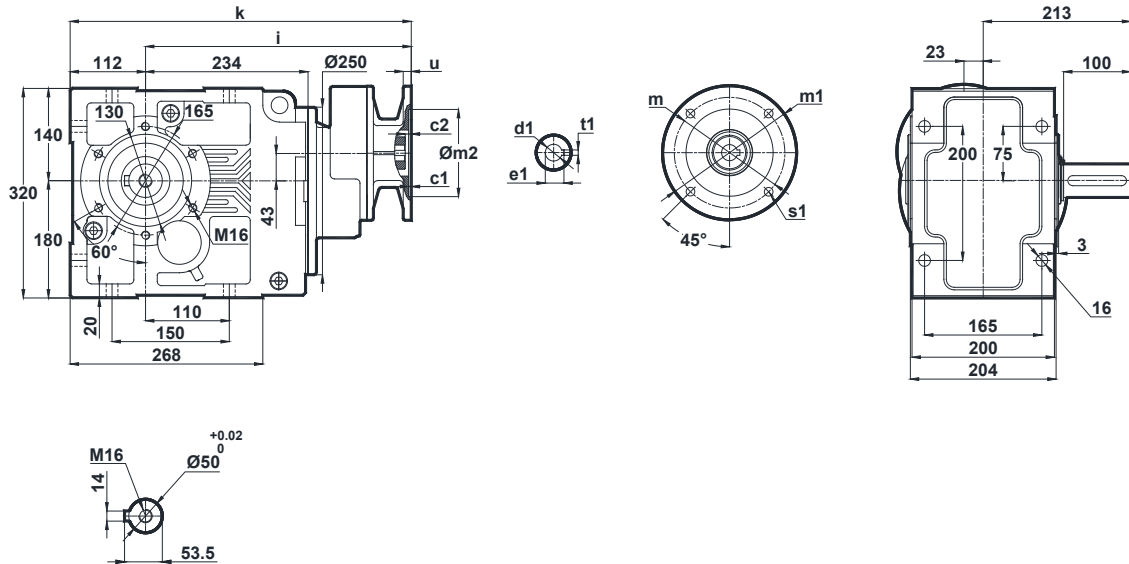

	c1	c2	s1	m	m1	m2	i	u	k	d1	t1	e1
71/B5	4	9	11	130	160	110	389	12	501	14	5	16.3
80/B5 80/B14	4	9	12 7	165 100	200 120	130 80	389	12	501	19	6	21.8

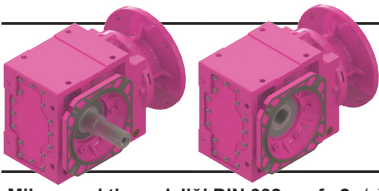

# Ölçü Sayfaları

## Dimension Pages

### Abmessungsseiten

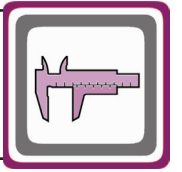

-Mil ucu çekirme deliği DIN 332 sayfa 2 / Tapped center hole to DIN 332, sheet 2 / Zentrierung mit Gewinde DIN 332, Blatt 2

#### KN474.02

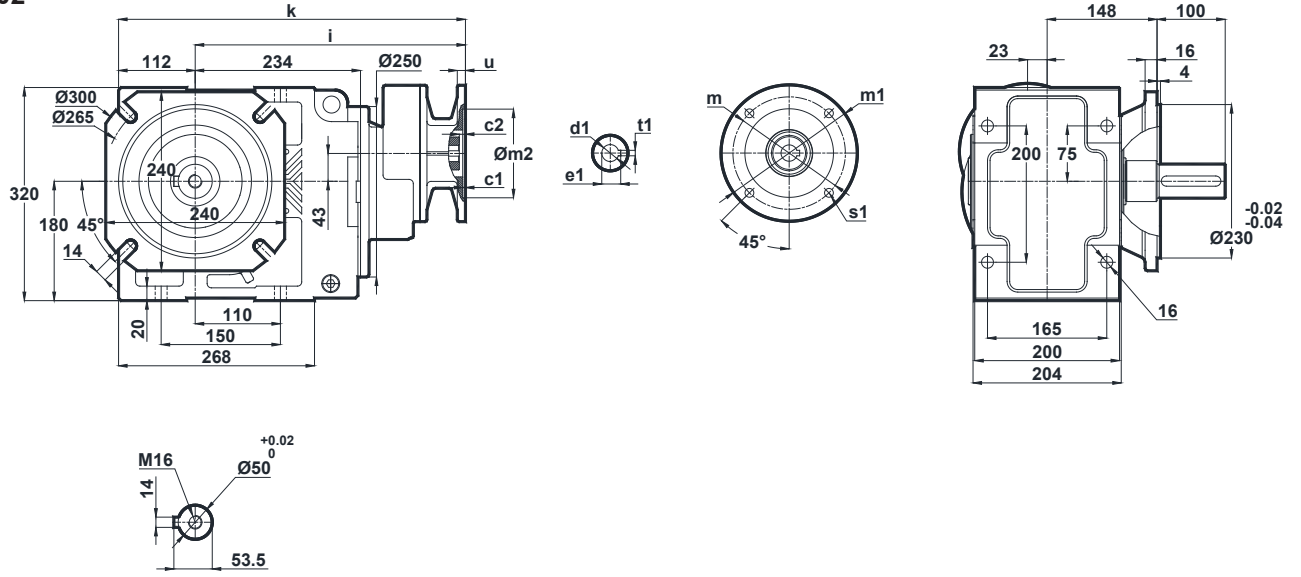

	c1	c2	s1	m	m1	m2	i	u	k	d1	t1	e1
71/B5	4	9	11	130	160	110	389	12	501	14	5	16.3
80/B5 80/B14	4	9	12 7	165 100	200 120	130 80	389	12	501	19	6	21.8

#### KN474.03

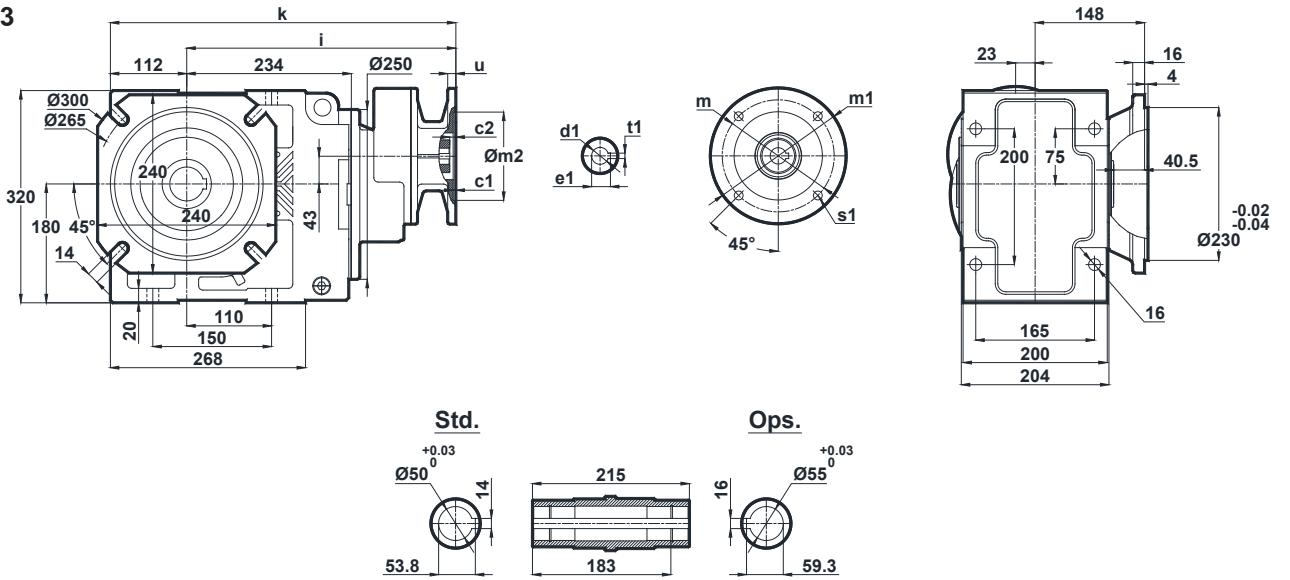

	c1	c2	s1	m	m1	m2	i	u	k	d1	t1	e1
71/B5	4	9	11	130	160	110	389	12	501	14	5	16.3
80/B5 80/B14	4	9	12 7	165 100	200 120	130 80	389	12	501	19	6	21.8

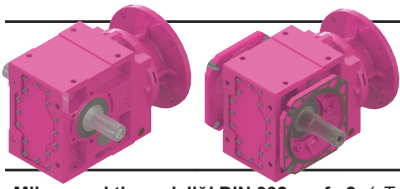

# Ölçü Sayfaları

## Dimension Pages

### Abmessungsseiten

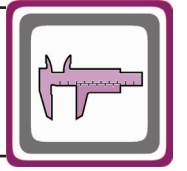

-Mil ucu çektirme deliği DIN 332 sayfa 2 / Tapped center hole to DIN 332, sheet 2 / Zentrierung mit Gewinde DIN 332, Blatt 2

#### KN474.04

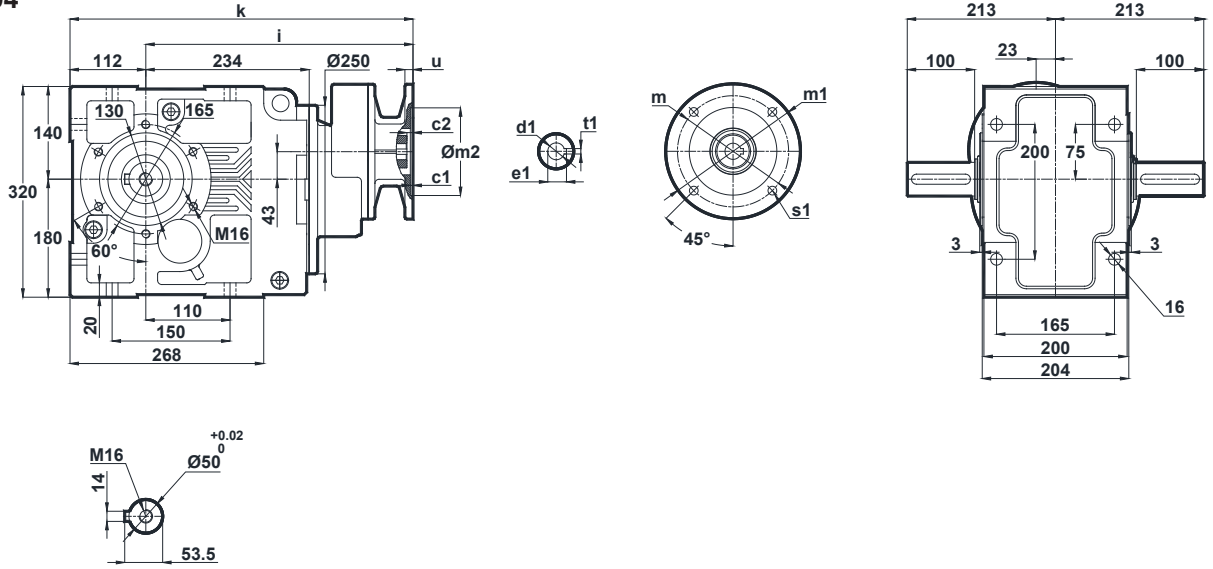

	c1	c2	s1	m	m1	m2	i	u	k	d1	t1	e1
71/B5	4	9	11	130	160	110	389	12	501	14	5	16.3
80/B5 80/B14	4	9	12 7	165 100	200 120	130 80	389	12	501	19	6	21.8

#### KN474.05

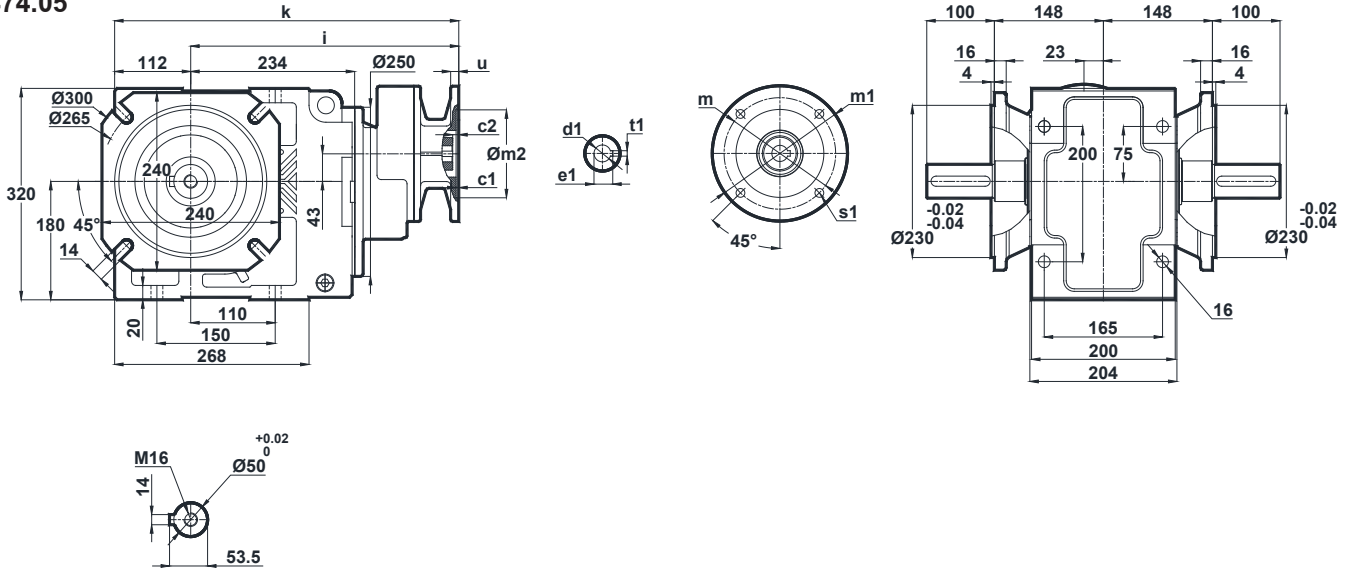

	c1	c2	s1	m	m1	m2	i	u	k	d1	t1	e1
71/B5	4	9	11	130	160	110	389	12	501	14	5	16.3
80/B5 80/B14	4	9	12 7	165 100	200 120	130 80	389	12	501	19	6	21.8



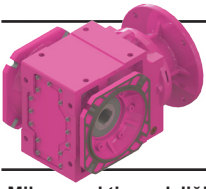

# Ölçü Sayfaları Dimension Pages Abmessungsseiten

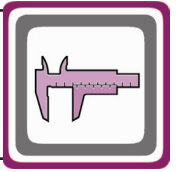

-Mil ucu çekirme deliği DIN 332 sayfa 2 / Tapped center hole to DIN 332, sheet 2 / Zentrierung mit Gewinde DIN 332, Blatt 2

KN474.08

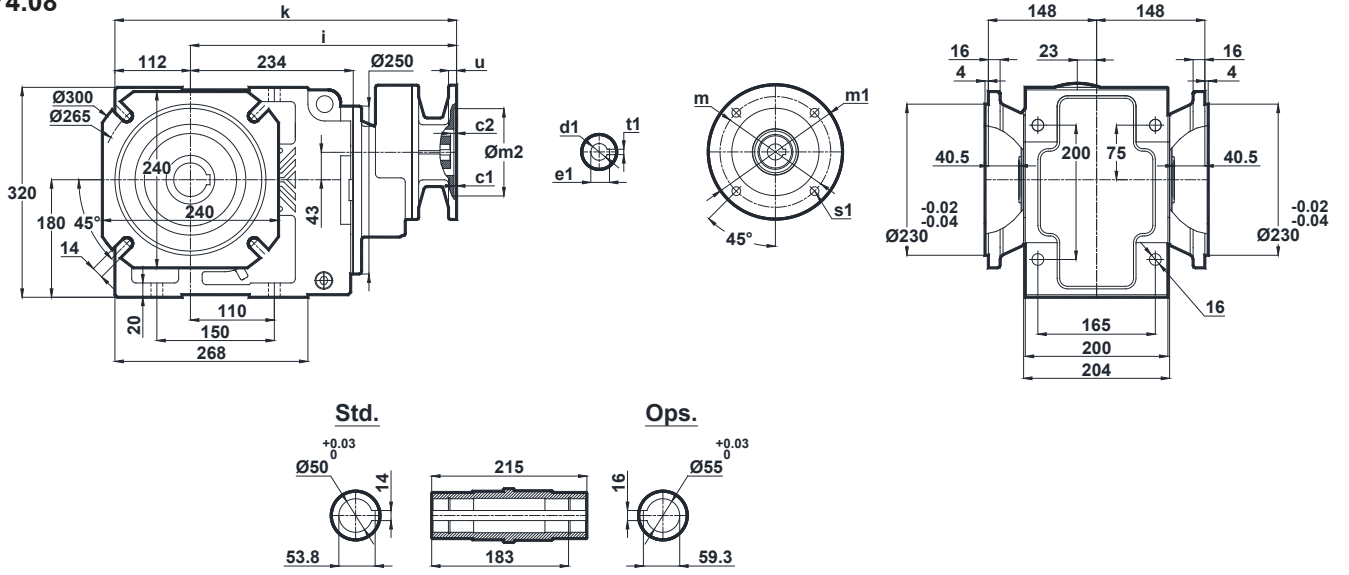

	c1	c2	s1	m	m1	m2	i	u	k	d1	t1	e1
71/B5	4	9	11	130	160	110	389	12	501	14	5	16.3
80/B5 80/B14	4	9	12 7	165 100	200 120	130 80	389	12	501	19	6	21.8

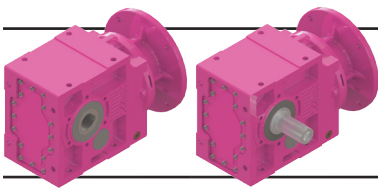

# Ölçü Sayfaları

## Dimension Pages

### Abmessungsseiten

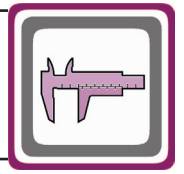

-Mil ucu çekirme deliği DIN 332 sayfa 2 / Tapped center hole to DIN 332, sheet 2 / Zentrierung mit Gewinde DIN 332, Blatt 2

KN475.00  
KN476.00

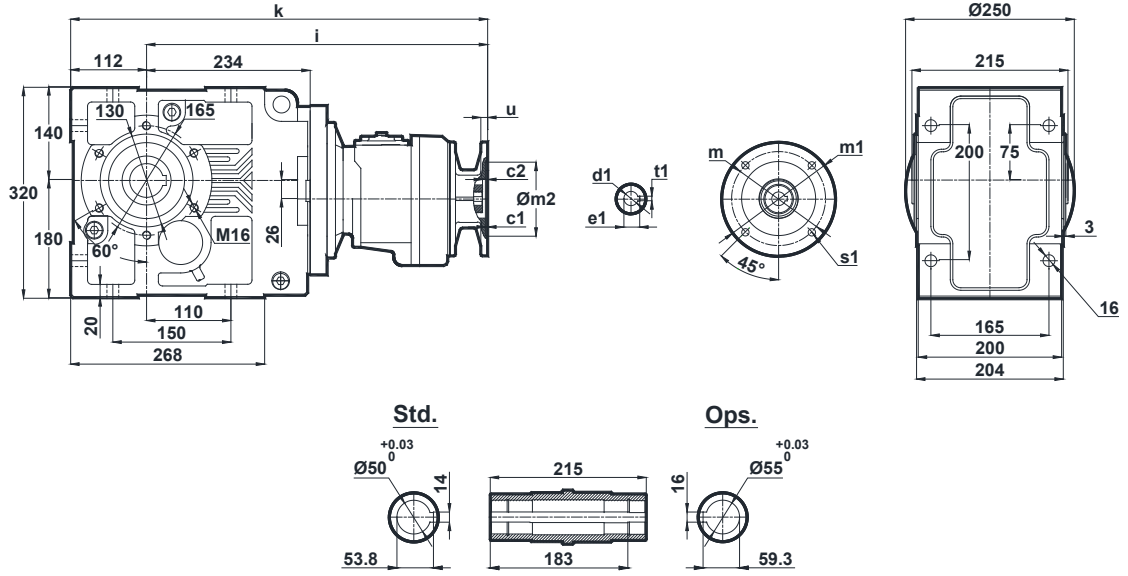

	c1	c2	s1	m	m1	m2	i	u	k	d1	t1	e1
63/B5	3.5	8	9	115	140	95	517	12	629	11	4	12.8
71/B5	4	8.5	11	130	160	110	488	12	600	14	5	16.3
71/B14	3		7	85	105	70		10				

KN475.01  
KN476.01

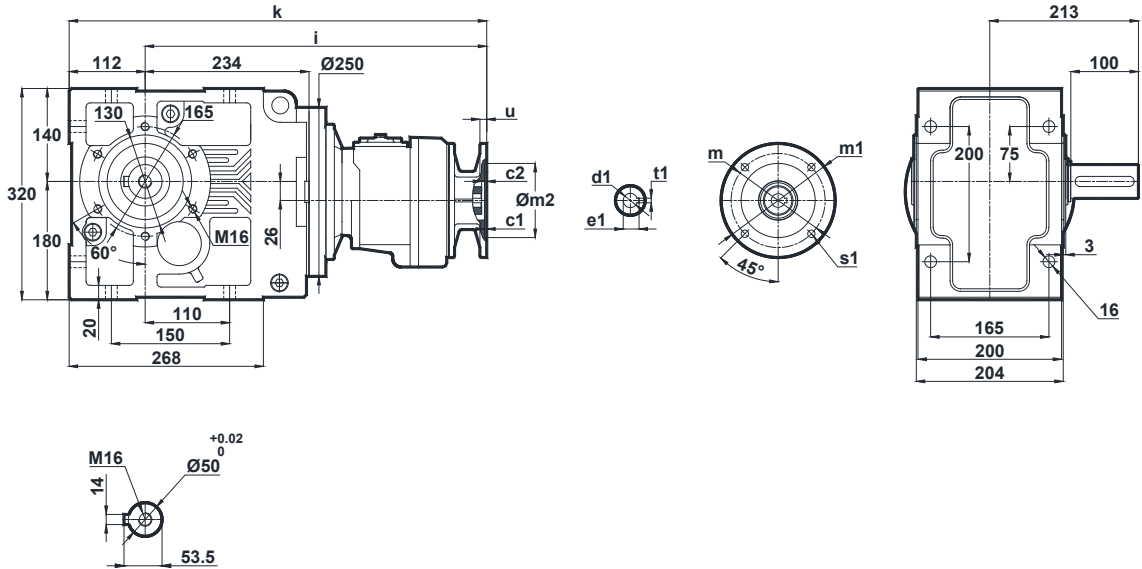

	c1	c2	s1	m	m1	m2	i	u	k	d1	t1	e1
63/B5	3.5	8	9	115	140	95	517	12	629	11	4	12.8
71/B5	4	8.5	11	130	160	110	488	12	600	14	5	16.3
71/B14	3		7	85	105	70		10				

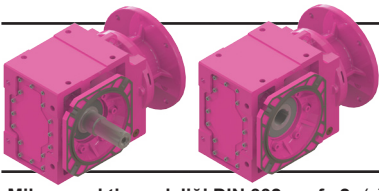

# Ölçü Sayfaları

## Dimension Pages

### Abmessungsseiten

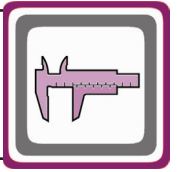

-Mil ucu çekirme deliği DIN 332 sayfa 2 / Tapped center hole to DIN 332, sheet 2 / Zentrierung mit Gewinde DIN 332, Blatt 2

KN475.02  
KN476.02

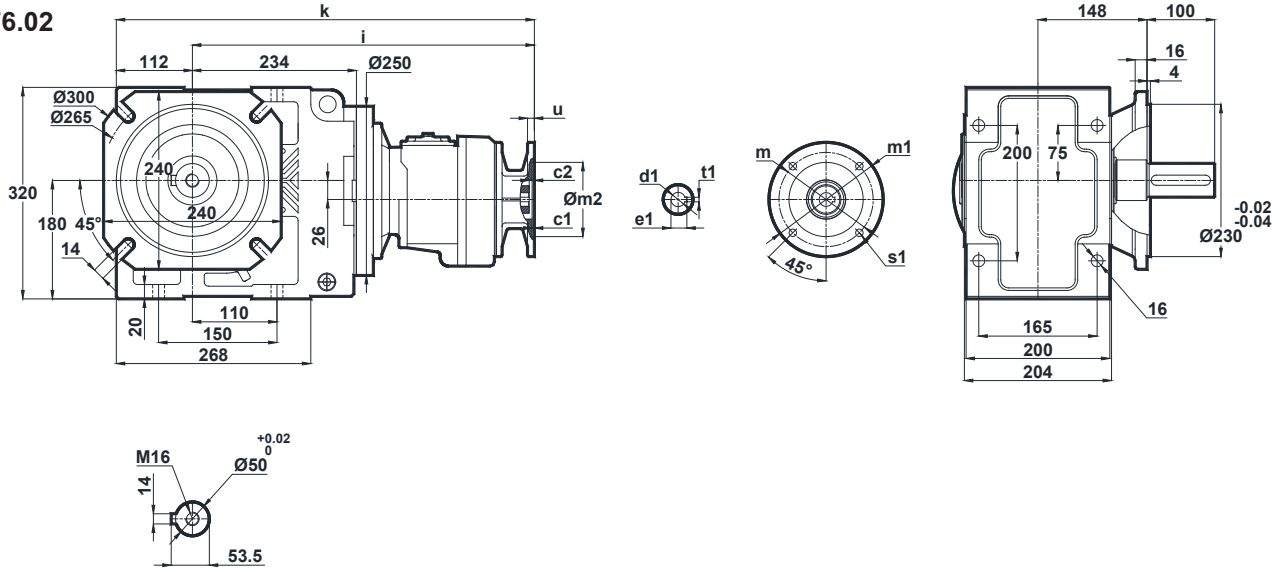

	c1	c2	s1	m	m1	m2	i	u	k	d1	t1	e1
63/B5	3.5	8	9	115	140	95	517	12	629	11	4	12.8
71/B5 71/B14	4 3	8.5	11 7	130 85	160 105	110 70	488	12 10	600	14	5	16.3

KN475.03  
KN476.03

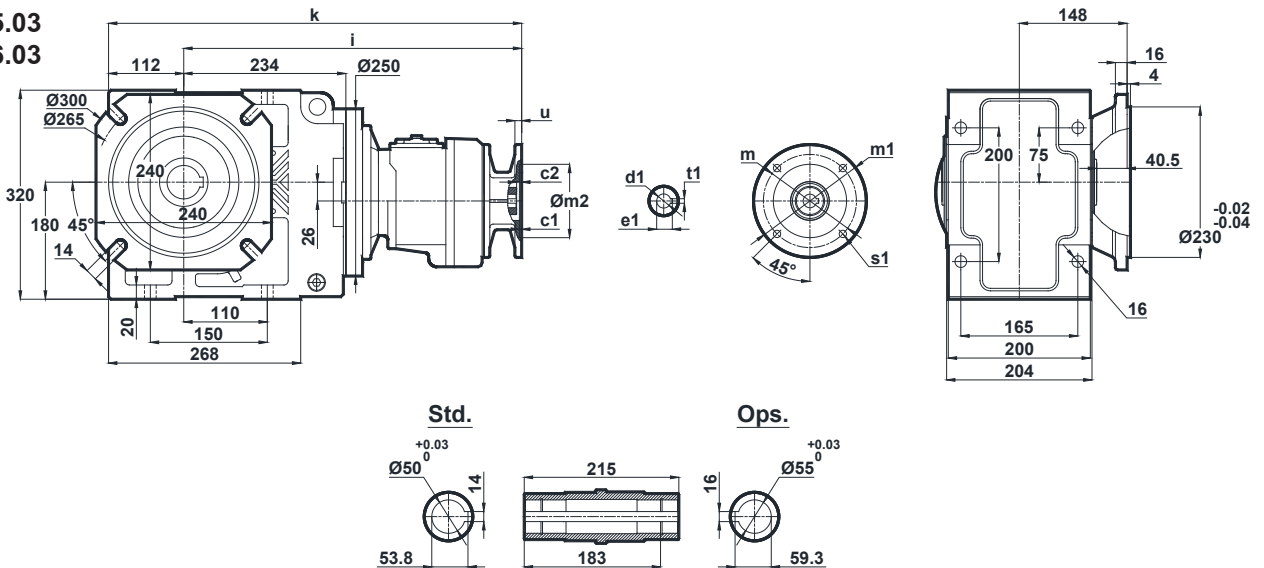

	c1	c2	s1	m	m1	m2	i	u	k	d1	t1	e1
63/B5	3.5	8	9	115	140	95	517	12	629	11	4	12.8
71/B5 71/B14	4 3	8.5	11 7	130 85	160 105	110 70	488	12 10	600	14	5	16.3

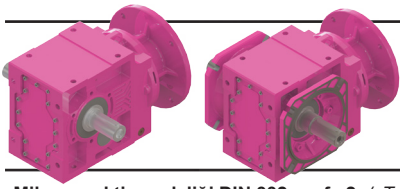

# Ölçü Sayfaları

## Dimension Pages

### Abmessungsseiten

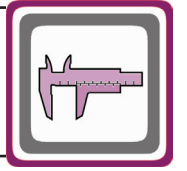

-Mil ucu çektirme deliği DIN 332 sayfa 2 / Tapped center hole to DIN 332, sheet 2 / Zentrierung mit Gewinde DIN 332, Blatt 2

KN475.04  
KN476.04

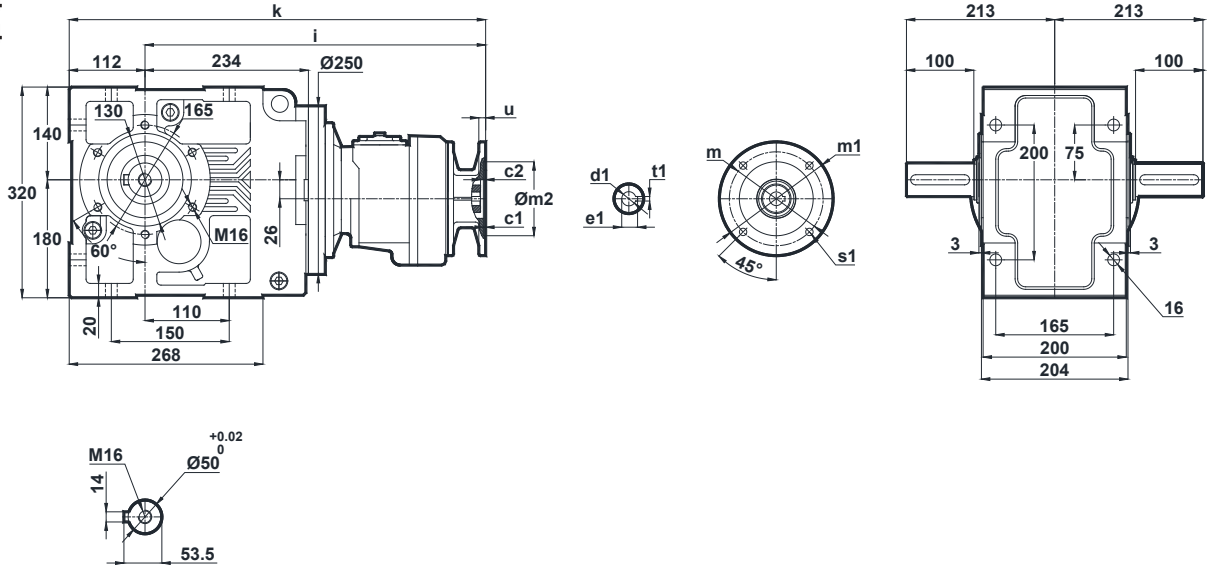

	c1	c2	s1	m	m1	m2	i	u	k	d1	t1	e1
63/B5	3.5	8	9	115	140	95	517	12	629	11	4	12.8
71/B5	4	8.5	11	130	160	110	488	12	600	14	5	16.3
71/B14	3		7	85	105	70		10				

KN475.05  
KN476.05

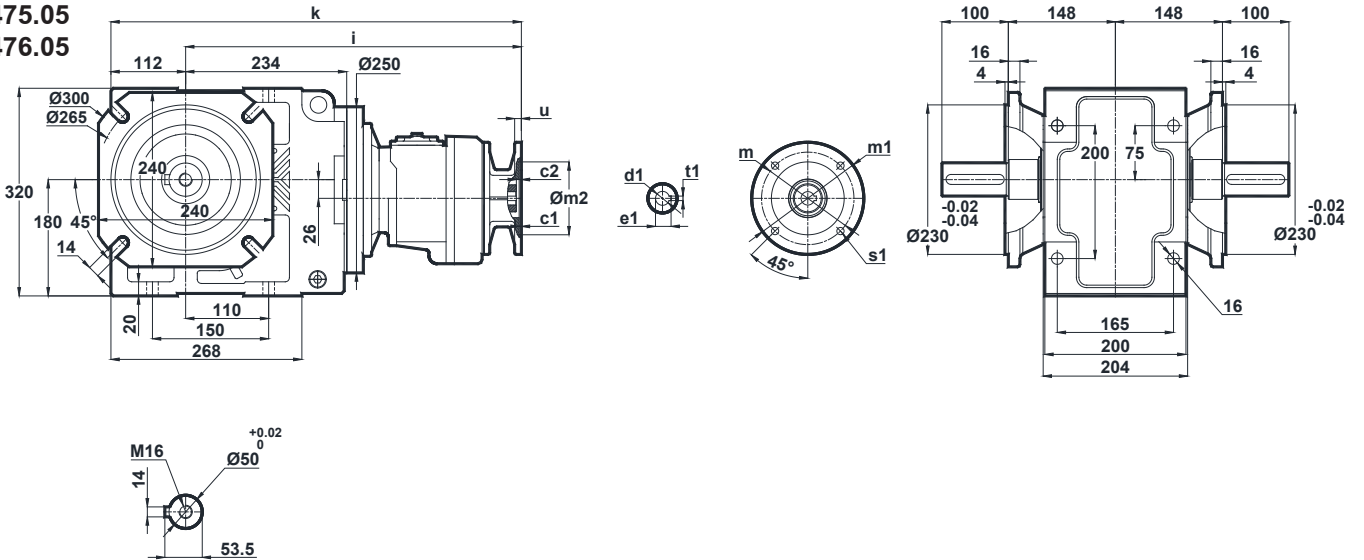

	c1	c2	s1	m	m1	m2	i	u	k	d1	t1	e1
63/B5	3.5	8	9	115	140	95	517	12	629	11	4	12.8
71/B5	4	8.5	11	130	160	110	488	12	600	14	5	16.3
71/B14	3		7	85	105	70		10				

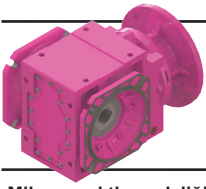

# Ölçü Sayfaları Dimension Pages Abmessungsseiten

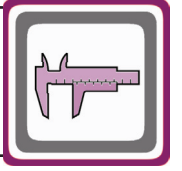

-Mil ucu çekirme deliği DIN 332 sayfa 2 / Tapped center hole to DIN 332, sheet 2 / Zentrierung mit Gewinde DIN 332, Blatt 2

KN475.08  
KN476.08

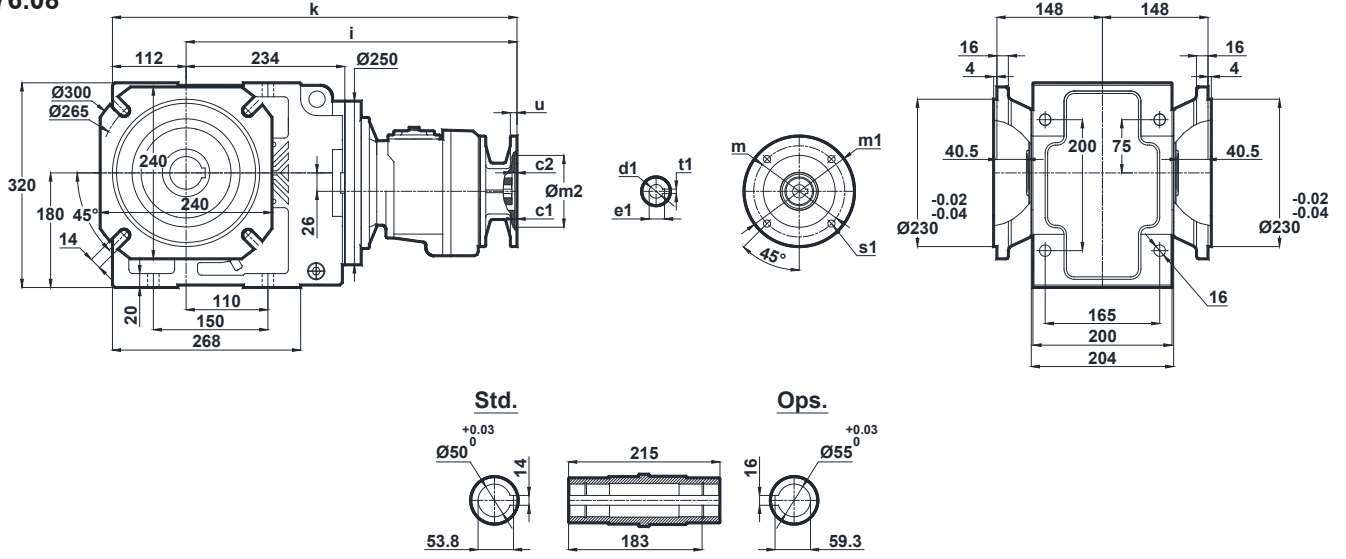

	c1	c2	s1	m	m1	m2	i	u	k	d1	t1	e1
63/B5	3.5	8	9	115	140	95	517	12	629	11	4	12.8
71/B5 71/B14	4 3	8.5	11 7	130 85	160 105	110 70	488	12 10	600	14	5	16.3

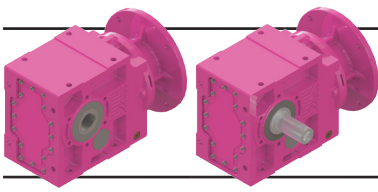

# Ölçü Sayfaları

## Dimension Pages

### Abmessungsseiten

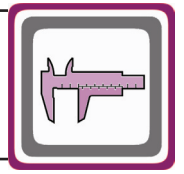

-Mil ucu çekirme deliği DIN 332 sayfa 2 / Tapped center hole to DIN 332, sheet 2 / Zentrierung mit Gewinde DIN 332, Blatt 2

#### KN573.00

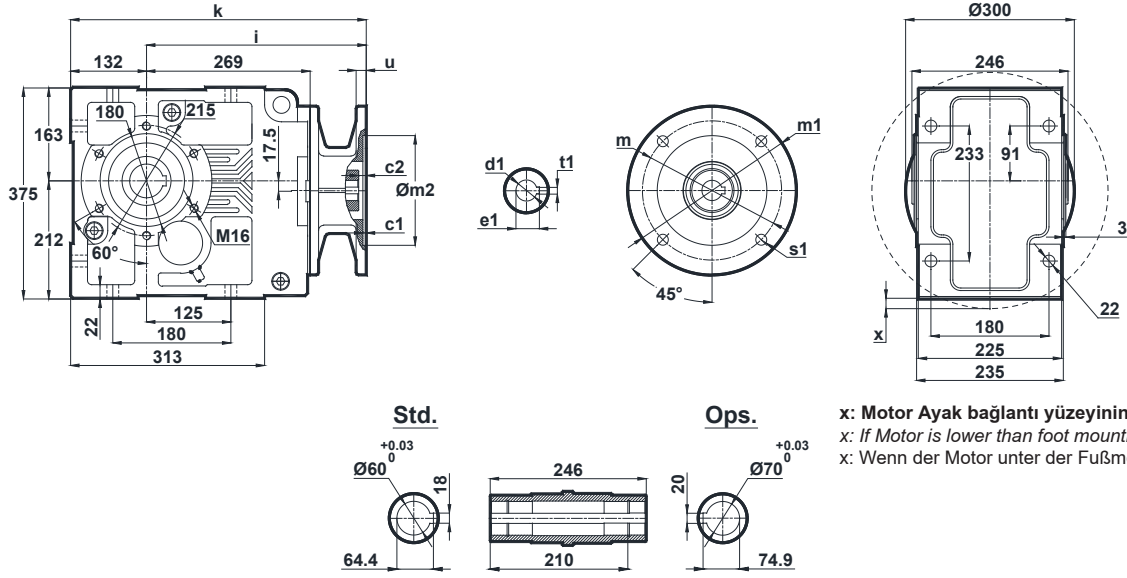

x: Motor Ayak bağlantı yüzeyinin altında ise  
x: If Motor is lower than foot mounting plane  
x: Wenn der Motor unter der Fußmontageebene ist

	c1	c2	s1	m	m1	m2	i	u	k	d1	t1	e1	x
100/B5	4.5	20	15	215	250	180	342	15	474	28	8	31.3	-
112/B5	4.5	20	15	215	250	180	342	15	474	28	8	31.3	-
132/B5 132/B14	4.5	9	15 11	265 165	300 200	230 130	363	15	495	38	10	41.3	-
160/B5	5.5	10	19	300	350	250	438	18	570	42	12	45.3	-
180/B5	5.5	10	19	300	350	250	438	18	570	48	14	51.8	-

#### KN573.01

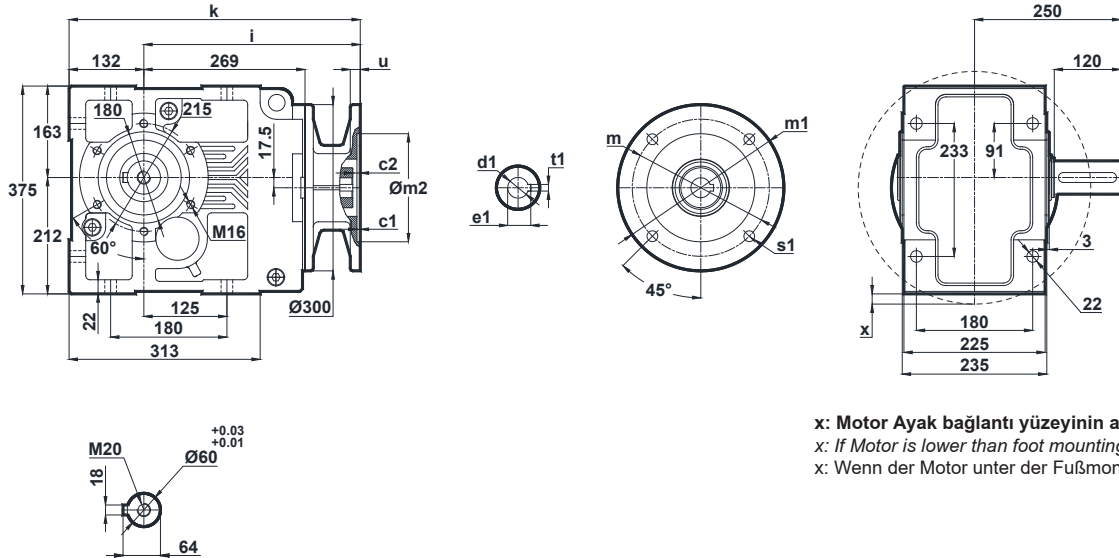

x: Motor Ayak bağlantı yüzeyinin altında ise  
x: If Motor is lower than foot mounting plane  
x: Wenn der Motor unter der Fußmontageebene ist

	c1	c2	s1	m	m1	m2	i	u	k	d1	t1	e1	x
100/B5	4.5	20	15	215	250	180	342	15	474	28	8	31.3	-
112/B5	4.5	20	15	215	250	180	342	15	474	28	8	31.3	-
132/B5 132/B14	4.5	9	15 11	265 165	300 200	230 130	363	15	495	38	10	41.3	-
160/B5	5.5	10	19	300	350	250	438	18	570	42	12	45.3	-
180/B5	5.5	10	19	300	350	250	438	18	570	48	14	51.8	-

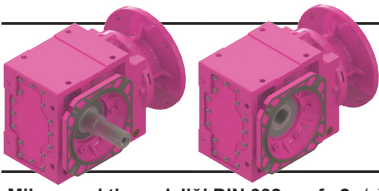

# Ölçü Sayfaları

## Dimension Pages

### Abmessungsseiten

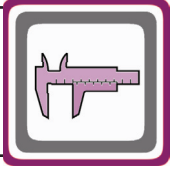

-Mil ucu çekirme deliği DIN 332 sayfa 2 / Tapped center hole to DIN 332, sheet 2 / Zentrierung mit Gewinde DIN 332, Blatt 2

#### KN573.02

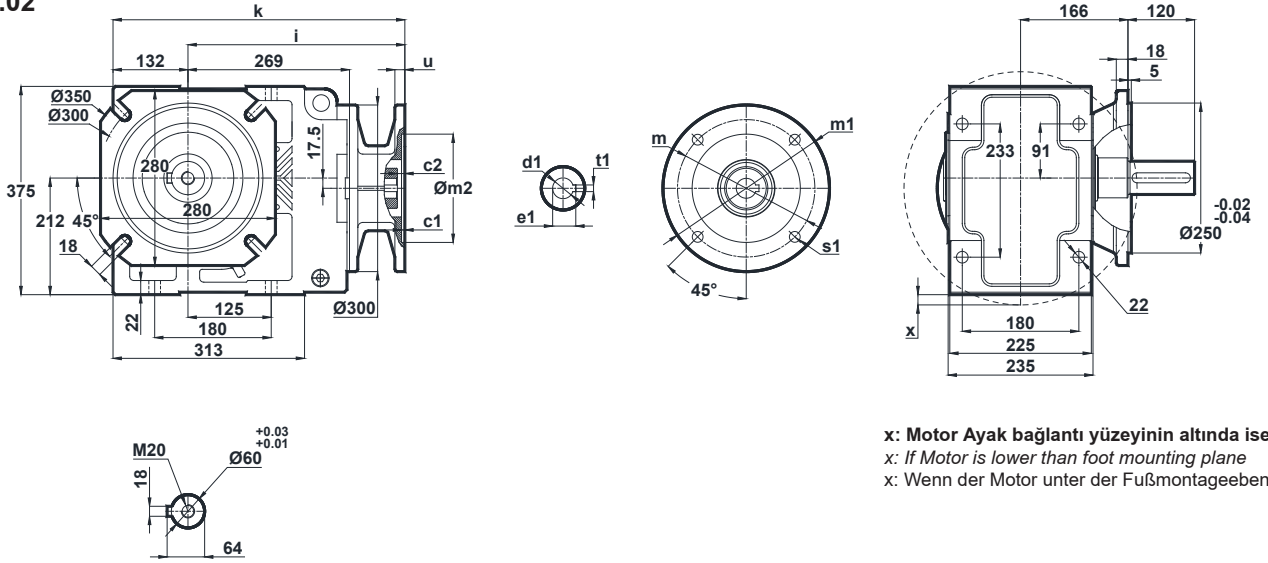

	c1	c2	s1	m	m1	m2	i	u	k	d1	t1	e1	x
100/B5	4.5	20	15	215	250	180	342	15	474	28	8	31.3	-
112/B5	4.5	20	15	215	250	180	342	15	474	28	8	31.3	-
132/B5 132/B14	4.5	9	15 11	265 165	300 200	230 130	363	15	495	38	10	41.3	-
160/B5	5.5	10	19	300	350	250	438	18	570	42	12	45.3	-
180/B5	5.5	10	19	300	350	250	438	18	570	48	14	51.8	-

#### KN573.03

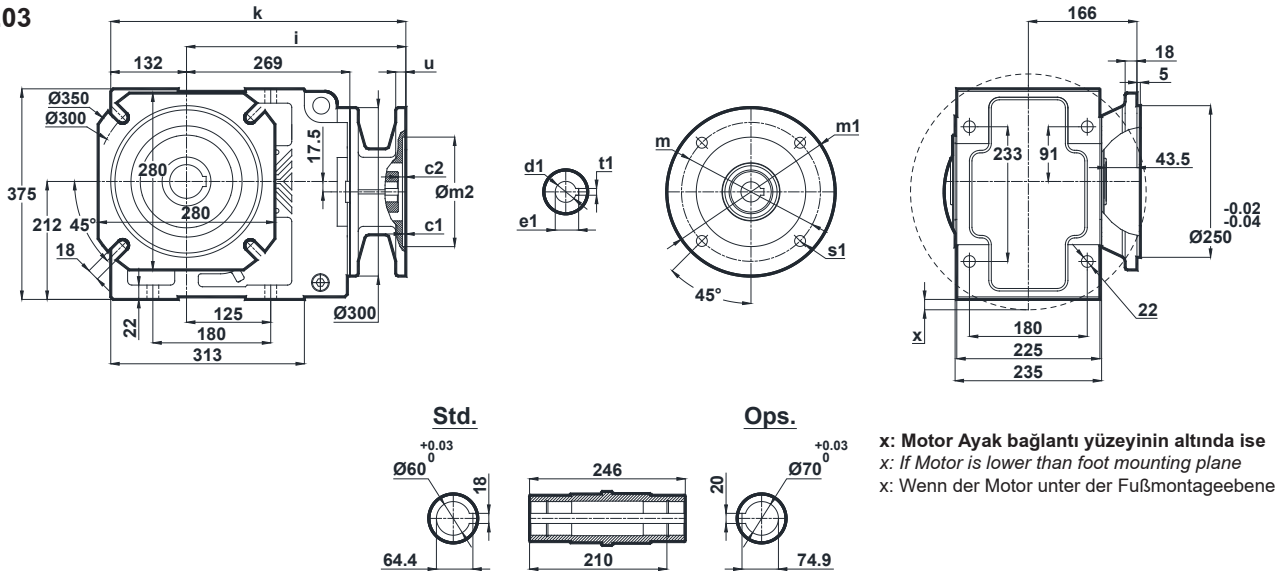

	c1	c2	s1	m	m1	m2	i	u	k	d1	t1	e1	x
100/B5	4.5	20	15	215	250	180	342	15	474	28	8	31.3	-
112/B5	4.5	20	15	215	250	180	342	15	474	28	8	31.3	-
132/B5 132/B14	4.5	9	15 11	265 165	300 200	230 130	363	15	495	38	10	41.3	-
160/B5	5.5	10	19	300	350	250	438	18	570	42	12	45.3	-
180/B5	5.5	10	19	300	350	250	438	18	570	48	14	51.8	-

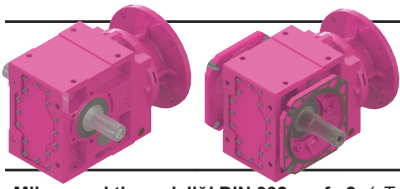

# Ölçü Sayfaları

## Dimension Pages

### Abmessungsseiten

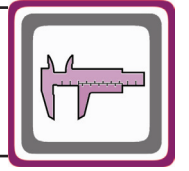

-Mil ucu çektirme deliği DIN 332 sayfa 2 / Tapped center hole to DIN 332, sheet 2 / Zentrierung mit Gewinde DIN 332, Blatt 2

#### KN573.04

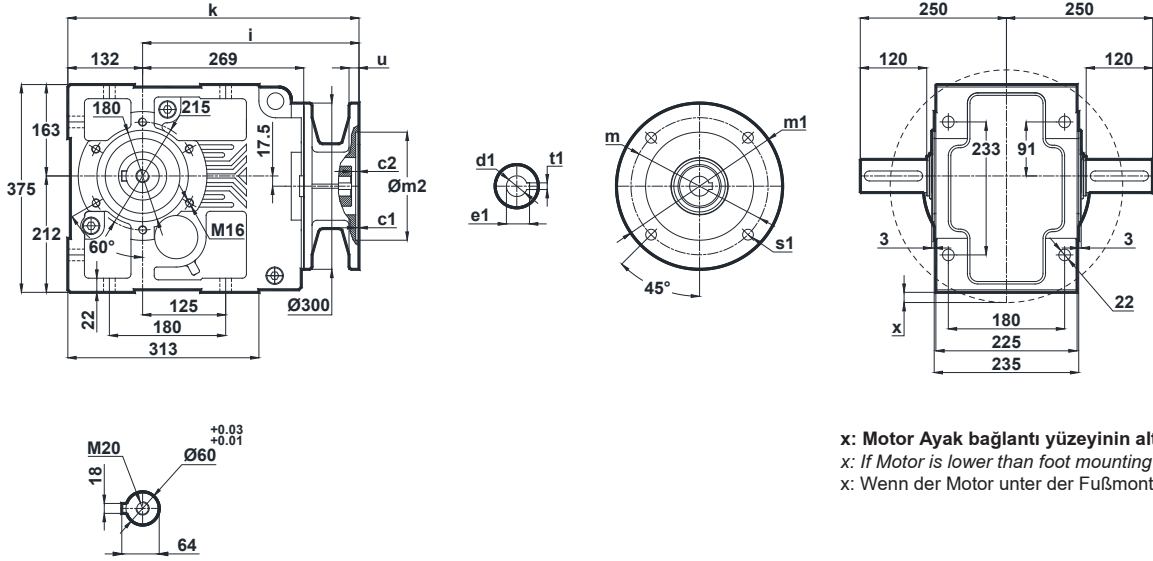

x: Motor Ayak bağlantı yüzeyinin altında ise  
x: If Motor is lower than foot mounting plane  
x: Wenn der Motor unter der Fußmontageebene ist

	c1	c2	s1	m	m1	m2	i	u	k	d1	t1	e1	x
100/B5	4.5	20	15	215	250	180	342	15	474	28	8	31.3	-
112/B5	4.5	20	15	215	250	180	342	15	474	28	8	31.3	-
132/B5 132/B14	4.5	9	15 11	265 165	300 200	230 130	363	15	495	38	10	41.3	-
160/B5	5.5	10	19	300	350	250	438	18	570	42	12	45.3	-
180/B5	5.5	10	19	300	350	250	438	18	570	48	14	51.8	-

#### KN573.05

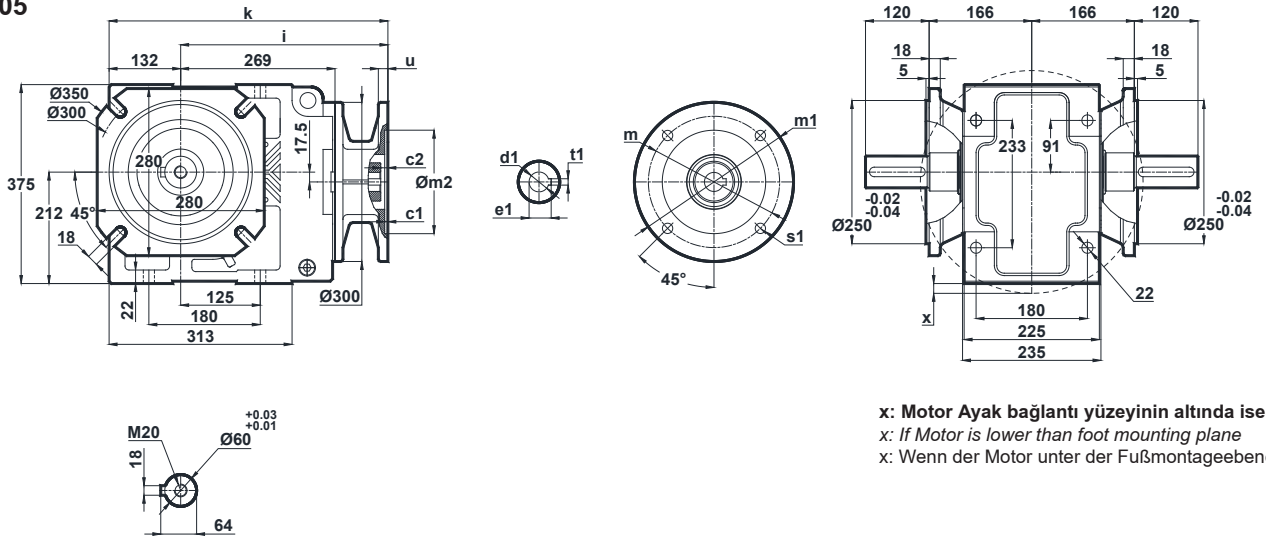

x: Motor Ayak bağlantı yüzeyinin altında ise  
x: If Motor is lower than foot mounting plane  
x: Wenn der Motor unter der Fußmontageebene ist

	c1	c2	s1	m	m1	m2	i	u	k	d1	t1	e1	x
100/B5	4.5	20	15	215	250	180	342	15	474	28	8	31.3	-
112/B5	4.5	20	15	215	250	180	342	15	474	28	8	31.3	-
132/B5 132/B14	4.5	9	15 11	265 165	300 200	230 130	363	15	495	38	10	41.3	-
160/B5	5.5	10	19	300	350	250	438	18	570	42	12	45.3	-
180/B5	5.5	10	19	300	350	250	438	18	570	48	14	51.8	-



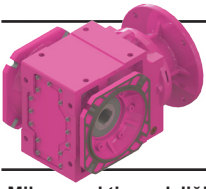

# Ölçü Sayfaları Dimension Pages Abmessungsseiten

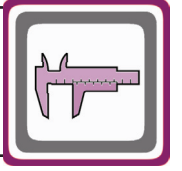

-Mil ucu çekirme deliği DIN 332 sayfa 2 / Tapped center hole to DIN 332, sheet 2 / Zentrierung mit Gewinde DIN 332, Blatt 2

KN573.08

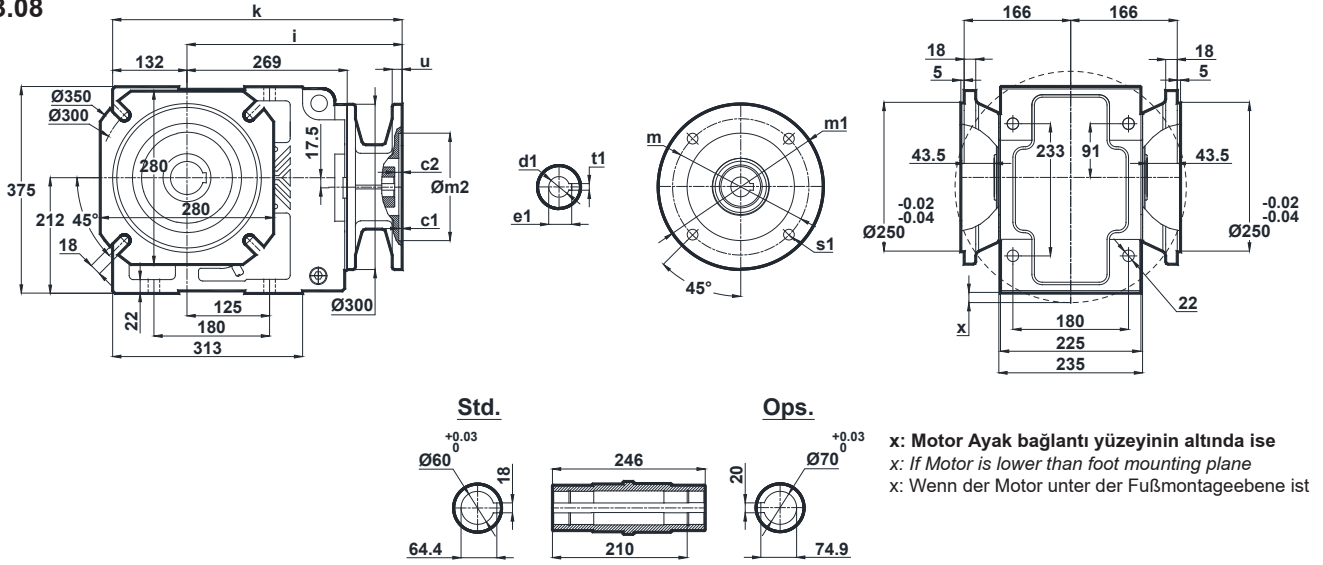

	c1	c2	s1	m	m1	m2	i	u	k	d1	t1	e1	x
100/B5	4.5	20	15	215	250	180	342	15	474	28	8	31.3	-
112/B5	4.5	20	15	215	250	180	342	15	474	28	8	31.3	-
132/B5 132/B14	4.5	9	15 11	265 165	300 200	230 130	363	15	495	38	10	41.3	-
160/B5	5.5	10	19	300	350	250	438	18	570	42	12	45.3	-
180/B5	5.5	10	19	300	350	250	438	18	570	48	14	51.8	-

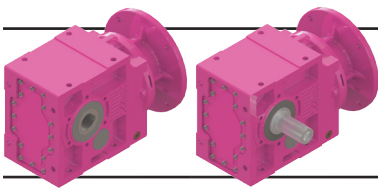

# Ölçü Sayfaları

## Dimension Pages

### Abmessungsseiten

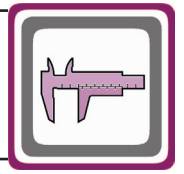

-Mil ucu çekirme deliği DIN 332 sayfa 2 / Tapped center hole to DIN 332, sheet 2 / Zentrierung mit Gewinde DIN 332, Blatt 2

#### KN574.00

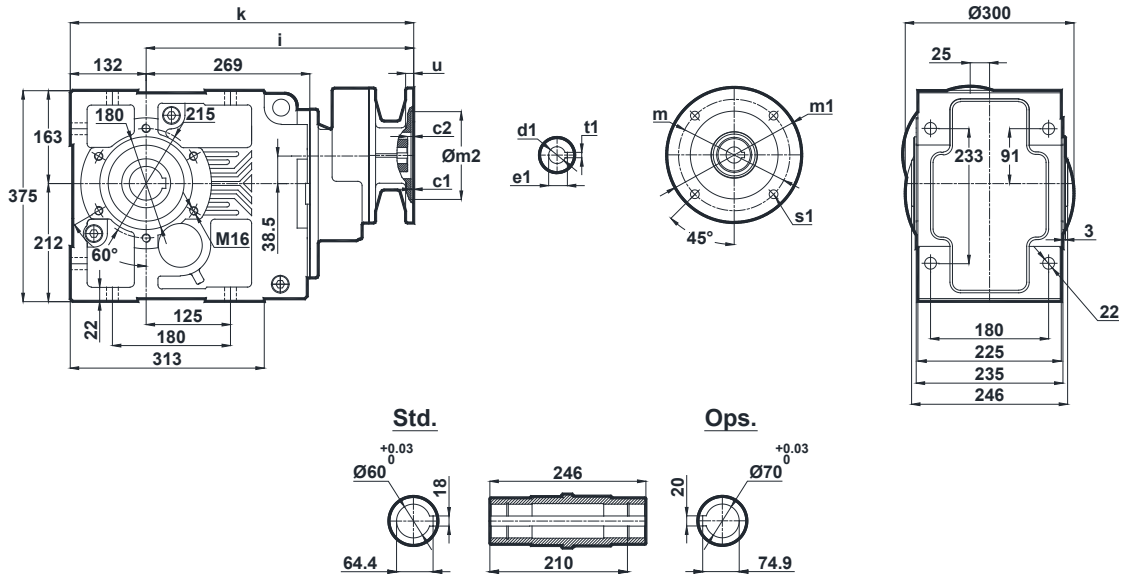

	c1	c2	s1	m	m1	m2	i	u	k	d1	t1	e1
71/B5	4	9	11	130	160	110	422	12	554	14	5	16.3
80/B5	4	9	12	165	200	130	422	12	554	19	6	21.8
80/B14			7	100	120	80						
90/B5	4	9	12	165	200	130	422	12	554	24	8	27.3
90/B14			9	115	140	95						26.3
100/B5	4.5	9	15	215	250	180	439	15	571	28	8	31.3

#### KN574.01

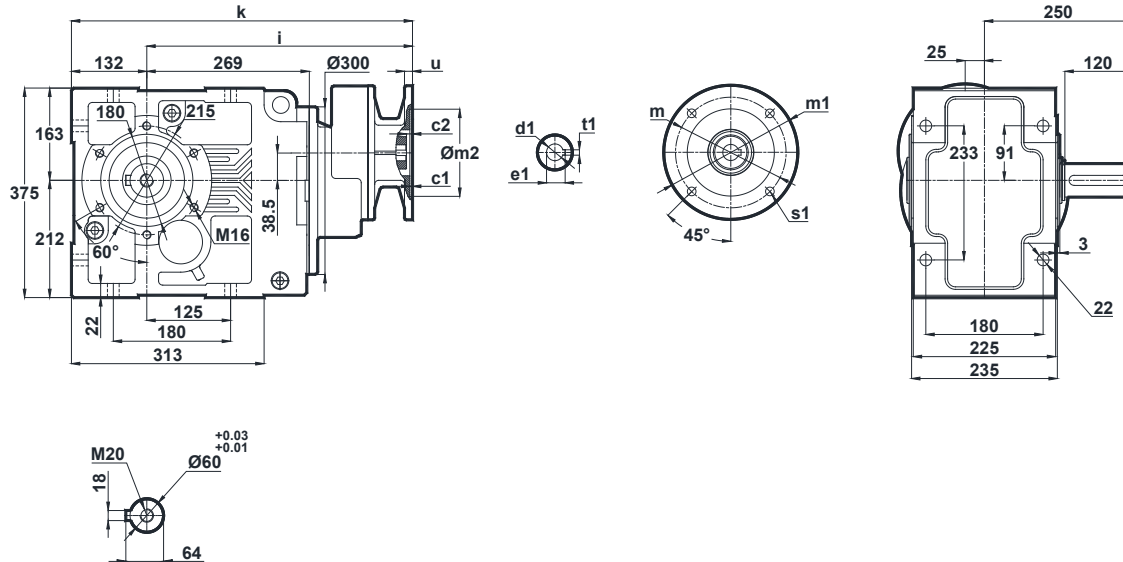

	c1	c2	s1	m	m1	m2	i	u	k	d1	t1	e1
71/B5	4	9	11	130	160	110	422	12	554	14	5	16.3
80/B5	4	9	12	165	200	130	422	12	554	19	6	21.8
80/B14			7	100	120	80						
90/B5	4	9	12	165	200	130	422	12	554	24	8	27.3
90/B14			9	115	140	95						26.3
100/B5	4.5	9	15	215	250	180	439	15	571	28	8	31.3

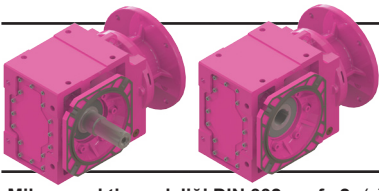

# Ölçü Sayfaları

## Dimension Pages

### Abmessungsseiten

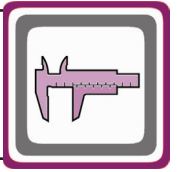

-Mil ucu çekirme deliği DIN 332 sayfa 2 / Tapped center hole to DIN 332, sheet 2 / Zentrierung mit Gewinde DIN 332, Blatt 2

#### KN574.02

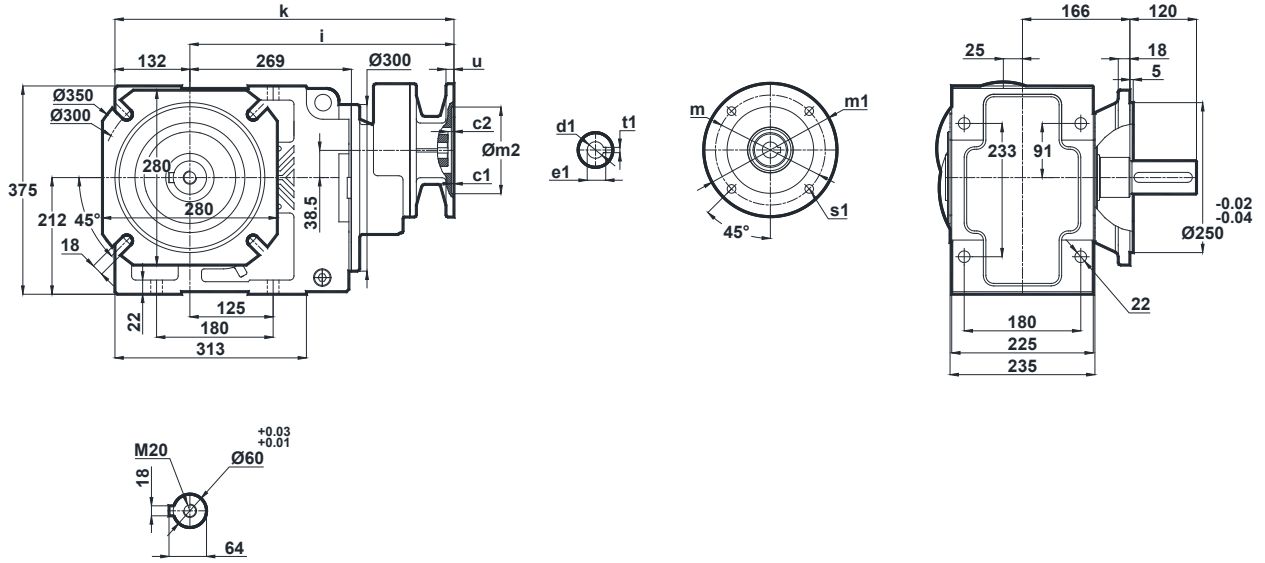

	c1	c2	s1	m	m1	m2	i	u	k	d1	t1	e1
71/B5	4	9	11	130	160	110	422	12	554	14	5	16.3
80/B5	4	9	12	165	200	130	422	12	554	19	6	21.8
80/B14	4	9	7	100	120	80	422	12	554	19	6	21.8
90/B5	4	9	12	165	200	130	422	12	554	24	8	27.3
90/B14	4	9	9	115	140	95	422	12	554	24	8	26.3
100/B5	4.5	9	15	215	250	180	439	15	571	28	8	31.3

#### KN574.03

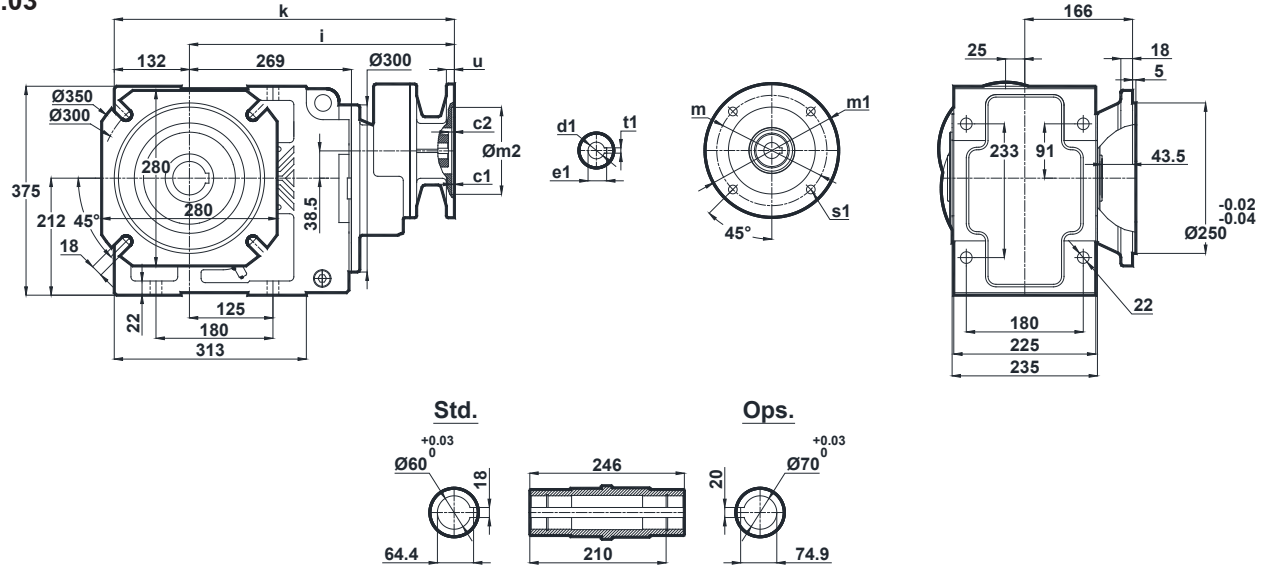

	c1	c2	s1	m	m1	m2	i	u	k	d1	t1	e1
71/B5	4	9	11	130	160	110	422	12	554	14	5	16.3
80/B5	4	9	12	165	200	130	422	12	554	19	6	21.8
80/B14	4	9	7	100	120	80	422	12	554	19	6	21.8
90/B5	4	9	12	165	200	130	422	12	554	24	8	27.3
90/B14	4	9	9	115	140	95	422	12	554	24	8	26.3
100/B5	4.5	9	15	215	250	180	439	15	571	28	8	31.3

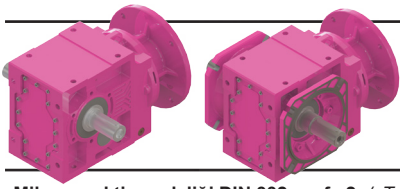

# Ölçü Sayfaları

## Dimension Pages

## Abmessungsseiten

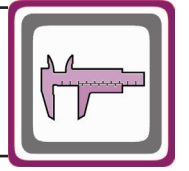

-Mil ucu çektirme deliği DIN 332 sayfa 2 / Tapped center hole to DIN 332, sheet 2 / Zentrierung mit Gewinde DIN 332, Blatt 2

### KN574.04

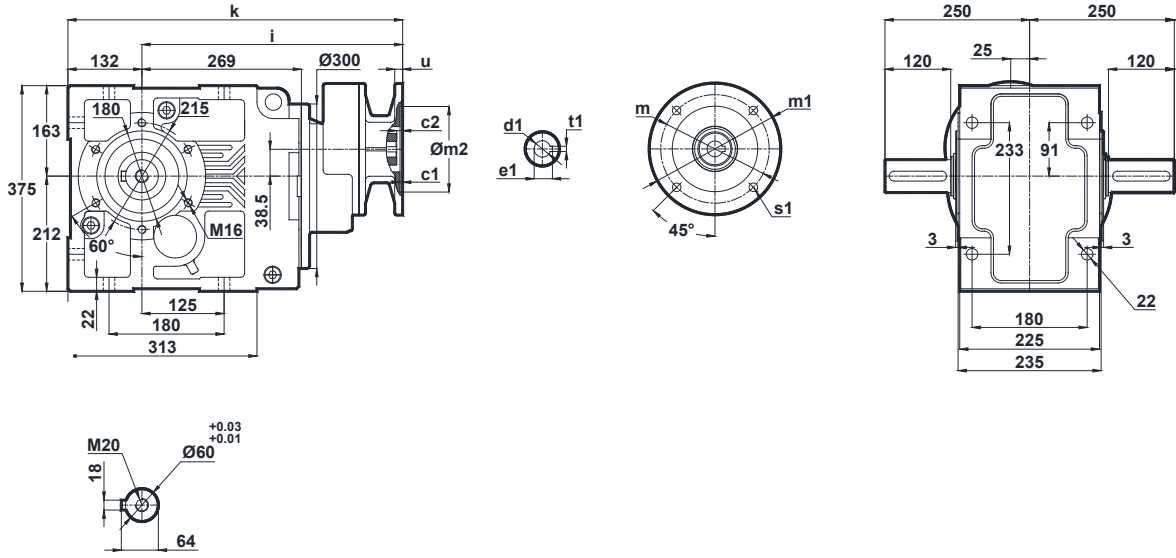

	c1	c2	s1	m	m1	m2	i	u	k	d1	t1	e1
71/B5	4	9	11	130	160	110	422	12	554	14	5	16.3
80/B5	4	9	12	165	200	130	422	12	554	19	6	21.8
80/B14	4	9	7	100	120	80	422	12	554	19	6	21.8
90/B5	4	9	12	165	200	130	422	12	554	24	8	27.3
90/B14	4	9	9	115	140	95	422	12	554	24	8	26.3
100/B5	4.5	9	15	215	250	180	439	15	571	28	8	31.3

### KN574.05

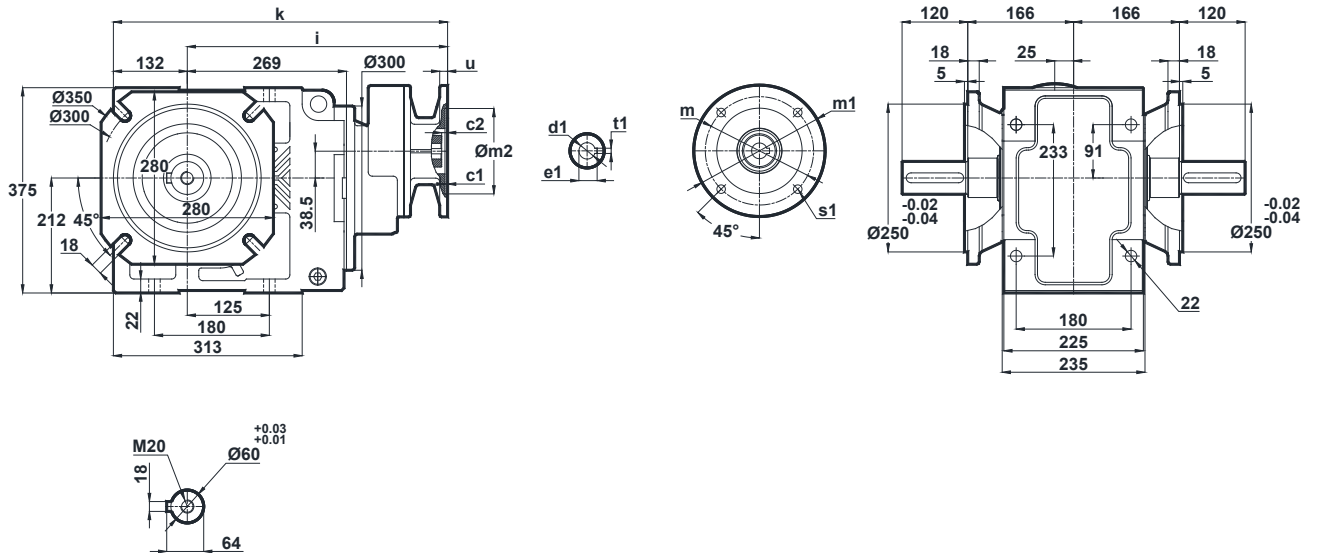

	c1	c2	s1	m	m1	m2	i	u	k	d1	t1	e1
71/B5	4	9	11	130	160	110	422	12	554	14	5	16.3
80/B5	4	9	12	165	200	130	422	12	554	19	6	21.8
80/B14	4	9	7	100	120	80	422	12	554	19	6	21.8
90/B5	4	9	12	165	200	130	422	12	554	24	8	27.3
90/B14	4	9	9	115	140	95	422	12	554	24	8	26.3
100/B5	4.5	9	15	215	250	180	439	15	571	28	8	31.3

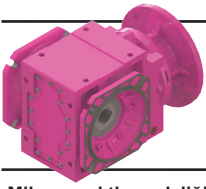

# Ölçü Sayfaları Dimension Pages Abmessungsseiten

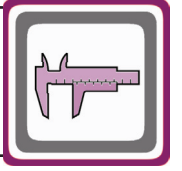

-Mil ucu çekirme deliği DIN 332 sayfa 2 / Tapped center hole to DIN 332, sheet 2 / Zentrierung mit Gewinde DIN 332, Blatt 2

KN574.08

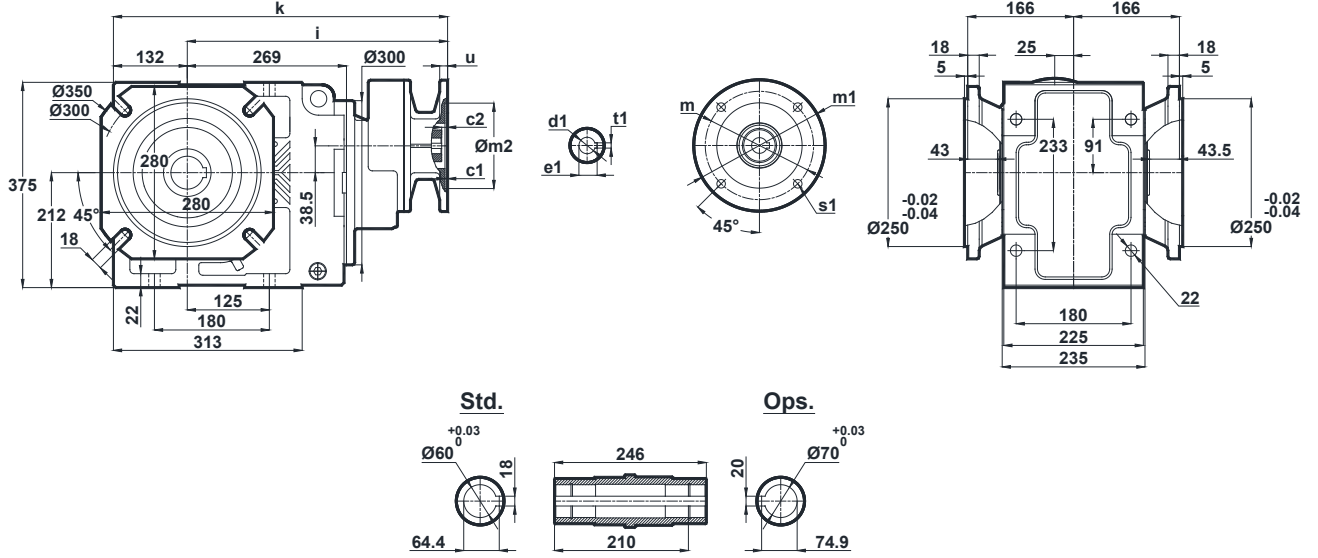

	c1	c2	s1	m	m1	m2	i	u	k	d1	t1	e1
71/B5	4	9	11	130	160	110	422	12	554	14	5	16.3
80/B5 80/B14	4	9	12 7	165 100	200 120	130 80	422	12	554	19	6	21.8
90/B5 90/B14	4	9	12 9	165 115	200 140	130 95	422	12	554	24	8	27.3 26.3
100/B5	4.5	9	15	215	250	180	439	15	571	28	8	31.3

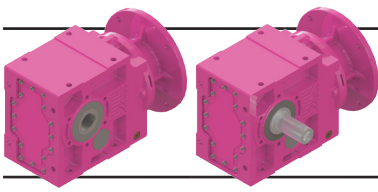

# Ölçü Sayfaları

## Dimension Pages

### Abmessungsseiten

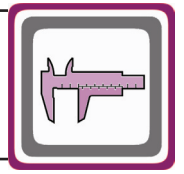

-Mil ucu çekirme deliği DIN 332 sayfa 2 / Tapped center hole to DIN 332, sheet 2 / Zentrierung mit Gewinde DIN 332, Blatt 2

KN575.00  
KN576.00

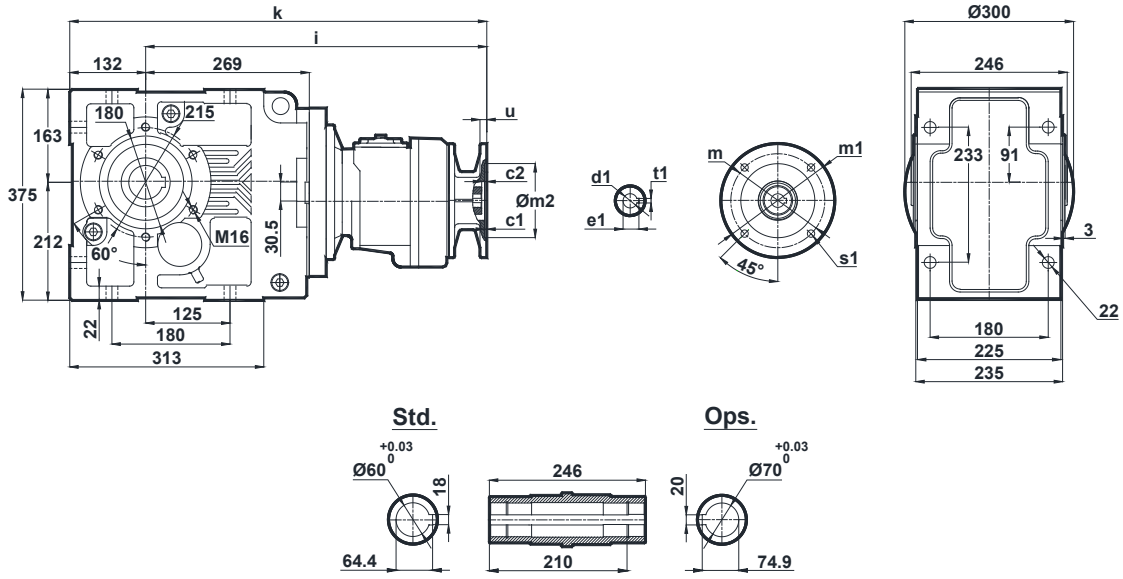

	c1	c2	s1	m	m1	m2	i	u	k	d1	t1	e1
63/B5	3.5	8	9	115	140	95	552	12	684	11	4	12.8
71/B5	4	8.5	11	130	160	110	523	12	655	14	5	16.3
71/B14	3		7	85	105	70		10				
80/B5	4	5	12	165	200	130	552	12	684	19	6	21.8
80/B14			7	100	120	80						

KN575.01  
KN576.01

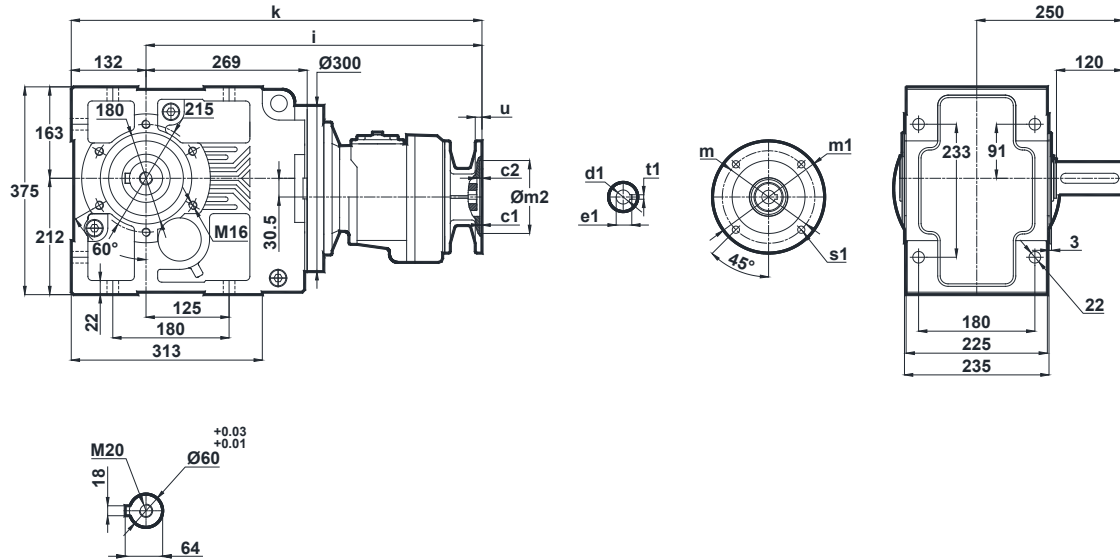

	c1	c2	s1	m	m1	m2	i	u	k	d1	t1	e1
63/B5	3.5	8	9	115	140	95	552	12	684	11	4	12.8
71/B5	4	8.5	11	130	160	110	523	12	655	14	5	16.3
71/B14	3		7	85	105	70		10				
80/B5	4	5	12	165	200	130	552	12	684	19	6	21.8
80/B14			7	100	120	80						

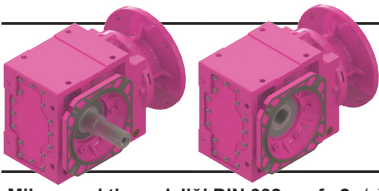

# Ölçü Sayfaları

## Dimension Pages

### Abmessungsseiten

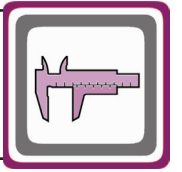

-Mil ucu çekirme deliği DIN 332 sayfa 2 / Tapped center hole to DIN 332, sheet 2 / Zentrierung mit Gewinde DIN 332, Blatt 2

KN575.02  
KN576.02

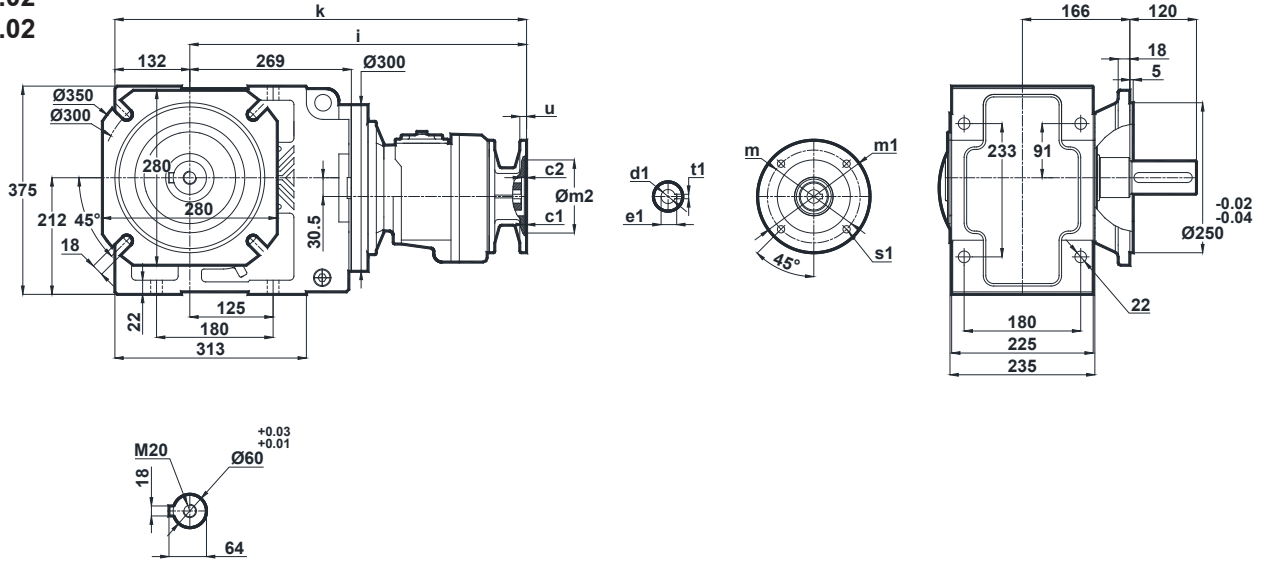

	c1	c2	s1	m	m1	m2	i	u	k	d1	t1	e1
63/B5	3.5	8	9	115	140	95	552	12	684	11	4	12.8
71/B5	4	8.5	11	130	160	110	523	12	655	14	5	16.3
71/B14	3		7	85	105	70		10				
80/B5	4	5	12	165	200	130	552	12	684	19	6	21.8
80/B14			7	100	80	80						

KN575.03  
KN576.03

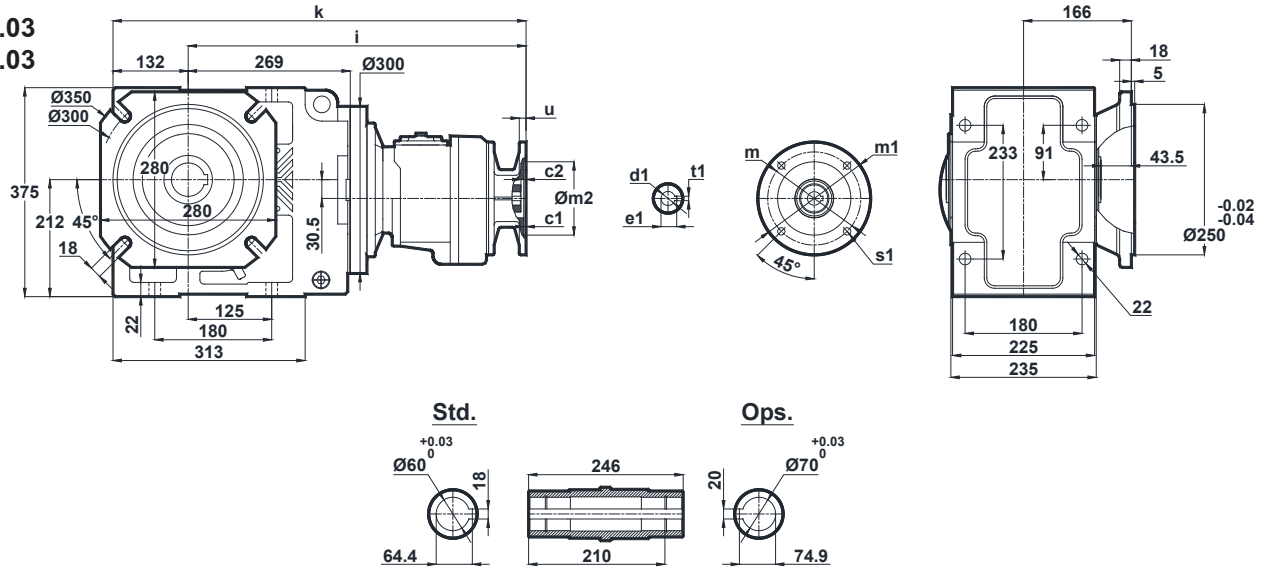

	c1	c2	s1	m	m1	m2	i	u	k	d1	t1	e1
63/B5	3.5	8	9	115	140	95	552	12	684	11	4	12.8
71/B5	4	8.5	11	130	160	110	523	12	655	14	5	16.3
71/B14	3		7	85	105	70		10				
80/B5	4	5	12	165	200	130	552	12	684	19	6	21.8
80/B14			7	100	80	80						

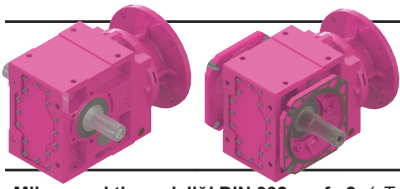

# Ölçü Sayfaları

## Dimension Pages

## Abmessungsseiten

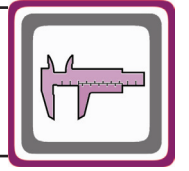

-Mil ucu çektirme deliği DIN 332 sayfa 2 / Tapped center hole to DIN 332, sheet 2 / Zentrierung mit Gewinde DIN 332, Blatt 2

KN575.04  
KN576.04

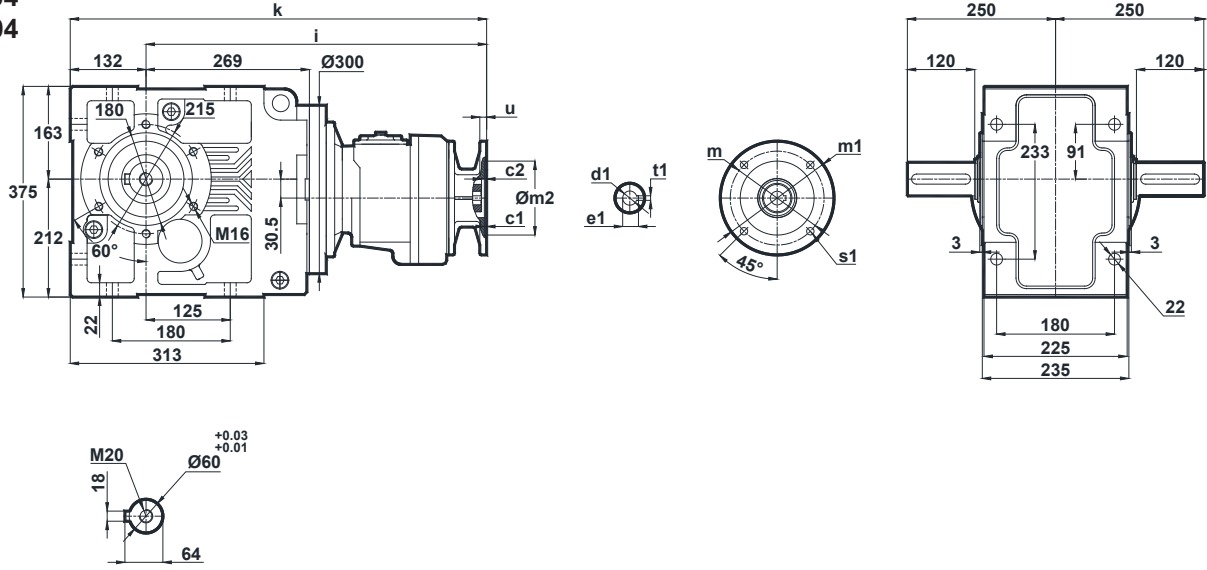

	c1	c2	s1	m	m1	m2	i	u	k	d1	t1	e1
63/B5	3.5	8	9	115	140	95	552	12	684	11	4	12.8
71/B5	4	8.5	11	130	160	110	523	12	655	14	5	16.3
71/B14	3		7	85	105	70		10				
80/B5	4	5	12	165	200	130	552	12	684	19	6	21.8
80/B14			7	100	120	80						

KN575.05  
KN576.05

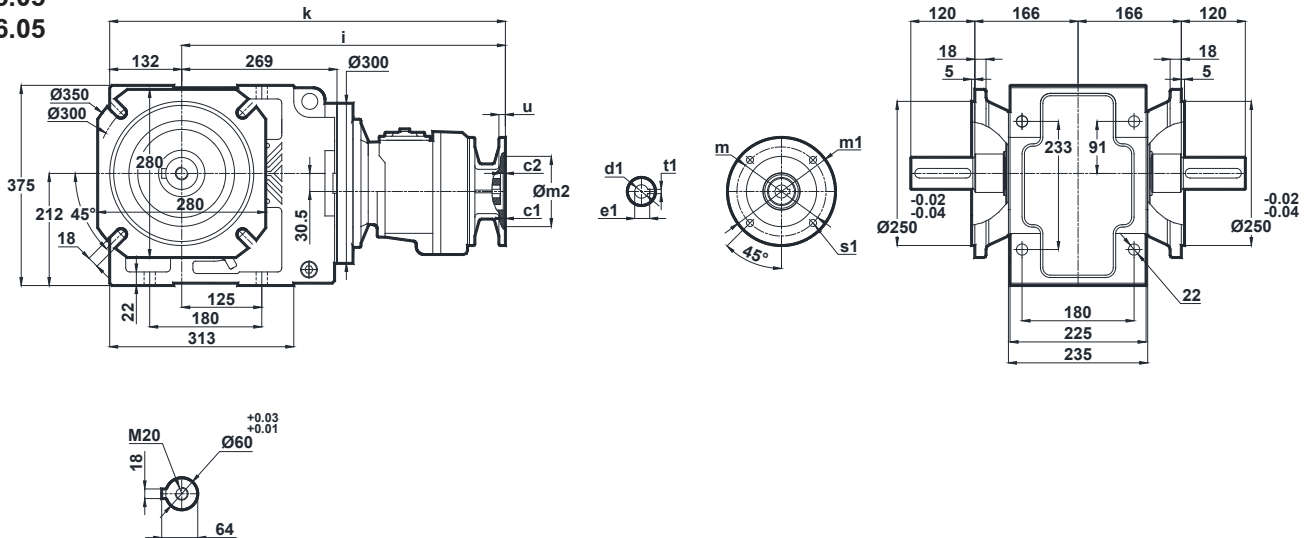

	c1	c2	s1	m	m1	m2	i	u	k	d1	t1	e1
63/B5	3.5	8	9	115	140	95	552	12	684	11	4	12.8
71/B5	4	8.5	11	130	160	110	523	12	655	14	5	16.3
71/B14	3		7	85	105	70		10				
80/B5	4	5	12	165	200	130	552	12	684	19	6	21.8
80/B14			7	100	120	80						



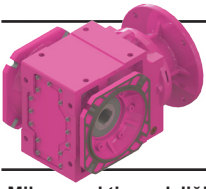

# Ölçü Sayfaları

## Dimension Pages

### Abmessungsseiten

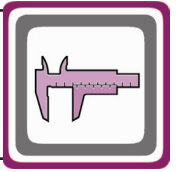

-Mil ucu çekirme deliği DIN 332 sayfa 2 / Tapped center hole to DIN 332, sheet 2 / Zentrierung mit Gewinde DIN 332, Blatt 2

KN575.08  
KN576.08

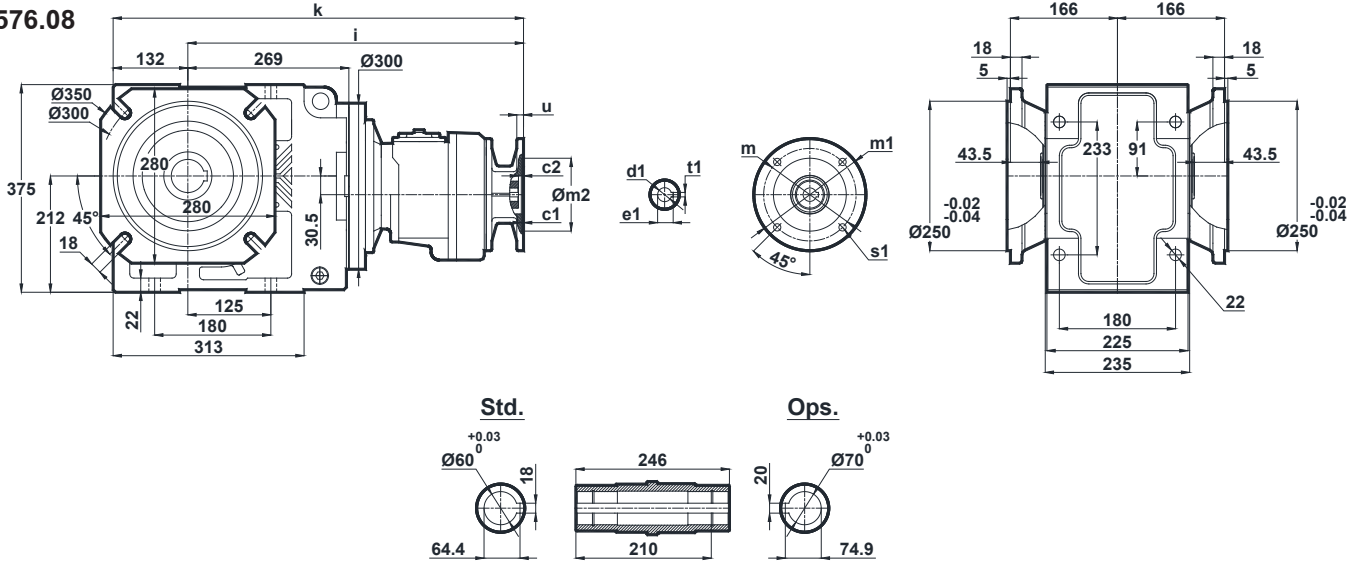

	c1	c2	s1	m	m1	m2	i	u	k	d1	t1	e1
63/B5	3.5	8	9	115	140	95	552	12	684	11	4	12.8
71/B5	4	8.5	11	130	160	110	523	12	655	14	5	16.3
71/B14	3		7	85	105	70		10				
80/B5	4	5	12	165	200	130	552	12	684	19	6	21.8
80/B14			7	100	120	80						

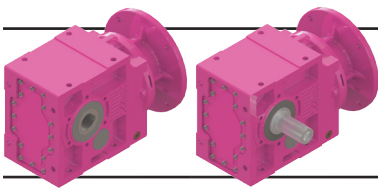

# Ölçü Sayfaları

## Dimension Pages

### Abmessungsseiten

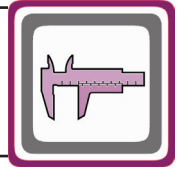

-Mil ucu çekirme deliği DIN 332 sayfa 2 / Tapped center hole to DIN 332, sheet 2 / Zentrierung mit Gewinde DIN 332, Blatt 2

#### KN673.00

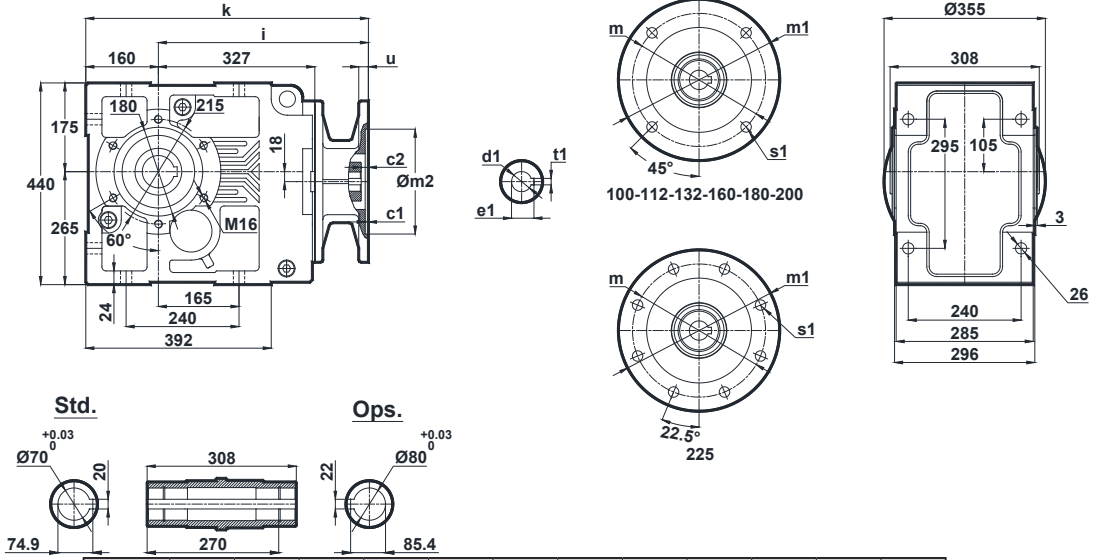

	c1	c2	s1	m	m1	m2	i	u	k	d1	t1	e1
100/B5	4.5	14.5	15	215	250	180	396	15	556	28	8	31.3
112/B5	4.5	14.5	15	215	250	180	396	15	556	28	8	31.3
132/B5 132/B14	4.5	9	15	265 165	300 200	230 130	411	15	571	38	10	41.3
160/B5	5.5	10	19	300	350	250	486	20	646	42	12	45.3
180/B5	5.5	10	19	300	350	250	486	20	646	48	14	51.8
200/B5	5.5	10	19	350	400	300	506	22	743	55	16	59.3
225/B5	5.5	10	19	400	450	350	559	24	796	60	18	64.4

#### KN673.01

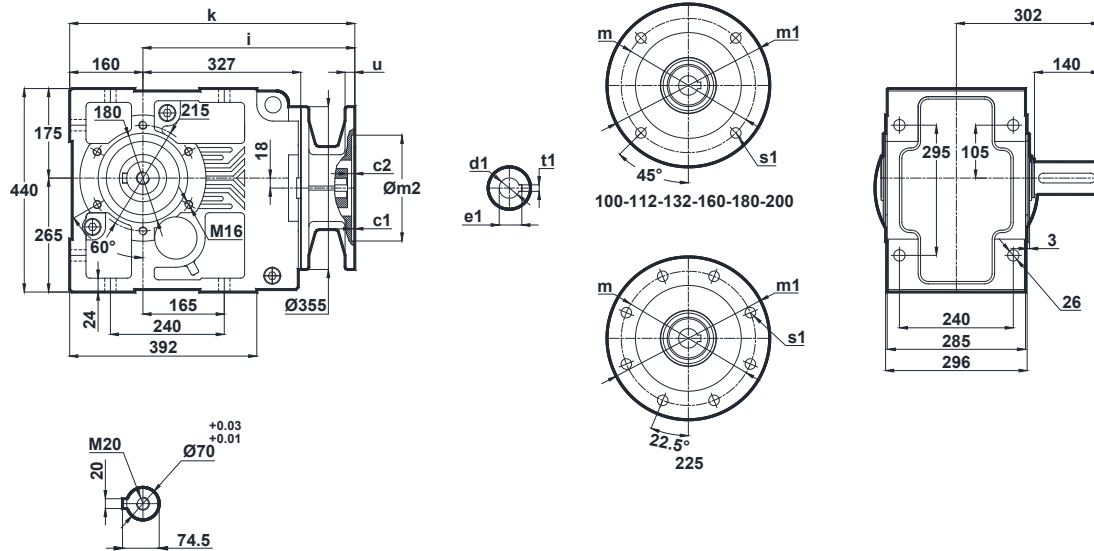

	c1	c2	s1	m	m1	m2	i	u	k	d1	t1	e1
100/B5	4.5	14.5	15	215	250	180	396	15	556	28	8	31.3
112/B5	4.5	14.5	15	215	250	180	396	15	556	28	8	31.3
132/B5 132/B14	4.5	9	15	265 165	300 200	230 130	411	15	571	38	10	41.3
160/B5	5.5	10	19	300	350	250	486	20	646	42	12	45.3
180/B5	5.5	10	19	300	350	250	486	20	646	48	14	51.8
200/B5	5.5	10	19	350	400	300	506	22	743	55	16	59.3
225/B5	5.5	10	19	400	450	350	559	24	796	60	18	64.4

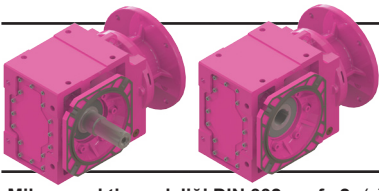

# Ölçü Sayfaları

## Dimension Pages

### Abmessungsseiten

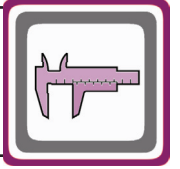

-Mil ucu çekirme deliği DIN 332 sayfa 2 / Tapped center hole to DIN 332, sheet 2 / Zentrierung mit Gewinde DIN 332, Blatt 2

#### KN673.02

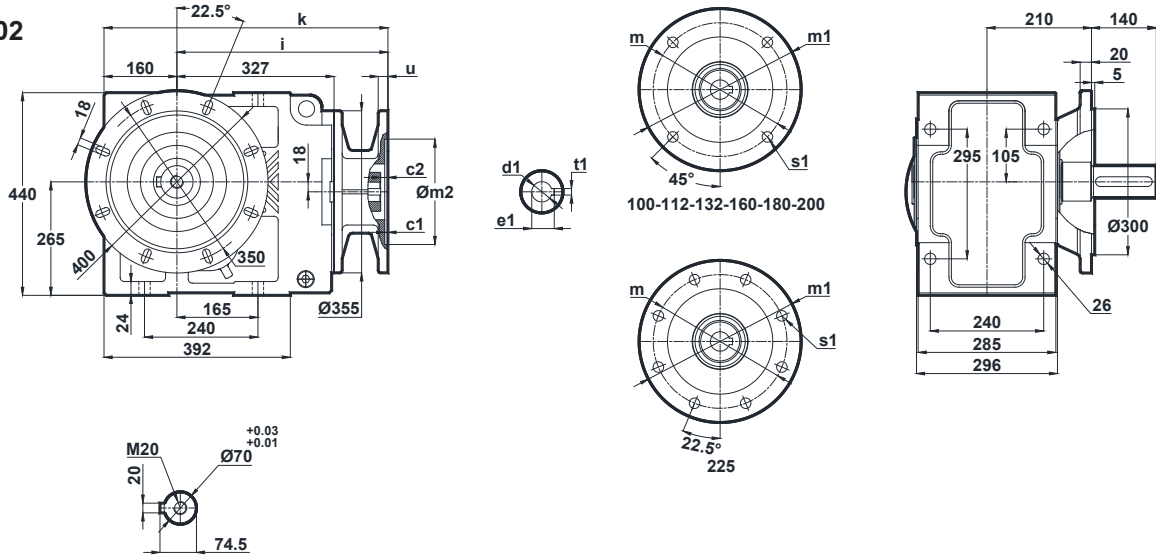

	c1	c2	s1	m	m1	m2	i	u	k	d1	t1	e1
100/B5	4.5	14.5	15	215	250	180	396	15	556	28	8	31.3
112/B5	4.5	14.5	15	215	250	180	396	15	556	28	8	31.3
132/B5 132/B14	4.5	9	15	265 165	300 200	230 130	411	15	571	38	10	41.3
160/B5	5.5	10	19	300	350	250	486	20	646	42	12	45.3
180/B5	5.5	10	19	300	350	250	486	20	646	48	14	51.8
200/B5	5.5	10	19	350	400	300	506	22	743	55	16	59.3
225/B5	5.5	10	19	400	450	350	559	24	796	60	18	64.4

#### KN673.03

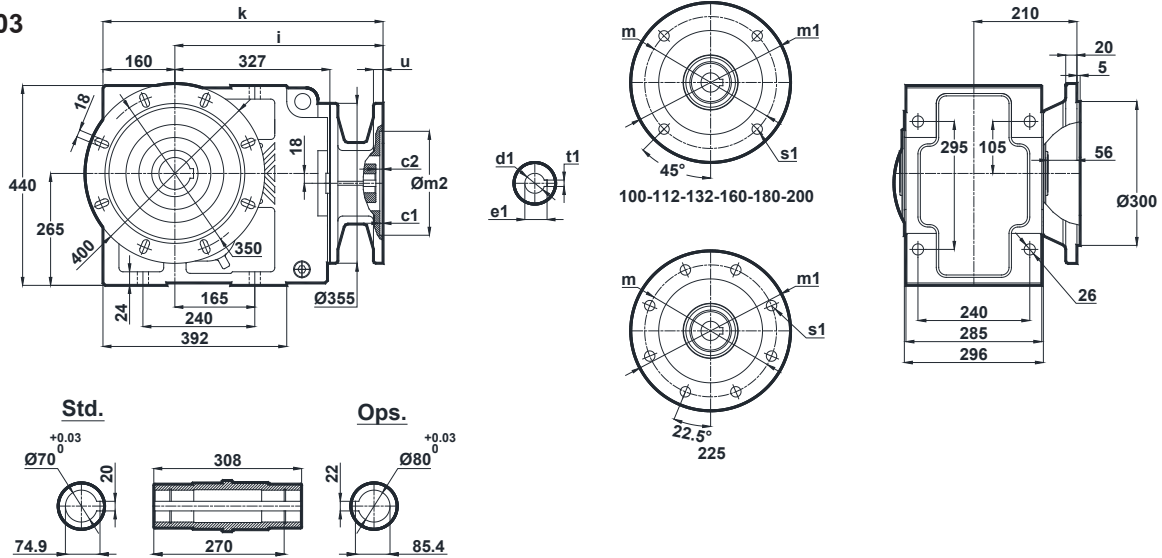

	c1	c2	s1	m	m1	m2	i	u	k	d1	t1	e1
100/B5	4.5	14.5	15	215	250	180	396	15	556	28	8	31.3
112/B5	4.5	14.5	15	215	250	180	396	15	556	28	8	31.3
132/B5 132/B14	4.5	9	15	265 165	300 200	230 130	411	15	571	38	10	41.3
160/B5	5.5	10	19	300	350	250	486	20	646	42	12	45.3
180/B5	5.5	10	19	300	350	250	486	20	646	48	14	51.8
200/B5	5.5	10	19	350	400	300	506	22	743	55	16	59.3
225/B5	5.5	10	19	400	450	350	559	24	796	60	18	64.4

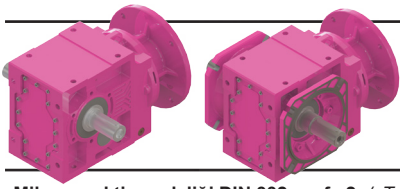

# Ölçü Sayfaları

## Dimension Pages

### Abmessungsseiten

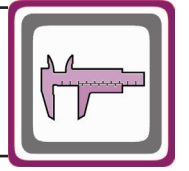

-Mil ucu çekirme deliği DIN 332 sayfa 2 / Tapped center hole to DIN 332, sheet 2 / Zentrierung mit Gewinde DIN 332, Blatt 2

#### KN673.04

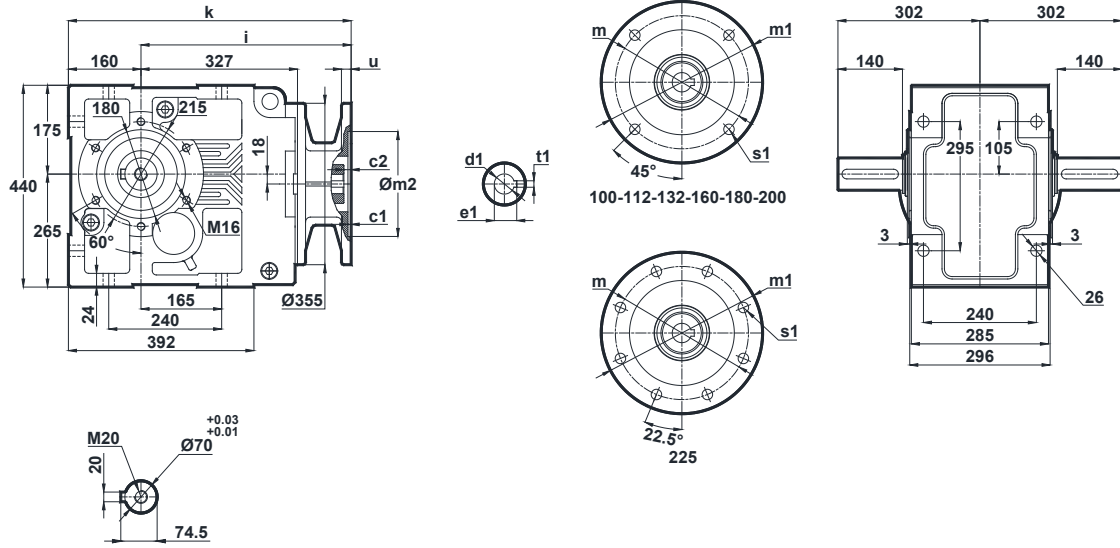

	c1	c2	s1	m	m1	m2	i	u	k	d1	t1	e1
100/B5	4.5	14.5	15	215	250	180	396	15	556	28	8	31.3
112/B5	4.5	14.5	15	215	250	180	396	15	556	28	8	31.3
132/B5 132/B14	4.5	9	15	265 165	300 200	230 130	411	15	571	38	10	41.3
160/B5	5.5	10	19	300	350	250	486	20	646	42	12	45.3
180/B5	5.5	10	19	300	350	250	486	20	646	48	14	51.8
200/B5	5.5	10	19	350	400	300	506	22	743	55	16	59.3
225/B5	5.5	10	19	400	450	350	559	24	796	60	18	64.4

#### KN673.05

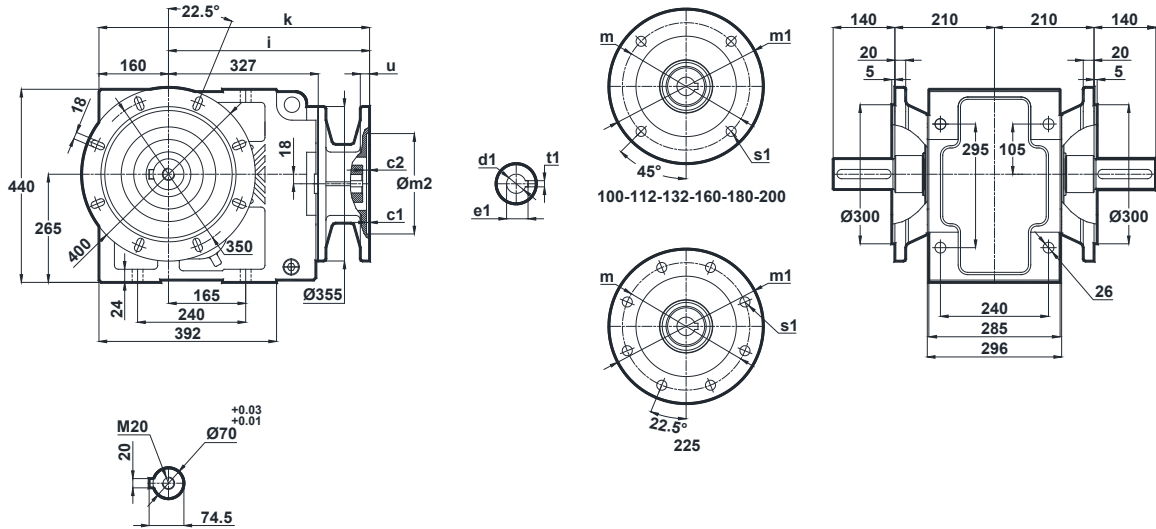

	c1	c2	s1	m	m1	m2	i	u	k	d1	t1	e1
100/B5	4.5	14.5	15	215	250	180	396	15	556	28	8	31.3
112/B5	4.5	14.5	15	215	250	180	396	15	556	28	8	31.3
132/B5 132/B14	4.5	9	15	265 165	300 200	230 130	411	15	571	38	10	41.3
160/B5	5.5	10	19	300	350	250	486	20	646	42	12	45.3
180/B5	5.5	10	19	300	350	250	486	20	646	48	14	51.8
200/B5	5.5	10	19	350	400	300	506	22	743	55	16	59.3
225/B5	5.5	10	19	400	450	350	559	24	796	60	18	64.4

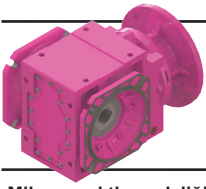

# Ölçü Sayfaları Dimension Pages Abmessungenseiten

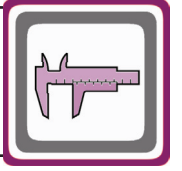

-Mil ucu çektirme deliği DIN 332 sayfa 2 / Tapped center hole to DIN 332, sheet 2 / Zentrierung mit Gewinde DIN 332, Blatt 2

KN673.08

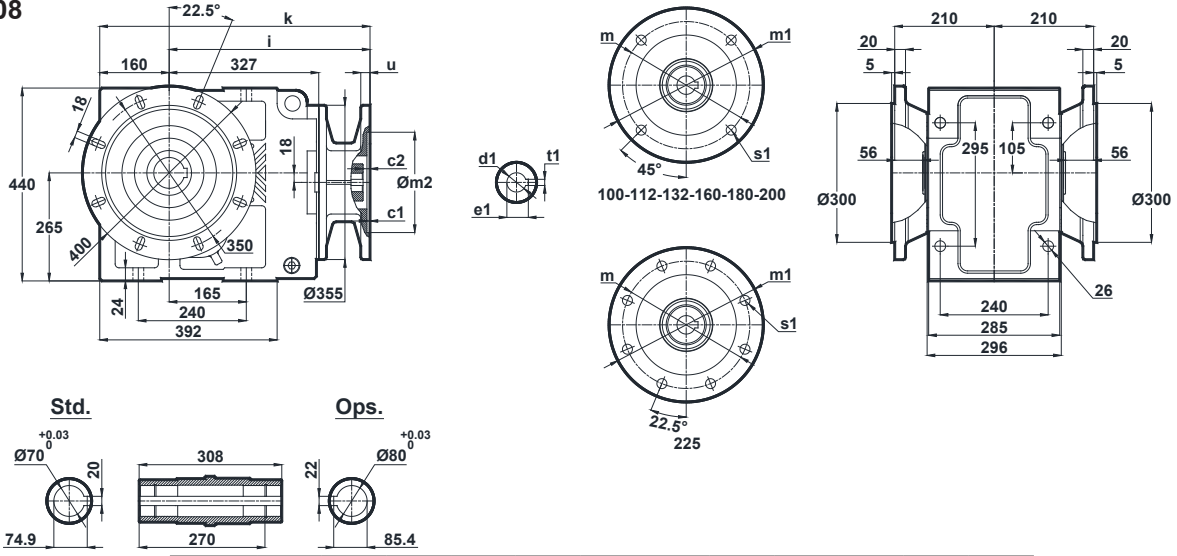

	c1	c2	s1	m	m1	m2	i	u	k	d1	t1	e1
100/B5	4.5	14.5	15	215	250	180	396	15	556	28	8	31.3
112/B5	4.5	14.5	15	215	250	180	396	15	556	28	8	31.3
132/B5 132/B14	4.5	9	15	265 165	300 200	230 130	411	15	571	38	10	41.3
160/B5	5.5	10	19	300	350	250	486	20	646	42	12	45.3
180/B5	5.5	10	19	300	350	250	486	20	646	48	14	51.8
200/B5	5.5	10	19	350	400	300	506	22	743	55	16	59.3
225/B5	5.5	10	19	400	450	350	559	24	796	60	18	64.4

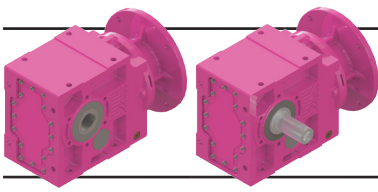

# Ölçü Sayfaları

## Dimension Pages

### Abmessungsseiten

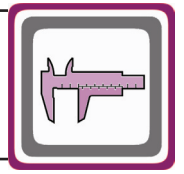

-Mil ucu çekirme deliği DIN 332 sayfa 2 / Tapped center hole to DIN 332, sheet 2 / Zentrierung mit Gewinde DIN 332, Blatt 2

#### KN674.00

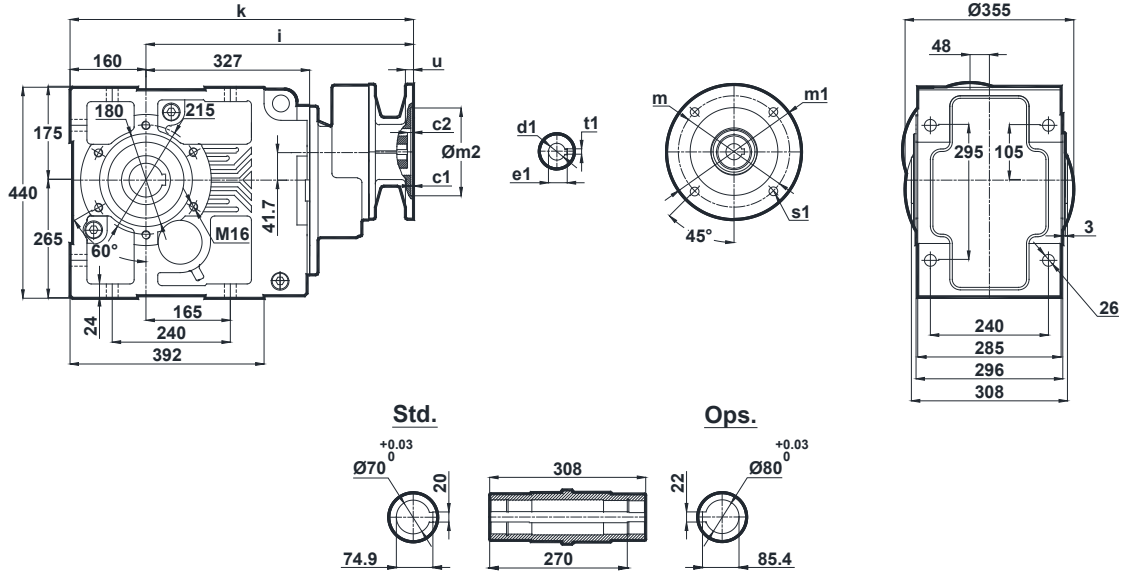

	c1	c2	s1	m	m1	m2	i	u	k	d1	t1	e1
80/B5	4	5	12	162	200	130	486	12	646	19	6	21.8
90/B5	4	5	13	165	200	130	486	12	646	24	8	27.3
90/B14			9	115	140	95						
100/B5	4.5	9	15	215	250	180	504	15	664	28	8	31.3
100/B14	3.5		9	130	160	110						

#### KN674.01

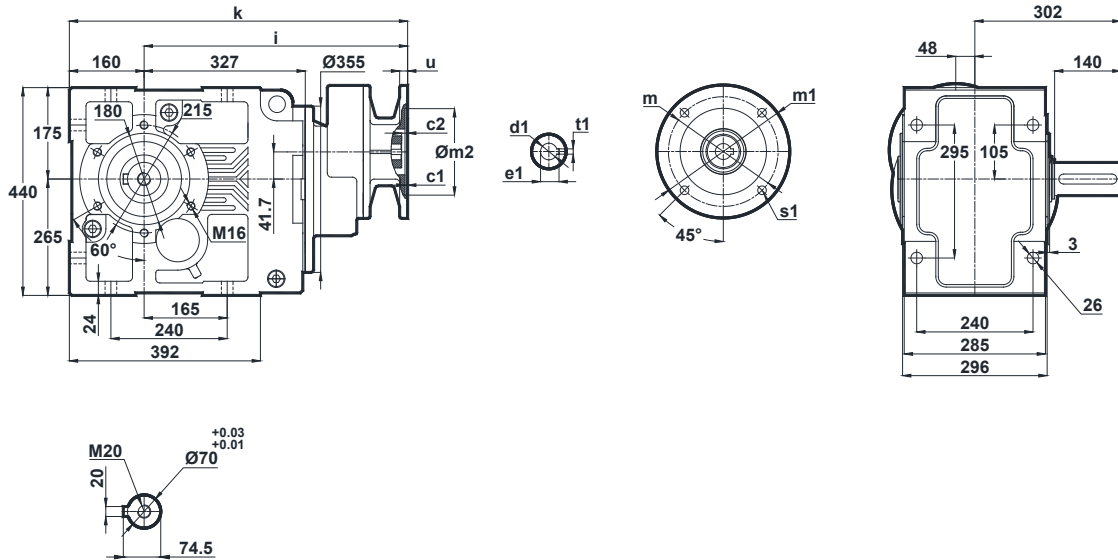

	c1	c2	s1	m	m1	m2	i	u	k	d1	t1	e1
80/B5	4	5	12	162	200	130	486	12	646	19	6	21.8
90/B5	4	5	13	165	200	130	486	12	646	24	8	27.3
90/B14			9	115	140	95						
100/B5	4.5	9	15	215	250	180	504	15	664	28	8	31.3
100/B14	3.5		9	130	160	110						

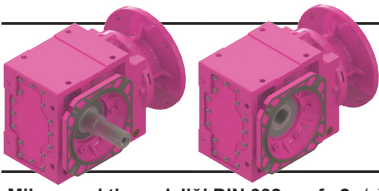

# Ölçü Sayfaları

## Dimension Pages

### Abmessungsseiten

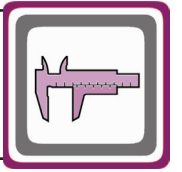

-Mil ucu çektirme deliği DIN 332 sayfa 2 / Tapped center hole to DIN 332, sheet 2 / Zentrierung mit Gewinde DIN 332, Blatt 2

#### KN674.02

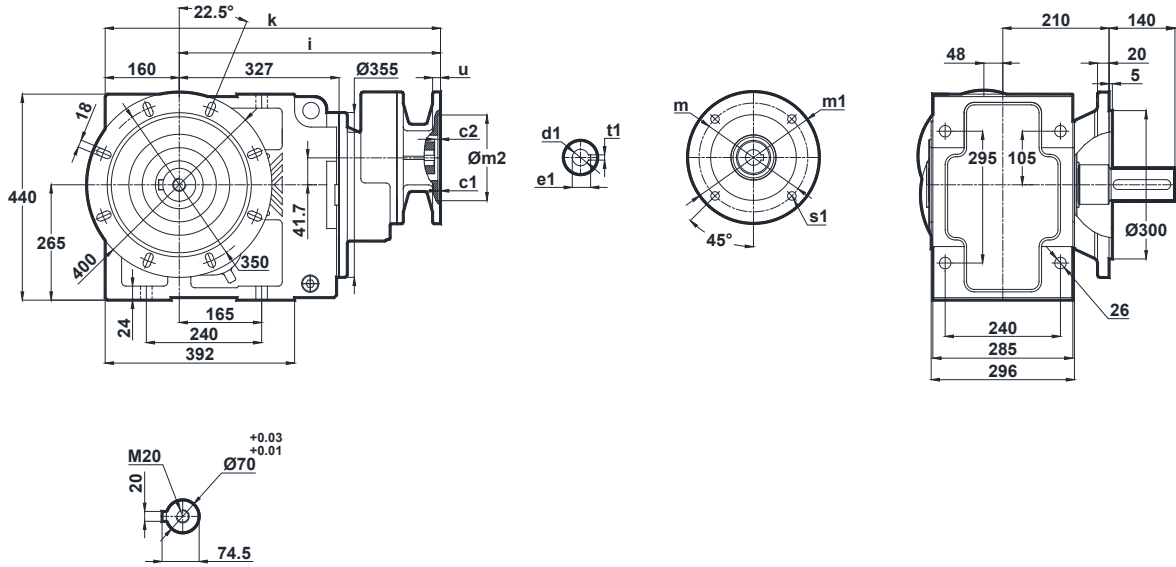

	c1	c2	s1	m	m1	m2	i	u	k	d1	t1	e1
80/B5	4	5	12	162	200	130	486	12	646	19	6	21.8
90/B5 90/B14	4	5	13 9	165 115	200 140	130 95	486	12	646	24	8	27.3
100/B5 100/B14	4.5 3.5	9	15 9	215 130	250 160	180 110	504	15	664	28	8	31.3

#### KN674.03

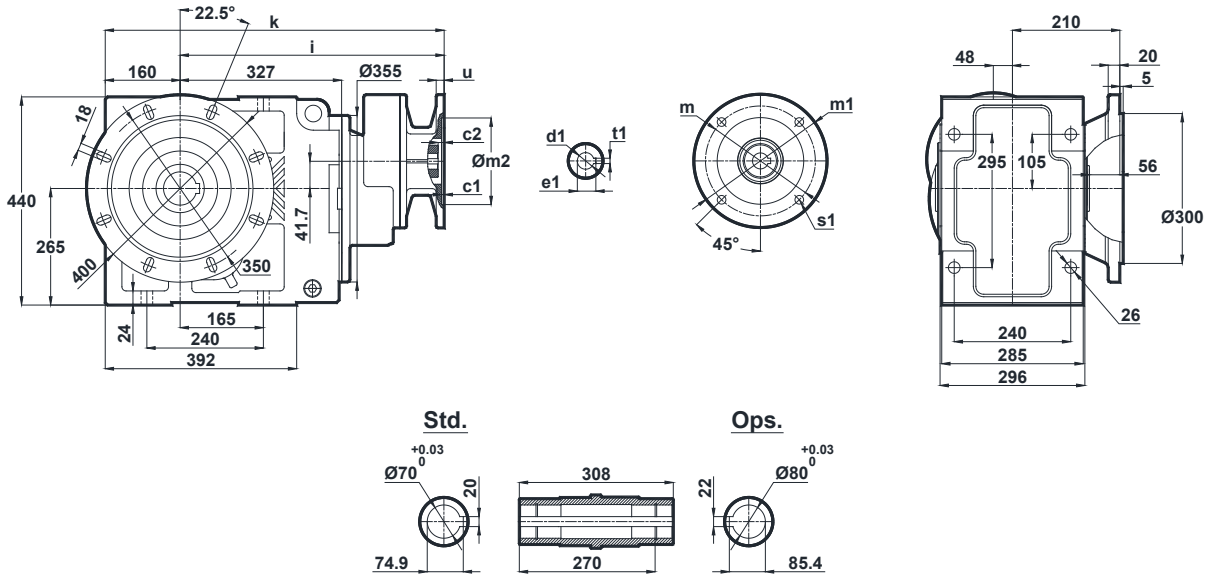

	c1	c2	s1	m	m1	m2	i	u	k	d1	t1	e1
80/B5	4	5	12	162	200	130	486	12	646	19	6	21.8
90/B5 90/B14	4	5	13 9	165 115	200 140	130 95	486	12	646	24	8	27.3
100/B5 100/B14	4.5 3.5	9	15 9	215 130	250 160	180 110	504	15	664	28	8	31.3

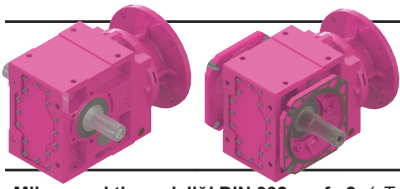

# Ölçü Sayfaları

## Dimension Pages

### Abmessungsseiten

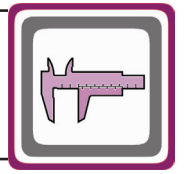

-Mil ucu çekirme deliği DIN 332 sayfa 2 / Tapped center hole to DIN 332, sheet 2 / Zentrierung mit Gewinde DIN 332, Blatt 2

#### KN674.04

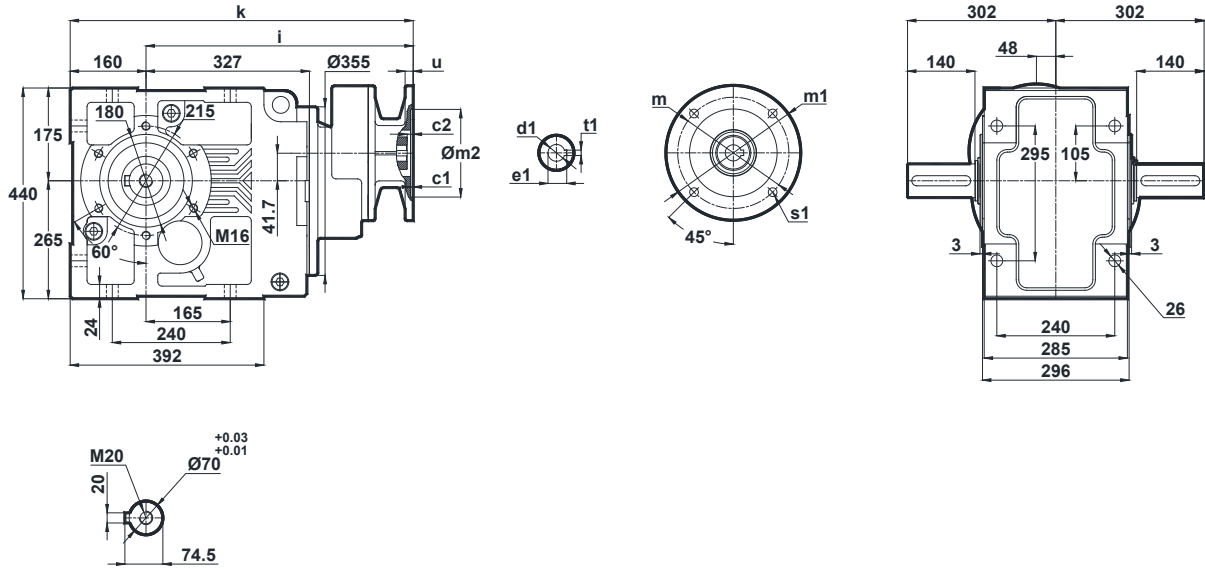

	c1	c2	s1	m	m1	m2	i	u	k	d1	t1	e1
80/B5	4	5	12	162	200	130	486	12	646	19	6	21.8
90/B5	4	5	13	165	200	130	486	12	646	24	8	27.3
90/B14			9	115	140	95						
100/B5	4.5	9	15	215	250	180	504	15	664	28	8	31.3
100/B14	3.5		9	130	160	110						

#### KN674.05

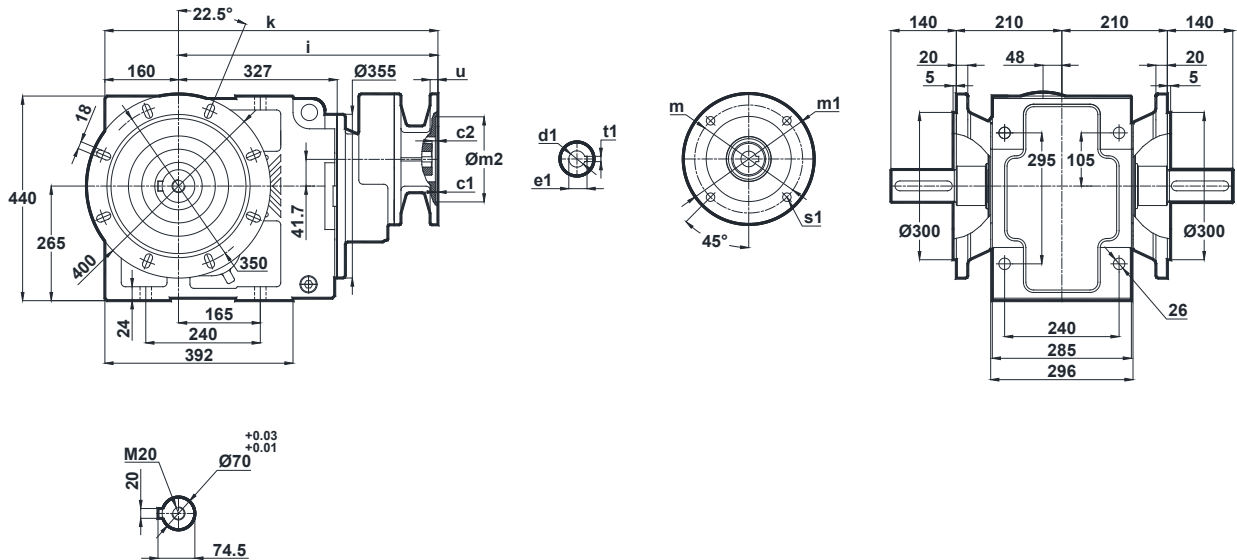

	c1	c2	s1	m	m1	m2	i	u	k	d1	t1	e1
80/B5	4	5	12	162	200	130	486	12	646	19	6	21.8
90/B5	4	5	13	165	200	130	486	12	646	24	8	27.3
90/B14			9	115	140	95						
100/B5	4.5	9	15	215	250	180	504	15	664	28	8	31.3
100/B14	3.5		9	130	160	110						



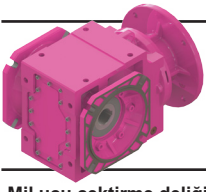

# Ölçü Sayfaları Dimension Pages Abmessungenseiten

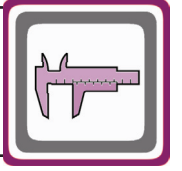

-Mil ucu çekirme deliği DIN 332 sayfa 2 / Tapped center hole to DIN 332, sheet 2 / Zentrierung mit Gewinde DIN 332, Blatt 2

## KN674.08

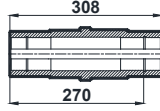
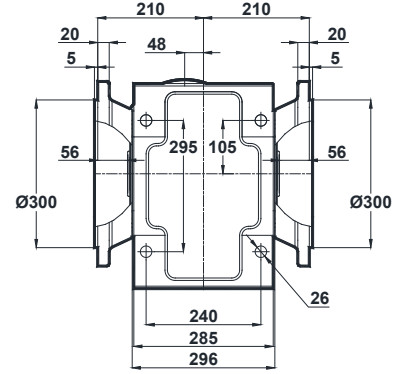
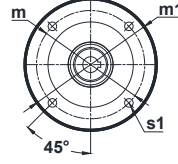
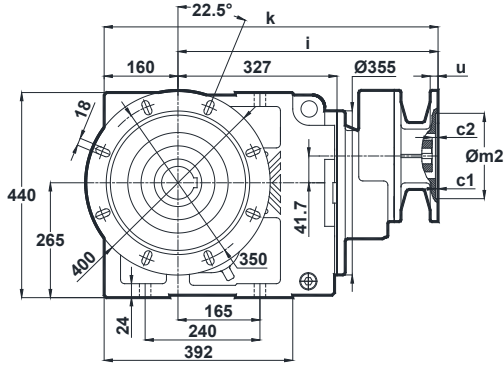

	c1	c2	s1	m	m1	m2	i	u	k	d1	t1	e1
80/B5	4	5	12	162	200	130	486	12	646	19	6	21.8
90/B5	4	5	13	165	200	130	486	12	646	24	8	27.3
90/B14			9	115	140	95						
100/B5	4.5	9	15	215	250	180	504	15	664	28	8	31.3
100/B14	3.5		9	130	160	110						

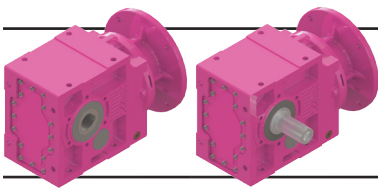

# Ölçü Sayfaları

## Dimension Pages

### Abmessungsseiten

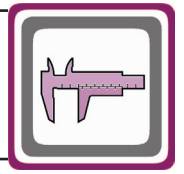

-Mil ucu çekirme deliği DIN 332 sayfa 2 / Tapped center hole to DIN 332, sheet 2 / Zentrierung mit Gewinde DIN 332, Blatt 2

KN675.00  
KN676.00

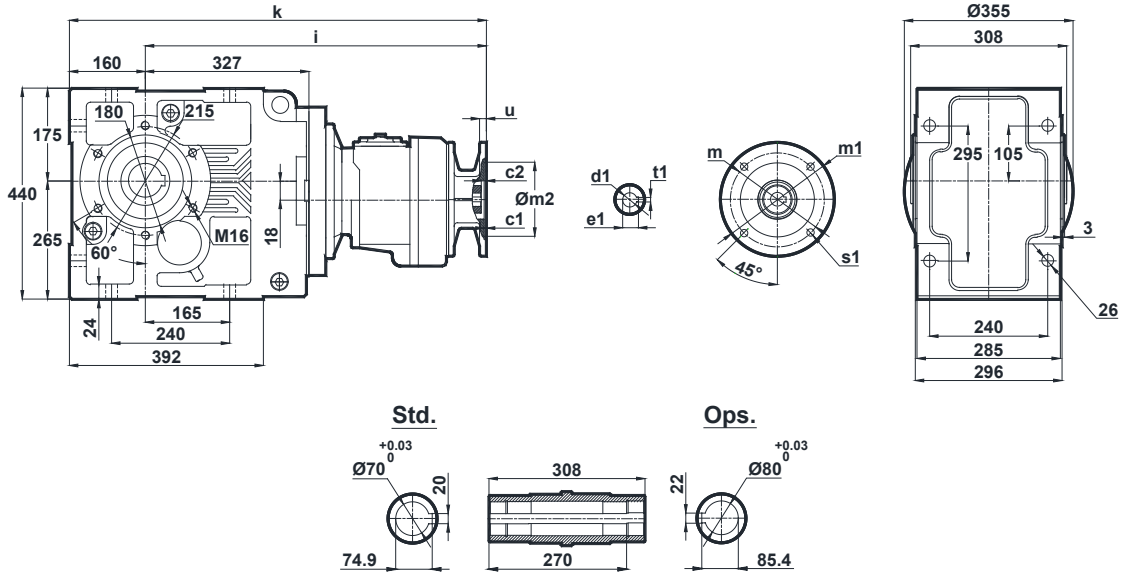

	c1	c2	s1	m	m1	m2	i	u	k	d1	t1	e1
71/B5	4	9	11	130	160	110	637	12	797	14	5	16.3
80/B5 80/B14	4	9	13 7	165 100	200 120	130 80	637	12	797	19	6	21.8
90/B5 90/B14	4	9	13 9	165 115	200 140	130 95	637	12	797	24	8	27.3 26.3

KN675.01  
KN676.01

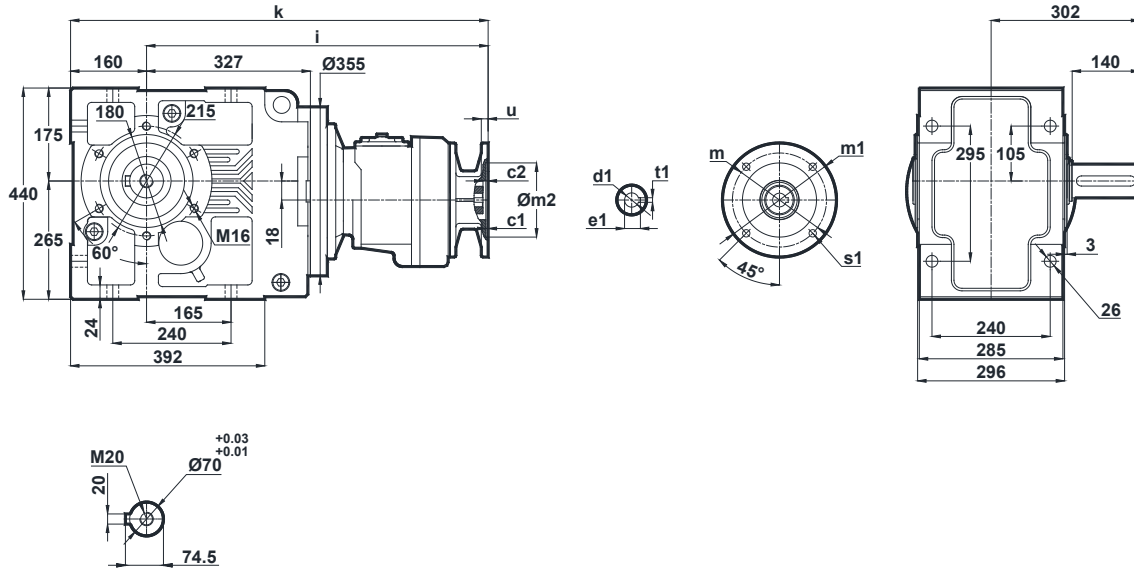

	c1	c2	s1	m	m1	m2	i	u	k	d1	t1	e1
71/B5	4	9	11	130	160	110	637	12	797	14	5	16.3
80/B5 80/B14	4	9	13 7	165 100	200 120	130 80	637	12	797	19	6	21.8
90/B5 90/B14	4	9	13 9	165 115	200 140	130 95	637	12	797	24	8	27.3 26.3

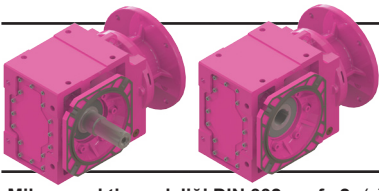

# Ölçü Sayfaları

## Dimension Pages

### Abmessungsseiten

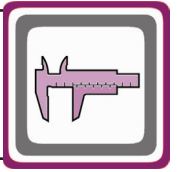

-Mil ucu çektirme deliği DIN 332 sayfa 2 / Tapped center hole to DIN 332, sheet 2 / Zentrierung mit Gewinde DIN 332, Blatt 2

KN675.02  
KN676.02

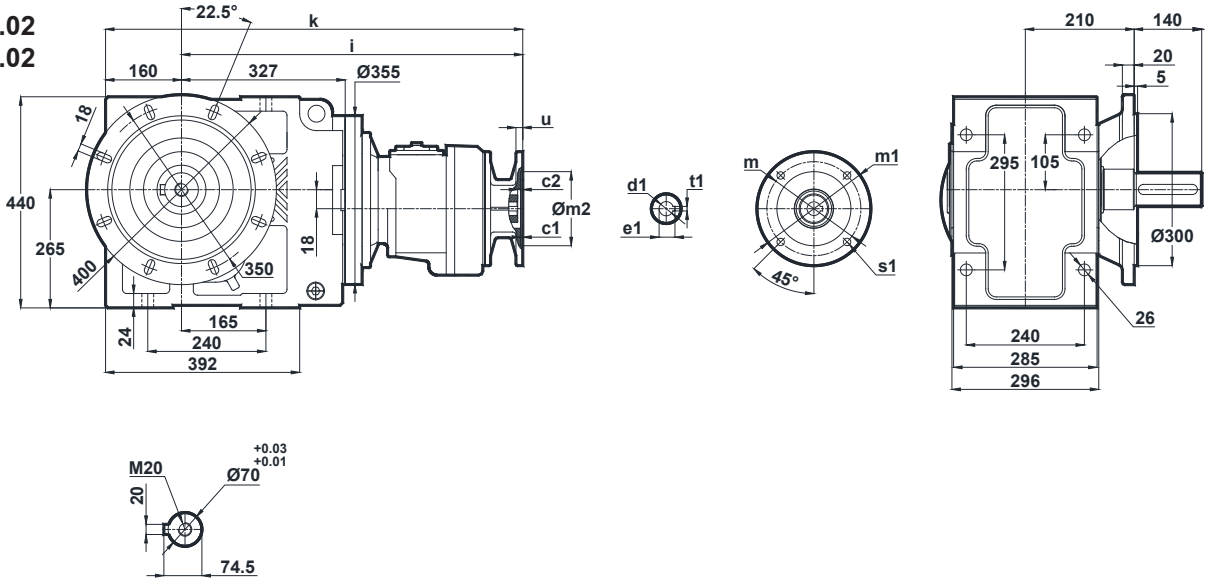

	c1	c2	s1	m	m1	m2	i	u	k	d1	t1	e1
71/B5	4	9	11	130	160	110	637	12	797	14	5	16.3
80/B5 80/B14	4	9	13 7	165 100	200 120	130 80	637	12	797	19	6	21.8
90/B5 90/B14	4	9	13 9	165 115	200 140	130 95	637	12	797	24	8	27.3 26.3

KN675.03  
KN676.03

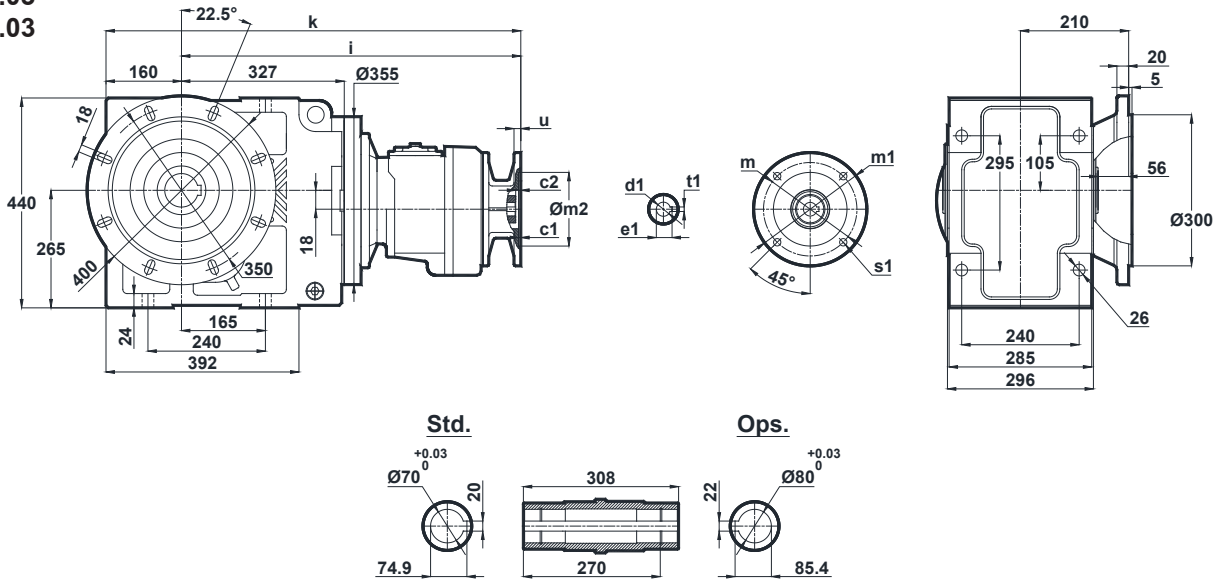

	c1	c2	s1	m	m1	m2	i	u	k	d1	t1	e1
71/B5	4	9	11	130	160	110	637	12	797	14	5	16.3
80/B5 80/B14	4	9	13 7	165 100	200 120	130 80	637	12	797	19	6	21.8
90/B5 90/B14	4	9	13 9	165 115	200 140	130 95	637	12	797	24	8	27.3 26.3

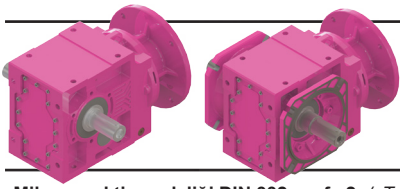

# Ölçü Sayfaları

## Dimension Pages

## Abmessungsseiten

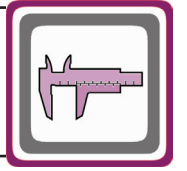

-Mil ucu çektirme deliği DIN 332 sayfa 2 / Tapped center hole to DIN 332, sheet 2 / Zentrierung mit Gewinde DIN 332, Blatt 2

KN675.04  
KN676.04

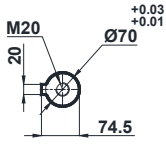
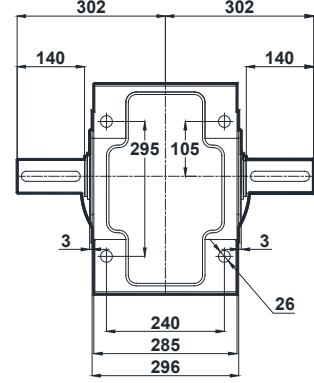
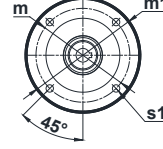
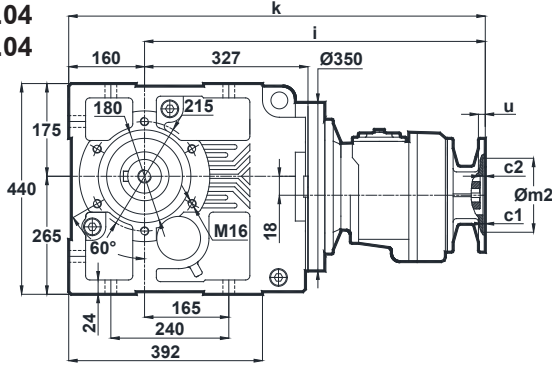

	c1	c2	s1	m	m1	m2	i	u	k	d1	t1	e1
71/B5	4	9	11	130	160	110	637	12	797	14	5	16.3
80/B5 80/B14	4	9	13 7	165 100	200 120	130 80	637	12	797	19	6	21.8
90/B5 90/B14	4	9	13 9	165 115	200 140	130 95	637	12	797	24	8	27.3 26.3

KN675.05  
KN676.05

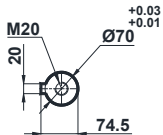
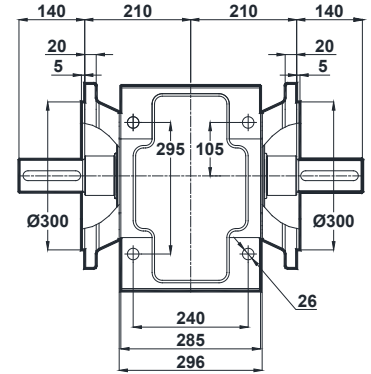
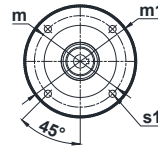
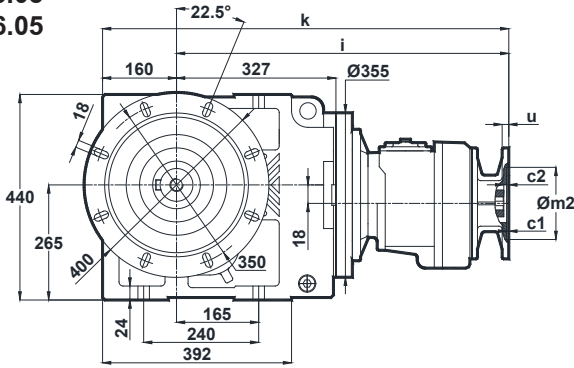

	c1	c2	s1	m	m1	m2	i	u	k	d1	t1	e1
71/B5	4	9	11	130	160	110	637	12	797	14	5	16.3
80/B5 80/B14	4	9	13 7	165 100	200 120	130 80	637	12	797	19	6	21.8
90/B5 90/B14	4	9	13 9	165 115	200 140	130 95	637	12	797	24	8	27.3 26.3

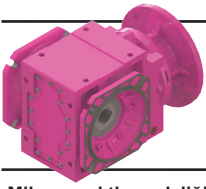

# Ölçü Sayfaları Dimension Pages Abmessungenseiten

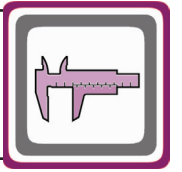

-Mil ucu çekirme deliği DIN 332 sayfa 2 / Tapped center hole to DIN 332, sheet 2 / Zentrierung mit Gewinde DIN 332, Blatt 2

KN675.08  
KN676.08

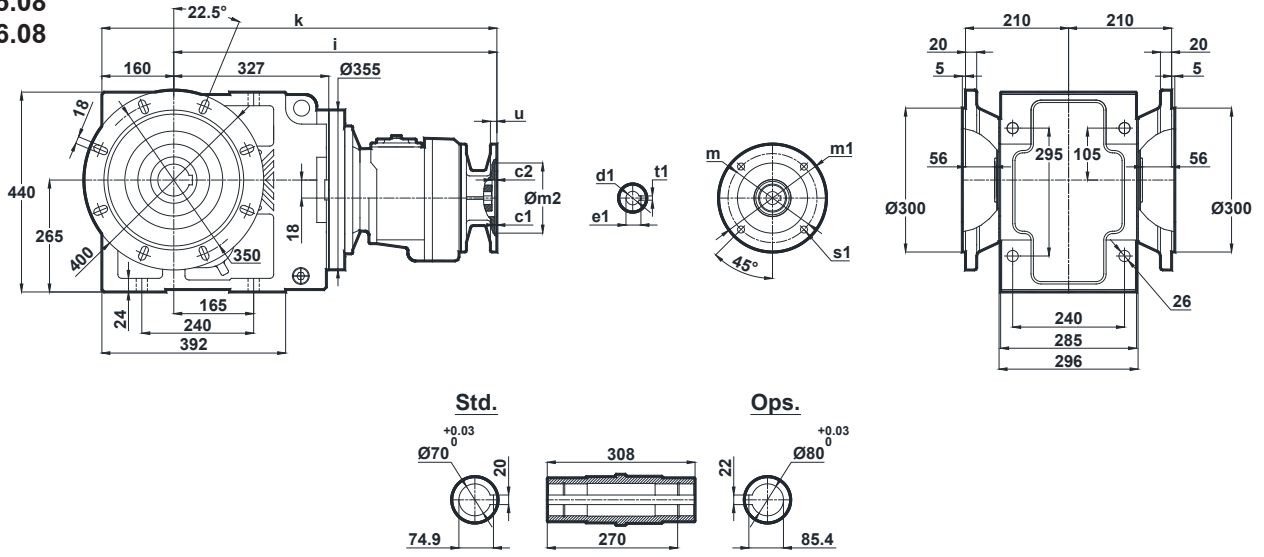

	c1	c2	s1	m	m1	m2	i	u	k	d1	t1	e1
71/B5	4	9	11	130	160	110	637	12	797	14	5	16.3
80/B5 80/B14	4	9	13 7	165 100	200 120	130 80	637	12	797	19	6	21.8
90/B5 90/B14	4	9	13 9	165 115	200 140	130 95	637	12	797	24	8	27.3 26.3

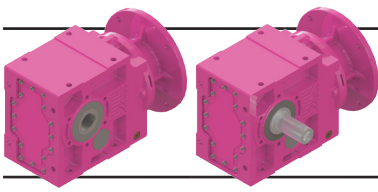

# Ölçü Sayfaları

## Dimension Pages

### Abmessungsseiten

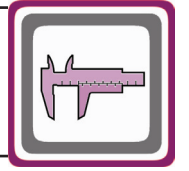

-Mil ucu çekirme deliği DIN 332 sayfa 2 / Tapped center hole to DIN 332, sheet 2 / Zentrierung mit Gewinde DIN 332, Blatt 2

#### KN773.00

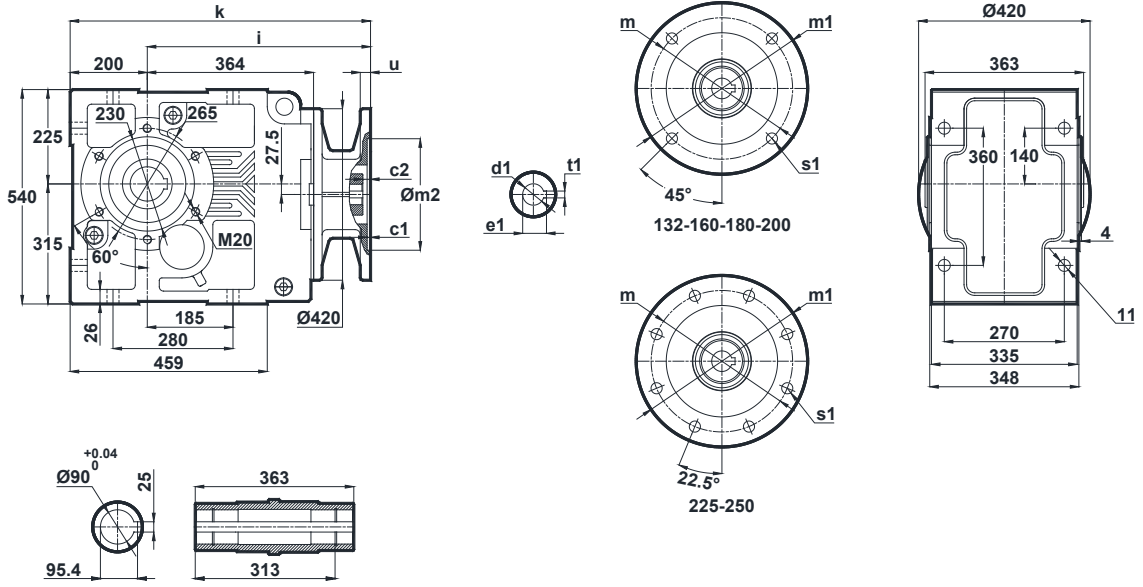

	c1	c2	s1	m	m1	m2	i	u	k	d1	t1	e1
132/B5	4.5	15	15	265	300	230	448	15	648	38	10	41.3
160/B5	5.5	10	19	300	350	250	517	20	717	42	12	45.3
180/B5	5.5	10	19	300	350	250	517	20	717	48	14	51.8
200/B5	5.5	10	19	350	400	300	539	20	739	55	16	59.3
225/B5	5.5	10	19	400	450	350	592	24	792	60	18	64.4
250/B5	5.5	10	19	500	550	450	592	24	792	65	18	69.4

#### KN773.01

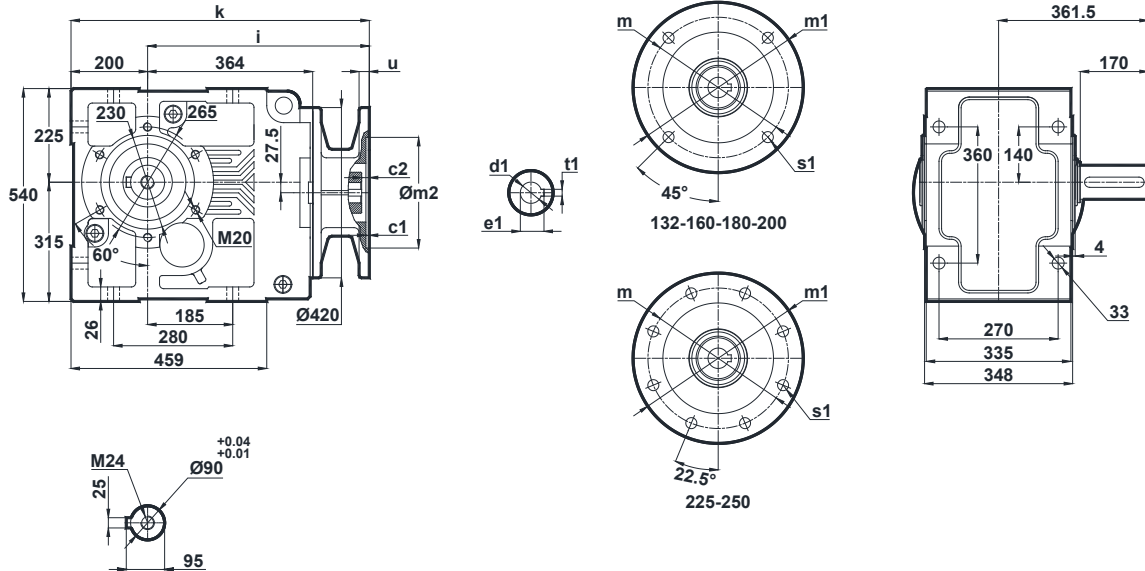

	c1	c2	s1	m	m1	m2	i	u	k	d1	t1	e1
132/B5	4.5	15	15	265	300	230	448	15	648	38	10	41.3
160/B5	5.5	10	19	300	350	250	517	20	717	42	12	45.3
180/B5	5.5	10	19	300	350	250	517	20	717	48	14	51.8
200/B5	5.5	10	19	350	400	300	539	20	739	55	16	59.3
225/B5	5.5	10	19	400	450	350	592	24	792	60	18	64.4
250/B5	5.5	10	19	500	550	450	592	24	792	65	18	69.4

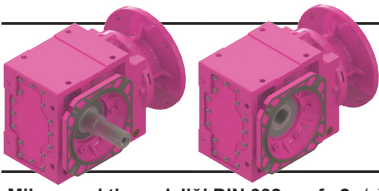

# Ölçü Sayfaları

## Dimension Pages

### Abmessungenseiten

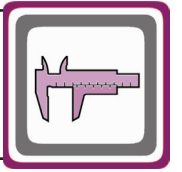

-Mil ucu çektirme deliği DIN 332 sayfa 2 / Tapped center hole to DIN 332, sheet 2 / Zentrierung mit Gewinde DIN 332, Blatt 2

#### KN773.02

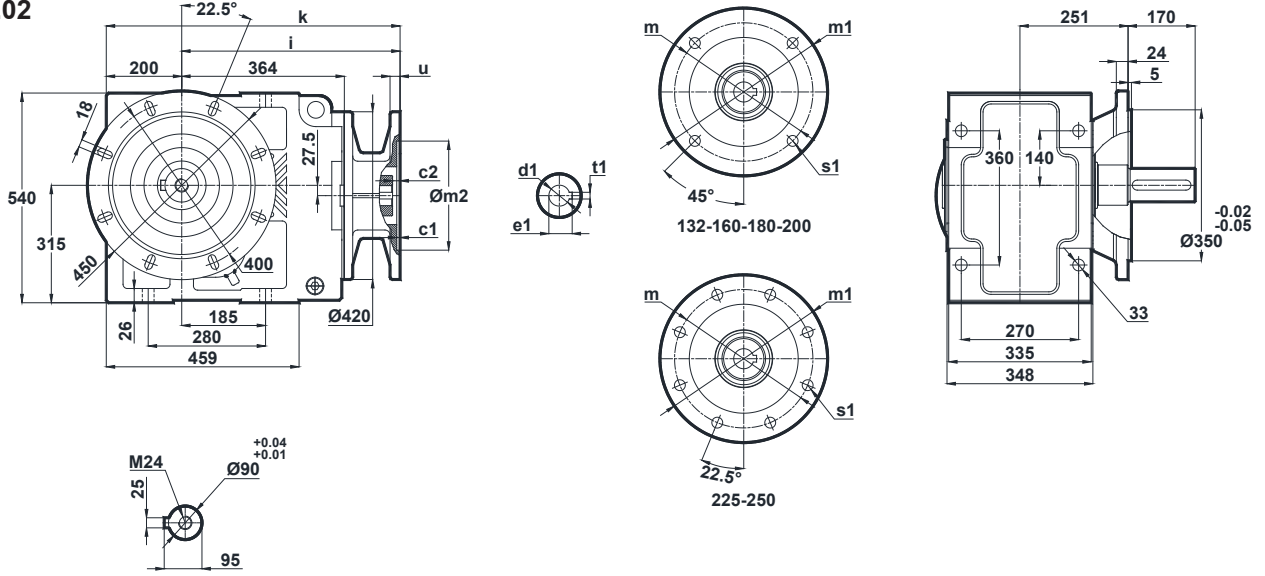

	c1	c2	s1	m	m1	m2	i	u	k	d1	t1	e1
132/B5	4.5	15	15	265	300	230	448	15	648	38	10	41.3
160/B5	5.5	10	19	300	350	250	517	20	717	42	12	45.3
180/B5	5.5	10	19	300	350	250	517	20	717	48	14	51.8
200/B5	5.5	10	19	350	400	300	539	20	739	55	16	59.3
225/B5	5.5	10	19	400	450	350	592	24	792	60	18	64.4
250/B5	5.5	10	19	500	550	450	592	24	792	65	18	69.4

#### KN773.03

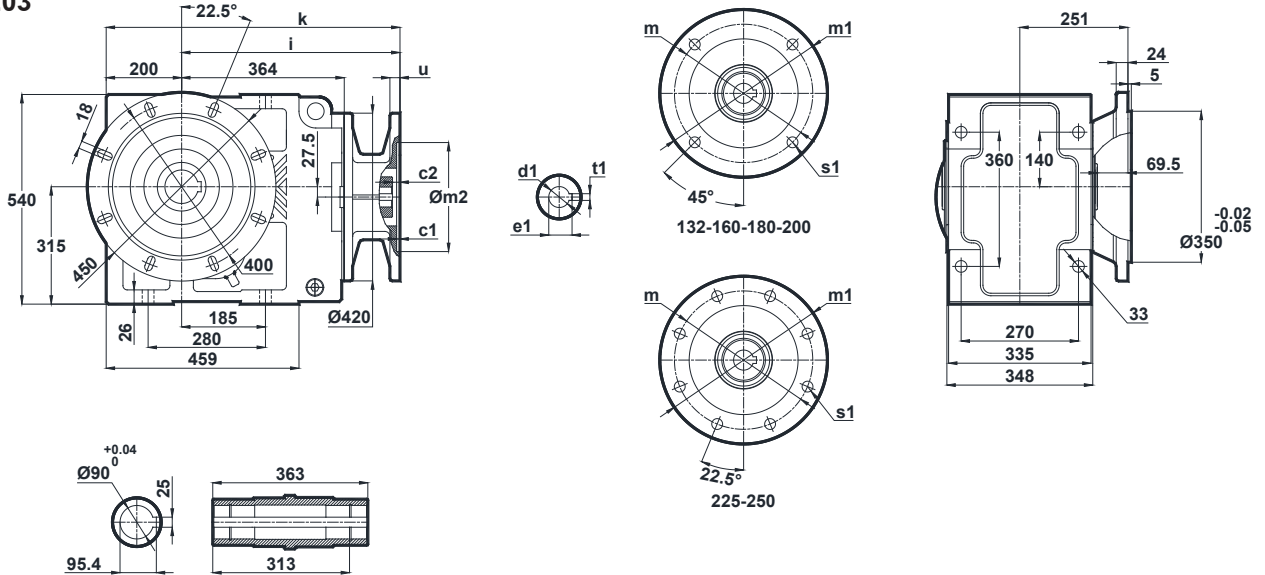

	c1	c2	s1	m	m1	m2	i	u	k	d1	t1	e1
132/B5	4.5	15	15	265	300	230	448	15	648	38	10	41.3
160/B5	5.5	10	19	300	350	250	517	20	717	42	12	45.3
180/B5	5.5	10	19	300	350	250	517	20	717	48	14	51.8
200/B5	5.5	10	19	350	400	300	539	20	739	55	16	59.3
225/B5	5.5	10	19	400	450	350	592	24	792	60	18	64.4
250/B5	5.5	10	19	500	550	450	592	24	792	65	18	69.4

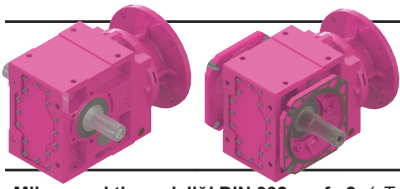

# Ölçü Sayfaları

## Dimension Pages

### Abmessungsseiten

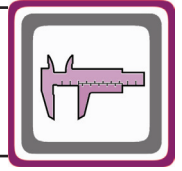

-Mil ucu çekirme deliği DIN 332 sayfa 2 / Tapped center hole to DIN 332, sheet 2 / Zentrierung mit Gewinde DIN 332, Blatt 2

#### KN773.04

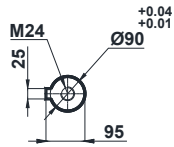
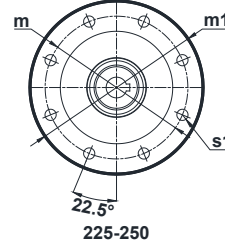
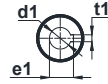
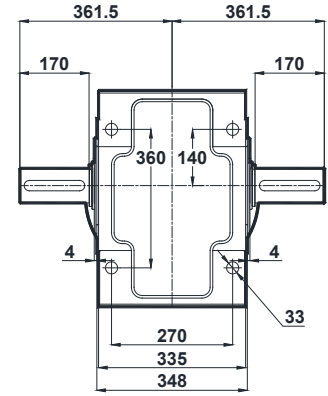
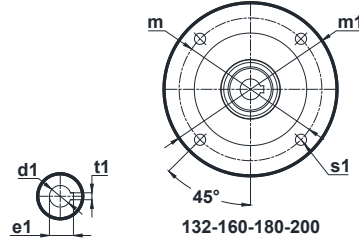
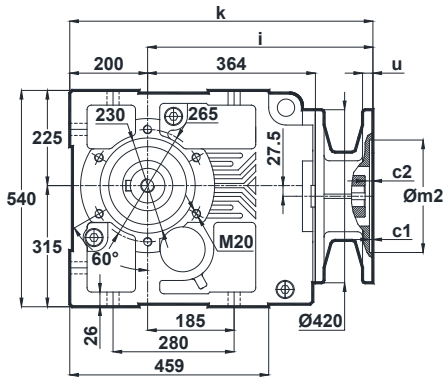

	c1	c2	s1	m	m1	m2	i	u	k	d1	t1	e1
132/B5	4.5	15	15	265	300	230	448	15	648	38	10	41.3
160/B5	5.5	10	19	300	350	250	517	20	717	42	12	45.3
180/B5	5.5	10	19	300	350	250	517	20	717	48	14	51.8
200/B5	5.5	10	19	350	400	300	539	20	739	55	16	59.3
225/B5	5.5	10	19	400	450	350	592	24	792	60	18	64.4
250/B5	5.5	10	19	500	550	450	592	24	792	65	18	69.4

#### KN773.05

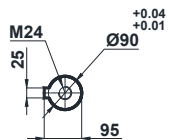
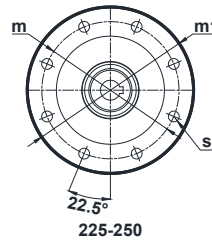
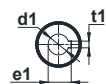
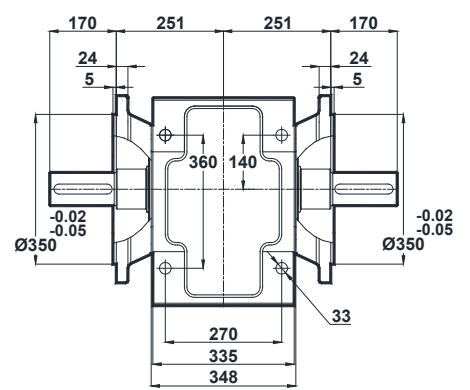
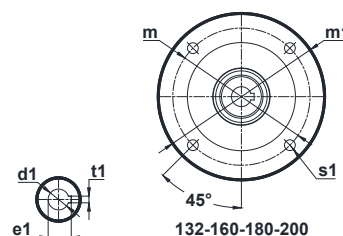
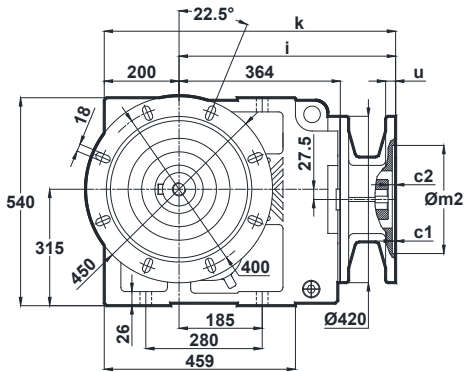

	c1	c2	s1	m	m1	m2	i	u	k	d1	t1	e1
132/B5	4.5	15	15	265	300	230	448	15	648	38	10	41.3
160/B5	5.5	10	19	300	350	250	517	20	717	42	12	45.3
180/B5	5.5	10	19	300	350	250	517	20	717	48	14	51.8
200/B5	5.5	10	19	350	400	300	539	20	739	55	16	59.3
225/B5	5.5	10	19	400	450	350	592	24	792	60	18	64.4
250/B5	5.5	10	19	500	550	450	592	24	792	65	18	69.4



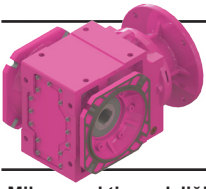

# Ölçü Sayfaları Dimension Pages Abmessungenseiten

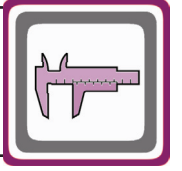

-Mil ucu çektirme deliği DIN 332 sayfa 2 / Tapped center hole to DIN 332, sheet 2 / Zentrierung mit Gewinde DIN 332, Blatt 2

KN773.08

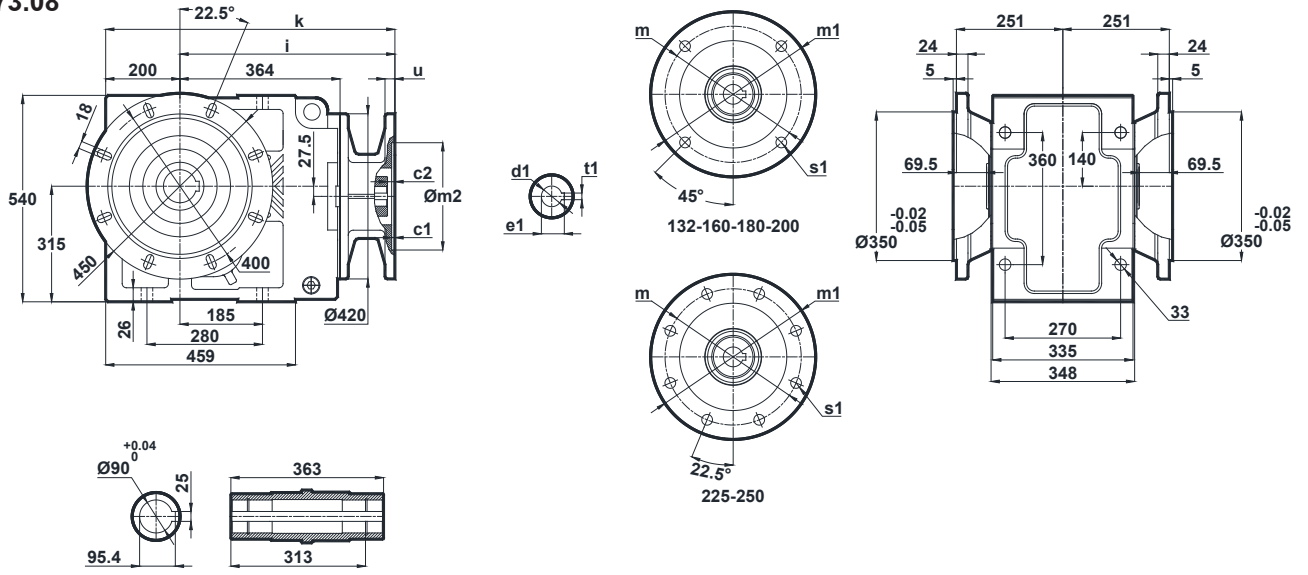

	c1	c2	s1	m	m1	m2	i	u	k	d1	t1	e1
132/B5	4.5	15	15	265	300	230	448	15	648	38	10	41.3
160/B5	5.5	10	19	300	350	250	517	20	717	42	12	45.3
180/B5	5.5	10	19	300	350	250	517	20	717	48	14	51.8
200/B5	5.5	10	19	350	400	300	539	20	739	55	16	59.3
225/B5	5.5	10	19	400	450	350	592	24	792	60	18	64.4
250/B5	5.5	10	19	500	550	450	592	24	792	65	18	69.4

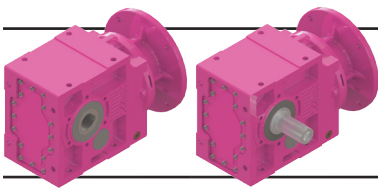

# Ölçü Sayfaları

## Dimension Pages

### Abmessungsseiten

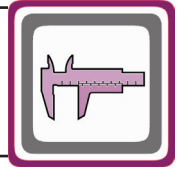

-Mil ucu çekirme deliği DIN 332 sayfa 2 / Tapped center hole to DIN 332, sheet 2 / Zentrierung mit Gewinde DIN 332, Blatt 2

#### KN774.00

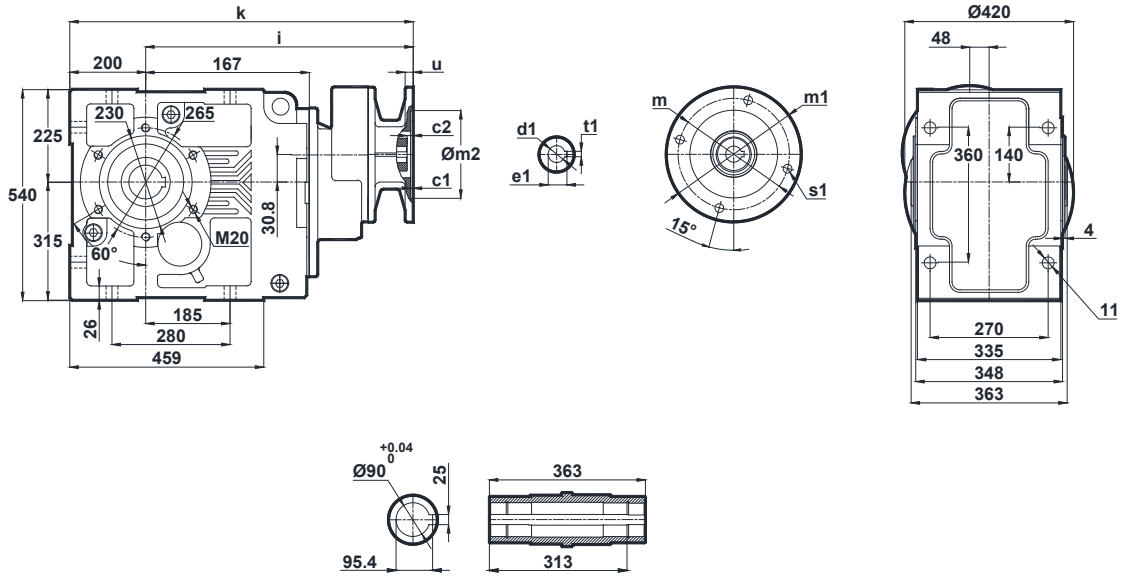

	c1	c2	s1	m	m1	m2	i	u	k	d1	t1	e1
90/B5	4	5	12	165	200	130	523	12	723	24	8	27.3
90/B14	9	9	9	115	140	95						
100/B5	4.5	9	15	215	250	180	541	15	741	28	8	31.3
100/B14	3.5	9	9	130	160	110						
112/B5	4.5	9	15	215	250	180	560	15	741	28	8	31.3
112/B14	3.5	9	9	130	160	110						
132/B5	4.5	6	15	265	300	230	639	15	760	38	10	41.3
132/B14	6	6	11	165	200	130						

#### KN774.01

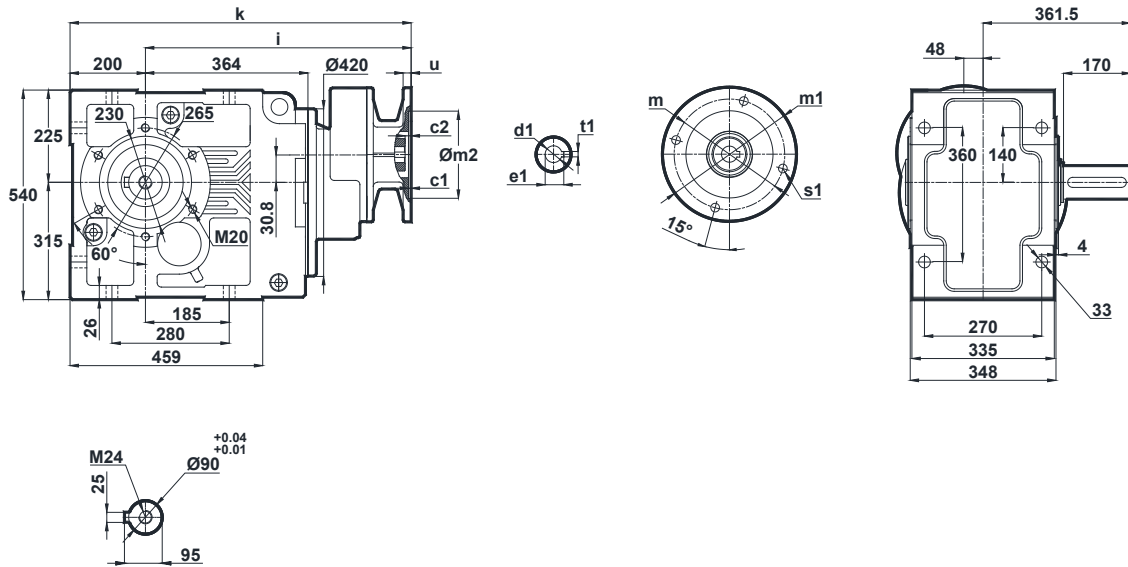

	c1	c2	s1	m	m1	m2	i	u	k	d1	t1	e1
90/B5	4	5	12	165	200	130	523	12	723	24	8	27.3
90/B14	9	9	9	115	140	95						
100/B5	4.5	9	15	215	250	180	541	15	741	28	8	31.3
100/B14	3.5	9	9	130	160	110						
112/B5	4.5	9	15	215	250	180	560	15	741	28	8	31.3
112/B14	3.5	9	9	130	160	110						
132/B5	4.5	6	15	265	300	230	639	15	760	38	10	41.3
132/B14	6	6	11	165	200	130						

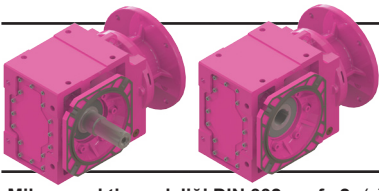

# Ölçü Sayfaları

## Dimension Pages

### Abmessungsseiten

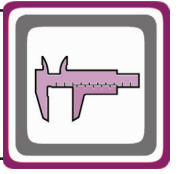

-Mil ucu çektirme deliği DIN 332 sayfa 2 / Tapped center hole to DIN 332, sheet 2 / Zentrierung mit Gewinde DIN 332, Blatt 2

#### KN774.02

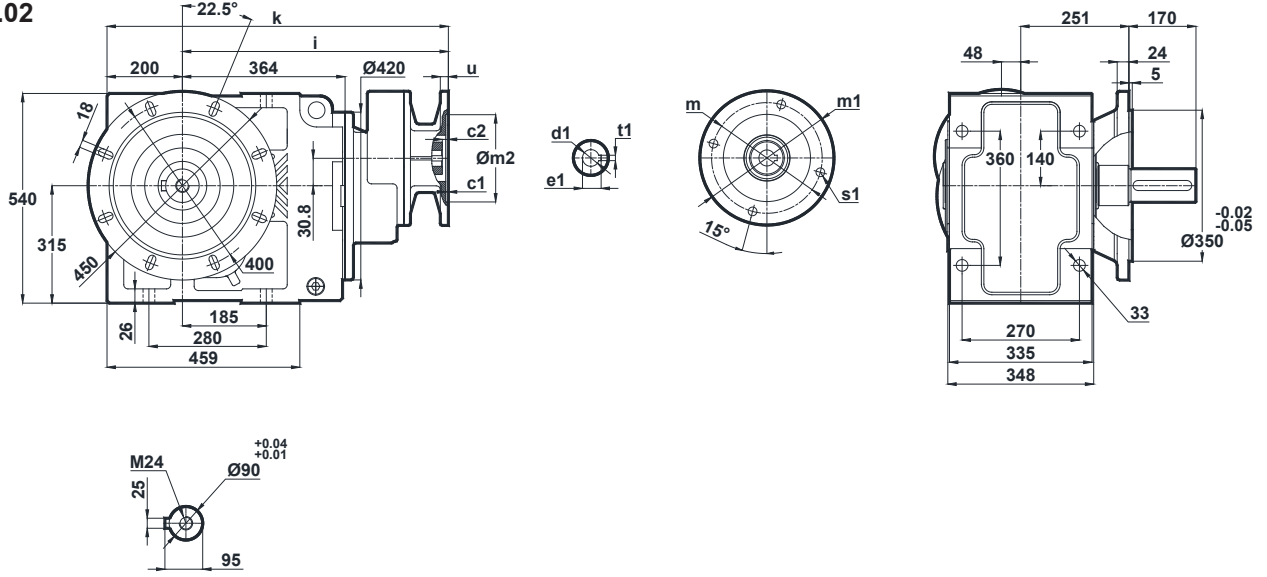

	c1	c2	s1	m	m1	m2	i	u	k	d1	t1	e1
90/B5	4	5	12	165	200	130	523	12	723	24	8	27.3
90/B14			9	115	140	95						
100/B5	4.5	9	15	215	250	180	541	15	741	28	8	31.3
100/B14	3.5		9	130	160	110						
112/B5	4.5	9	15	215	250	180	560	15	741	28	8	31.3
112/B14	3.5		9	130	160	110						
132/B5	4.5	6	15	265	300	230	639	15	760	38	10	41.3
132/B14			11	165	200	130						

#### KN774.03

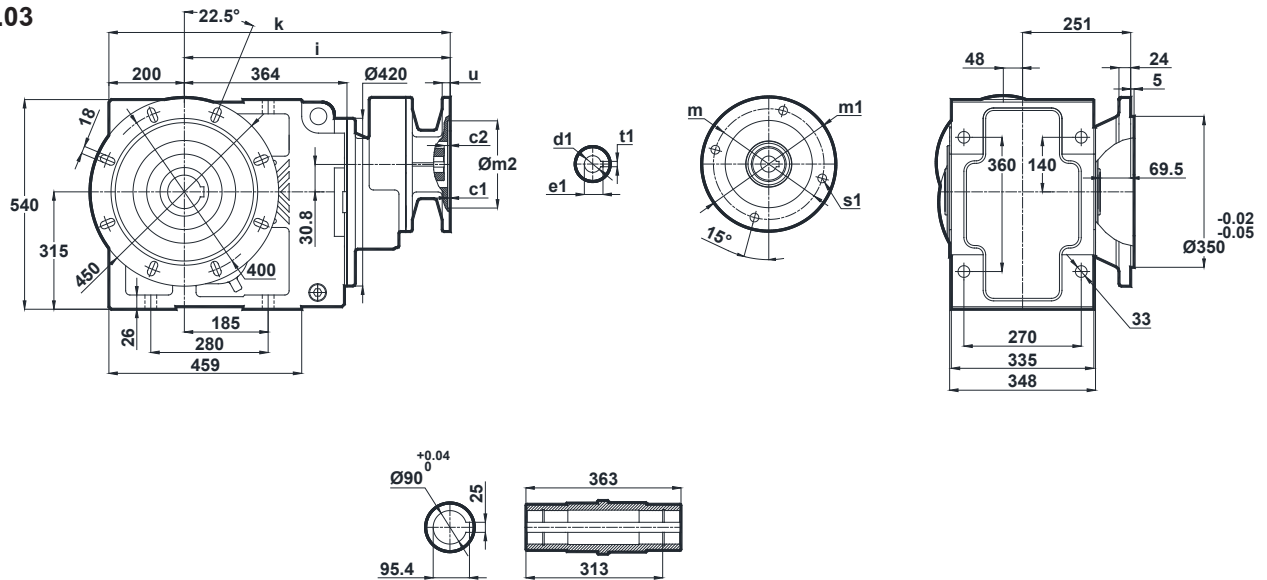

	c1	c2	s1	m	m1	m2	i	u	k	d1	t1	e1
90/B5	4	5	12	165	200	130	523	12	723	24	8	27.3
90/B14			9	115	140	95						
100/B5	4.5	9	15	215	250	180	541	15	741	28	8	31.3
100/B14	3.5		9	130	160	110						
112/B5	4.5	9	15	215	250	180	560	15	741	28	8	31.3
112/B14	3.5		9	130	160	110						
132/B5	4.5	6	15	265	300	230	639	15	760	38	10	41.3
132/B14			11	165	200	130						

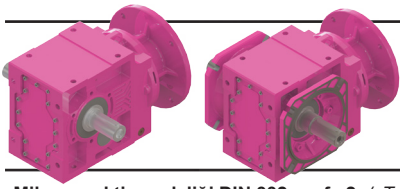

# Ölçü Sayfaları

## Dimension Pages

### Abmessungsseiten

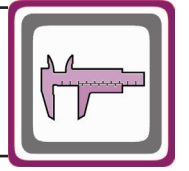

-Mil ucu çekirme deliği DIN 332 sayfa 2 / Tapped center hole to DIN 332, sheet 2 / Zentrierung mit Gewinde DIN 332, Blatt 2

#### KN774.04

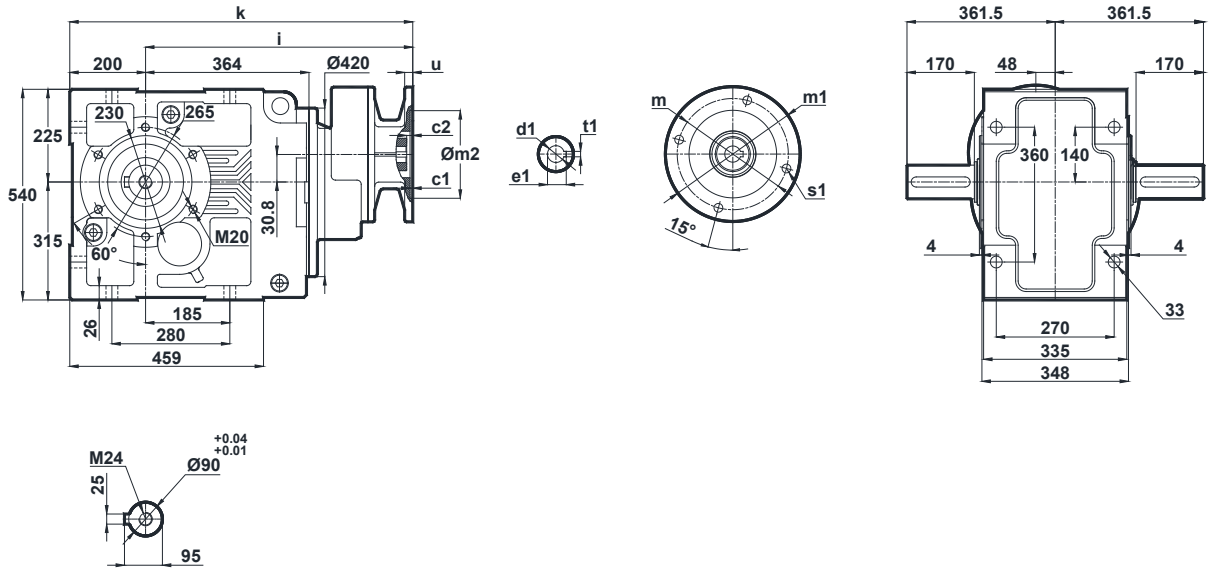

	c1	c2	s1	m	m1	m2	i	u	k	d1	t1	e1
90/B5	4	5	12	165	200	130	523	12	723	24	8	27.3
90/B14	9	9	9	115	140	95						
100/B5	4.5	9	15	215	250	180	541	15	741	28	8	31.3
100/B14	3.5	9	9	130	160	110						
112/B5	4.5	9	15	215	250	180	560	15	741	28	8	31.3
112/B14	3.5	9	9	130	160	110						
132/B5	4.5	6	15	265	300	230	639	15	760	38	10	41.3
132/B14	4.5	6	11	165	200	130						

#### KN774.05

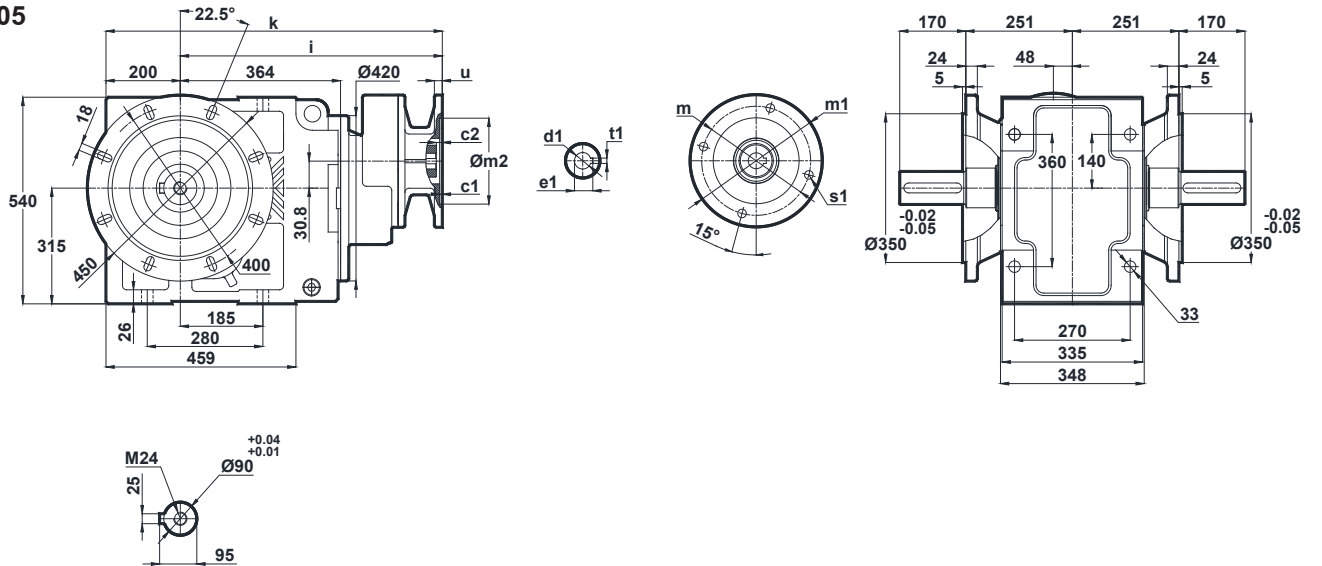

	c1	c2	s1	m	m1	m2	i	u	k	d1	t1	e1
90/B5	4	5	12	165	200	130	523	12	723	24	8	27.3
90/B14	9	9	9	115	140	95						
100/B5	4.5	9	15	215	250	180	541	15	741	28	8	31.3
100/B14	3.5	9	9	130	160	110						
112/B5	4.5	9	15	215	250	180	560	15	741	28	8	31.3
112/B14	3.5	9	9	130	160	110						
132/B5	4.5	6	15	265	300	230	639	15	760	38	10	41.3
132/B14	4.5	6	11	165	200	130						

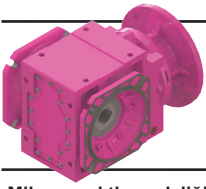

# Ölçü Sayfaları Dimension Pages Abmessungsseiten

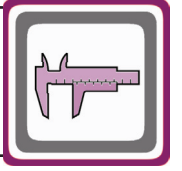

-Mil ucu çekirme deliği DIN 332 sayfa 2 / Tapped center hole to DIN 332, sheet 2 / Zentrierung mit Gewinde DIN 332, Blatt 2

KN774.08

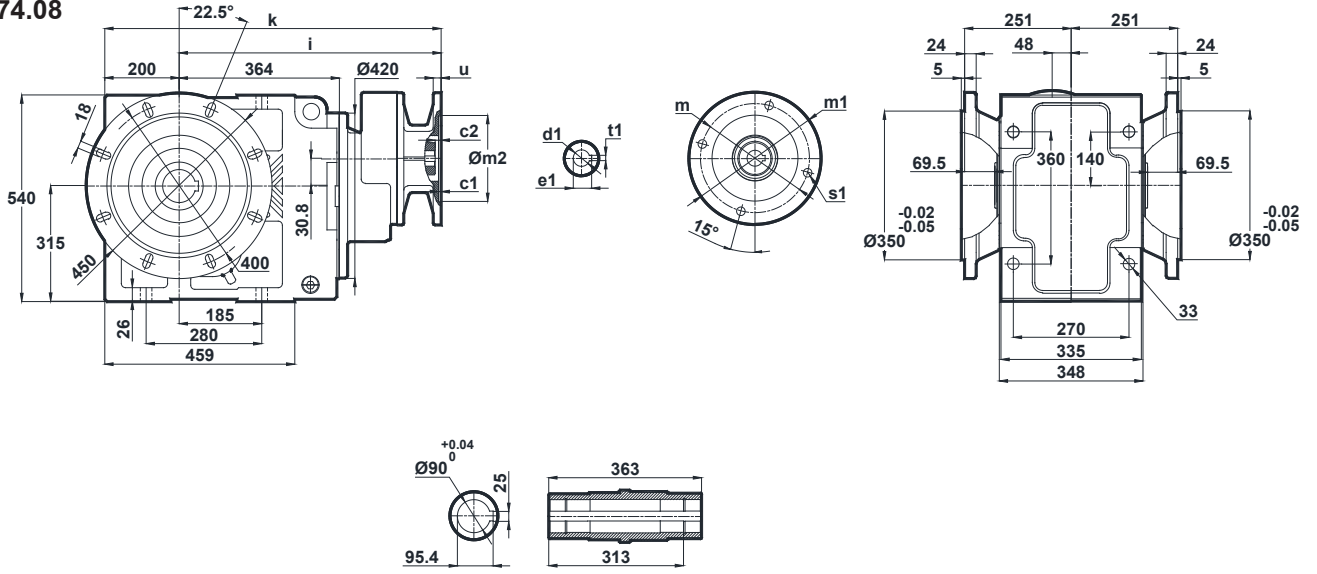

	c1	c2	s1	m	m1	m2	i	u	k	d1	t1	e1
90/B5	4	5	12	165	200	130	523	12	723	24	8	27.3
90/B14	4	5	9	115	140	95	523	12	723	24	8	27.3
100/B5	4.5	9	15	215	250	180	541	15	741	28	8	31.3
100/B14	3.5	9	9	130	160	110	541	15	741	28	8	31.3
112/B5	4.5	9	15	215	250	180	560	15	741	28	8	31.3
112/B14	3.5	9	9	130	160	110	560	15	741	28	8	31.3
132/B5	4.5	6	15	265	300	230	639	15	760	38	10	41.3
132/B14	4.5	6	11	165	200	130	639	15	760	38	10	41.3

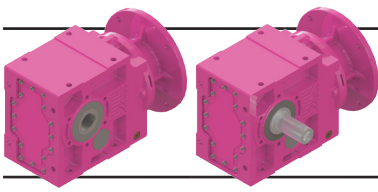

# Ölçü Sayfaları

## Dimension Pages

### Abmessungsseiten

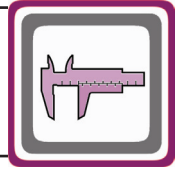

-Mil ucu çektirme deliği DIN 332 sayfa 2 / Tapped center hole to DIN 332, sheet 2 / Zentrierung mit Gewinde DIN 332, Blatt 2

KN775.00  
KN776.00

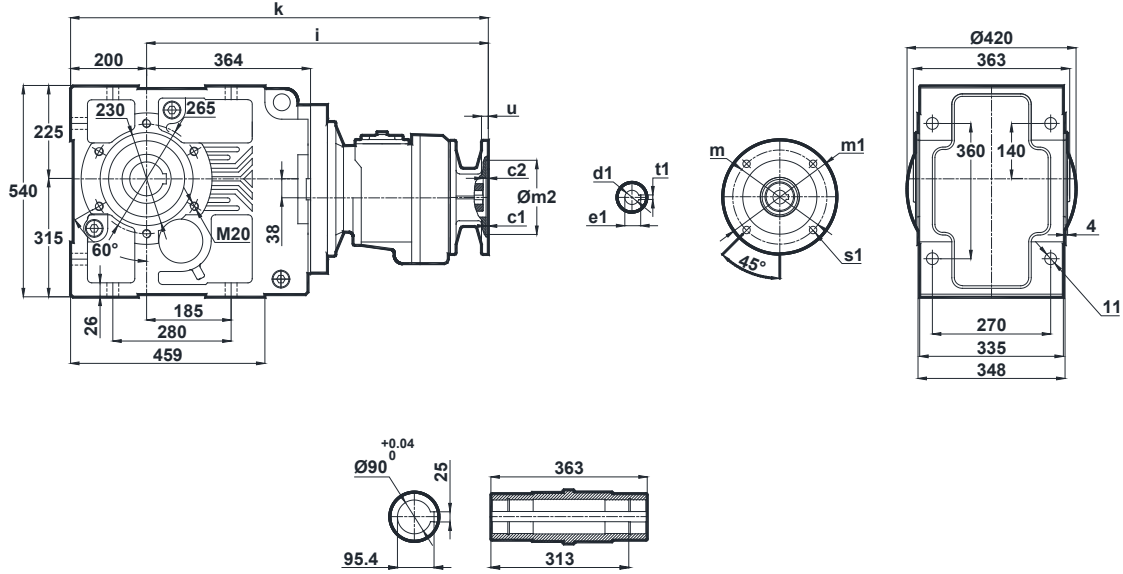

	c1	c2	s1	m	m1	m2	i	u	k	d1	t1	e1
71/B5	4	9	11	130	160	110	674	12	874	14	5	16.3
80/B5	4	9	12	165	200	130	674	12	874	19	6	21.8
80/B14	4	9	7	100	120	80	674	12	874	19	6	21.8
90/B5	4	9	12	165	200	130	674	12	874	24	8	27.3
90/B14	4	9	9	115	140	90	674	12	874	24	8	26.3
100/B5	4.5	9	15	215	250	180	691	15	891	28	8	31.3
100/B14	3.5	9	9	130	160	110	691	15	891	28	8	31.3

KN775.01  
KN776.01

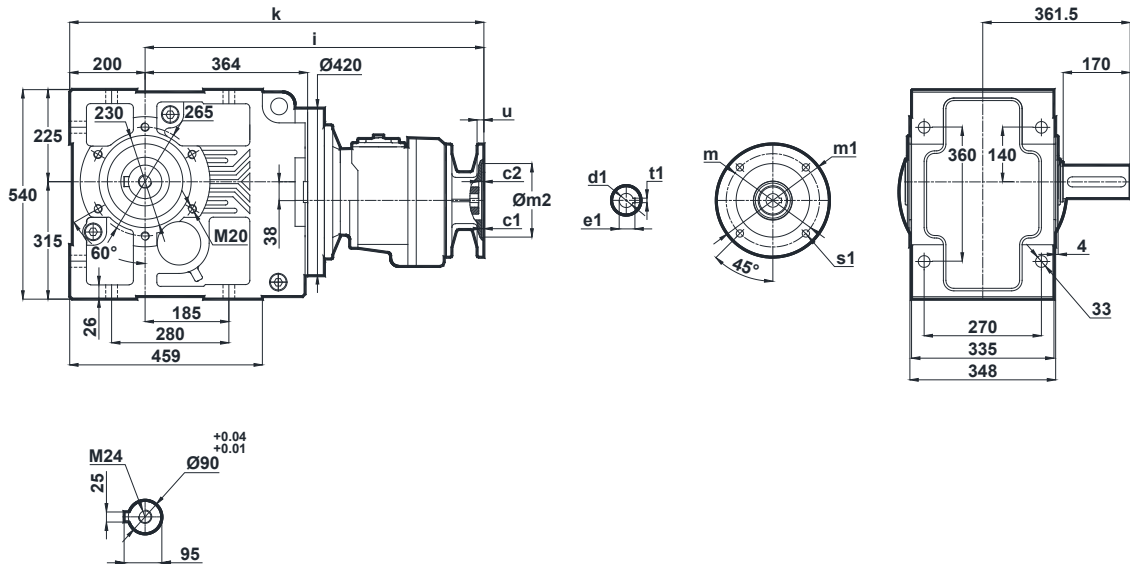

	c1	c2	s1	m	m1	m2	i	u	k	d1	t1	e1
71/B5	4	9	11	130	160	110	674	12	874	14	5	16.3
80/B5	4	9	12	165	200	130	674	12	874	19	6	21.8
80/B14	4	9	7	100	120	80	674	12	874	19	6	21.8
90/B5	4	9	12	165	200	130	674	12	874	24	8	27.3
90/B14	4	9	9	115	140	90	674	12	874	24	8	26.3
100/B5	4.5	9	15	215	250	180	691	15	891	28	8	31.3
100/B14	3.5	9	9	130	160	110	691	15	891	28	8	31.3

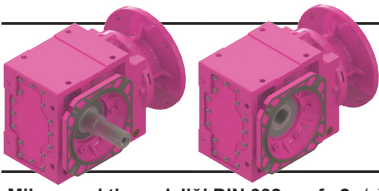

# Ölçü Sayfaları

## Dimension Pages

### Abmessungsseiten

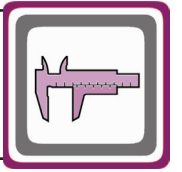

-Mil ucu çektirme deliği DIN 332 sayfa 2 / Tapped center hole to DIN 332, sheet 2 / Zentrierung mit Gewinde DIN 332, Blatt 2

KN775.02  
KN776.02

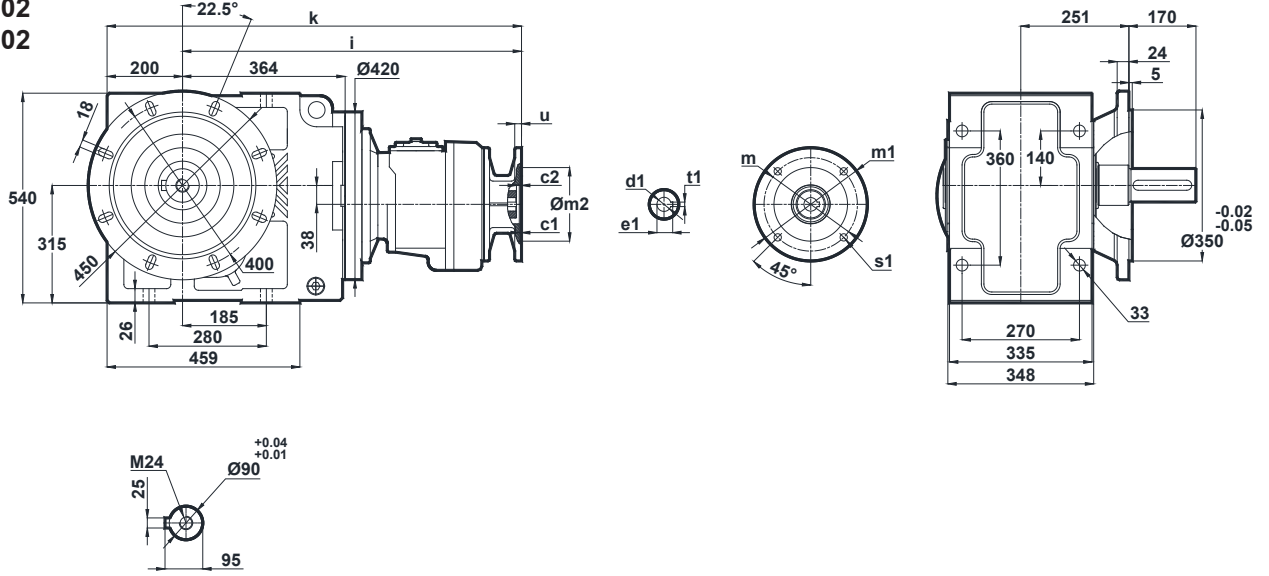

	c1	c2	s1	m	m1	m2	i	u	k	d1	t1	e1
71/B5	4	9	11	130	160	110	674	12	874	14	5	16.3
80/B5 80/B14	4	9	12 7	165 100	200 120	130 80	674	12	874	19	6	21.8
90/B5 90/B14	4	9	12 9	165 115	200 140	130 90	674	12	874	24	8	27.3 26.3
100/B5 100/B14	4.5 3.5	9	15 9	215 130	250 160	180 110	691	15	891	28	8	31.3

KN775.03  
KN776.03

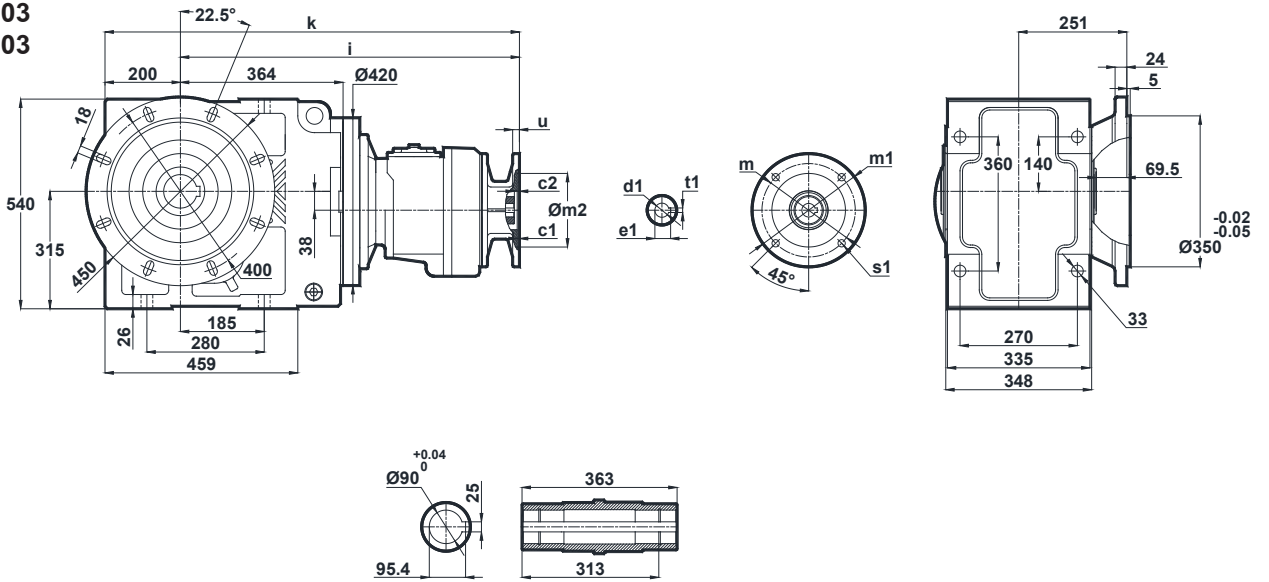

	c1	c2	s1	m	m1	m2	i	u	k	d1	t1	e1
71/B5	4	9	11	130	160	110	674	12	874	14	5	16.3
80/B5 80/B14	4	9	12 7	165 100	200 120	130 80	674	12	874	19	6	21.8
90/B5 90/B14	4	9	12 9	165 115	200 140	130 90	674	12	874	24	8	27.3 26.3
100/B5 100/B14	4.5 3.5	9	15 9	215 130	250 160	180 110	691	15	891	28	8	31.3

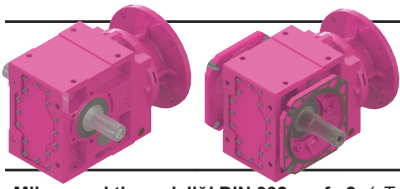

# Ölçü Sayfaları

## Dimension Pages

### Abmessungsseiten

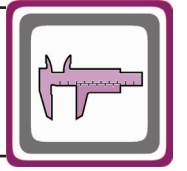

-Mil ucu çekirme deliği DIN 332 sayfa 2 / Tapped center hole to DIN 332, sheet 2 / Zentrierung mit Gewinde DIN 332, Blatt 2

KN775.04  
KN776.04

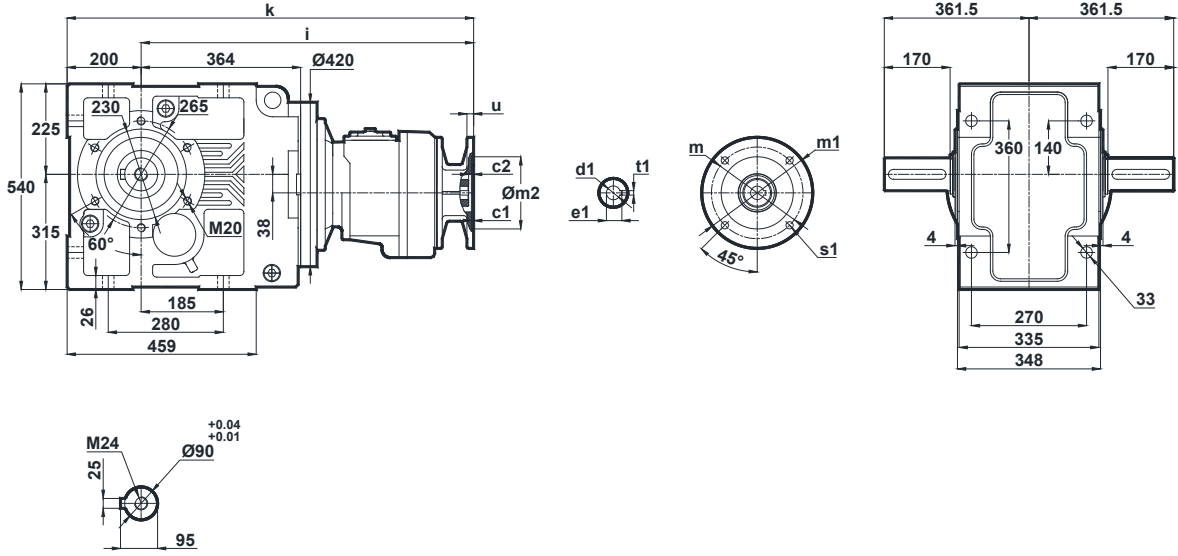

	c1	c2	s1	m	m1	m2	i	u	k	d1	t1	e1
71/B5	4	9	11	130	160	110	674	12	874	14	5	16.3
80/B5	4	9	12	165	200	130	674	12	874	19	6	21.8
80/B14	4	9	7	100	120	80	674	12	874	19	6	21.8
90/B5	4	9	12	165	200	130	674	12	874	24	8	27.3
90/B14	4	9	9	115	140	90	674	12	874	24	8	26.3
100/B5	4.5	9	15	215	250	180	691	15	891	28	8	31.3
100/B14	3.5	9	9	130	160	110	691	15	891	28	8	31.3

KN775.05  
KN776.05

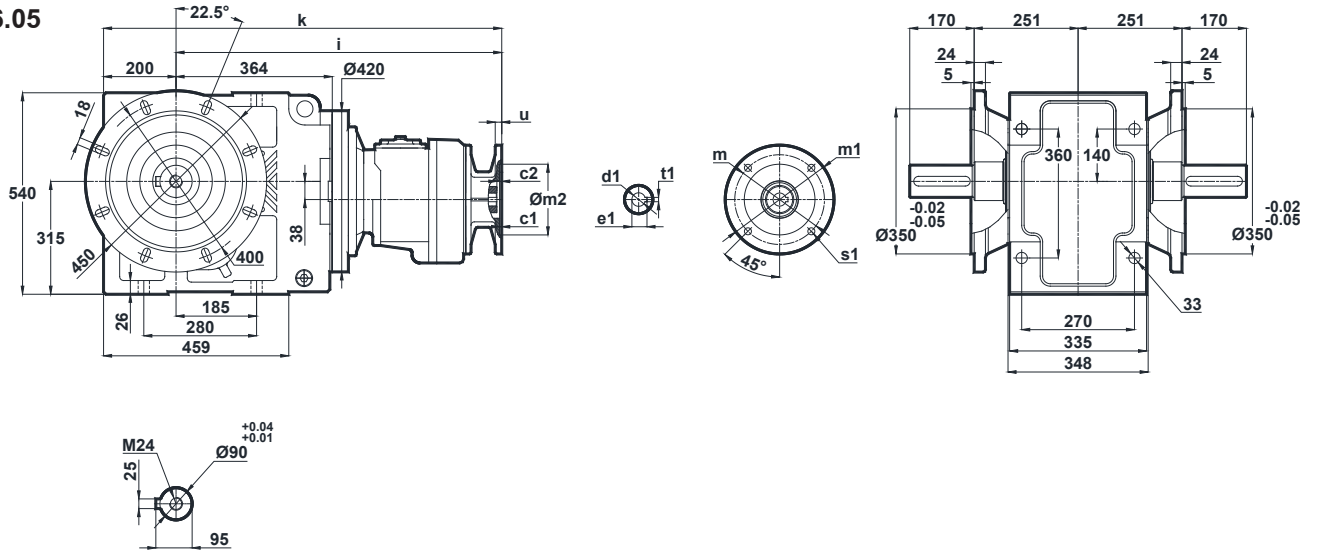

	c1	c2	s1	m	m1	m2	i	u	k	d1	t1	e1
71/B5	4	9	11	130	160	110	674	12	874	14	5	16.3
80/B5	4	9	12	165	200	130	674	12	874	19	6	21.8
80/B14	4	9	7	100	120	80	674	12	874	19	6	21.8
90/B5	4	9	12	165	200	130	674	12	874	24	8	27.3
90/B14	4	9	9	115	140	90	674	12	874	24	8	26.3
100/B5	4.5	9	15	215	250	180	691	15	891	28	8	31.3
100/B14	3.5	9	9	130	160	110	691	15	891	28	8	31.3



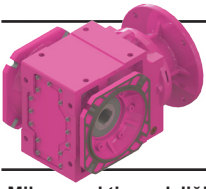

# Ölçü Sayfaları

## Dimension Pages

### Abmessungsseiten

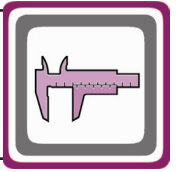

-Mil ucu çekirme deliği DIN 332 sayfa 2 / Tapped center hole to DIN 332, sheet 2 / Zentrierung mit Gewinde DIN 332, Blatt 2

KN775.08  
KN776.08

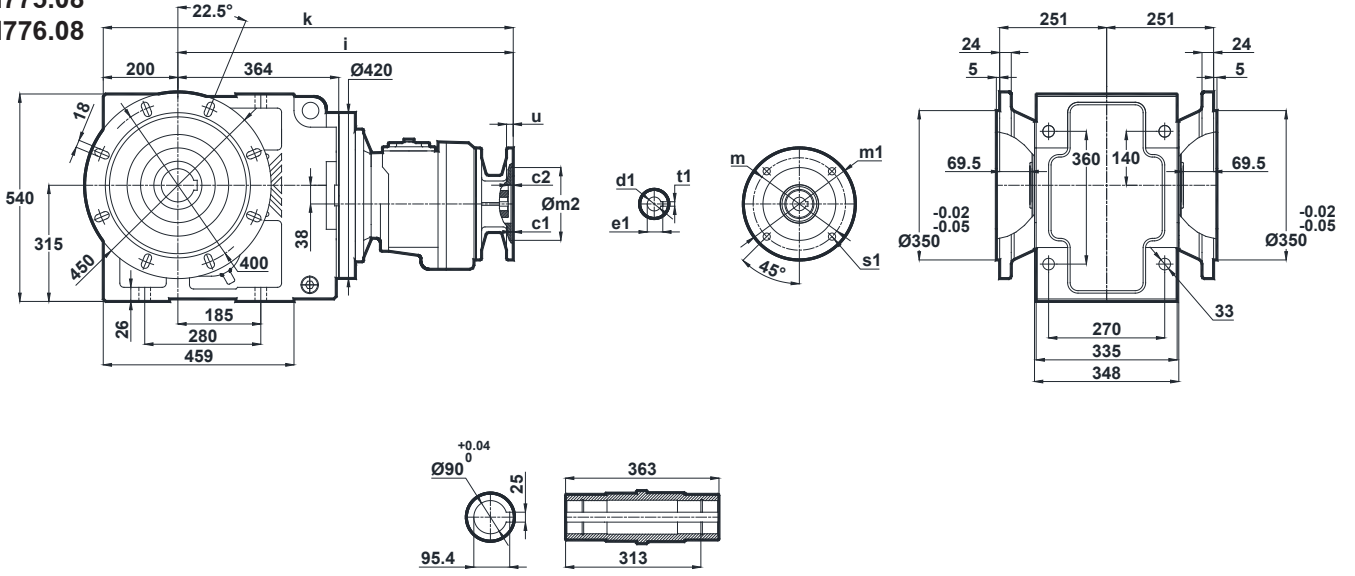

	c1	c2	s1	m	m1	m2	i	u	k	d1	t1	e1
71/B5	4	9	11	130	160	110	674	12	874	14	5	16.3
80/B5	4	9	12	165	200	130	674	12	874	19	6	21.8
80/B14	4	9	7	100	120	80	674	12	874	19	6	21.8
90/B5	4	9	12	165	200	130	674	12	874	24	8	27.3
90/B14	4	9	9	115	140	90	674	12	874	24	8	26.3
100/B5	4.5	9	15	215	250	180	691	15	891	28	8	31.3
100/B14	3.5	9	9	130	160	110	691	15	891	28	8	31.3

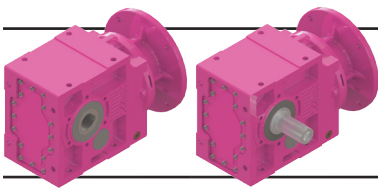

# Ölçü Sayfaları

## Dimension Pages

### Abmessungsseiten

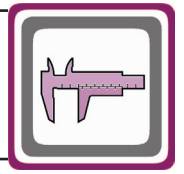

-Mil ucu çekirme deliği DIN 332 sayfa 2 / Tapped center hole to DIN 332, sheet 2 / Zentrierung mit Gewinde DIN 332, Blatt 2

#### KN873.00

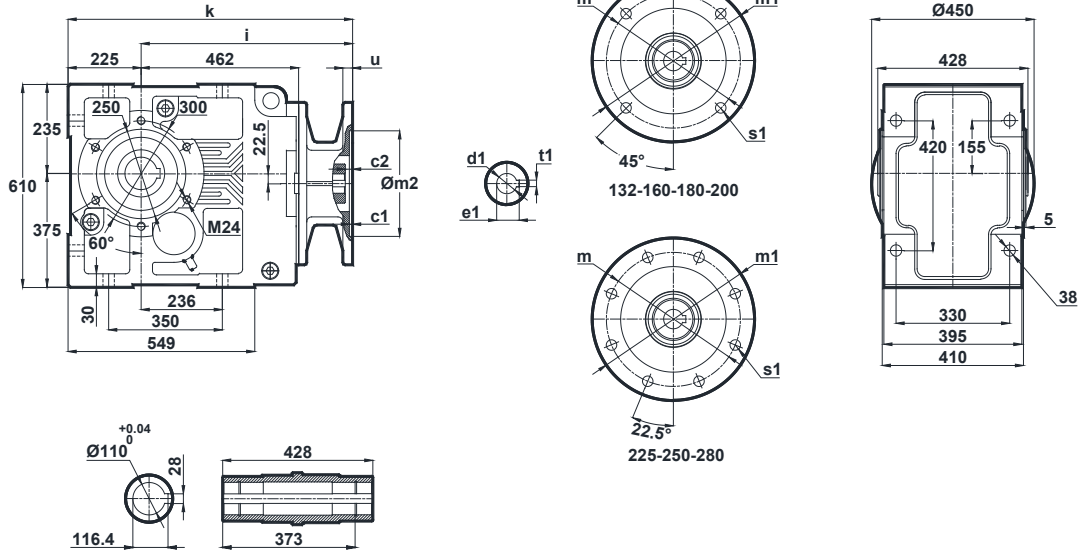

	c1	c2	s1	m	m1	m2	i	u	k	d1	t1	e1
132/B5	4.5	14	15	265	300	230	535	15	760	38	10	41.3
160/B5	5.5	10	19	300	350	250	680	20	905	42	12	45.3
180/B5	5.5	10	19	300	350	250	680	20	905	48	14	51.8
200/B5	5.5	10	19	350	400	300	680	22	905	55	16	59.3
225/B5	5.5	10	19	400	450	350	680	24	905	60	18	64.4
250/B5	5.5	10	19	500	550	450	680	24	905	65	18	69.4
280/B5	5.5	10	19	500	550	450	680	24	905	75	20	79.9

#### KN873.01

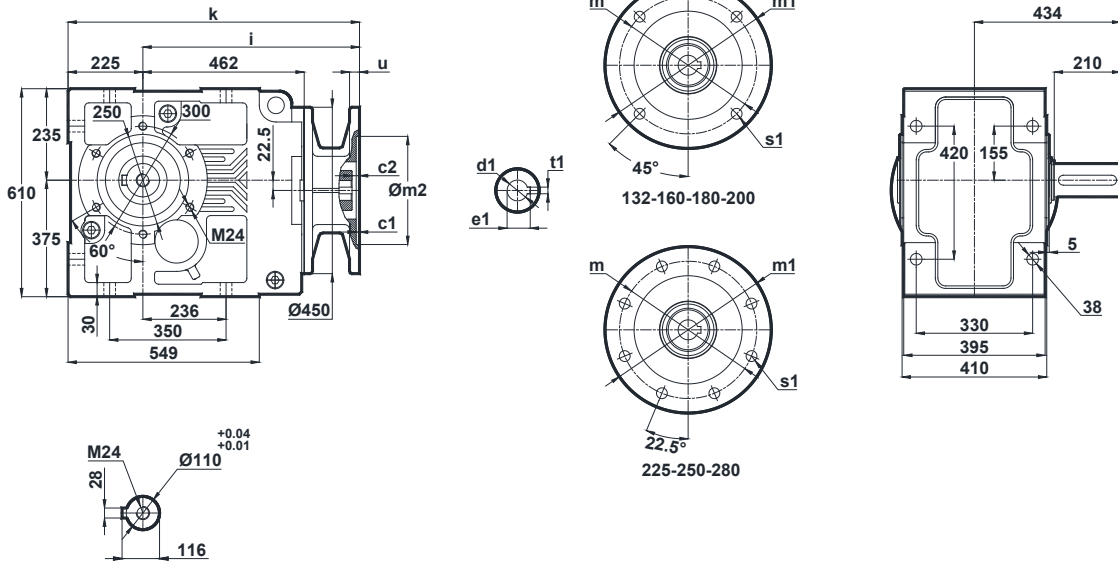

	c1	c2	s1	m	m1	m2	i	u	k	d1	t1	e1
132/B5	4.5	14	15	265	300	230	535	15	760	38	10	41.3
160/B5	5.5	10	19	300	350	250	680	20	905	42	12	45.3
180/B5	5.5	10	19	300	350	250	680	20	905	48	14	51.8
200/B5	5.5	10	19	350	400	300	680	22	905	55	16	59.3
225/B5	5.5	10	19	400	450	350	680	24	905	60	18	64.4
250/B5	5.5	10	19	500	550	450	680	24	905	65	18	69.4
280/B5	5.5	10	19	500	550	450	680	24	905	75	20	79.9

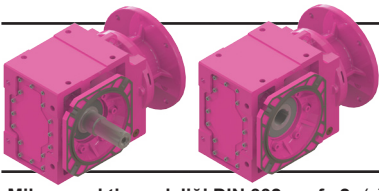

# Ölçü Sayfaları

## Dimension Pages

### Abmessungsseiten

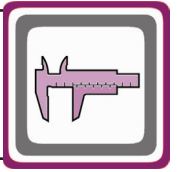

-Mil ucu çekirme deliği DIN 332 sayfa 2 / Tapped center hole to DIN 332, sheet 2 / Zentrierung mit Gewinde DIN 332, Blatt 2

#### KN873.02

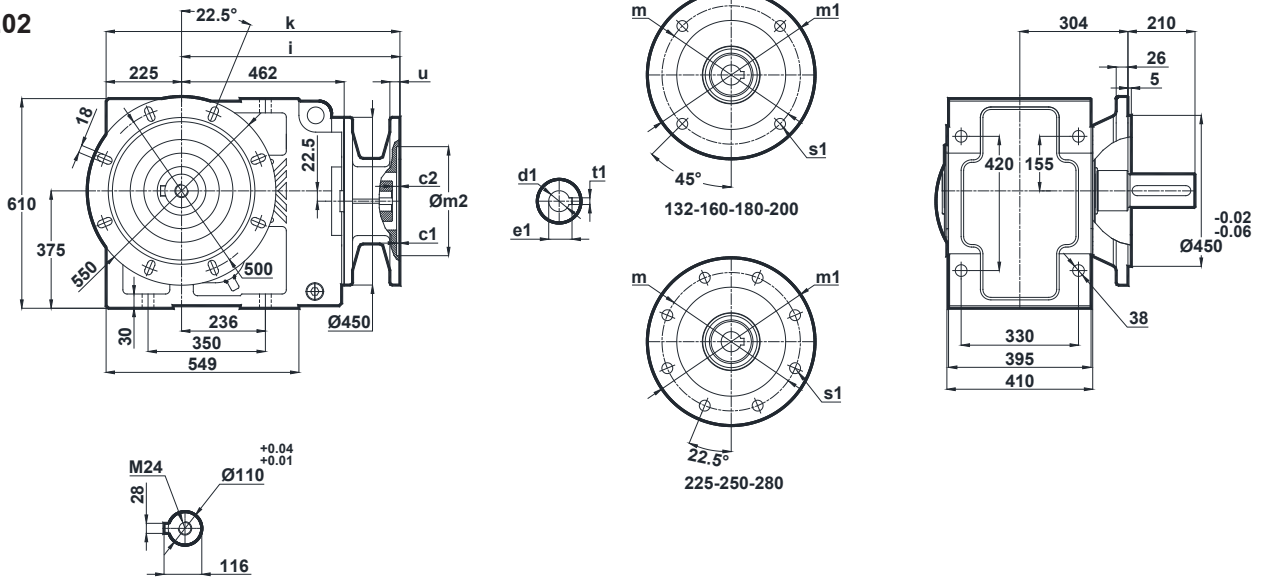

	c1	c2	s1	m	m1	m2	i	u	k	d1	t1	e1
132/B5	4.5	14	15	265	300	230	535	15	760	38	10	41.3
160/B5	5.5	10	19	300	350	250	680	20	905	42	12	45.3
180/B5	5.5	10	19	300	350	250	680	20	905	48	14	51.8
200/B5	5.5	10	19	350	400	300	680	22	905	55	16	59.3
225/B5	5.5	10	19	400	450	350	680	24	905	60	18	64.4
250/B5	5.5	10	19	500	550	450	680	24	905	65	18	69.4
280/B5	5.5	10	19	500	550	450	680	24	905	75	20	79.9

#### KN873.03

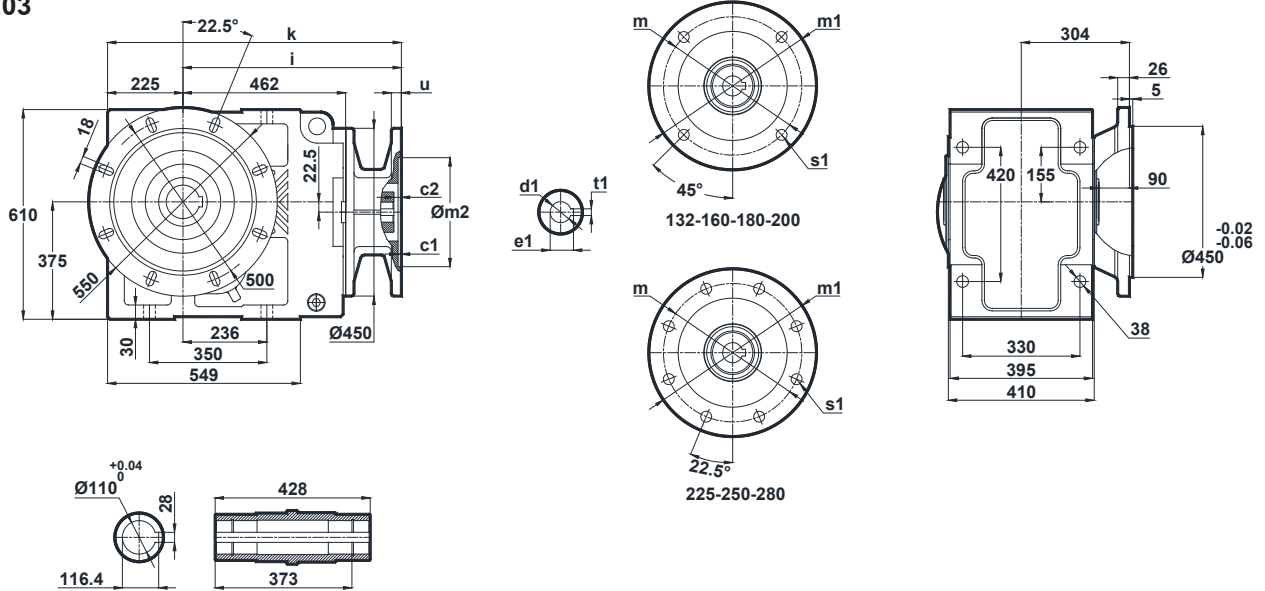

	c1	c2	s1	m	m1	m2	i	u	k	d1	t1	e1
132/B5	4.5	14	15	265	300	230	535	15	760	38	10	41.3
160/B5	5.5	10	19	300	350	250	680	20	905	42	12	45.3
180/B5	5.5	10	19	300	350	250	680	20	905	48	14	51.8
200/B5	5.5	10	19	350	400	300	680	22	905	55	16	59.3
225/B5	5.5	10	19	400	450	350	680	24	905	60	18	64.4
250/B5	5.5	10	19	500	550	450	680	24	905	65	18	69.4
280/B5	5.5	10	19	500	550	450	680	24	905	75	20	79.9

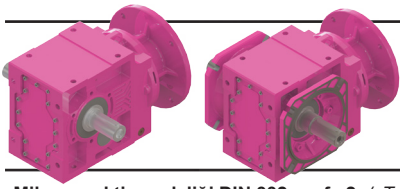

# Ölçü Sayfaları

## Dimension Pages

### Abmessungsseiten

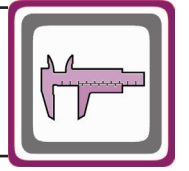

-Mil ucu çekirme deliği DIN 332 sayfa 2 / Tapped center hole to DIN 332, sheet 2 / Zentrierung mit Gewinde DIN 332, Blatt 2

#### KN873.04

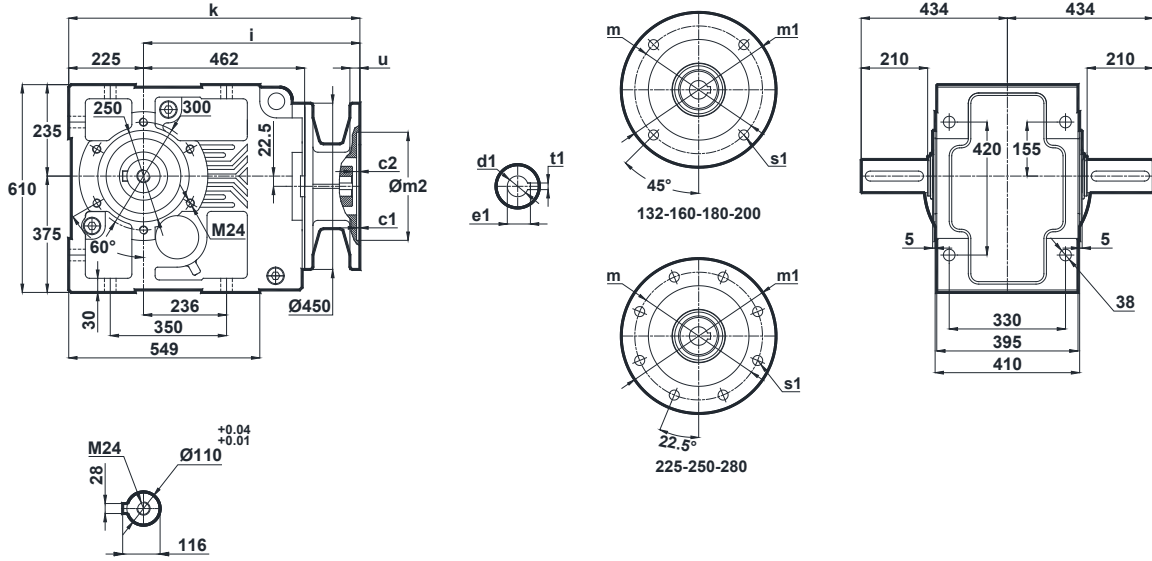

	c1	c2	s1	m	m1	m2	i	u	k	d1	t1	e1
132/B5	4.5	14	15	265	300	230	535	15	760	38	10	41.3
160/B5	5.5	10	19	300	350	250	680	20	905	42	12	45.3
180/B5	5.5	10	19	300	350	250	680	20	905	48	14	51.8
200/B5	5.5	10	19	350	400	300	680	22	905	55	16	59.3
225/B5	5.5	10	19	400	450	350	680	24	905	60	18	64.4
250/B5	5.5	10	19	500	550	450	680	24	905	65	18	69.4
280/B5	5.5	10	19	500	550	450	680	24	905	75	20	79.9

#### KN873.05

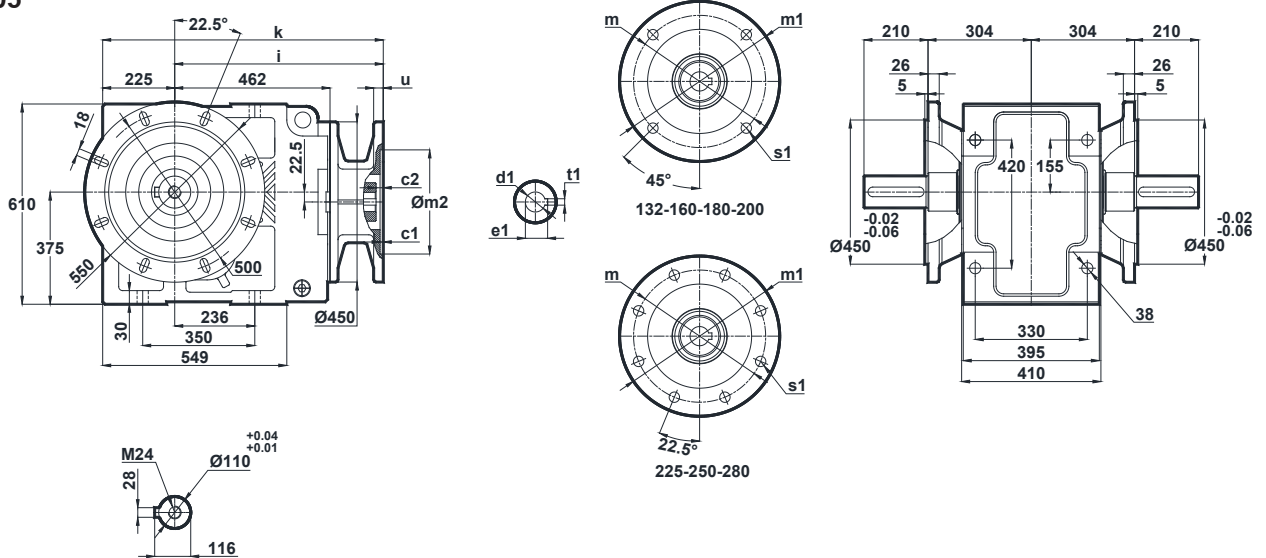

	c1	c2	s1	m	m1	m2	i	u	k	d1	t1	e1
132/B5	4.5	14	15	265	300	230	535	15	760	38	10	41.3
160/B5	5.5	10	19	300	350	250	680	20	905	42	12	45.3
180/B5	5.5	10	19	300	350	250	680	20	905	48	14	51.8
200/B5	5.5	10	19	350	400	300	680	22	905	55	16	59.3
225/B5	5.5	10	19	400	450	350	680	24	905	60	18	64.4
250/B5	5.5	10	19	500	550	450	680	24	905	65	18	69.4
280/B5	5.5	10	19	500	550	450	680	24	905	75	20	79.9

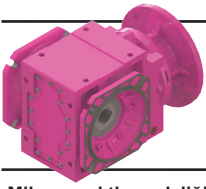

# Ölçü Sayfaları Dimension Pages Abmessungenseiten

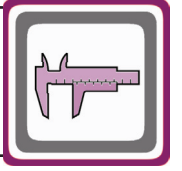

-Mil ucu çekirme deliği DIN 332 sayfa 2 / Tapped center hole to DIN 332, sheet 2 / Zentrierung mit Gewinde DIN 332, Blatt 2

KN873.08

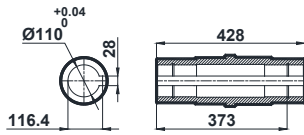
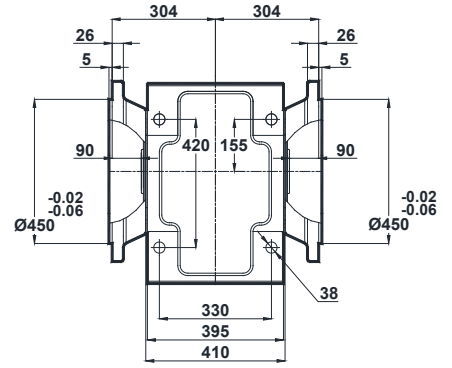
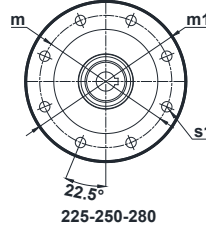
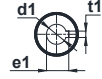
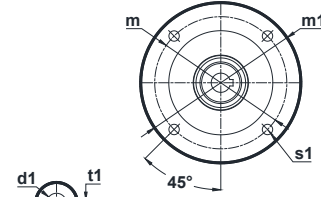
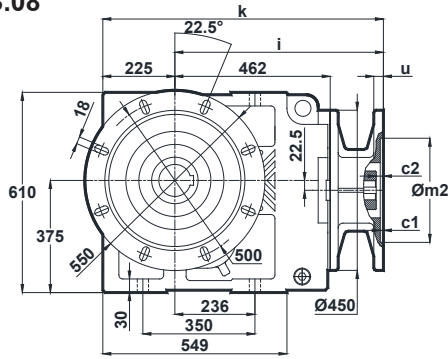

	c1	c2	s1	m	m1	m2	i	u	k	d1	t1	e1
132/B5	4.5	14	15	265	300	230	535	15	760	38	10	41.3
160/B5	5.5	10	19	300	350	250	680	20	905	42	12	45.3
180/B5	5.5	10	19	300	350	250	680	20	905	48	14	51.8
200/B5	5.5	10	19	350	400	300	680	22	905	55	16	59.3
225/B5	5.5	10	19	400	450	350	680	24	905	60	18	64.4
250/B5	5.5	10	19	500	550	450	680	24	905	65	18	69.4
280/B5	5.5	10	19	500	550	450	680	24	905	75	20	79.9

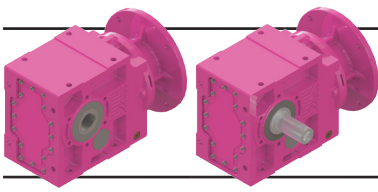

# Ölçü Sayfaları

## Dimension Pages

### Abmessungsseiten

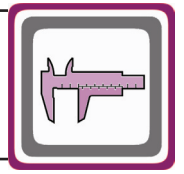

-Mil ucu çekirme deliği DIN 332 sayfa 2 / Tapped center hole to DIN 332, sheet 2 / Zentrierung mit Gewinde DIN 332, Blatt 2

#### KN874.00

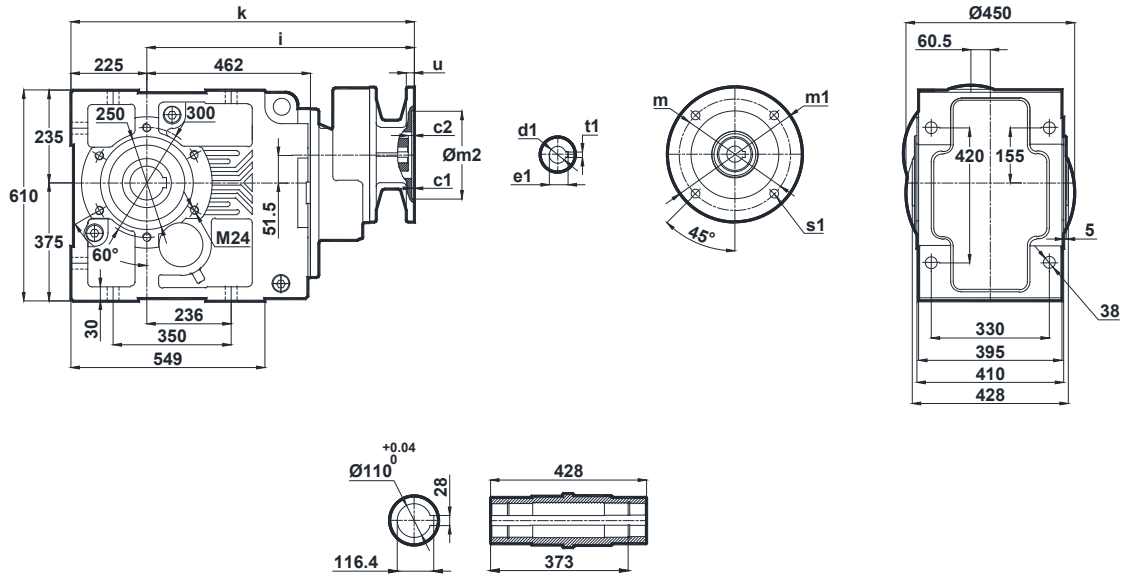

	c1	c2	s1	m	m1	m2	i	u	k	d1	t1	e1
100/B5	4.5	20	15	215	250	180	653	15	878	28	8	31.3
112/B5	4.5	20	15	215	250	180	653	15	878	28	8	31.3
132/B5 132/B14	4.5	9	15 11	265 165	300 200	230 130	674	15	899	38	10	41.3
160/B5	5.5	10	19	300	350	250	749	18	974	42	12	45.3
180/B5	5.5	10	19	300	350	250	749	18	974	48	14	51.8

#### KN874.01

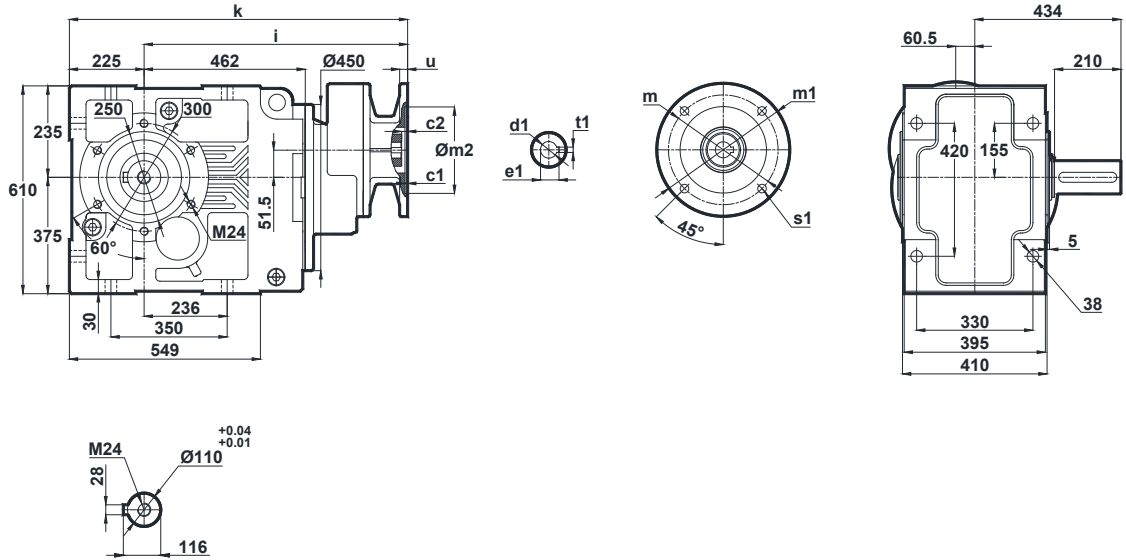

	c1	c2	s1	m	m1	m2	i	u	k	d1	t1	e1
100/B5	4.5	20	15	215	250	180	653	15	878	28	8	31.3
112/B5	4.5	20	15	215	250	180	653	15	878	28	8	31.3
132/B5 132/B14	4.5	9	15 11	265 165	300 200	230 130	674	15	899	38	10	41.3
160/B5	5.5	10	19	300	350	250	749	18	974	42	12	45.3
180/B5	5.5	10	19	300	350	250	749	18	974	48	14	51.8

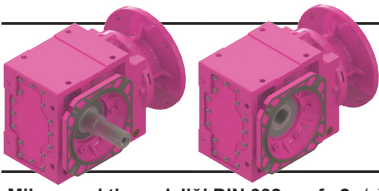

# Ölçü Sayfaları

## Dimension Pages

### Abmessungsseiten

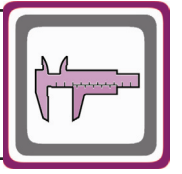

-Mil ucu çektirme deliği DIN 332 sayfa 2 / Tapped center hole to DIN 332, sheet 2 / Zentrierung mit Gewinde DIN 332, Blatt 2

#### KN874.02

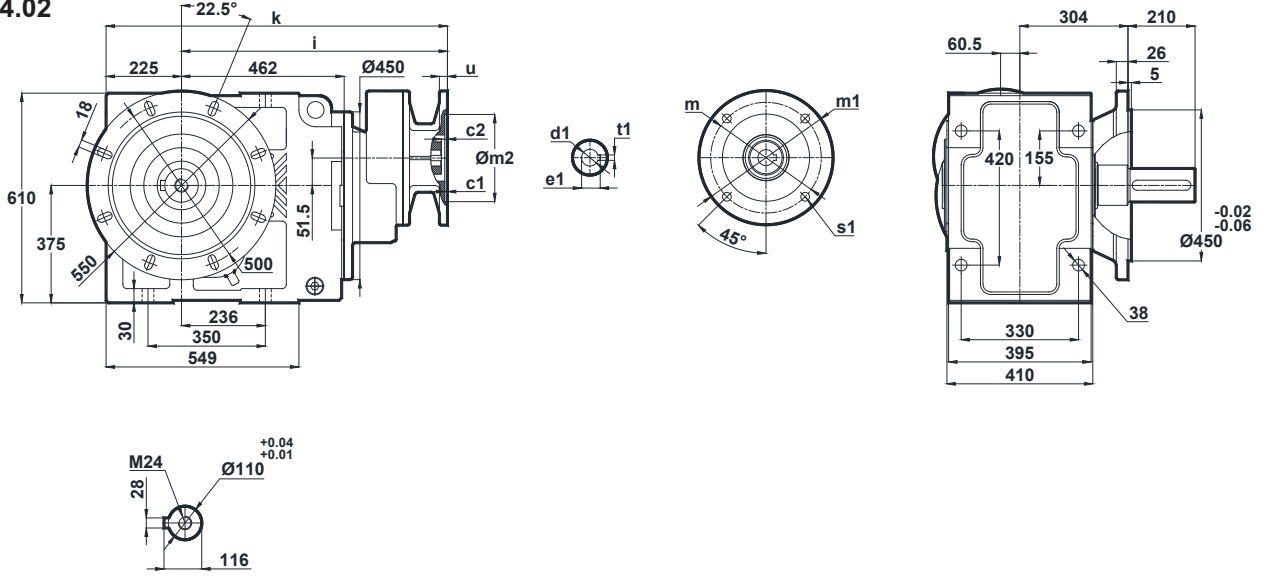

	c1	c2	s1	m	m1	m2	i	u	k	d1	t1	e1
100/B5	4.5	20	15	215	250	180	653	15	878	28	8	31.3
112/B5	4.5	20	15	215	250	180	653	15	878	28	8	31.3
132/B5 132/B14	4.5	9	15 11	265 165	300 200	230 130	674	15	899	38	10	41.3
160/B5	5.5	10	19	300	350	250	749	18	974	42	12	45.3
180/B5	5.5	10	19	300	350	250	749	18	974	48	14	51.8

#### KN874.03

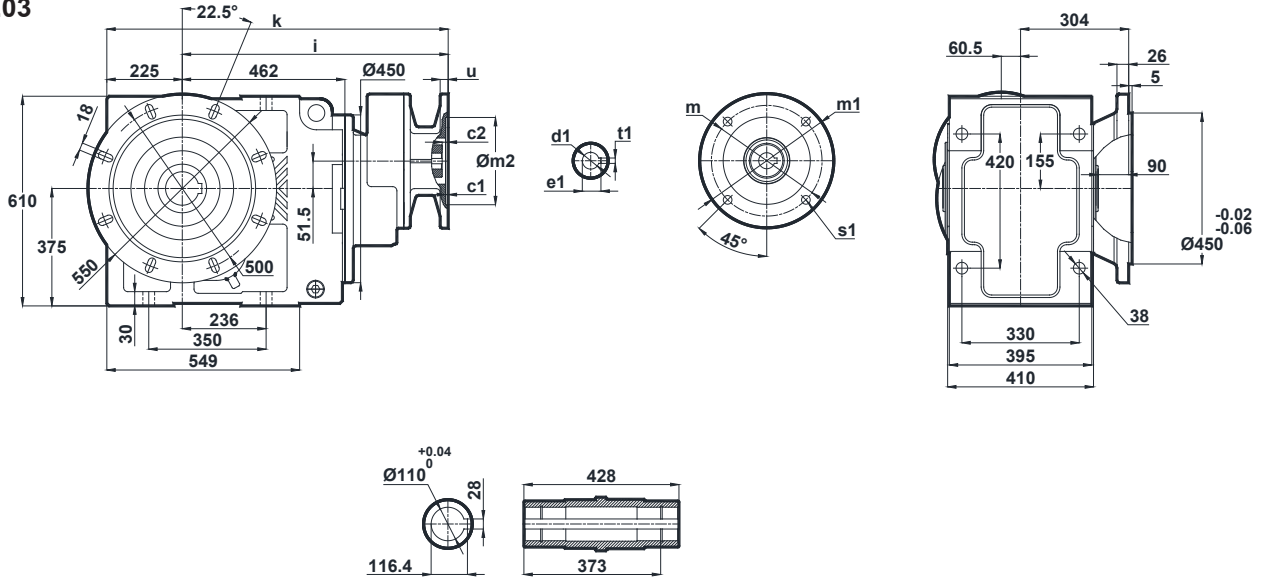

	c1	c2	s1	m	m1	m2	i	u	k	d1	t1	e1
100/B5	4.5	20	15	215	250	180	653	15	878	28	8	31.3
112/B5	4.5	20	15	215	250	180	653	15	878	28	8	31.3
132/B5 132/B14	4.5	9	15 11	265 165	300 200	230 130	674	15	899	38	10	41.3
160/B5	5.5	10	19	300	350	250	749	18	974	42	12	45.3
180/B5	5.5	10	19	300	350	250	749	18	974	48	14	51.8

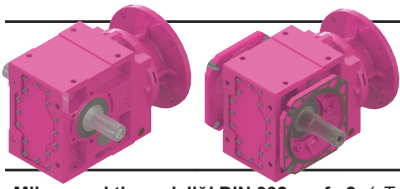

# Ölçü Sayfaları

## Dimension Pages

### Abmessungsseiten

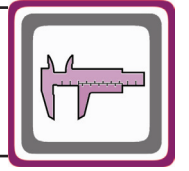

-Mil ucu çekirme deliği DIN 332 sayfa 2 / Tapped center hole to DIN 332, sheet 2 / Zentrierung mit Gewinde DIN 332, Blatt 2

#### KN874.04

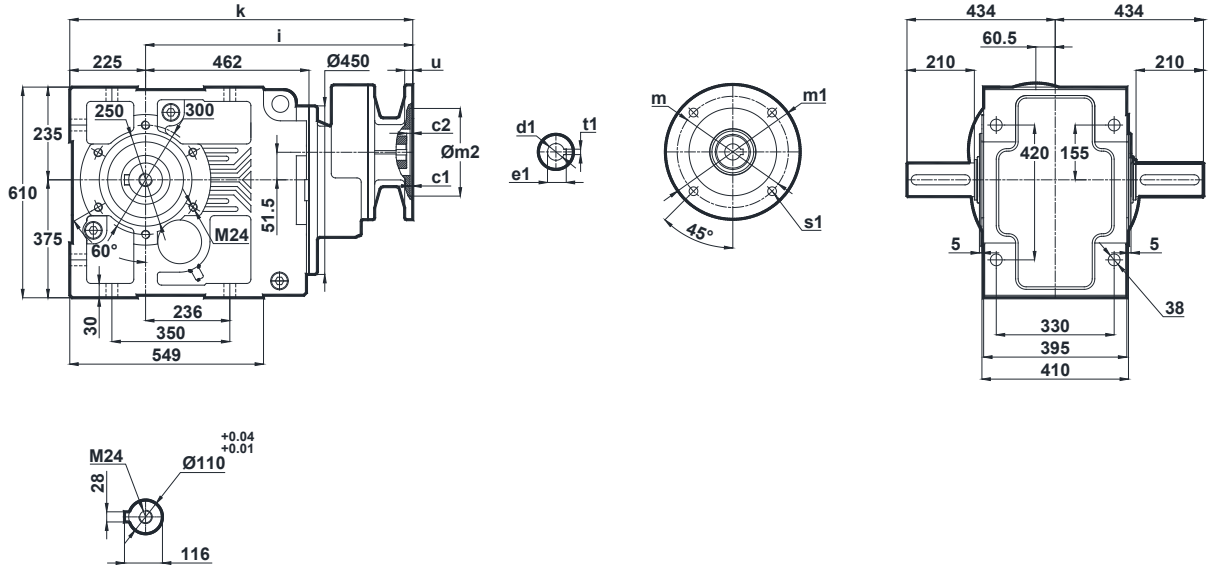

	c1	c2	s1	m	m1	m2	i	u	k	d1	t1	e1
100/B5	4.5	20	15	215	250	180	653	15	878	28	8	31.3
112/B5	4.5	20	15	215	250	180	653	15	878	28	8	31.3
132/B5 132/B14	4.5	9	15 11	265 165	300 200	230 130	674	15	899	38	10	41.3
160/B5	5.5	10	19	300	350	250	749	18	974	42	12	45.3
180/B5	5.5	10	19	300	350	250	749	18	974	48	14	51.8

#### KN874.05

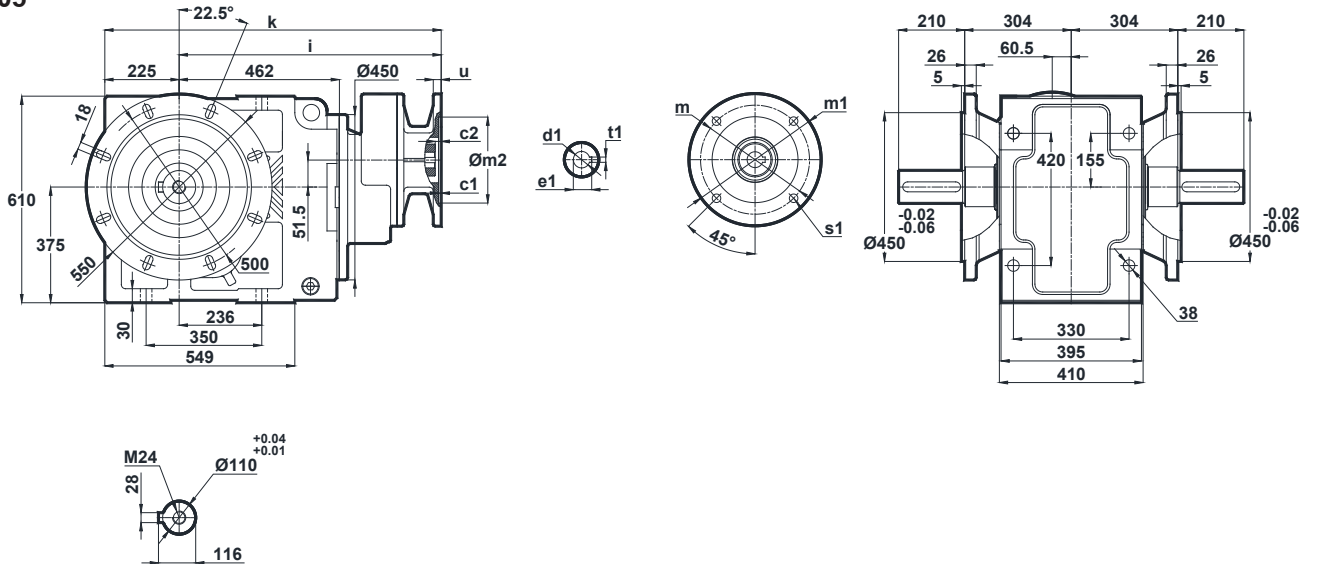

	c1	c2	s1	m	m1	m2	i	u	k	d1	t1	e1
100/B5	4.5	20	15	215	250	180	653	15	878	28	8	31.3
112/B5	4.5	20	15	215	250	180	653	15	878	28	8	31.3
132/B5 132/B14	4.5	9	15 11	265 165	300 200	230 130	674	15	899	38	10	41.3
160/B5	5.5	10	19	300	350	250	749	18	974	42	12	45.3
180/B5	5.5	10	19	300	350	250	749	18	974	48	14	51.8



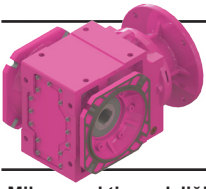

# Ölçü Sayfaları Dimension Pages Abmessungenseiten

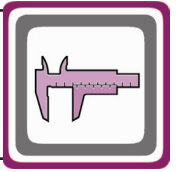

-Mil ucu çektirme deliği DIN 332 sayfa 2 / Tapped center hole to DIN 332, sheet 2 / Zentrierung mit Gewinde DIN 332, Blatt 2

KN874.08

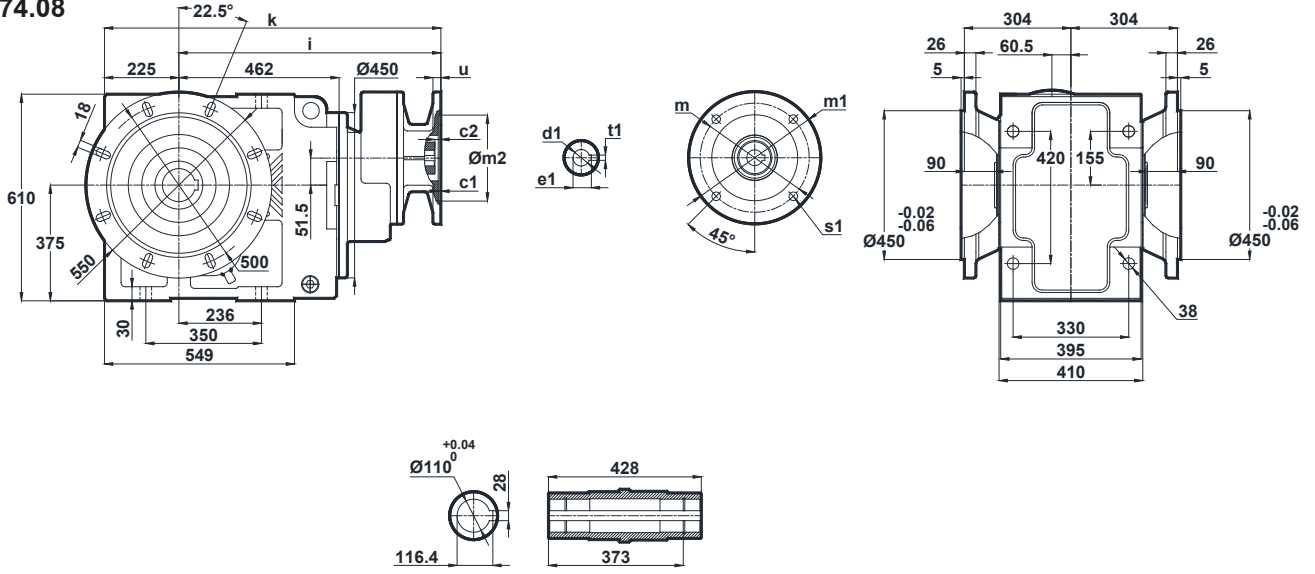

	c1	c2	s1	m	m1	m2	i	u	k	d1	t1	e1
<b>100/B5</b>	4.5	20	15	215	250	180	653	15	878	28	8	31.3
<b>112/B5</b>	4.5	20	15	215	250	180	653	15	878	28	8	31.3
<b>132/B5</b> <b>132/B14</b>	4.5	9	15 11	265 165	300 200	230 130	674	15	899	38	10	41.3
<b>160/B5</b>	5.5	10	19	300	350	250	749	18	974	42	12	45.3
<b>180/B5</b>	5.5	10	19	300	350	250	749	18	974	48	14	51.8

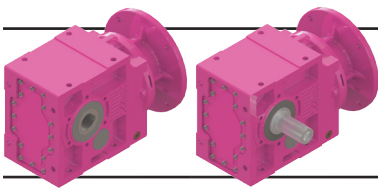

# Ölçü Sayfaları

## Dimension Pages

### Abmessungsseiten

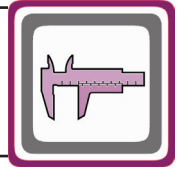

-Mil ucu çekirme deliği DIN 332 sayfa 2 / Tapped center hole to DIN 332, sheet 2 / Zentrierung mit Gewinde DIN 332, Blatt 2

KN875.00  
KN876.00

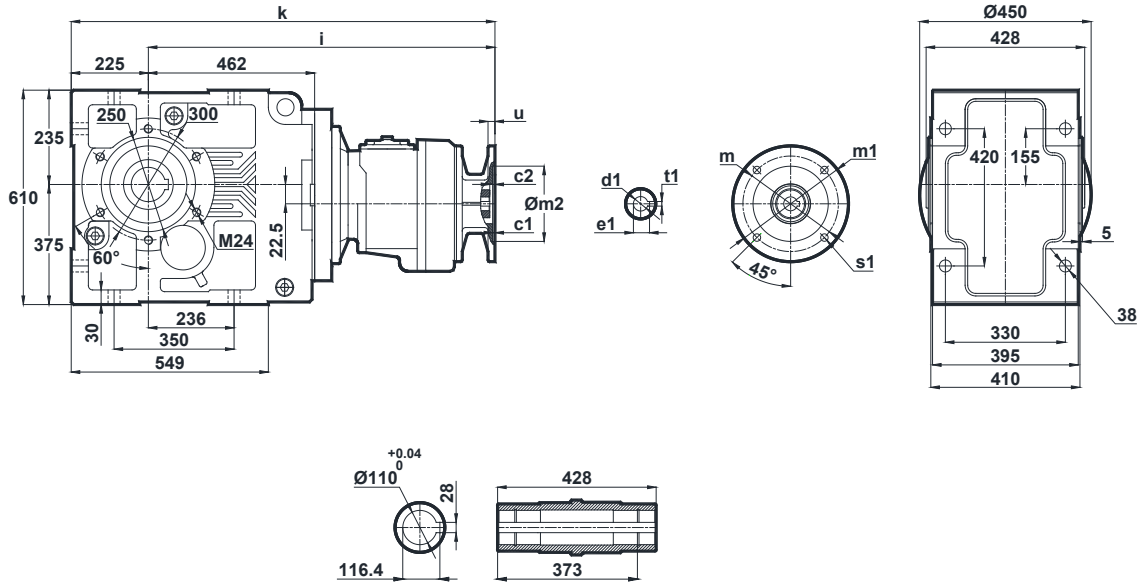

	c1	c2	s1	m	m1	m2	i	u	k	d1	t1	e1
71/B5	4	9	11	130	160	110	772	12	997	14	5	16.3
80/B5 80/B14	4	9	12 7	165 100	200 120	130 80	772	12	997	19	6 8	21.8
90/B5 90/B14	4	9	12 9	165 115	200 140	130 95	772	12	997	24	8	27.3 26.3
100/B5 100/B14	4.5 3.5	9	15 9	215 130	250 160	180 110	789	15	1014	28	8	31.3
112/B5 112/B14	4.5 3.5	9	15 9	215 130	250 160	180 110	789	15	1014	28	8	31.3

KN875.01  
KN876.01

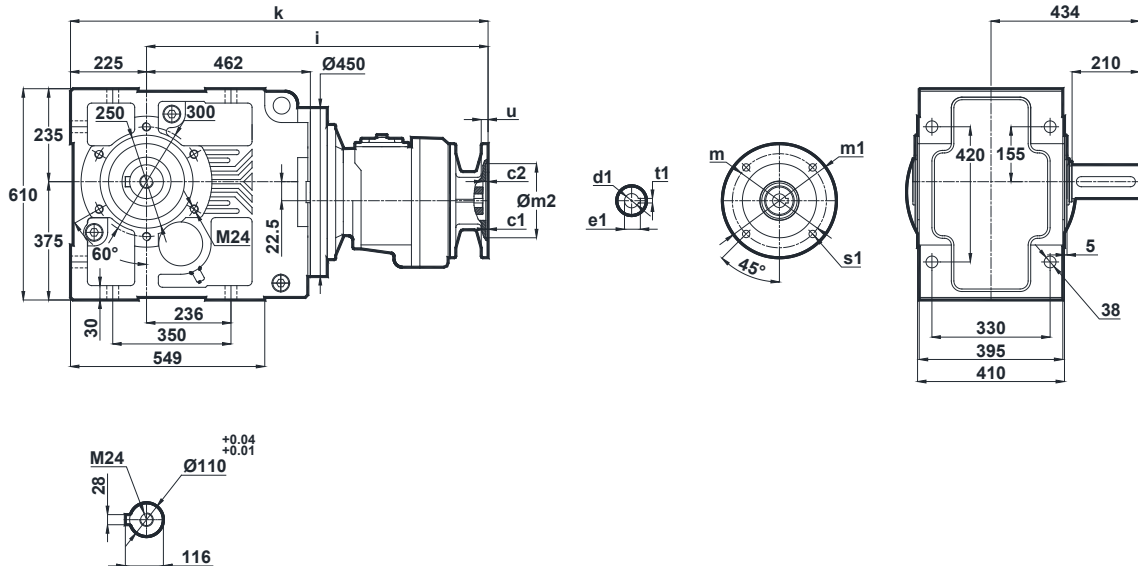

	c1	c2	s1	m	m1	m2	i	u	k	d1	t1	e1
71/B5	4	9	11	130	160	110	772	12	997	14	5	16.3
80/B5 80/B14	4	9	12 7	165 100	200 120	130 80	772	12	997	19	6 8	21.8
90/B5 90/B14	4	9	12 9	165 115	200 140	130 95	772	12	997	24	8	27.3 26.3
100/B5 100/B14	4.5 3.5	9	15 9	215 130	250 160	180 110	789	15	1014	28	8	31.3
112/B5 112/B14	4.5 3.5	9	15 9	215 130	250 160	180 110	789	15	1014	28	8	31.3

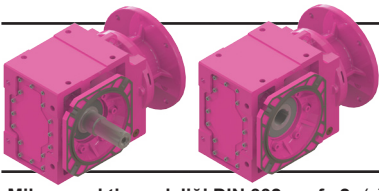

# Ölçü Sayfaları

## Dimension Pages

### Abmessungsseiten

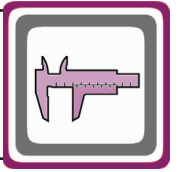

-Mil ucu çektirme deliği DIN 332 sayfa 2 / Tapped center hole to DIN 332, sheet 2 / Zentrierung mit Gewinde DIN 332, Blatt 2

KN875.02  
KN876.02

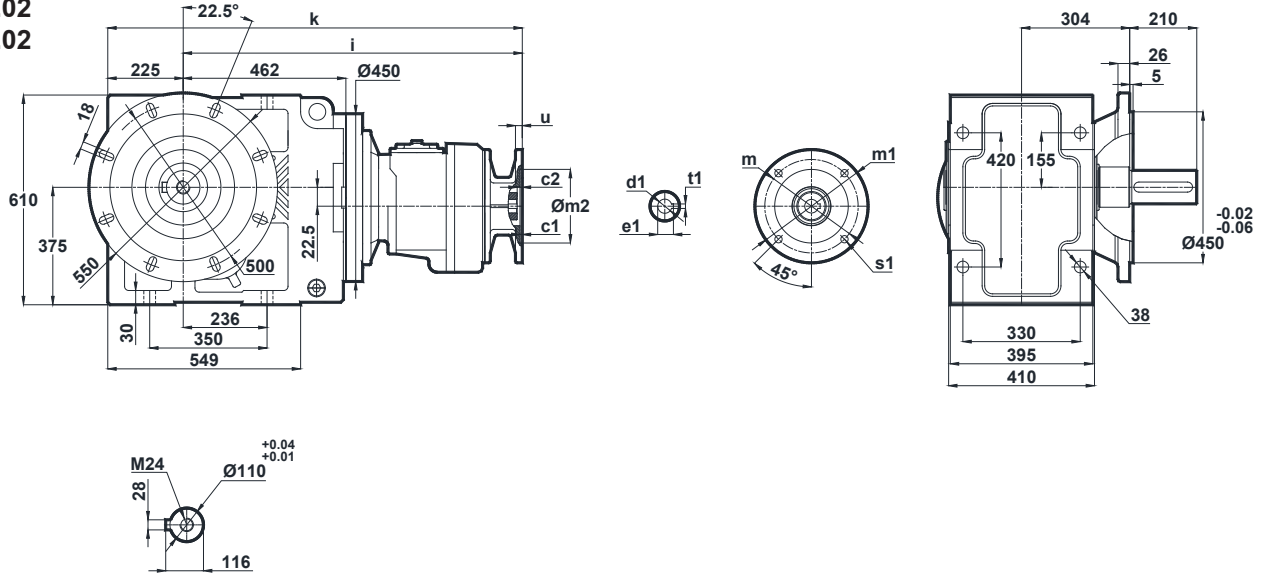

	c1	c2	s1	m	m1	m2	i	u	k	d1	t1	e1
71/B5	4	9	11	130	160	110	772	12	997	14	5	16.3
80/B5 80/B14	4	9	12 7	165 100	200 120	130 80	772	12	997	19	6 8	21.8
90/B5 90/B14	4	9	12 9	165 115	200 140	130 95	772	12	997	24	8	27.3 26.3
100/B5 100/B14	4.5 3.5	9	15 9	215 130	250 160	180 110	789	15	1014	28	8	31.3
112/B5 112/B14	4.5 3.5	9	15 9	215 130	250 160	180 110	789	15	1014	28	8	31.3

KN875.03  
KN876.03

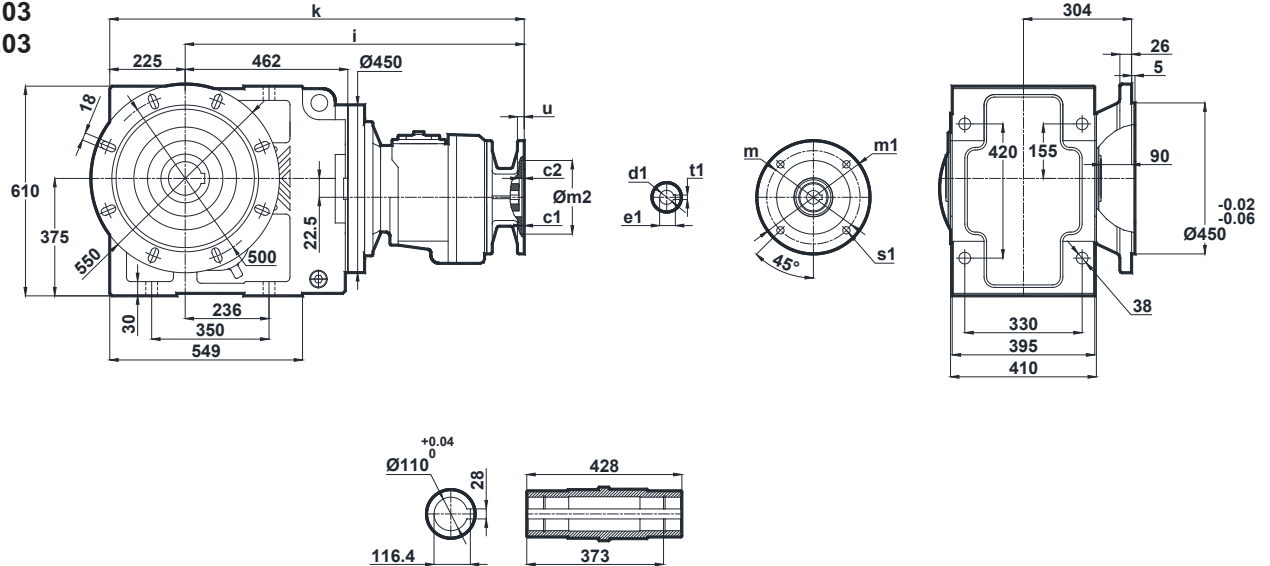

	c1	c2	s1	m	m1	m2	i	u	k	d1	t1	e1
71/B5	4	9	11	130	160	110	772	12	997	14	5	16.3
80/B5 80/B14	4	9	12 7	165 100	200 120	130 80	772	12	997	19	6 8	21.8
90/B5 90/B14	4	9	12 9	165 115	200 140	130 95	772	12	997	24	8	27.3 26.3
100/B5 100/B14	4.5 3.5	9	15 9	215 130	250 160	180 110	789	15	1014	28	8	31.3
112/B5 112/B14	4.5 3.5	9	15 9	215 130	250 160	180 110	789	15	1014	28	8	31.3

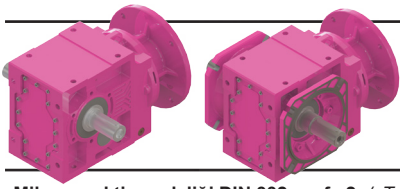

# Ölçü Sayfaları

## Dimension Pages

### Abmessungsseiten

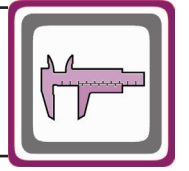

-Mil ucu çektirme deliği DIN 332 sayfa 2 / Tapped center hole to DIN 332, sheet 2 / Zentrierung mit Gewinde DIN 332, Blatt 2

KN875.04  
KN876.04

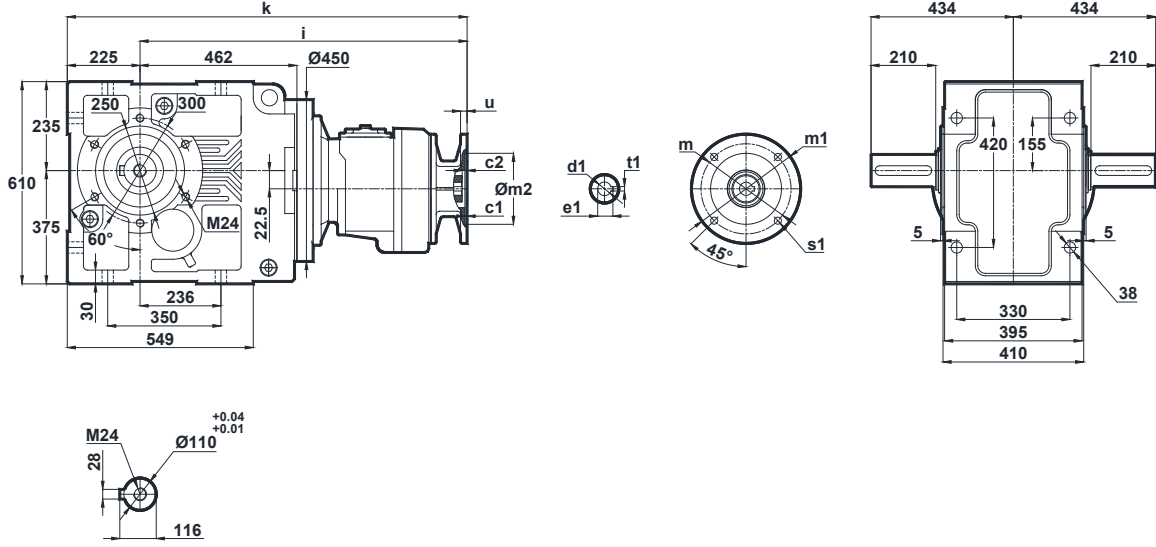

	c1	c2	s1	m	m1	m2	i	u	k	d1	t1	e1
71/B5	4	9	11	130	160	110	772	12	997	14	5	16.3
80/B5 80/B14	4	9	12 7	165 100	200 120	130 80	772	12	997	19	6 8	21.8
90/B5 90/B14	4	9	12 9	165 115	200 140	130 95	772	12	997	24	8	27.3 26.3
100/B5 100/B14	4.5 3.5	9	15 9	215 130	250 160	180 110	789	15	1014	28	8	31.3
112/B5 112/B14	4.5 3.5	9	15 9	215 130	250 160	180 110	789	15	1014	28	8	31.3

KN875.05  
KN876.05

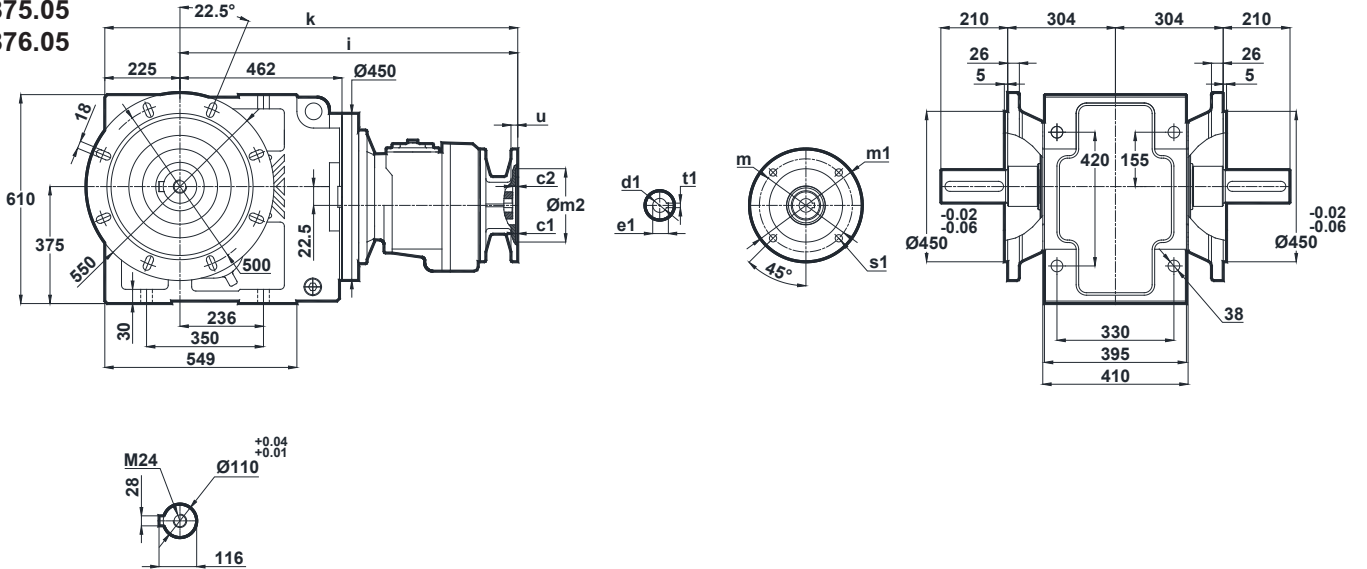

	c1	c2	s1	m	m1	m2	i	u	k	d1	t1	e1
71/B5	4	9	11	130	160	110	772	12	997	14	5	16.3
80/B5 80/B14	4	9	12 7	165 100	200 120	130 80	772	12	997	19	6 8	21.8
90/B5 90/B14	4	9	12 9	165 115	200 140	130 95	772	12	997	24	8	27.3 26.3
100/B5 100/B14	4.5 3.5	9	15 9	215 130	250 160	180 110	789	15	1014	28	8	31.3
112/B5 112/B14	4.5 3.5	9	15 9	215 130	250 160	180 110	789	15	1014	28	8	31.3

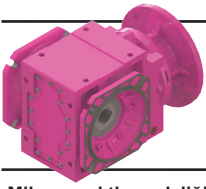

# Ölçü Sayfaları

## Dimension Pages

### Abmessungsseiten

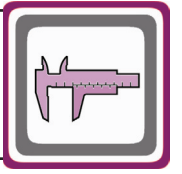

-Mil ucu çektirme deliği DIN 332 sayfa 2 / Tapped center hole to DIN 332, sheet 2 / Zentrierung mit Gewinde DIN 332, Blatt 2

KN875.08  
KN876.08

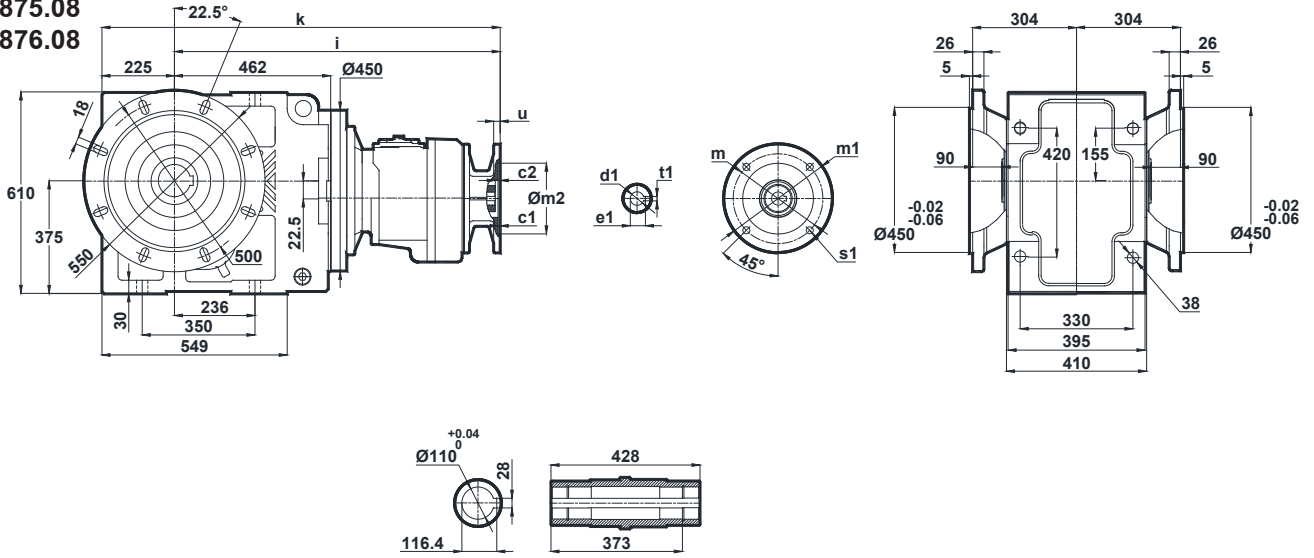

	c1	c2	s1	m	m1	m2	i	u	k	d1	t1	e1
71/B5	4	9	11	130	160	110	772	12	997	14	5	16.3
80/B5 80/B14	4	9	12 7	165 100	200 120	130 80	772	12	997	19	6 8	21.8
90/B5 90/B14	4	9	12 9	165 115	200 140	130 95	772	12	997	24	8	27.3 26.3
100/B5 100/B14	4.5 3.5	9	15 9	215 130	250 160	180 110	789	15	1014	28	8	31.3
112/B5 112/B14	4.5 3.5	9	15 9	215 130	250 160	180 110	789	15	1014	28	8	31.3

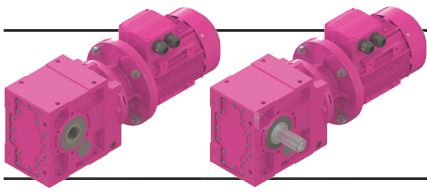

# Ölçü Sayfaları

## Dimension Pages

## Abmessungsseiten

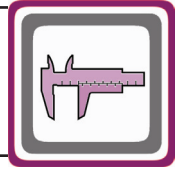

-Mil ucu çekirme deliği DIN 332 sayfa 2 / Tapped center hole to DIN 332, sheet 2 / Zentrierung mit Gewinde DIN 332, Blatt 2

KV002.00  
KV003.00

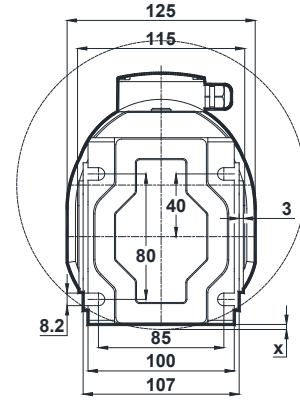
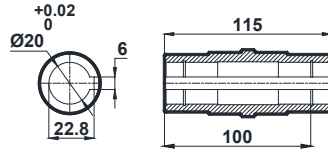
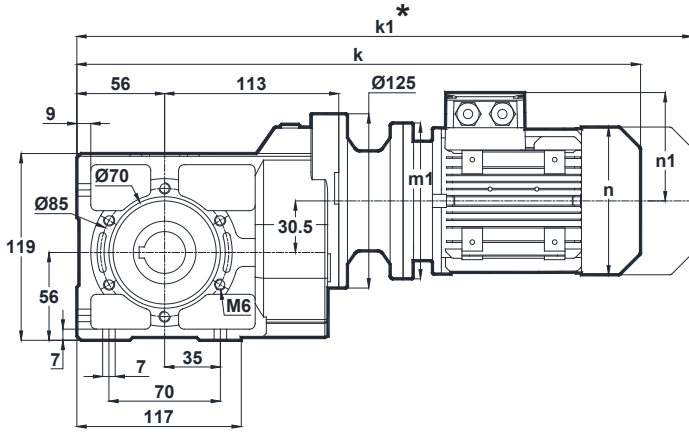

x: Motor ayak bağlantı yüzeyinin altında ise  
x: If Motor is lower than foot mounting plane  
x: Wenn der Motor unter der Fußmontageebene ist

	63/B5 63/B14	71/B5 71/B14	80/B5 80/B14	90S/B5 90S/B14	90L/B5 90L/B14
k	375	425	463	504	504
k1	436	516	556	608.5	608.5
n / n1	121 / 97	137 / 112	155 / 121	176 / 132	176 / 132
m1 (B5)	140	160	200	200	200
m1 (B14)	90	105	120	140	140
x	-	-	13,5	13,5	13,5

Klemens Pozisyonları  
Terminal Box Positions  
Klemmenkasten Positionen

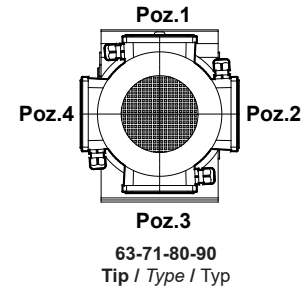

KV002.01  
KV003.01

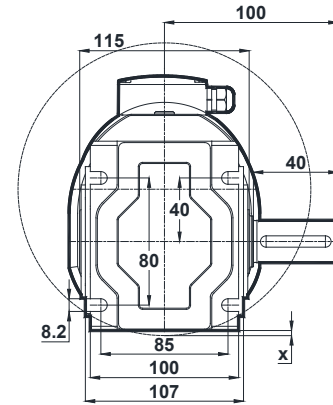
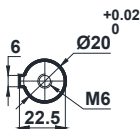
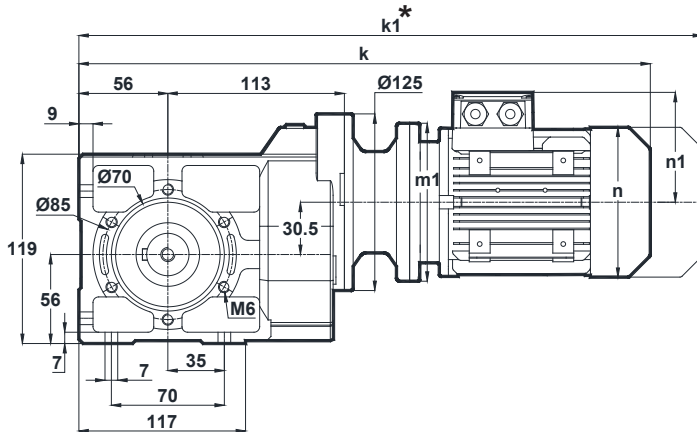

x: Motor ayak bağlantı yüzeyinin altında ise  
x: If Motor is lower than foot mounting plane  
x: Wenn der Motor unter der Fußmontageebene ist

	63/B5 63/B14	71/B5 71/B14	80/B5 80/B14	90S/B5 90S/B14	90L/B5 90L/B14
k	375	425	463	504	504
k1	436	516	556	608.5	608.5
n / n1	121 / 97	137 / 112	155 / 121	176 / 132	176 / 132
m1 (B5)	140	160	200	200	200
m1 (B14)	90	105	120	140	140
x	-	-	13,5	13,5	13,5

\* " k1 " Ölçüsü frenli redüktörlere aittir.  
Dimension " k1 " is for motors with brake.  
Maße " k1 " ist für Bremsmotoren.

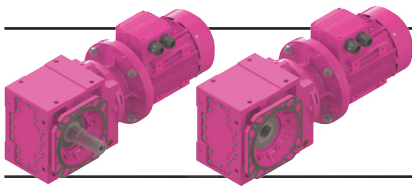

# Ölçü Sayfaları

## Dimension Pages

### Abmessungsseiten

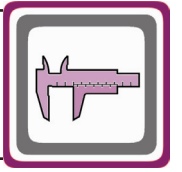

-Mil ucu çekirme deliği DIN 332 sayfa 2 / Tapped center hole to DIN 332, sheet 2 / Zentrierung mit Gewinde DIN 332, Blatt 2

KV002.02  
KV003.02

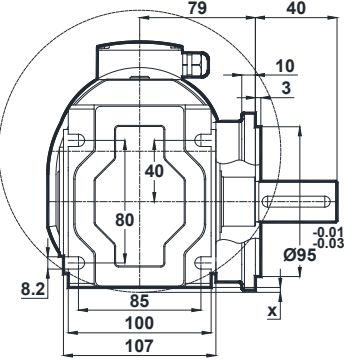
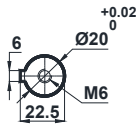
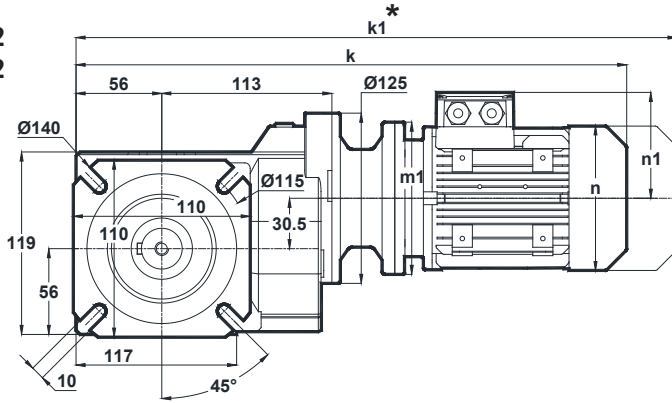

x: Motor Ayak bağlantı yüzeyinin altında ise  
x: If Motor is lower than foot mounting plane  
x: Wenn der Motor unter der Fußmontageebene ist

Klemens Pozisyonları  
Terminal Box Positions  
Klemmenkasten Positionen

	63/B5 63/B14	71/B5 71/B14	80/B5 80/B14	90S/B5 90S/B14	90L/B5 90L/B14
k	375	425	463	504	504
k1	436	516	556	608.5	608.5
n / n1	121 / 97	137 / 112	155 / 121	176 / 132	176 / 132
m1 (B5)	140	160	200	200	200
m1 (B14)	90	105	120	140	140
x	-	-	13,5	13,5	13,5

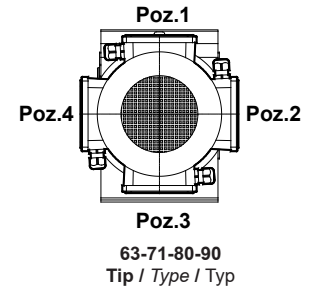

KV002.03  
KV003.03

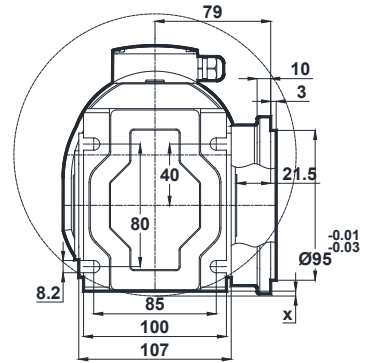
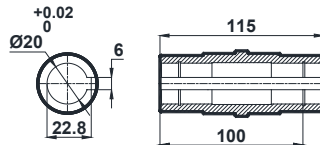
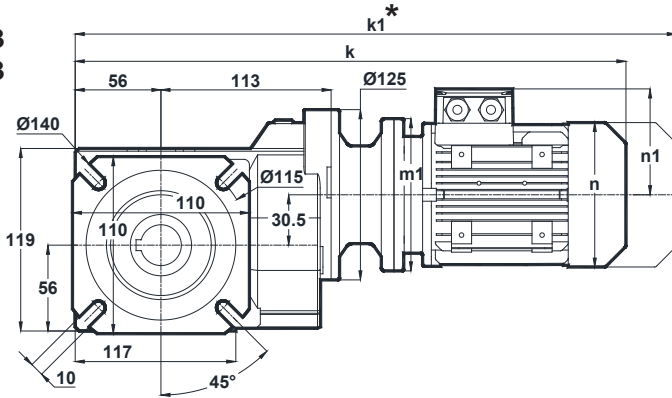

x: Motor Ayak bağlantı yüzeyinin altında ise  
x: If Motor is lower than foot mounting plane  
x: Wenn der Motor unter der Fußmontageebene ist

	63/B5 63/B14	71/B5 71/B14	80/B5 80/B14	90S/B5 90S/B14	90L/B5 90L/B14
k	375	425	463	504	504
k1	436	516	556	608.5	608.5
n / n1	121 / 97	137 / 112	155 / 121	176 / 132	176 / 132
m1 (B5)	140	160	200	200	200
m1 (B14)	90	105	120	140	140
x	-	-	13,5	13,5	13,5

\* " k1 " Ölçüsü frenli redüktörlere aittir.  
Dimension " k1 " is for motors with brake.  
Maße " k1 " ist für Bremsenmotoren.

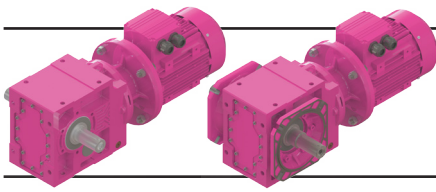

# Ölçü Sayfaları

## Dimension Pages

### Abmessungsseiten

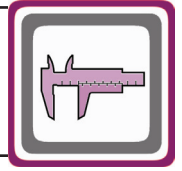

-Mil ucu çektirme deliği DIN 332 sayfa 2 / Tapped center hole to DIN 332, sheet 2 / Zentrierung mit Gewinde DIN 332, Blatt 2

KV002.04  
KV003.04

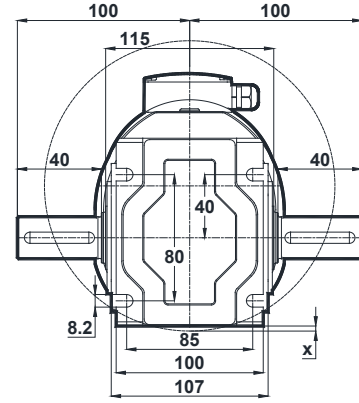
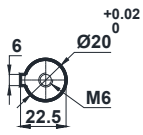
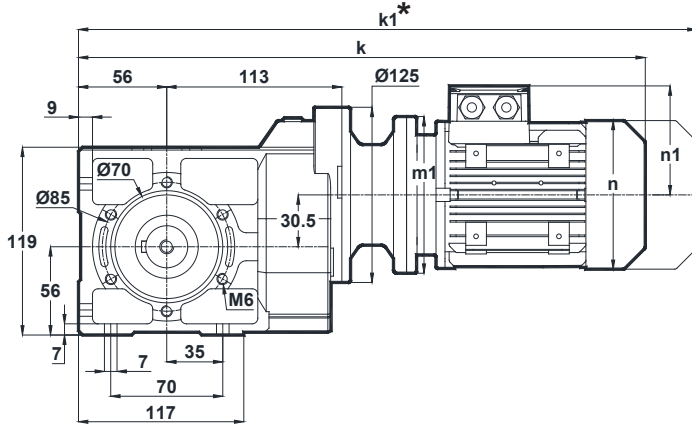

x: Motor Ayak bağlantı yüzeyinin altında ise  
x: If Motor is lower than foot mounting plane  
x: Wenn der Motor unter der Fußmontageebene ist

	63/B5 63/B14	71/B5 71/B14	80/B5 80/B14	90S/B5 90S/B14	90L/B5 90L/B14
k	375	425	463	504	504
k1	436	516	556	608.5	608.5
n / n1	121 / 97	137 / 112	155 / 121	176 / 132	176 / 132
m1 (B5)	140	160	200	200	200
m1 (B14)	90	105	120	140	140
x	-	-	13,5	13,5	13,5

Klemens Pozisyonları  
Terminal Box Positions  
Klemmenkasten Positionen

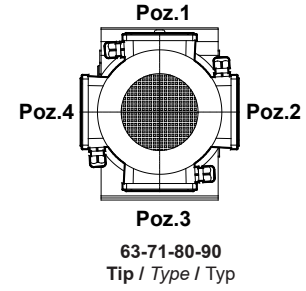

KV002.05  
KV003.05

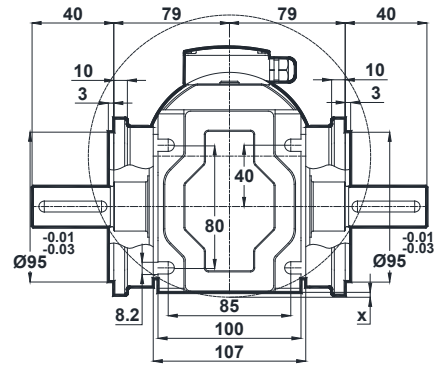
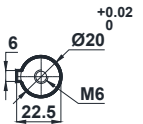
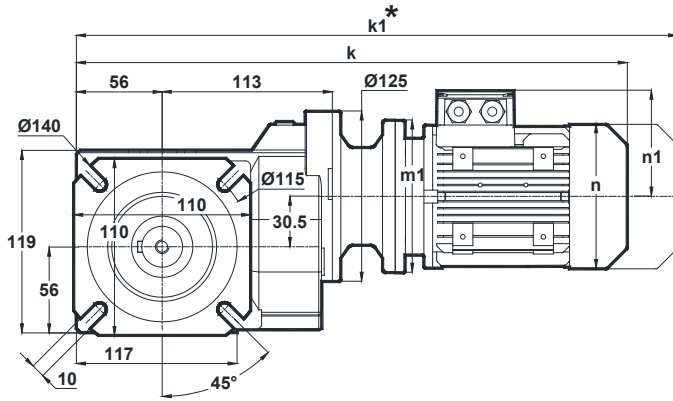

x: Motor Ayak bağlantı yüzeyinin altında ise  
x: If Motor is lower than foot mounting plane  
x: Wenn der Motor unter der Fußmontageebene ist

	63/B5 63/B14	71/B5 71/B14	80/B5 80/B14	90S/B5 90S/B14	90L/B5 90L/B14
k	375	425	463	504	504
k1	436	516	556	608.5	608.5
n / n1	121 / 97	137 / 112	155 / 121	176 / 132	176 / 132
m1 (B5)	140	160	200	200	200
m1 (B14)	90	105	120	140	140
x	-	-	13,5	13,5	13,5

\* "k1" Ölçüsü frenli redüktörlere aittir.  
Dimension "k1" is for motors with brake.  
Maße "k1" ist für Bremsmotoren.



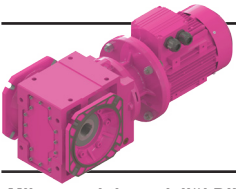

# Ölçü Sayfaları Dimension Pages Abmessungsseiten



-Mil ucu çektirme deliği DIN 332 sayfa 2 / Tapped center hole to DIN 332, sheet 2 / Zentrierung mit Gewinde DIN 332, Blatt 2

KV002.08  
KV003.08

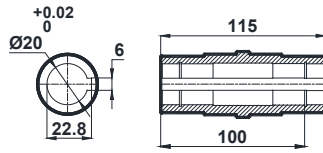
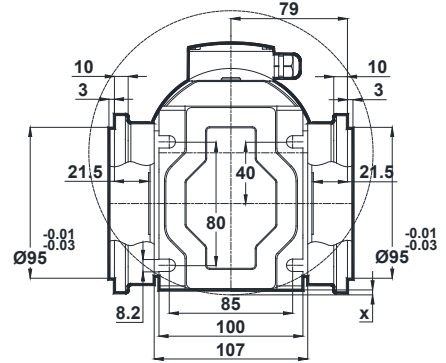
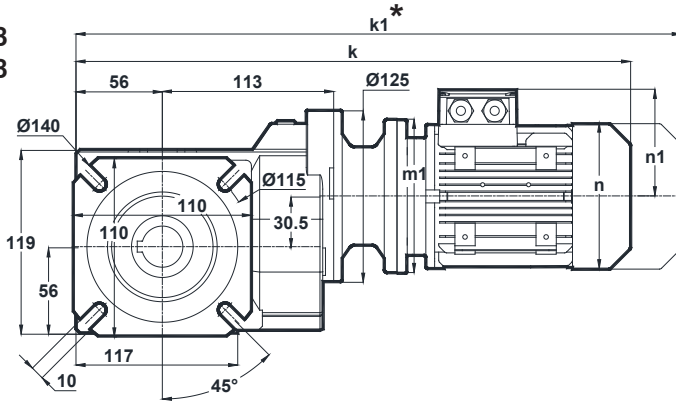

x: Motor Ayak bağlantı yüzeyinin altında ise  
x: If Motor is lower than foot mounting plane  
x: Wenn der Motor unter der Fußmontageebene ist

	63/B5 63/B14	71/B5 71/B14	80/B5 80/B14	90S/B5 90S/B14	90L/B5 90L/B14
k	375	425	463	504	504
k1	436	516	556	608.5	608.5
n / n1	121 / 97	137 / 112	155 / 121	176 / 132	176 / 132
m1 (B5)	140	160	200	200	200
m1 (B14)	90	105	120	140	140
x	-	-	13,5	13,5	13,5

Klemens Pozisyonları  
Terminal Box Positions  
Klemmenkasten Positionen

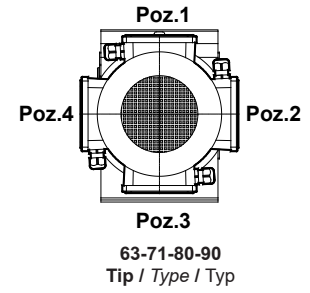

\* " k1 " Ölçüsü frenli redüktörlere aittir.  
Dimension " k1 " is for motors with brake.  
Maße " k1 " ist für Bremsenmotoren.

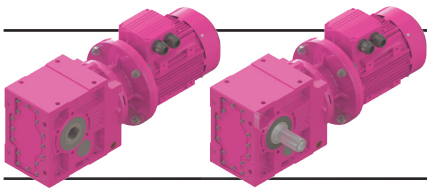

# Ölçü Sayfaları

## Dimension Pages

## Abmessungsseiten

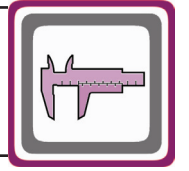

-Mil ucu çektirme deliği DIN 332 sayfa 2 / Tapped center hole to DIN 332, sheet 2 / Zentrierung mit Gewinde DIN 332, Blatt 2

KV102.00  
KV103.00

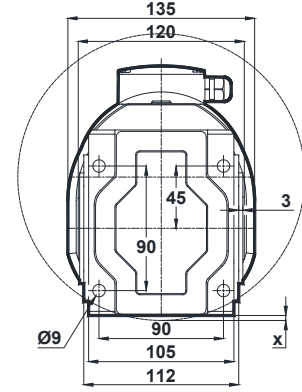
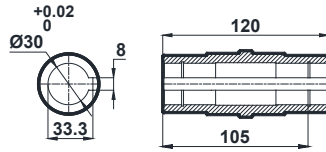
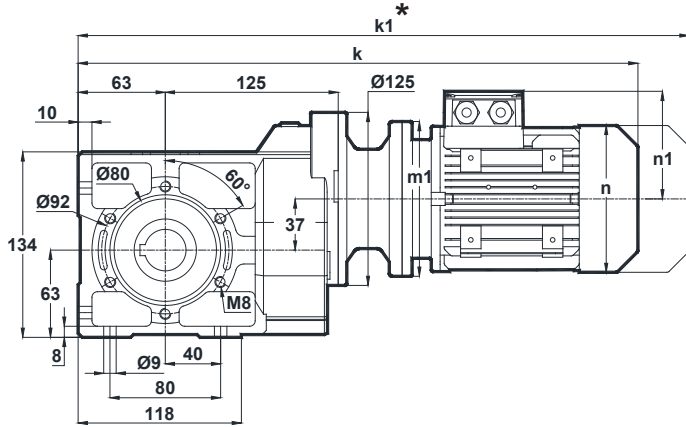

x: Motor Ayak bağlantı yüzeyinin altında ise  
x: If Motor is lower than foot mounting plane  
x: Wenn der Motor unter der Fußmontageebene ist

Klemens Pozisyonları  
Terminal Box Positions  
Klemmenkasten Positionen

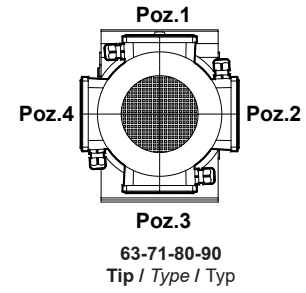

	63/B5 63/B14	71/B5 71/B14	80/B5 80/B14	90S/B5 90S/B14	90L/B5 90L/B14
k	394	444	482	523	523
k1	455	535	575	627.5	627.5
n / n1	121 / 97	137 / 112	155 / 121	176 / 132	176 / 132
m1 (B5)	140	160	200	200	200
m1 (B14)	90	105	120	140	140
x	-	-	-	-	-

KV102.01  
KV103.01

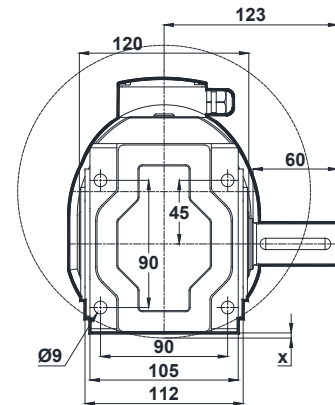
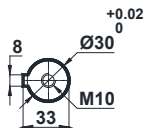
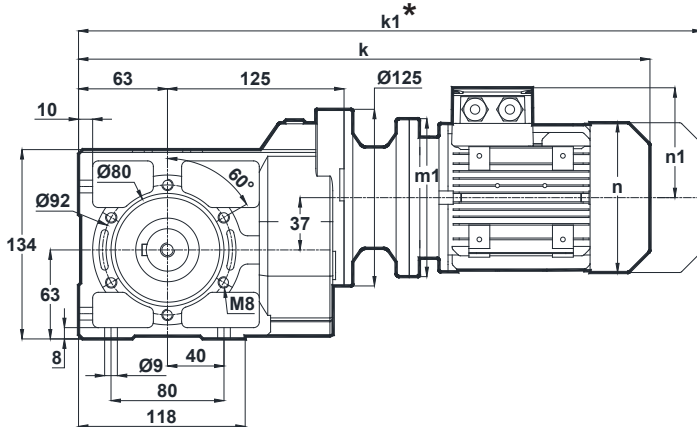

x: Motor Ayak bağlantı yüzeyinin altında ise  
x: If Motor is lower than foot mounting plane  
x: Wenn der Motor unter der Fußmontageebene ist

	63/B5 63/B14	71/B5 71/B14	80/B5 80/B14	90S/B5 90S/B14	90L/B5 90L/B14
k	394	444	482	523	523
k1	455	535	575	627.5	627.5
n / n1	121 / 97	137 / 112	155 / 121	176 / 132	176 / 132
m1 (B5)	140	160	200	200	200
m1 (B14)	90	105	120	140	140
x	-	-	-	-	-

\* " k1 " Ölçüsü frenli redüktörlere aittir.  
Dimension " k1 " is for motors with brake.  
Maße " k1 " ist für Bremsmotoren.

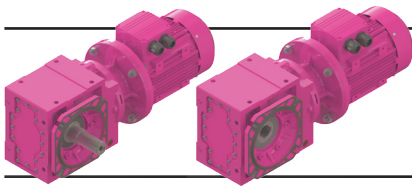

# Ölçü Sayfaları

## Dimension Pages

### Abmessungsseiten



-Mil ucu çekirme deliği DIN 332 sayfa 2 / Tapped center hole to DIN 332, sheet 2 / Zentrierung mit Gewinde DIN 332, Blatt 2

KV102.02  
KV103.02

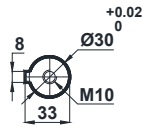
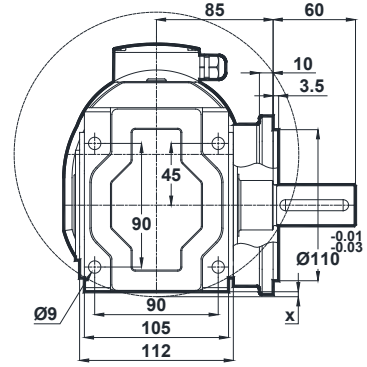
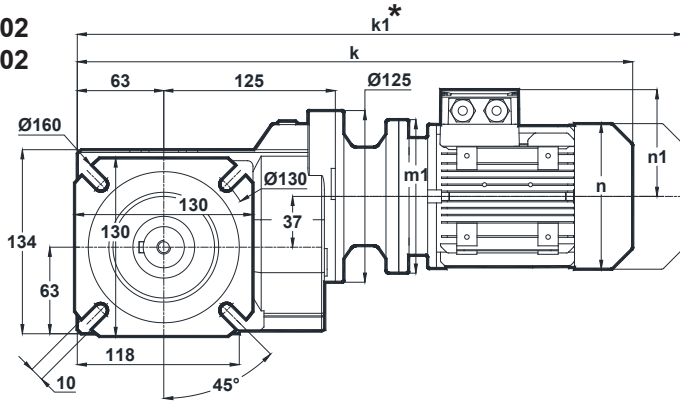

x: Motor Ayak bağlantı yüzeyinin altında ise  
x: If Motor is lower than foot mounting plane  
x: Wenn der Motor unter der Fußmontageebene ist

Klemens Pozisyonları  
Terminal Box Positions  
Klemmenkasten Positionen

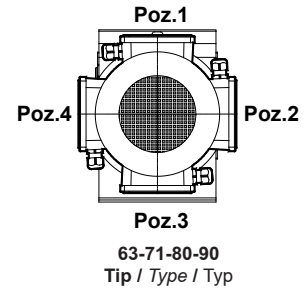

	63/B5 63/B14	71/B5 71/B14	80/B5 80/B14	90S/B5 90S/B14	90L/B5 90L/B14
k	394	444	482	523	523
k1	455	535	575	627.5	627.5
n / n1	121 / 97	137 / 112	155 / 121	176 / 132	176 / 132
m1 (B5)	140	160	200	200	200
m1 (B14)	90	105	120	140	140
x	-	-	-	-	-

KV102.03  
KV103.03

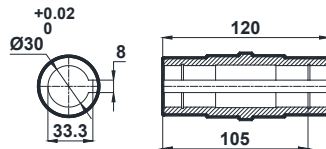
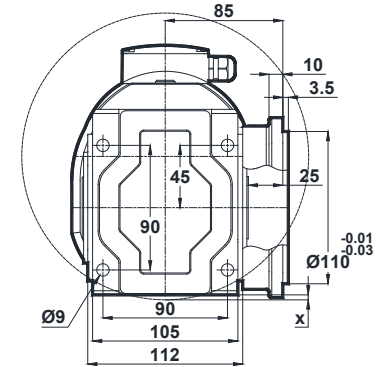
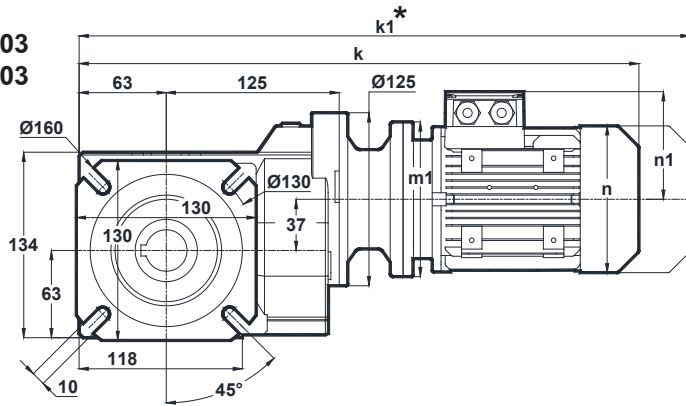

x: Motor Ayak bağlantı yüzeyinin altında ise  
x: If Motor is lower than foot mounting plane  
x: Wenn der Motor unter der Fußmontageebene ist

	63/B5 63/B14	71/B5 71/B14	80/B5 80/B14	90S/B5 90S/B14	90L/B5 90L/B14
k	394	444	482	523	523
k1	455	535	575	627.5	627.5
n / n1	121 / 97	137 / 112	155 / 121	176 / 132	176 / 132
m1 (B5)	140	160	200	200	200
m1 (B14)	90	105	120	140	140
x	-	-	-	-	-

\* " k1 " Ölçüsü frenli redüktörlere aittir.  
Dimension " k1 " is for motors with brake.  
Maße " k1 " ist für Bremsenmotoren.

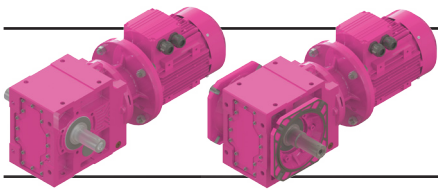

# Ölçü Sayfaları Dimension Pages Abmessungsseiten

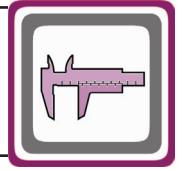

-Mil ucu çektirme deliği DIN 332 sayfa 2 / Tapped center hole to DIN 332, sheet 2 / Zentrierung mit Gewinde DIN 332, Blatt 2

KV102.04  
KV103.04

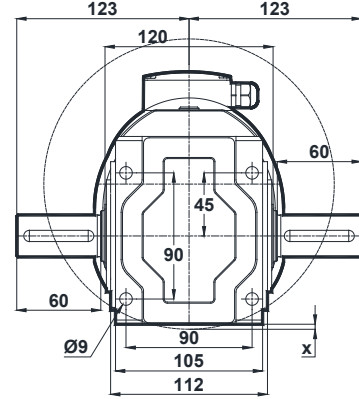
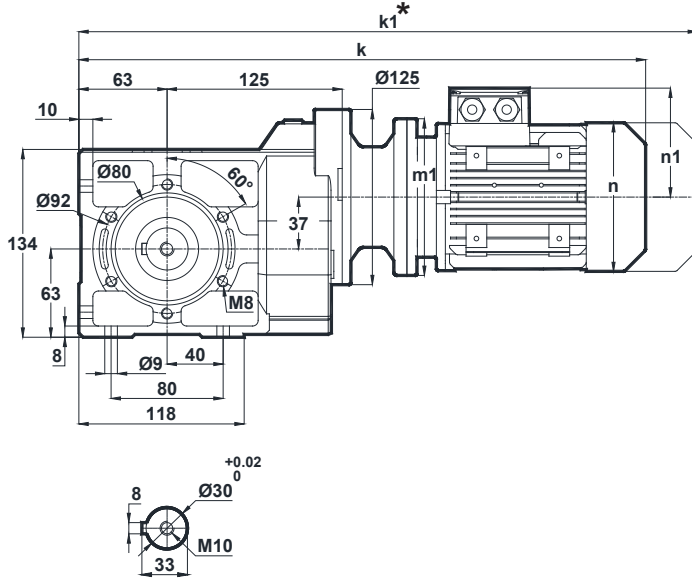

x: Motor Ayak bağlantı yüzeyinin altında ise  
x: If Motor is lower than foot mounting plane  
x: Wenn der Motor unter der Fußmontageebene ist

Klemens Pozisyonları  
Terminal Box Positions  
Klemmenkasten Positionen

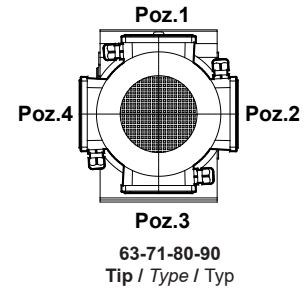

	63/B5 63/B14	71/B5 71/B14	80/B5 80/B14	90S/B5 90S/B14	90L/B5 90L/B14
k	394	444	482	523	523
k1	455	535	575	627.5	627.5
n / n1	121 / 97	137 / 112	155 / 121	176 / 132	176 / 132
m1 (B5)	140	160	200	200	200
m1 (B14)	90	105	120	140	140
x	-	-	-	-	-

KV102.05  
KV103.05

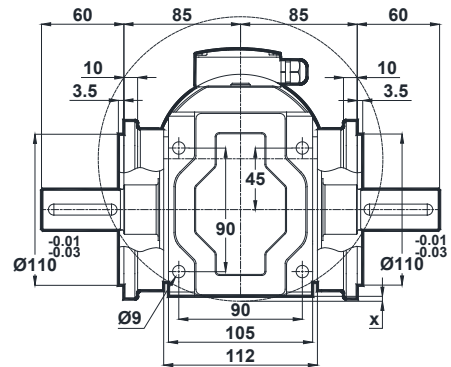
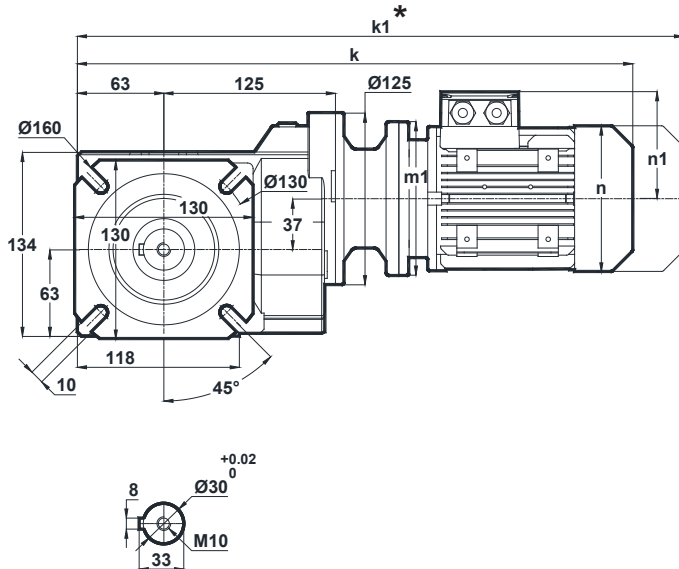

x: Motor Ayak bağlantı yüzeyinin altında ise  
x: If Motor is lower than foot mounting plane  
x: Wenn der Motor unter der Fußmontageebene ist

	63/B5 63/B14	71/B5 71/B14	80/B5 80/B14	90S/B5 90S/B14	90L/B5 90L/B14
k	394	444	482	523	523
k1	455	535	575	627.5	627.5
n / n1	121 / 97	137 / 112	155 / 121	176 / 132	176 / 132
m1 (B5)	140	160	200	200	200
m1 (B14)	90	105	120	140	140
x	-	-	-	-	-

\* " k1 " Ölçüsü frenli redüktörlere aittir.  
Dimension " k1 " is for motors with brake.  
Maße " k1 " ist für Bremsmotoren.

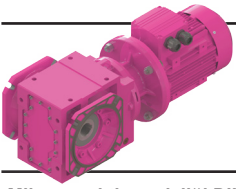

# Ölçü Sayfaları Dimension Pages Abmessungsseiten

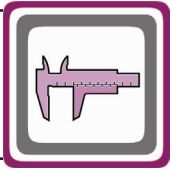

-Mil ucu çekirme deliği DIN 332 sayfa 2 / Tapped center hole to DIN 332, sheet 2 / Zentrierung mit Gewinde DIN 332, Blatt 2

KV102.08  
KV103.08

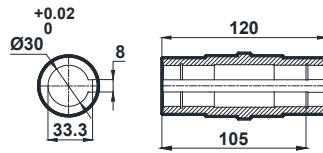
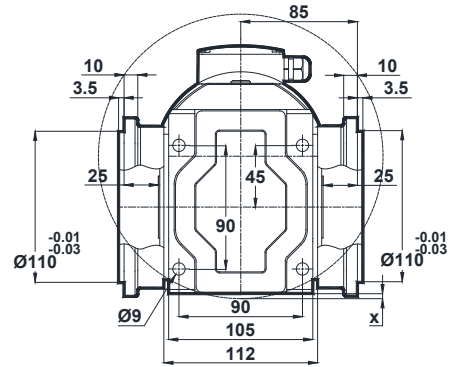
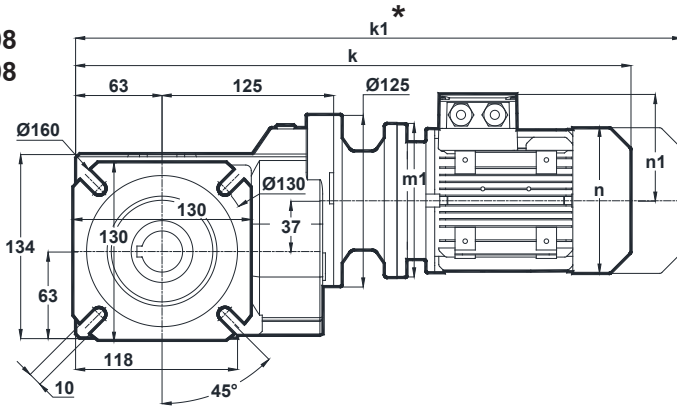

x: Motor Ayak bağlantı yüzeyinin altında ise  
x: If Motor is lower than foot mounting plane  
x: Wenn der Motor unter der Fußmontageebene ist

Klemens Pozisyonları  
Terminal Box Positions  
Klemmenkasten Positionen

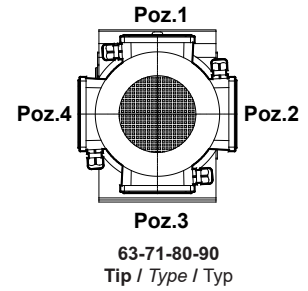

	63/B5 63/B14	71/B5 71/B14	80/B5 80/B14	90S/B5 90S/B14	90L/B5 90L/B14
k	394	444	482	523	523
k1	455	535	575	627.5	627.5
n / n1	121 / 97	137 / 112	155 / 121	176 / 132	176 / 132
m1 (B5)	140	160	200	200	200
m1 (B14)	90	105	120	140	140
x	-	-	-	-	-

\* " k1 " Ölçüsü frenli redüktörlere aittir.  
Dimension " k1 " is for motors with brake.  
Maße " k1 " ist für Bremsenmotoren.

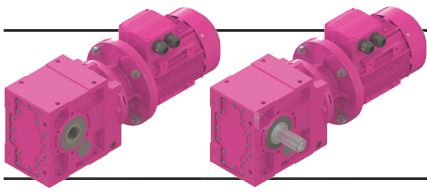

# Ölçü Sayfaları

## Dimension Pages

## Abmessungsseiten

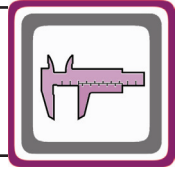

-Mil ucu çektirme deliği DIN 332 sayfa 2 / Tapped center hole to DIN 332, sheet 2 / Zentrierung mit Gewinde DIN 332, Blatt 2

KV202.00  
KV203.00

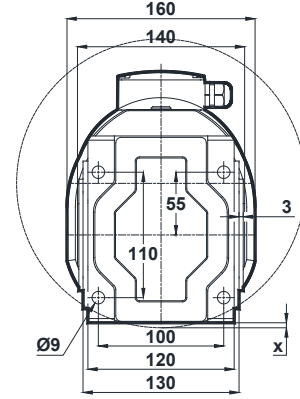
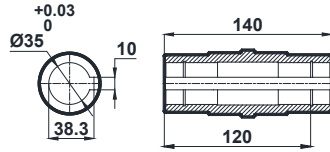
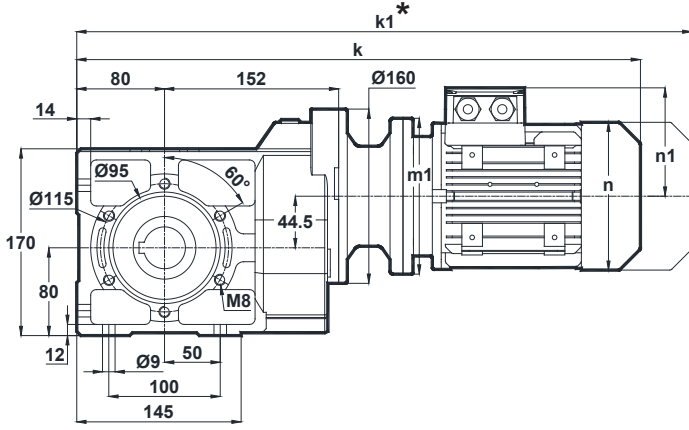

x: Motor ayak bağlantı yüzeyinin altında ise  
x: If Motor is lower than foot mounting plane  
x: Wenn der Motor unter der Fußmontageebene ist

Klemens Pozisyonları  
Terminal Box Positions  
Klemmenkasten Positionen

	63/B5	71/B5 71/B14	80/B580/ B14	90S/B5 90S/B14	90L/B5 90L/B14	100L/B5 100L/B14	112M/B5 112M/B14
k	469	488	540	581	581	609	630
k1	530	579	633	685.5	685.5	728.5	734.5
n / n1	121 / 97	137 / 112	155 / 121	176 / 132	176 / 132	193 / 147	215 / 158
m1 (B5)	140	160	200	200	200	250	250
m1 (B14)	-	105	120	140	140	160	160
x	-	-	-	-	-	0,5	0,5

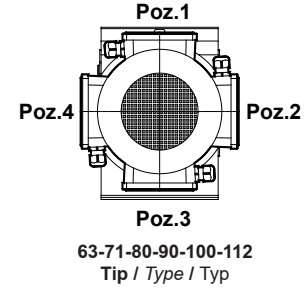

KV202.01  
KV203.01

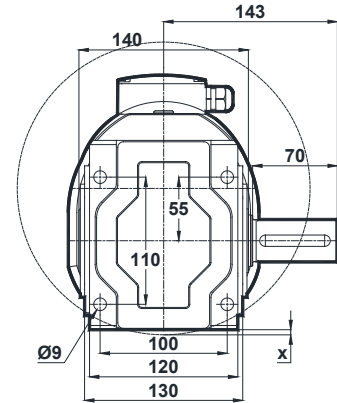
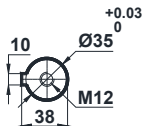
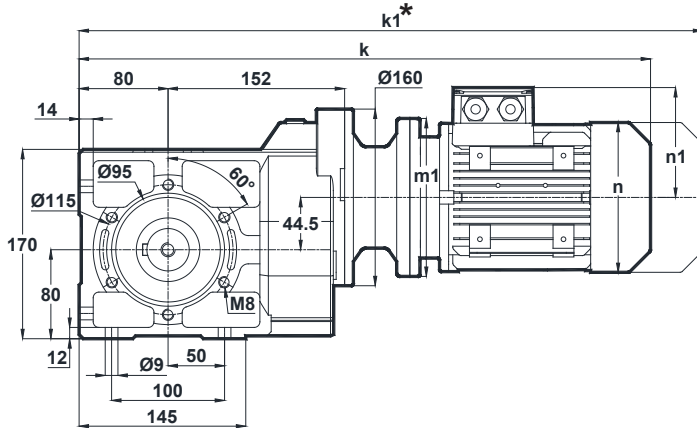

x: Motor ayak bağlantı yüzeyinin altında ise  
x: If Motor is lower than foot mounting plane  
x: Wenn der Motor unter der Fußmontageebene ist

	63/B5	71/B5 71/B14	80/B580/ B14	90S/B5 90S/B14	90L/B5 90L/B14	100L/B5 100L/B14	112M/B5 112M/B14
k	469	488	540	581	581	609	630
k1	530	579	633	685.5	685.5	728.5	734.5
n / n1	121 / 97	137 / 112	155 / 121	176 / 132	176 / 132	193 / 147	215 / 158
m1 (B5)	140	160	200	200	200	250	250
m1 (B14)	-	105	120	140	140	160	160
x	-	-	-	-	-	0,5	0,5

\* " k1 " Ölçüsü frenli redüktörlere aittir.  
Dimension " k1 " is for motors with brake.  
Maße " k1 " ist für Bremsmotoren.

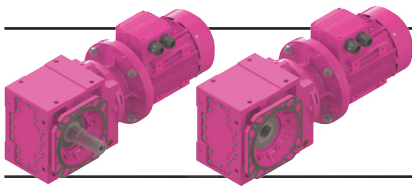

# Ölçü Sayfaları

## Dimension Pages

### Abmessungsseiten

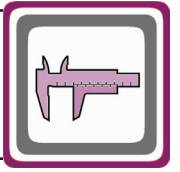

-Mil ucu çektirme deliği DIN 332 sayfa 2 / Tapped center hole to DIN 332, sheet 2 / Zentrierung mit Gewinde DIN 332, Blatt 2

KV202.02  
KV203.02

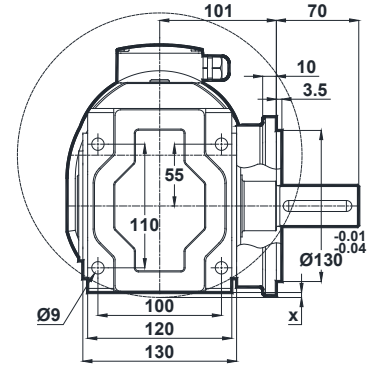
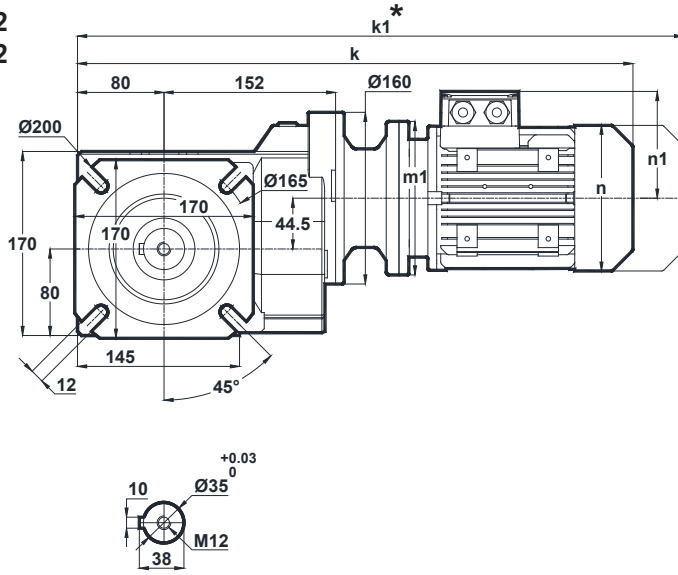

x: Motor Ayak bağlantı yüzeyinin altında ise  
x: If Motor is lower than foot mounting plane  
x: Wenn der Motor unter der Fußmontageebene ist

Klemens Pozisyonları  
Terminal Box Positions  
Klemmenkasten Positionen

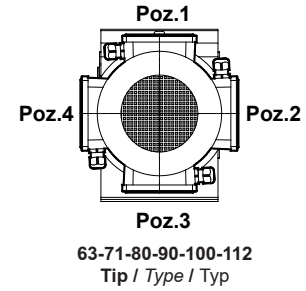

	63/B5	71/B5 71/B14	80/B580/ B14	90S/B5 90S/B14	90L/B5 90L/B14	100L/B5 100L/B14	112M/B5 112M/B14
k	469	488	540	581	581	609	630
k1	530	579	633	685.5	685.5	728.5	734.5
n / n1	121 / 97	137 / 112	155 / 121	176 / 132	176 / 132	193 / 147	215 / 158
m1 (B5)	140	160	200	200	200	250	250
m1 (B14)	-	105	120	140	140	160	160
x	-	-	-	-	-	0,5	0,5

KV202.03  
KV203.03

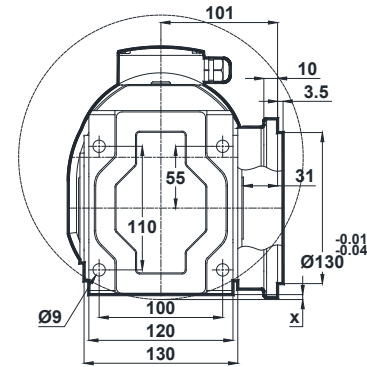
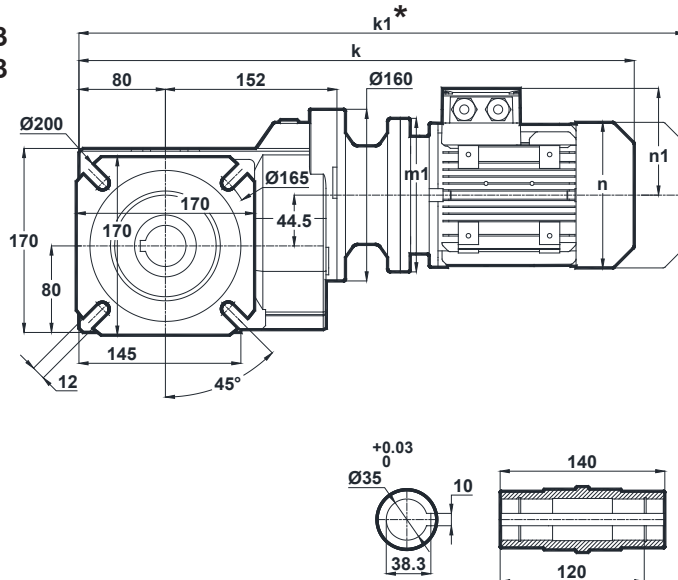

x: Motor Ayak bağlantı yüzeyinin altında ise  
x: If Motor is lower than foot mounting plane  
x: Wenn der Motor unter der Fußmontageebene ist

	63/B5	71/B5 71/B14	80/B580/ B14	90S/B5 90S/B14	90L/B5 90L/B14	100L/B5 100L/B14	112M/B5 112M/B14
k	469	488	540	581	581	609	630
k1	530	579	633	685.5	685.5	728.5	734.5
n / n1	121 / 97	137 / 112	155 / 121	176 / 132	176 / 132	193 / 147	215 / 158
m1 (B5)	140	160	200	200	200	250	250
m1 (B14)	-	105	120	140	140	160	160
x	-	-	-	-	-	0,5	0,5

\* " k1 " Ölçüsü frenli redüktörlere aittir.  
Dimension " k1 " is for motors with brake.  
Maße " k1 " ist für Bremsenmotoren.

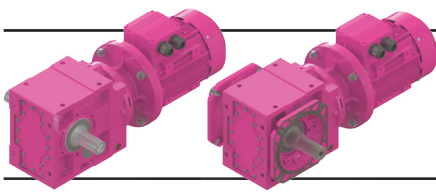

# Ölçü Sayfaları

## Dimension Pages

### Abmessungsseiten

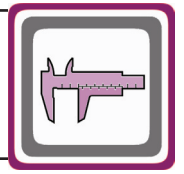

-Mil ucu çekirme deliği DIN 332 sayfa 2 / Tapped center hole to DIN 332, sheet 2 / Zentrierung mit Gewinde DIN 332, Blatt 2

KV202.04  
KV203.04

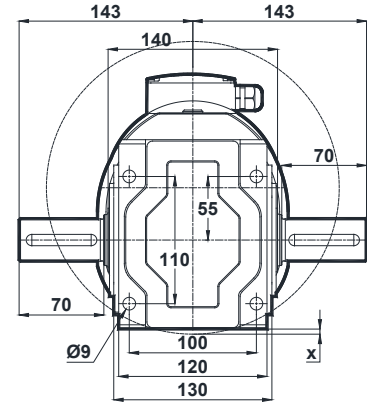
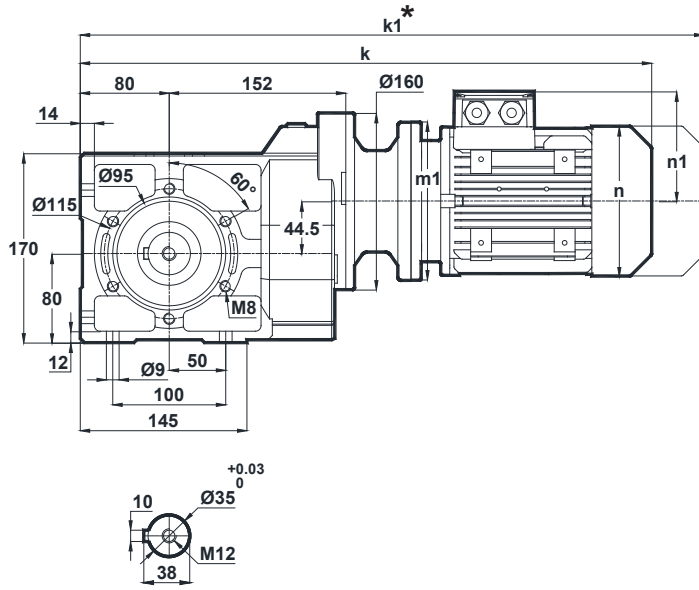

x: Motor Ayak bağlantı yüzeyinin altında ise  
x: If Motor is lower than foot mounting plane  
x: Wenn der Motor unter der Fußmontageebene ist

Klemens Pozisyonları  
Terminal Box Positions  
Klemmenkasten Positionen

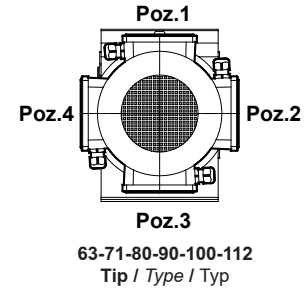

	63/B5	71/B5 71/B14	80/B580/ B14	90S/B5 90S/B14	90L/B5 90L/B14	100L/B5 100L/B14	112M/B5 112M/B14
k	469	488	540	581	581	609	630
k1	530	579	633	685.5	685.5	728.5	734.5
n / n1	121 / 97	137 / 112	155 / 121	176 / 132	176 / 132	193 / 147	215 / 158
m1 (B5)	140	160	200	200	200	250	250
m1 (B14)	-	105	120	140	140	160	160
x	-	-	-	-	-	0,5	0,5

KV202.05  
KV203.05

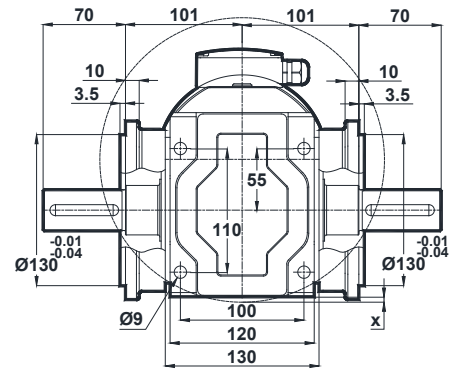
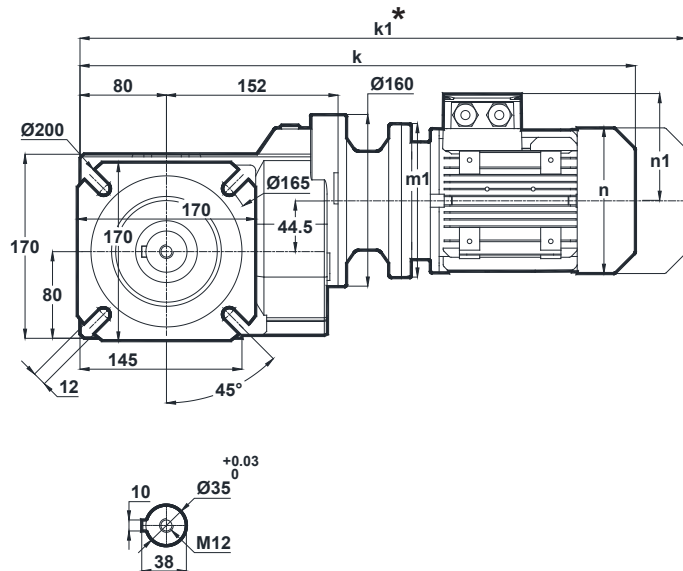

x: Motor Ayak bağlantı yüzeyinin altında ise  
x: If Motor is lower than foot mounting plane  
x: Wenn der Motor unter der Fußmontageebene ist

	63/B5	71/B5 71/B14	80/B580/ B14	90S/B5 90S/B14	90L/B5 90L/B14	100L/B5 100L/B14	112M/B5 112M/B14
k	469	488	540	581	581	609	630
k1	530	579	633	685.5	685.5	728.5	734.5
n / n1	121 / 97	137 / 112	155 / 121	176 / 132	176 / 132	193 / 147	215 / 158
m1 (B5)	140	160	200	200	200	250	250
m1 (B14)	-	105	120	140	140	160	160
x	-	-	-	-	-	0,5	0,5

\* " k1 " Ölçüsü frenli redüktörlere aittir.  
Dimension " k1 " is for motors with brake.  
Maße " k1 " ist für Bremsmotoren.



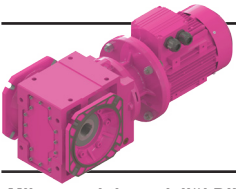

# Ölçü Sayfaları Dimension Pages Abmessungsseiten



-Mil ucu çektirme deliği DIN 332 sayfa 2 / Tapped center hole to DIN 332, sheet 2 / Zentrierung mit Gewinde DIN 332, Blatt 2

KV202.08  
KV203.08

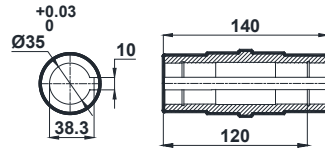
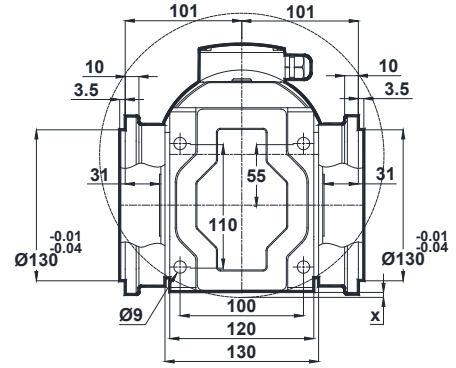
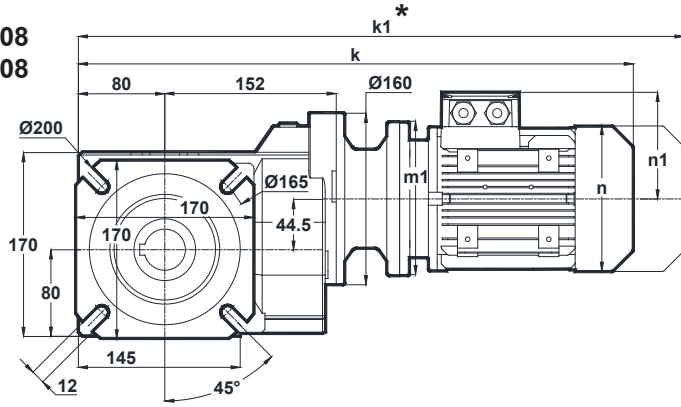

x: Motor Ayak bağlantı yüzeyinin altında ise  
x: If Motor is lower than foot mounting plane  
x: Wenn der Motor unter der Fußmontageebene ist

Klemens Pozisyonları  
Terminal Box Positions  
Klemmenkasten Positionen

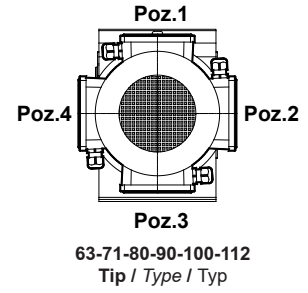

	63/B5	71/B5 71/B14	80/B580/ B14	90S/B5 90S/B14	90L/B5 90L/B14	100L/B5 100L/B14	112M/B5 112M/B14
k	469	488	540	581	581	609	630
k1	530	579	633	685.5	685.5	728.5	734.5
n / n1	121 / 97	137 / 112	155 / 121	176 / 132	176 / 132	193 / 147	215 / 158
m1 (B5)	140	160	200	200	200	250	250
m1 (B14)	-	105	120	140	140	160	160
x	-	-	-	-	-	0,5	0,5

\* " k1 " Ölçüsü frenli redüktörlere aittir.  
Dimension " k1 " is for motors with brake.  
Maße " k1 " ist für Bremsenmotoren.

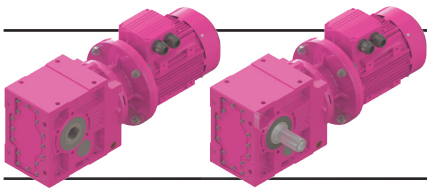

# Ölçü Sayfaları

## Dimension Pages

### Abmessungsseiten

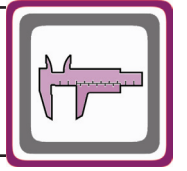

-Mil ucu çektirme deliği DIN 332 sayfa 2 / Tapped center hole to DIN 332, sheet 2 / Zentrierung mit Gewinde DIN 332, Blatt 2

#### KV273.00

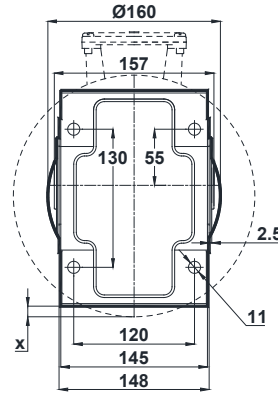
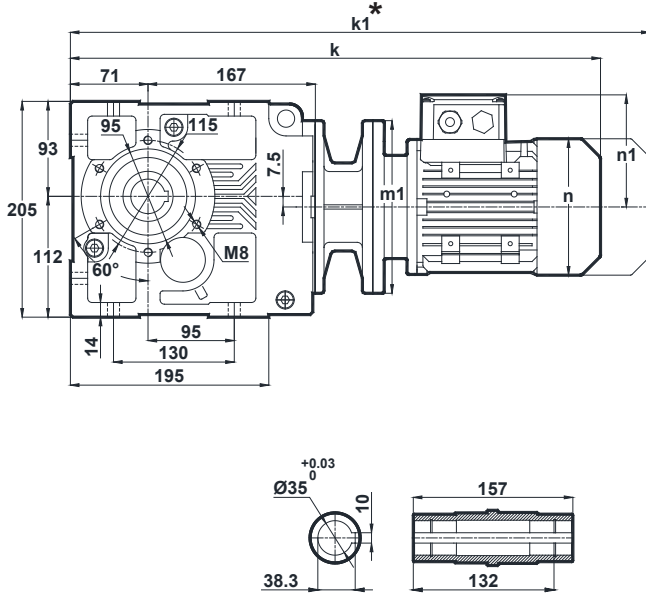

x: Motor Ayak bağlantı yüzeyinin altında ise  
x: If Motor is lower than foot mounting plane  
x: Wenn der Motor unter der Fußmontageebene ist

**Klemens Pozisyonları**  
Terminal Box Positions  
Klemmenkasten Positionen

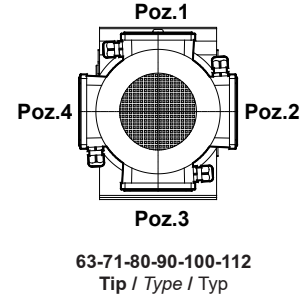

	63/B5	71/B5 71/B14	80/B5 80/B14	90S/B5 90S/B14	90L/B5 90L/B14	100L/B5 100L/B14	112M/B5 112M/B14
k	505	494	546	587	587	615	636
k1	566	585	639	691.5	691.5	734.5	740.5
n / n1	121 / 97	137 / 112	155 / 121	176 / 132	176 / 132	193 / 147	215 / 158
m1 (B5)	140	160	200	200	200	250	250
m1 (B14)	-	105	120	140	140	160	160
x	-	-	-	-	-	20,5	20,5

#### KV273.01

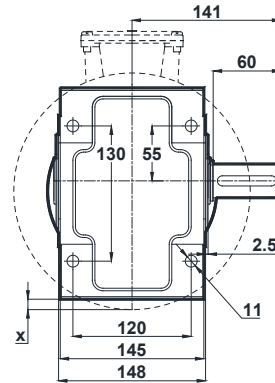
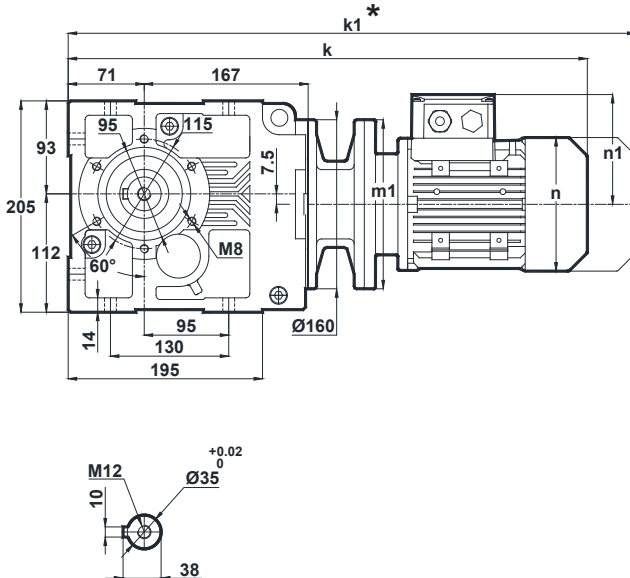

x: Motor Ayak bağlantı yüzeyinin altında ise  
x: If Motor is lower than foot mounting plane  
x: Wenn der Motor unter der Fußmontageebene ist

	63/B5	71/B5 71/B14	80/B5 80/B14	90S/B5 90S/B14	90L/B5 90L/B14	100L/B5 100L/B14	112M/B5 112M/B14
k	505	494	546	587	587	615	636
k1	566	585	639	691.5	691.5	734.5	740.5
n / n1	121 / 97	137 / 112	155 / 121	176 / 132	176 / 132	193 / 147	215 / 158
m1 (B5)	140	160	200	200	200	250	250
m1 (B14)	-	105	120	140	140	160	160
x	-	-	-	-	-	20,5	20,5

\* "k1" Ölçüsü frenli redüktörlere aittir.  
Dimension "k1" is for motors with brake.  
Maße "k1" ist für Bremsmotoren.

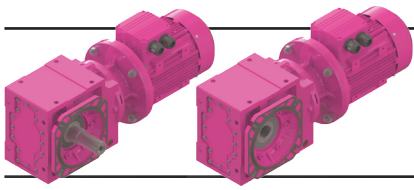

# Ölçü Sayfaları

## Dimension Pages

### Abmessungsseiten



-Mil ucu çektirme deliği DIN 332 sayfa 2 / Tapped center hole to DIN 332, sheet 2 / Zentrierung mit Gewinde DIN 332, Blatt 2

#### KV273.02

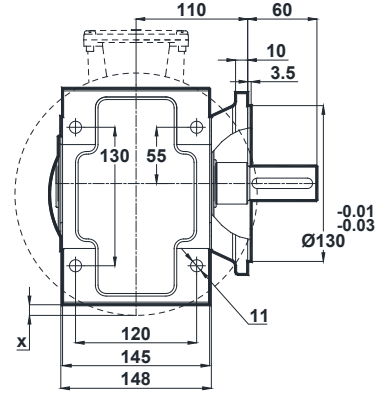
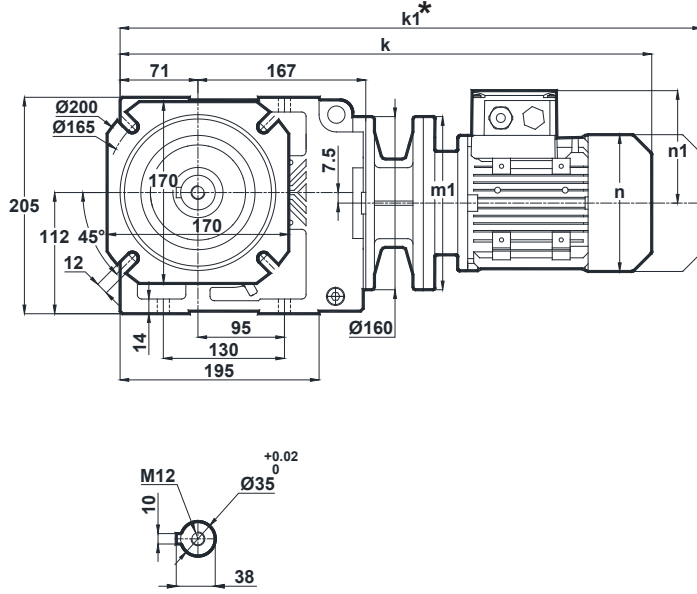

x: Motor Ayak bağlantı yüzeyinin altında ise  
x: If Motor is lower than foot mounting plane  
x: Wenn der Motor unter der Fußmontageebene ist

Klemens Pozisyonları  
Terminal Box Positions  
Klemmenkasten Positionen

	63/B5	71/B5 71/B14	80/B5 80/B14	90S/B5 90S/B14	90L/B5 90L/B14	100L/B5 100L/B14	112M/B5 112M/B14
k	505	494	546	587	587	615	636
k1	566	585	639	691.5	691.5	734.5	740.5
n / n1	121 / 97	137 / 112	155 / 121	176 / 132	176 / 132	193 / 147	215 / 158
m1 (B5)	140	160	200	200	200	250	250
m1 (B14)	-	105	120	140	140	160	160
x	-	-	-	-	-	20,5	20,5

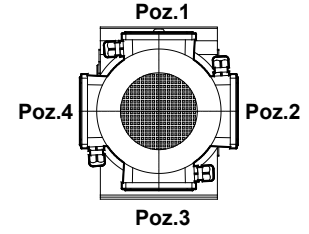

63-71-80-90-100-112  
Tip / Type / Typ

#### KV273.03

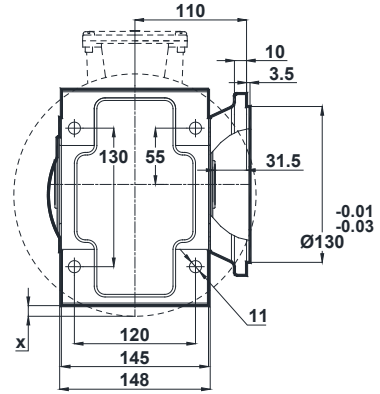
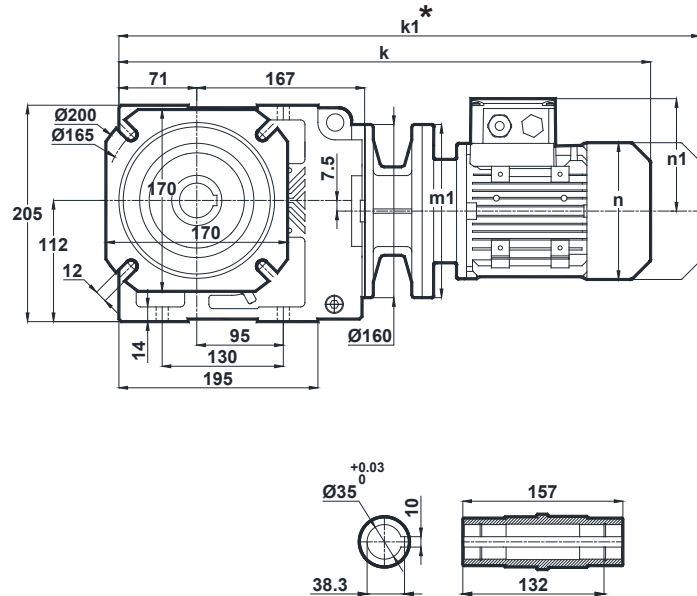

x: Motor Ayak bağlantı yüzeyinin altında ise  
x: If Motor is lower than foot mounting plane  
x: Wenn der Motor unter der Fußmontageebene ist

	63/B5	71/B5 71/B14	80/B5 80/B14	90S/B5 90S/B14	90L/B5 90L/B14	100L/B5 100L/B14	112M/B5 112M/B14
k	505	494	546	587	587	615	636
k1	566	585	639	691.5	691.5	734.5	740.5
n / n1	121 / 97	137 / 112	155 / 121	176 / 132	176 / 132	193 / 147	215 / 158
m1 (B5)	140	160	200	200	200	250	250
m1 (B14)	-	105	120	140	140	160	160
x	-	-	-	-	-	20,5	20,5

\* " k1 " Ölçüsü frenli redüktörlere aittir.  
Dimension " k1 " is for motors with brake.  
Maße " k1 " ist für Bremsenmotoren.

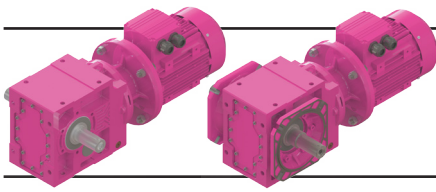

# Ölçü Sayfaları

## Dimension Pages

### Abmessungsseiten

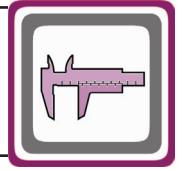

-Mil ucu çekirme deliği DIN 332 sayfa 2 / Tapped center hole to DIN 332, sheet 2 / Zentrierung mit Gewinde DIN 332, Blatt 2

#### KV273.04

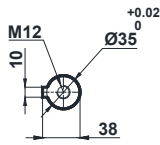
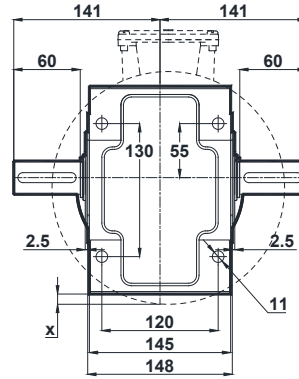
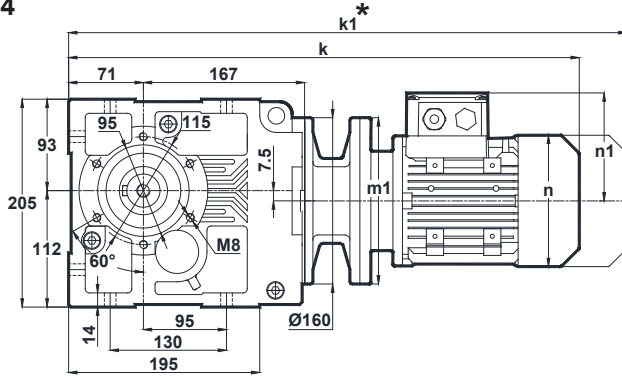

x: Motor Ayak bağlantı yüzeyinin altında ise  
x: If Motor is lower than foot mounting plane  
x: Wenn der Motor unter der Fußmontageebene ist

**Klemens Pozisyonları**  
Terminal Box Positions  
Klemmenkasten Positionen

	63/B5	71/B5 71/B14	80/B5 80/B14	90S/B5 90S/B14	90L/B5 90L/B14	100L/B5 100L/B14	112M/B5 112M/B14
k	505	494	546	587	587	615	636
k1	566	585	639	691.5	691.5	734.5	740.5
n / n1	121 / 97	137 / 112	155 / 121	176 / 132	176 / 132	193 / 147	215 / 158
m1 (B5)	140	160	200	200	200	250	250
m1 (B14)	-	105	120	140	140	160	160
x	-	-	-	-	-	20,5	20,5

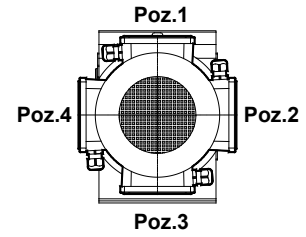

63-71-80-90-100-112  
Tip / Type / Typ

#### KV273.05

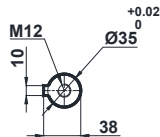
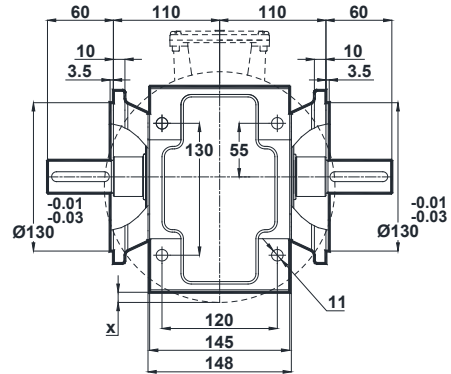
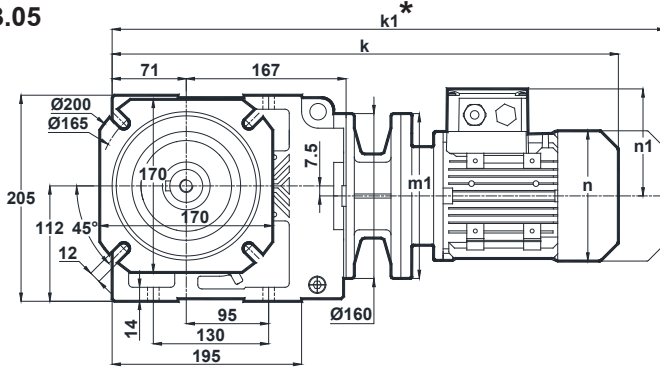

x: Motor Ayak bağlantı yüzeyinin altında ise  
x: If Motor is lower than foot mounting plane  
x: Wenn der Motor unter der Fußmontageebene ist

	63/B5	71/B5 71/B14	80/B5 80/B14	90S/B5 90S/B14	90L/B5 90L/B14	100L/B5 100L/B14	112M/B5 112M/B14
k	505	494	546	587	587	615	636
k1	566	585	639	691.5	691.5	734.5	740.5
n / n1	121 / 97	137 / 112	155 / 121	176 / 132	176 / 132	193 / 147	215 / 158
m1 (B5)	140	160	200	200	200	250	250
m1 (B14)	-	105	120	140	140	160	160
x	-	-	-	-	-	20,5	20,5

\* " k1 " Ölçüsü frenli redüktörlere aittir.  
Dimension " k1 " is for motors with brake.  
Maße " k1 " ist für Bremsenmotoren.

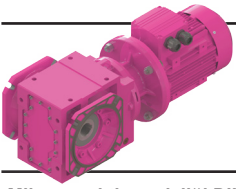

# Ölçü Sayfaları Dimension Pages Abmessungsseiten

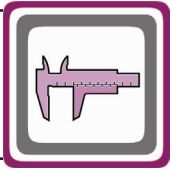

-Mil ucu çektirme deliği DIN 332 sayfa 2 / Tapped center hole to DIN 332, sheet 2 / Zentrierung mit Gewinde DIN 332, Blatt 2

KV273.08

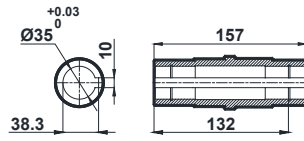
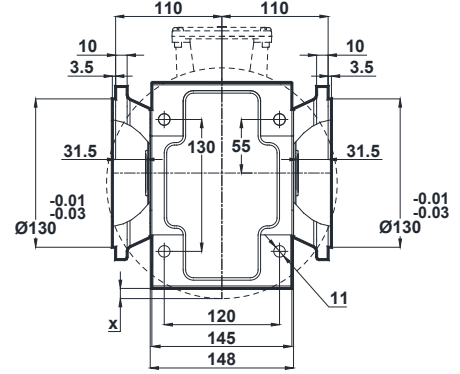
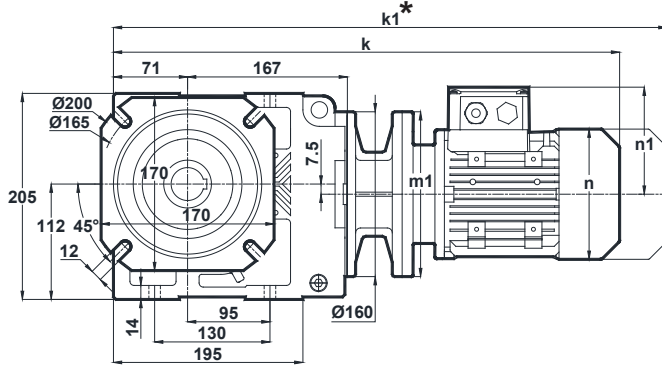

x: Motor Ayak bağlantı yüzeyinin altında ise  
x: If Motor is lower than foot mounting plane  
x: Wenn der Motor unter der Fußmontageebene ist

Klemens Pozisyonları  
Terminal Box Positions  
Klemmenkasten Positionen

	63/B5	71/B5 71/B14	80/B5 80/B14	90S/B5 90S/B14	90L/B5 90L/B14	100L/B5 100L/B14	112M/B5 112M/B14
k	505	494	546	587	587	615	636
k1	566	585	639	691.5	691.5	734.5	740.5
n / n1	121 / 97	137 / 112	155 / 121	176 / 132	176 / 132	193 / 147	215 / 158
m1 (B5)	140	160	200	200	200	250	250
m1 (B14)	-	105	120	140	140	160	160
x	-	-	-	-	-	20,5	20,5

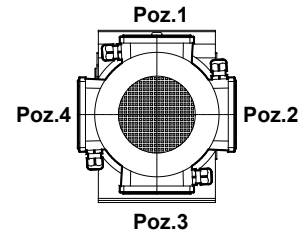

63-71-80-90-100-112  
Tip / Type / Typ

\* " k1 " Ölçüsü frenli redüktörlere aittir.  
Dimension " k1 " is for motors with brake.  
Maße " k1 " ist für Bremsenmotoren.

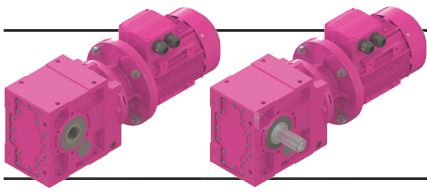

# Ölçü Sayfaları

## Dimension Pages

### Abmessungsseiten

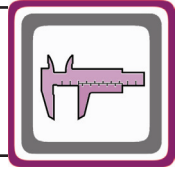

-Mil ucu çektirme deliği DIN 332 sayfa 2 / Tapped center hole to DIN 332, sheet 2 / Zentrierung mit Gewinde DIN 332, Blatt 2

KV275.00  
KV276.00

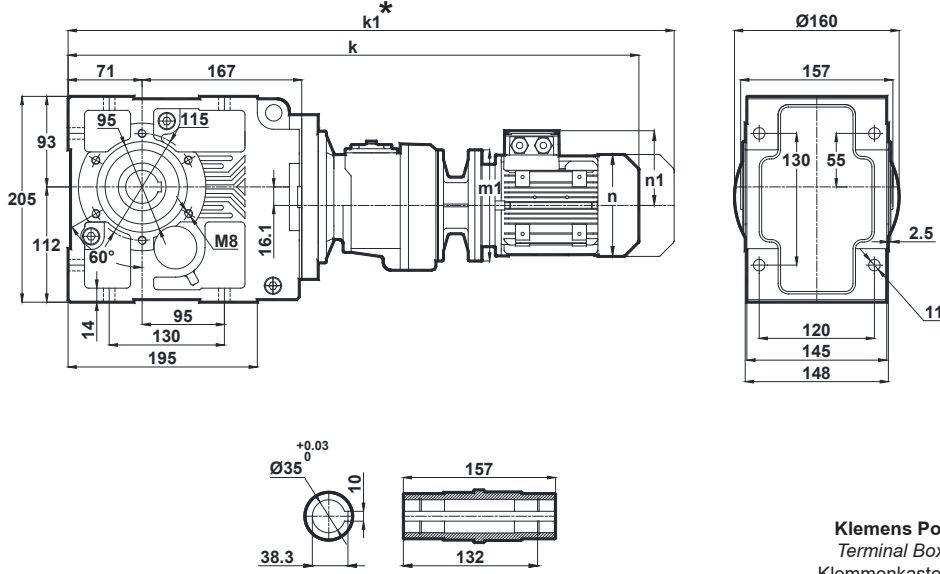

	63/B5 63/B14	71/B5 71/B14	80/B5 80/B14
k	620	640	678
k1	681	731	771
n / n1	121 / 97	137 / 112	155 / 121
m1 (B5)	140	160	200
m1 (B14)	90	105	120

**Klemens Pozisyonları**  
Terminal Box Positions  
Klemmenkasten Positionen

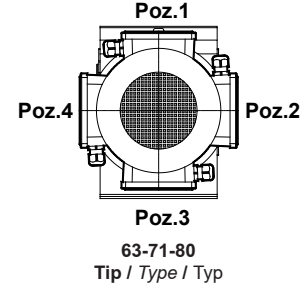

KV275.01  
KV276.01

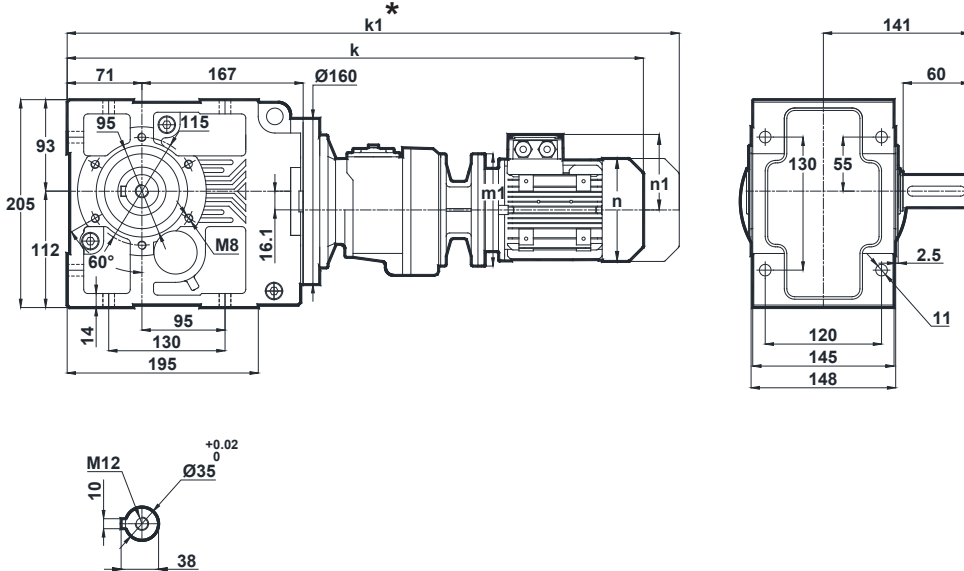

	63/B5 63/B14	71/B5 71/B14	80/B5 80/B14
k	620	640	678
k1	681	731	771
n / n1	121 / 97	137 / 112	155 / 121
m1 (B5)	140	160	200
m1 (B14)	90	105	120

\* " k1 " Ölçüsü frenli redüktörlere aittir.  
Dimension " k1 " is for motors with brake.  
Maße " k1 " ist für Bremsenmotoren.

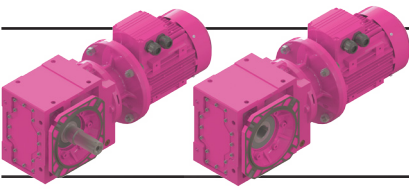

# Ölçü Sayfaları

## Dimension Pages

### Abmessungsseiten

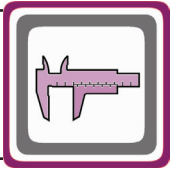

-Mil ucu çekirme deliği DIN 332 sayfa 2 / Tapped center hole to DIN 332, sheet 2 / Zentrierung mit Gewinde DIN 332, Blatt 2

KV275.02  
KV276.02

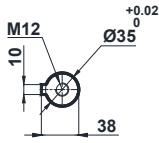
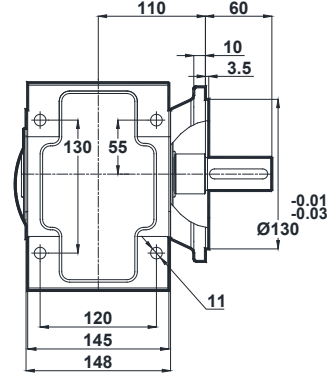
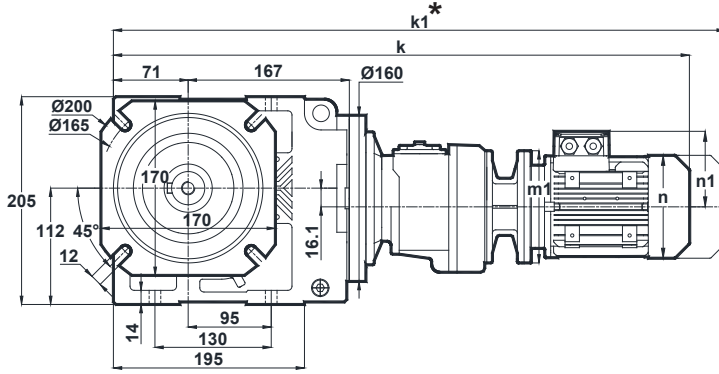

	63/B5 63/B14	71/B5 71/B14	80/B5 80/B14
k	620	640	678
k1	681	731	771
n / n1	121 / 97	137 / 112	155 / 121
m1 (B5)	140	160	200
m1 (B14)	90	105	120

Klemens Pozisyonları  
Terminal Box Positions  
Klemmenkasten Positionen

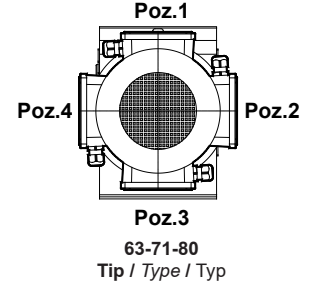

KV275.03  
KV276.03

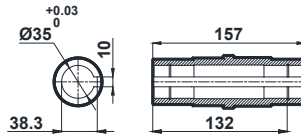
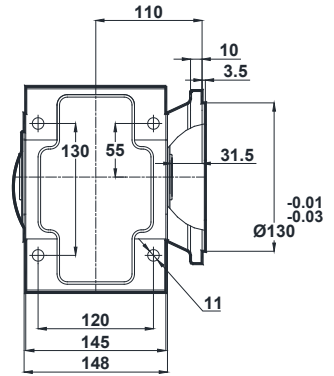
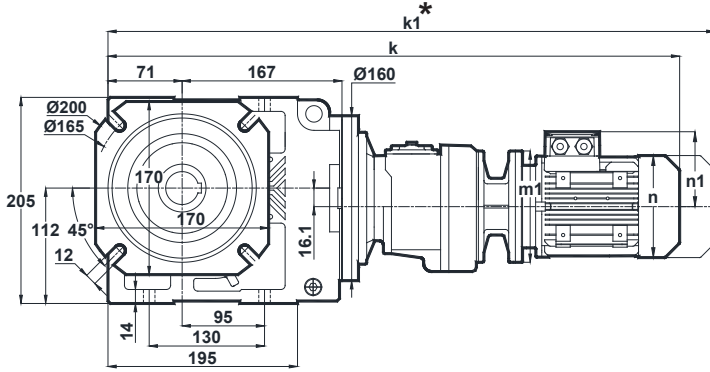

	63/B5 63/B14	71/B5 71/B14	80/B5 80/B14
k	620	640	678
k1	681	731	771
n / n1	121 / 97	137 / 112	155 / 121
m1 (B5)	140	160	200
m1 (B14)	90	105	120

\* " k1 " Ölçüsü frenli redüktörlere aittir.  
Dimension " k1 " is for motors with brake.  
Maße " k1 " ist für Bremsenmotoren.

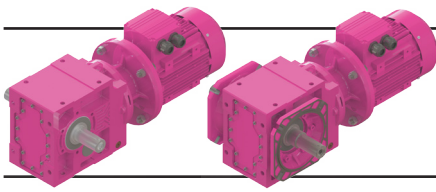

# Ölçü Sayfaları

## Dimension Pages

### Abmessungsseiten

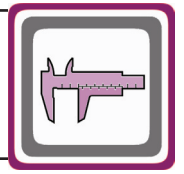

-Mil ucu çektirme deliği DIN 332 sayfa 2 / Tapped center hole to DIN 332, sheet 2 / Zentrierung mit Gewinde DIN 332, Blatt 2

KV275.04  
KV276.04

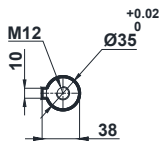
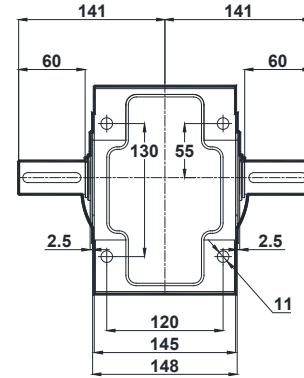
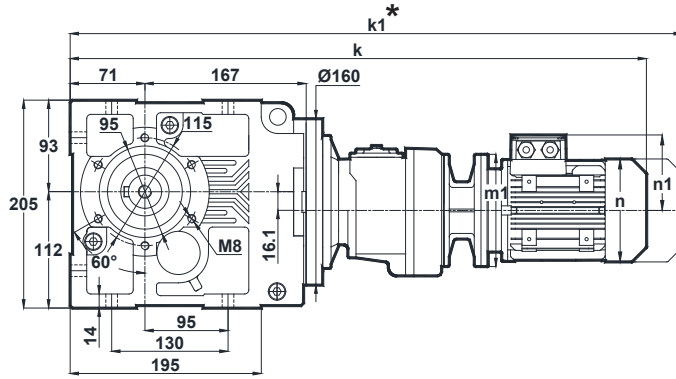

	63/B5 63/B14	71/B5 71/B14	80/B5 80/B14
k	620	640	678
k1	681	731	771
n / n1	121 / 97	137 / 112	155 / 121
m1 (B5)	140	160	200
m1 (B14)	90	105	120

Klemens Pozisyonları  
Terminal Box Positions  
Klemmenkasten Positionen

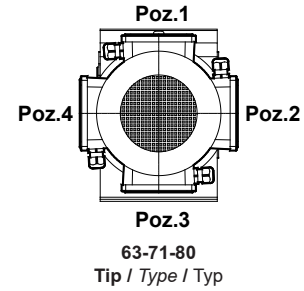

KV275.05  
KV276.05

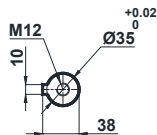
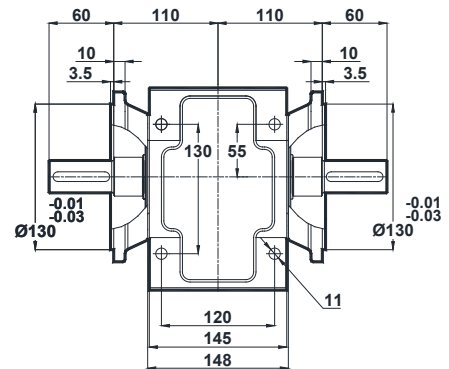
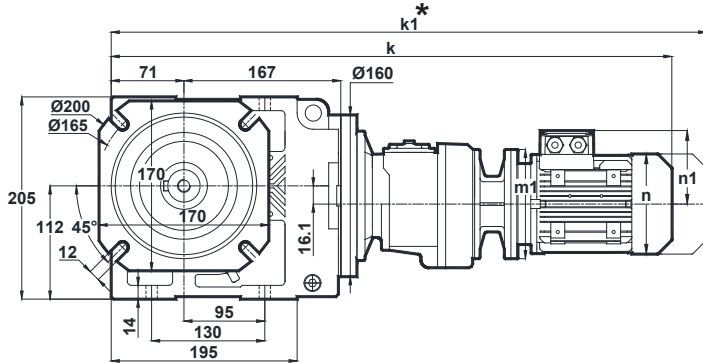

	63/B5 63/B14	71/B5 71/B14	80/B5 80/B14
k	620	640	678
k1	681	731	771
n / n1	121 / 97	137 / 112	155 / 121
m1 (B5)	140	160	200
m1 (B14)	90	105	120

\* " k1 " Ölçüsü frenli redüktörlere aittir.  
Dimension " k1 " is for motors with brake.  
Maße " k1 " ist für Bremsenmotoren.



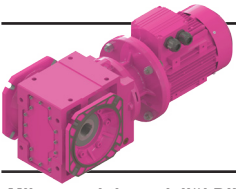

# Ölçü Sayfaları Dimension Pages Abmessungenseiten



-Mil ucu çekirme deliği DIN 332 sayfa 2 / Tapped center hole to DIN 332, sheet 2 / Zentrierung mit Gewinde DIN 332, Blatt 2

KV275.08  
KV276.08

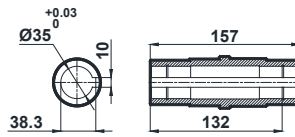
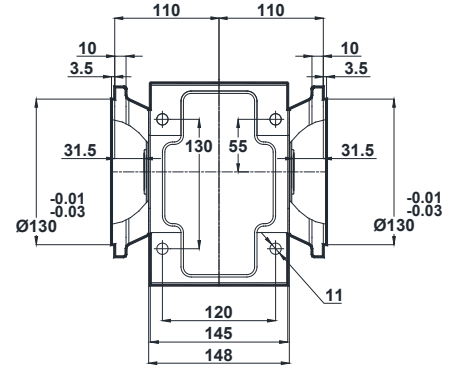
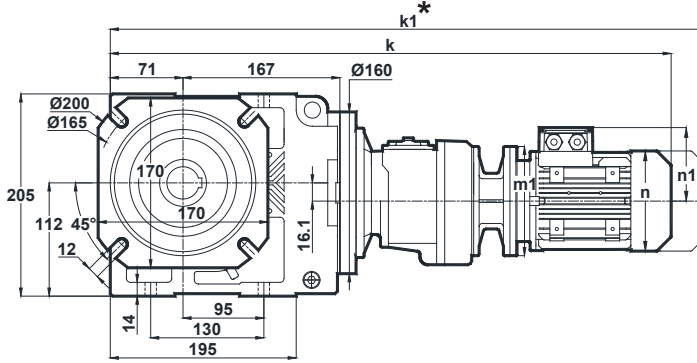

	63/B5 63/B14	71/B5 71/B14	80/B5 80/B14
k	620	640	678
k1	681	731	771
n / n1	121 / 97	137 / 112	155 / 121
m1 (B5)	140	160	200
m1 (B14)	90	105	120

Klemens Pozisyonları  
Terminal Box Positions  
Klemmenkasten Positionen

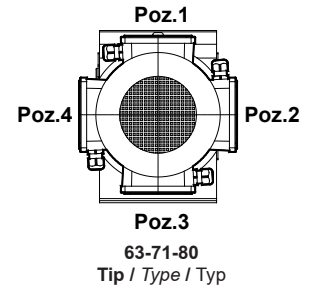

\* " k1 " Ölçüsü frenli redüktörlere aittir.  
Dimension " k1 " is for motors with brake.  
Maße " k1 " ist für Bremsenmotoren.



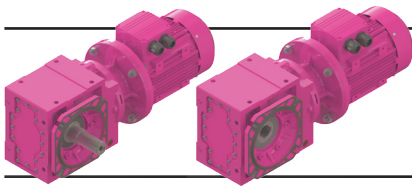

# Ölçü Sayfaları

## Dimension Pages

### Abmessungsseiten

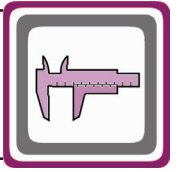

-Mil ucu çektirme deliği DIN 332 sayfa 2 / Tapped center hole to DIN 332, sheet 2 / Zentrierung mit Gewinde DIN 332, Blatt 2

KV373.02  
KV373.02

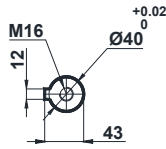
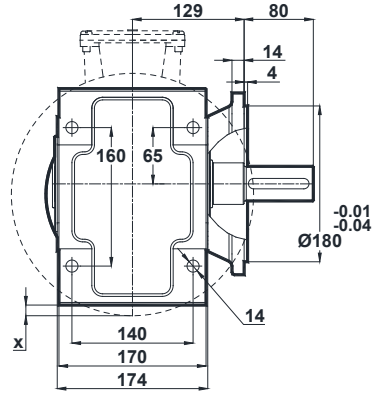
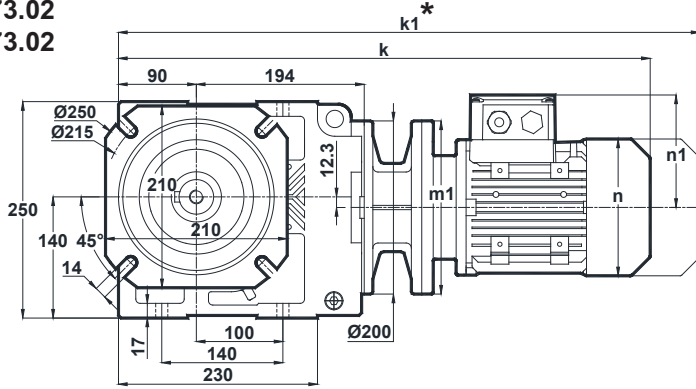

x: Motor Ayak bağlantı yüzeyinin altında ise  
x: If Motor is lower than foot mounting plane  
x: Wenn der Motor unter der Fußmontageebene ist

Klemens Pozisyonları  
Terminal Box Positions  
Klemmenkasten Positionen

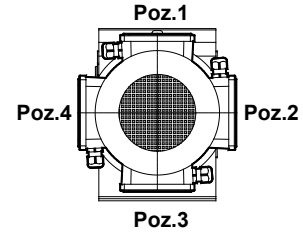

71-80-90-100-112-132  
Tip / Type / Typ

	71/B5	80/B5 80/B14	90S/B5 90S/B14	90L/B5 90L/B14	100L/B5 100L/B14	112M/B5 112M/B14	132S/B5 132S/B14	132M/B5 132M/B14
k	562	585	626	626	678	699	803	803
k1	653	678	730.5	730.5	797.5	803.5	933	933
n / n1	137 / 112	155 / 121	176 / 132	176 / 132	193 / 147	215 / 158	257 / 179	257 / 179
m1 (B5)	160	200	200	200	250	250	300	300
m1 (B14)	-	120	140	140	160	160	200	200
x	-	-	-	-	-	-	22,3	22,3

KV373.03

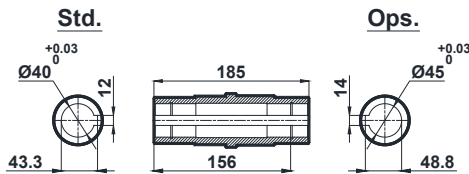
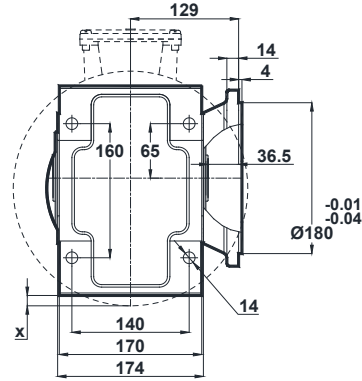
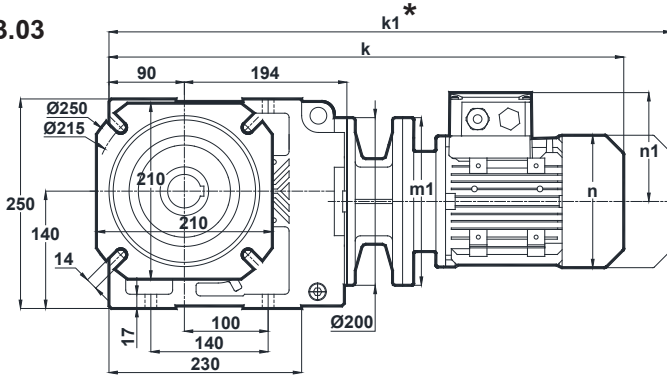

x: Motor Ayak bağlantı yüzeyinin altında ise  
x: If Motor is lower than foot mounting plane  
x: Wenn der Motor unter der Fußmontageebene ist

	71/B5	80/B5 80/B14	90S/B5 90S/B14	90L/B5 90L/B14	100L/B5 100L/B14	112M/B5 112M/B14	132S/B5 132S/B14	132M/B5 132M/B14
k	562	585	626	626	678	699	803	803
k1	653	678	730.5	730.5	797.5	803.5	933	933
n / n1	137 / 112	155 / 121	176 / 132	176 / 132	193 / 147	215 / 158	257 / 179	257 / 179
m1 (B5)	160	200	200	200	250	250	300	300
m1 (B14)	-	120	140	140	160	160	200	200
x	-	-	-	-	-	-	22,3	22,3

\* "k1" Ölçüsü frenli redüktörlere aittir.  
Dimension "k1" is for motors with brake.  
Maße "k1" ist für Bremsenmotoren.

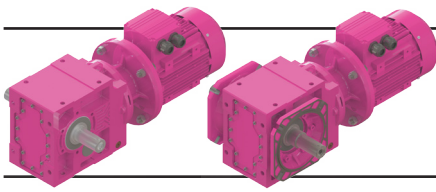

# Ölçü Sayfaları

## Dimension Pages

### Abmessungsseiten

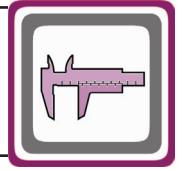

-Mil ucu çektirme deliği DIN 332 sayfa 2 / Tapped center hole to DIN 332, sheet 2 / Zentrierung mit Gewinde DIN 332, Blatt 2

KV373.04  
KV373.04

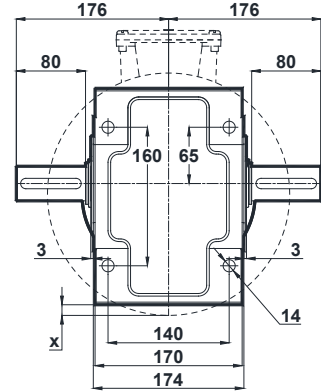
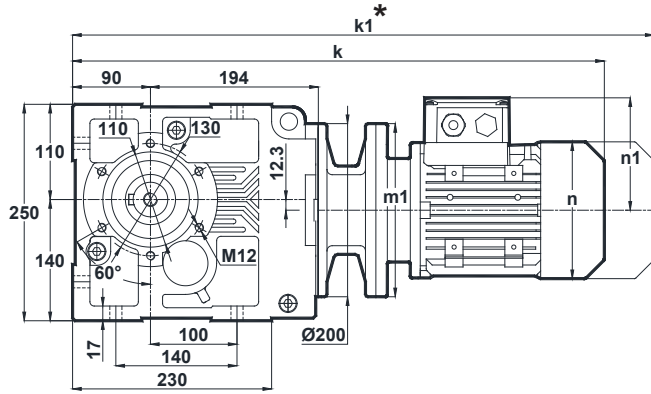

x: Motor Ayak bağlantı yüzeyinin altında ise  
x: If Motor is lower than foot mounting plane  
x: Wenn der Motor unter der Fußmontageebene ist

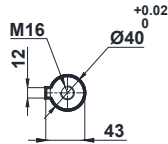

**Klemens Pozisyonları**  
Terminal Box Positions  
Klemmenkasten Positionen

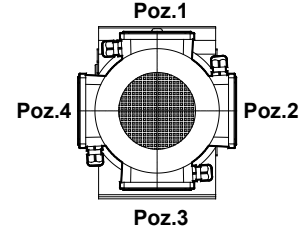

71-80-90-100-112-132  
Tip / Type / Typ

	71/B5	80/B5 80/B14	90S/B5 90S/B14	90L/B5 90L/B14	100L/B5 100L/B14	112M/B5 112M/B14	132S/B5 132S/B14	132M/B5 132M/B14
k	562	585	626	626	678	699	803	803
k1	653	678	730.5	730.5	797.5	803.5	933	933
n / n1	137 / 112	155 / 121	176 / 132	176 / 132	193 / 147	215 / 158	257 / 179	257 / 179
m1 (B5)	160	200	200	200	250	250	300	300
m1 (B14)	-	120	140	140	160	160	200	200
x	-	-	-	-	-	-	22,3	22,3

KV373.05  
KV373.05

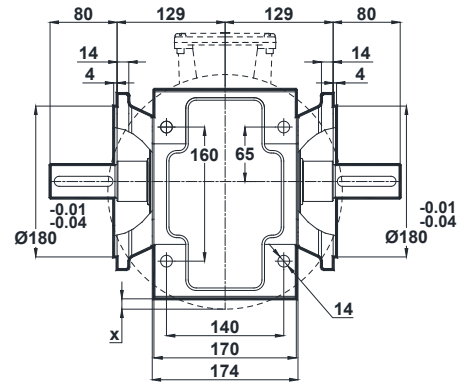
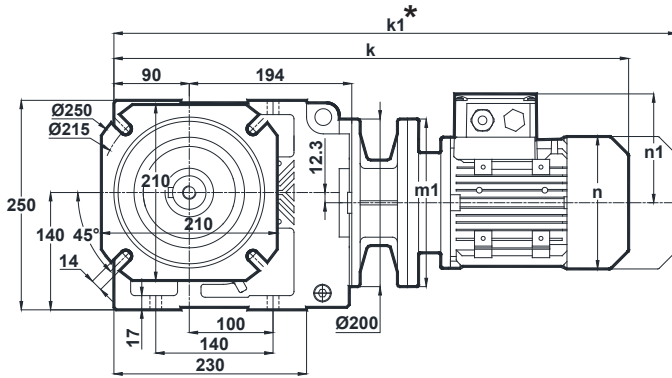

x: Motor Ayak bağlantı yüzeyinin altında ise  
x: If Motor is lower than foot mounting plane  
x: Wenn der Motor unter der Fußmontageebene ist

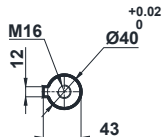

	71/B5	80/B5 80/B14	90S/B5 90S/B14	90L/B5 90L/B14	100L/B5 100L/B14	112M/B5 112M/B14	132S/B5 132S/B14	132M/B5 132M/B14
k	562	585	626	626	678	699	803	803
k1	653	678	730.5	730.5	797.5	803.5	933	933
n / n1	137 / 112	155 / 121	176 / 132	176 / 132	193 / 147	215 / 158	257 / 179	257 / 179
m1 (B5)	160	200	200	200	250	250	300	300
m1 (B14)	-	120	140	140	160	160	200	200
x	-	-	-	-	-	-	22,3	22,3

\* "k1" Ölçüsü frenli redüktörlere aittir.  
Dimension "k1" is for motors with brake.  
Maße "k1" ist für Bremsenmotoren.

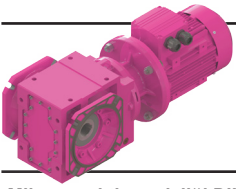

# Ölçü Sayfaları Dimension Pages Abmessungsseiten

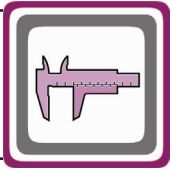

-Mil ucu çekirme deliği DIN 332 sayfa 2 / Tapped center hole to DIN 332, sheet 2 / Zentrierung mit Gewinde DIN 332, Blatt 2

KV373.08  
KV373.08

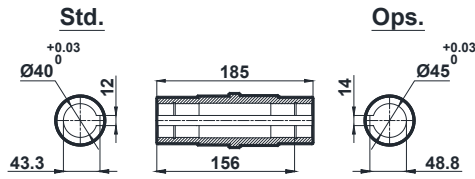
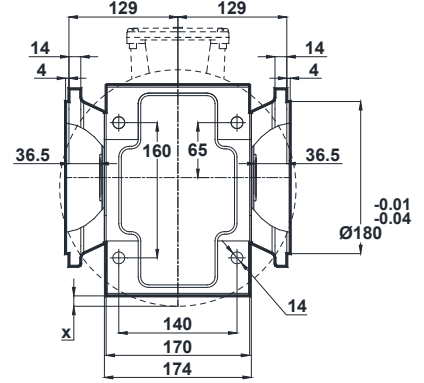
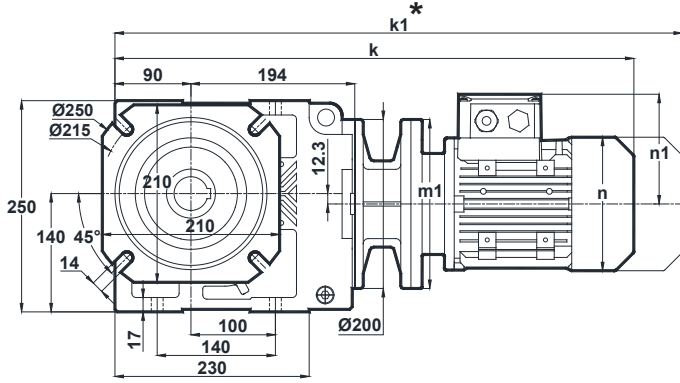

x: Motor Ayak bağlantı yüzeyinin altında ise  
x: If Motor is lower than foot mounting plane  
x: Wenn der Motor unter der Fußmontageebene ist

Klemens Pozisyonları  
Terminal Box Positions  
Klemmenkasten Positionen

	71/B5	80/B5 80/B14	90S/B5 90S/B14	90L/B5 90L/B14	100L/B5 100L/B14	112M/B5 112M/B14	132S/B5 132S/B14	132M/B5 132M/B14
k	562	585	626	626	678	699	803	803
k1	653	678	730.5	730.5	797.5	803.5	933	933
n / n1	137 / 112	155 / 121	176 / 132	176 / 132	193 / 147	215 / 158	257 / 179	257 / 179
m1 (B5)	160	200	200	200	250	250	300	300
m1 (B14)	-	120	140	140	160	160	200	200
x	-	-	-	-	-	-	22,3	22,3

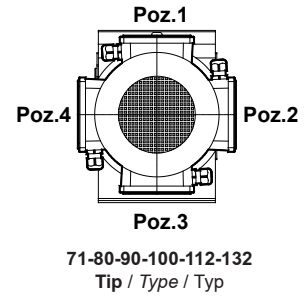

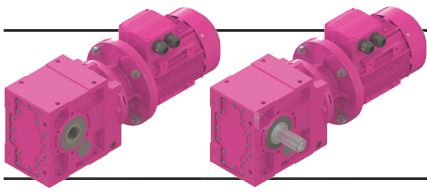

# Ölçü Sayfaları

## Dimension Pages

## Abmessungsseiten

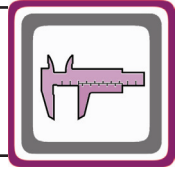

-Mil ucu çektirme deliği DIN 332 sayfa 2 / Tapped center hole to DIN 332, sheet 2 / Zentrierung mit Gewinde DIN 332, Blatt 2

### KV374.00

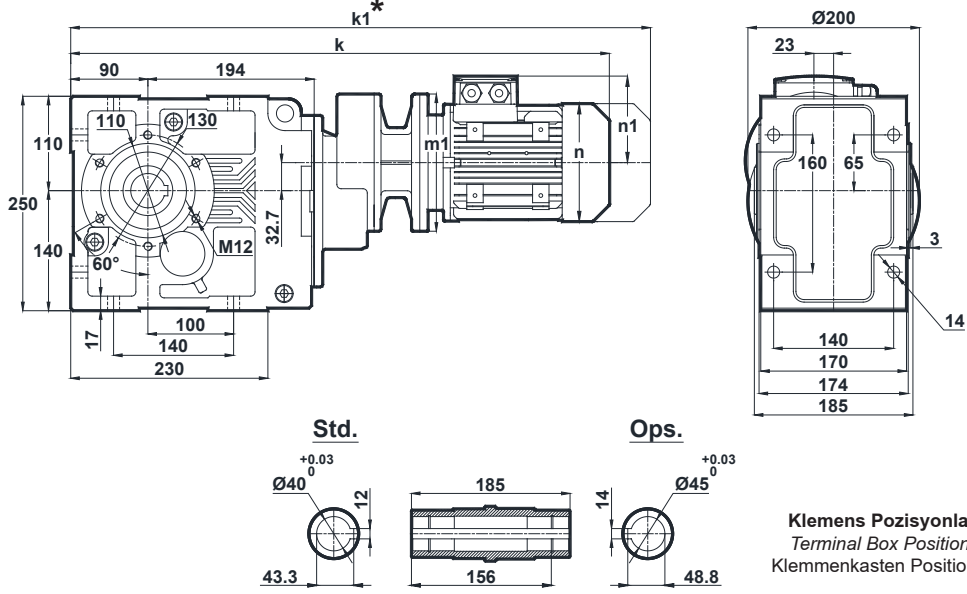

	63/B5	71/B5 71/B14	80/B5 80/B14
k	621	610	662
k1	682	701	755
n / n1	121 / 97	137 / 121	155 / 121
m1 (B5)	140	160	200
m1 (B14)	-	105	120

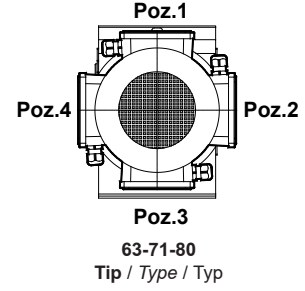

### KV374.01

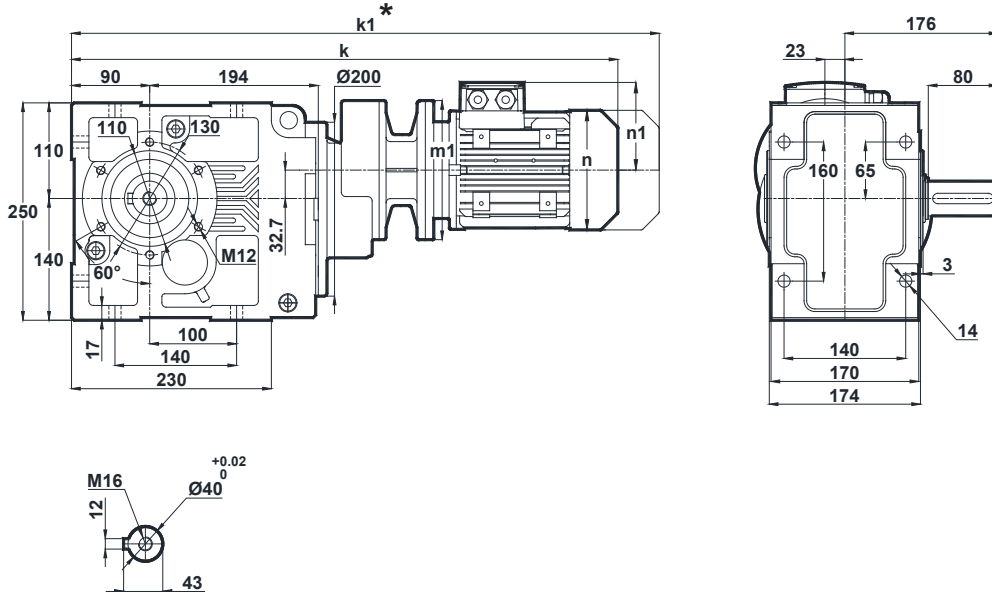

	63/B5	71/B5 71/B14	80/B5 80/B14
k	621	610	662
k1	682	701	755
n / n1	121 / 97	137 / 121	155 / 121
m1 (B5)	140	160	200
m1 (B14)	-	105	120

\* " k1 " Ölçüsü frenli redüktörlere aittir.  
Dimension " k1 " is for motors with brake.  
Maße " k1 " ist für Bremsmotoren.

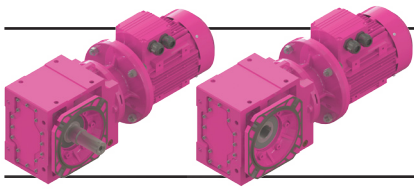

# Ölçü Sayfaları

## Dimension Pages

### Abmessungsseiten

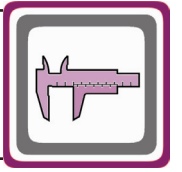

-Mil ucu çekirme deliği DIN 332 sayfa 2 / Tapped center hole to DIN 332, sheet 2 / Zentrierung mit Gewinde DIN 332, Blatt 2

#### KV374.02

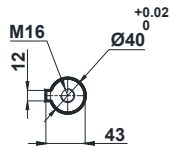
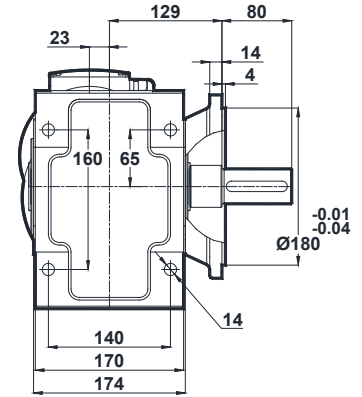
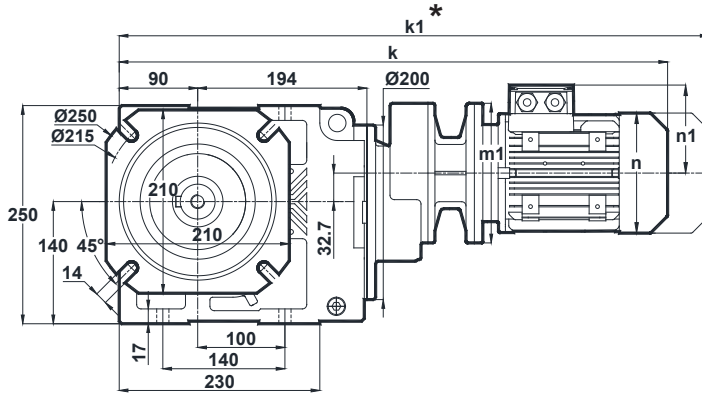

	63/B5	71/B5 71/B14	80/B5 80/B14
k	621	610	662
k1	682	701	755
n / n1	121 / 97	137 / 121	155 / 121
m1 (B5)	140	160	200
m1 (B14)	-	105	120

Klemens Pozisyonları  
Terminal Box Positions  
Klemmenkasten Positionen

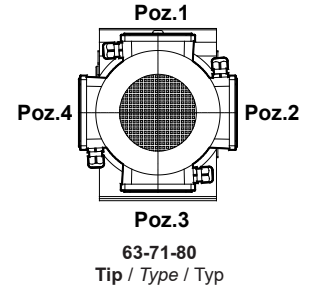

#### KV374.03

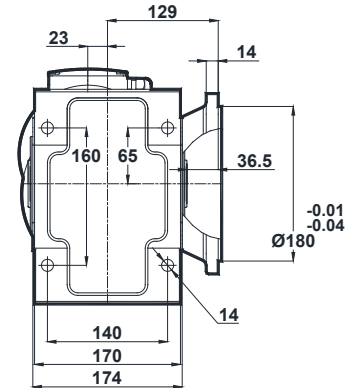
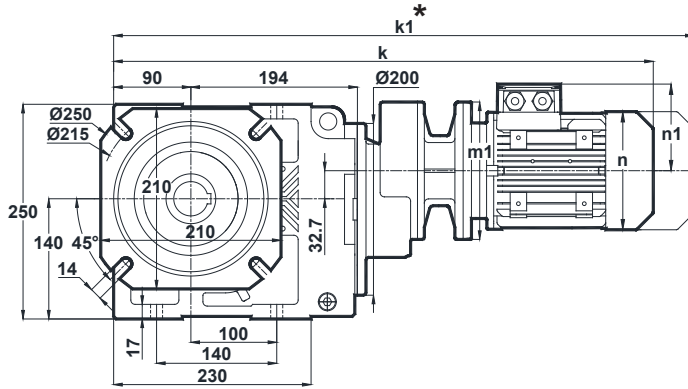

Std.



Ops.

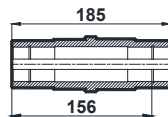
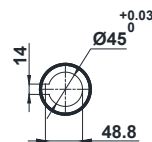

	63/B5	71/B5 71/B14	80/B5 80/B14
k	621	610	662
k1	682	701	755
n / n1	121 / 97	137 / 121	155 / 121
m1 (B5)	140	160	200
m1 (B14)	-	105	120

\* " k1 " Ölçüsü frenli redüktörlere aittir.  
Dimension " k1 " is for motors with brake.  
Maße " k1 " ist für Bremsenmotoren.

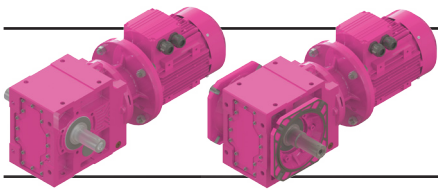

# Ölçü Sayfaları

## Dimension Pages

### Abmessungsseiten

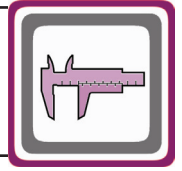

-Mil ucu çektirme deliği DIN 332 sayfa 2 / Tapped center hole to DIN 332, sheet 2 / Zentrierung mit Gewinde DIN 332, Blatt 2

#### KV374.04

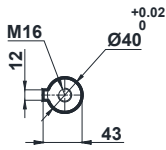
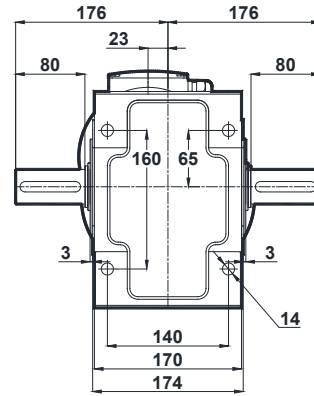
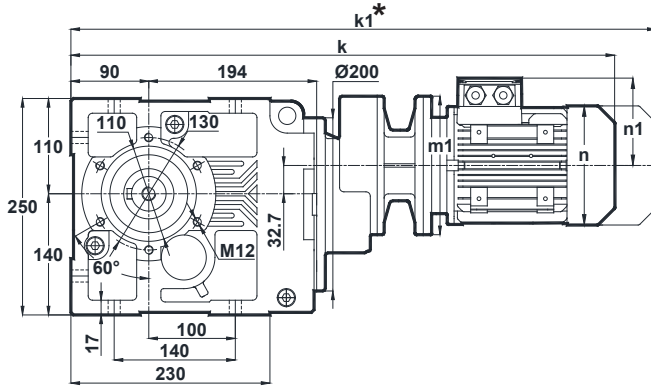

**Klemens Pozisyonları**  
Terminal Box Positions  
Klemmenkasten Positionen

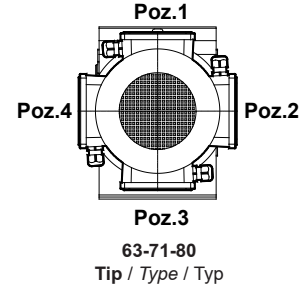

	63/B5	71/B5 71/B14	80/B5 80/B14
k	621	610	662
k1	682	701	755
n / n1	121 / 97	137 / 121	155 / 121
m1 (B5)	140	160	200
m1 (B14)	-	105	120

#### KV374.05

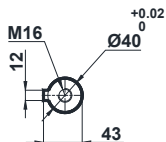
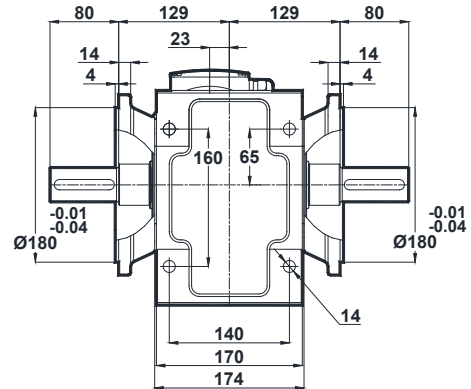
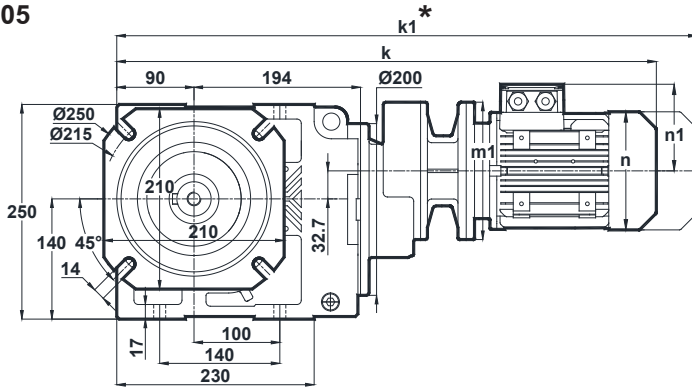

	63/B5	71/B5 71/B14	80/B5 80/B14
k	621	610	662
k1	682	701	755
n / n1	121 / 97	137 / 121	155 / 121
m1 (B5)	140	160	200
m1 (B14)	-	105	120

\* " k1 " Ölçüsü frenli redüktörlere aittir.  
Dimension " k1 " is for motors with brake.  
Maße " k1 " ist für Bremsmotoren.



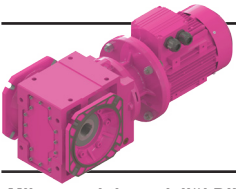

# Ölçü Sayfaları Dimension Pages Abmessungenseiten



-Mil ucu çekirme deliği DIN 332 sayfa 2 / Tapped center hole to DIN 332, sheet 2 / Zentrierung mit Gewinde DIN 332, Blatt 2

KV374.08

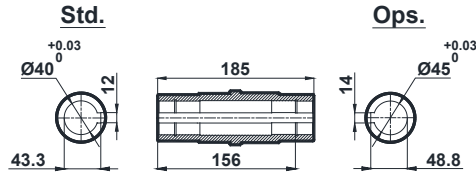
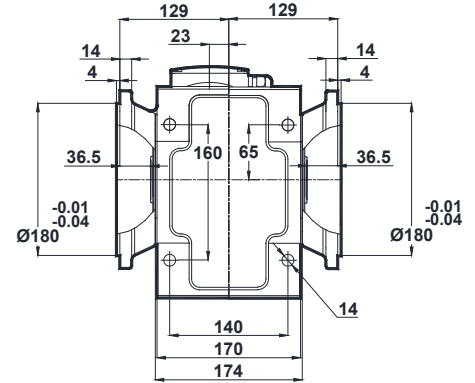
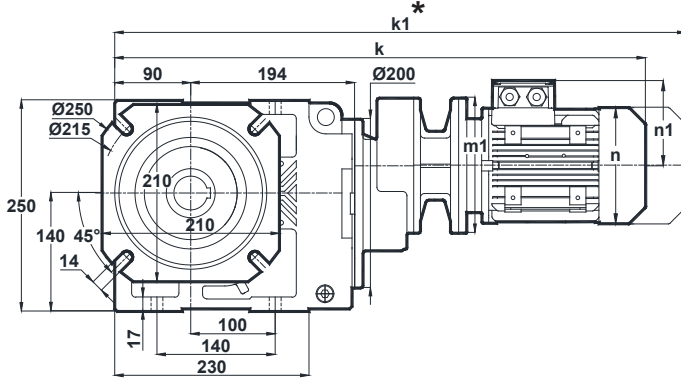

Klemens Pozisyonları  
Terminal Box Positions  
Klemmenkasten Positionen

	63/B5	71/B5 71/B14	80/B5 80/B14
k	621	610	662
k1	682	701	755
n / n1	121 / 97	137 / 121	155 / 121
m1 (B5)	140	160	200
m1 (B14)	-	105	120

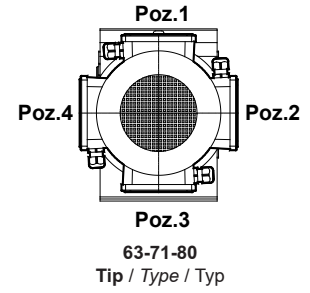

\* " k1 " Ölçüsü frenli redüktörlere aittir.  
Dimension " k1 " is for motors with brake.  
Maße " k1 " ist für Bremsenmotoren.

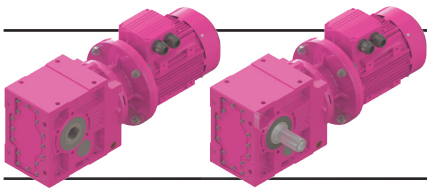

# Ölçü Sayfaları

## Dimension Pages

### Abmessungsseiten

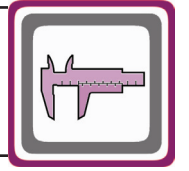

-Mil ucu çektirme deliği DIN 332 sayfa 2 / Tapped center hole to DIN 332, sheet 2 / Zentrierung mit Gewinde DIN 332, Blatt 2

KV375.00  
KV376.00

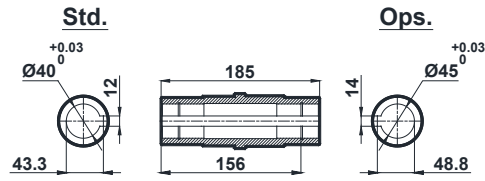
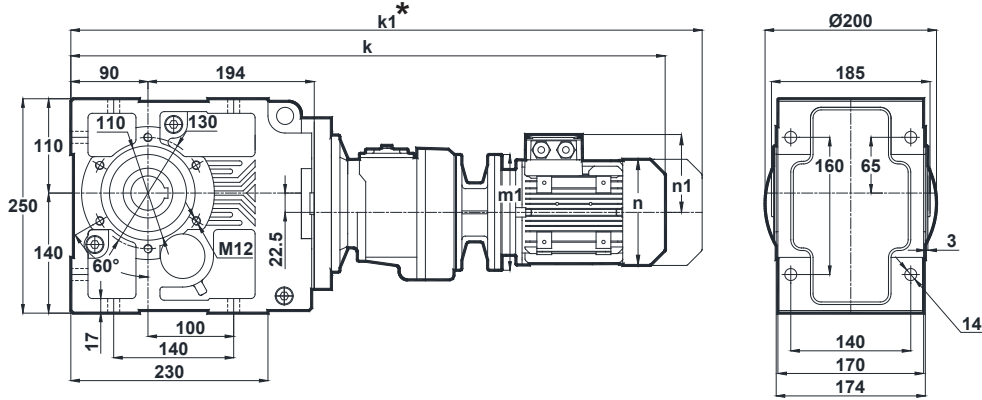

**Klemens Pozisyonları**  
Terminal Box Positions  
Klemmenkasten Positionen

	63/B5 63/B14	71/B5 71/B14
k	688	706
k1	749	797
n / n1	121 / 97	137 / 112
m1 (B5)	140	160
m1 (B14)	90	105

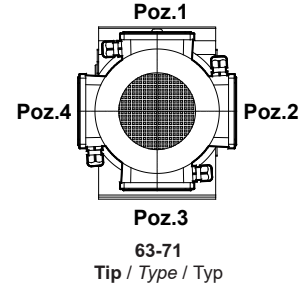

KV375.01  
KV376.01

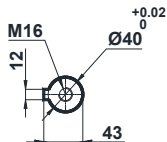
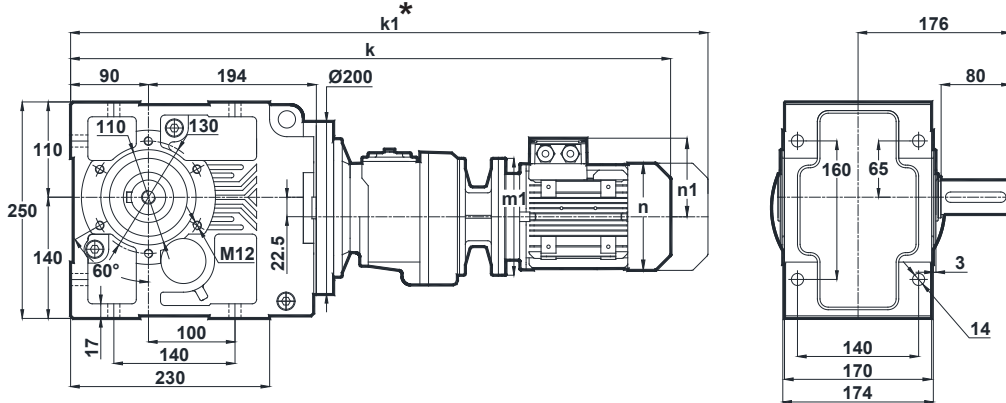

	63/B5 63/B14	71/B5 71/B14
k	688	706
k1	749	797
n / n1	121 / 97	137 / 112
m1 (B5)	140	160
m1 (B14)	90	105

\* " k1 " Ölçüsü frenli redüktörlere aittir.  
Dimension " k1 " is for motors with brake.  
Maße " k1 " ist für Bremsmotoren.

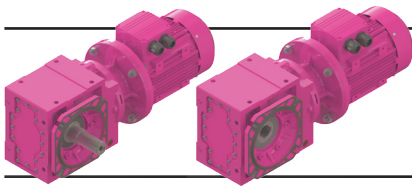

# Ölçü Sayfaları

## Dimension Pages

### Abmessungsseiten



-Mil ucu çekirme deliği DIN 332 sayfa 2 / Tapped center hole to DIN 332, sheet 2 / Zentrierung mit Gewinde DIN 332, Blatt 2

KV375.02  
KV376.02

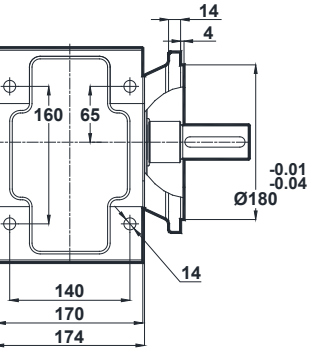
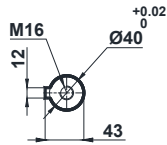
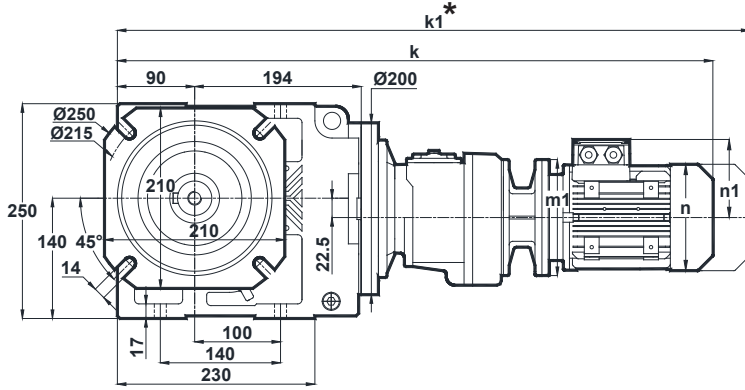

**Klemens Pozisyonları**  
Terminal Box Positions  
Klemmenkasten Positionen

	63/B5 63/B14	71/B5 71/B14
k	688	706
k1	749	797
n / n1	121 / 97	137 / 112
m1 (B5)	140	160
m1 (B14)	90	105

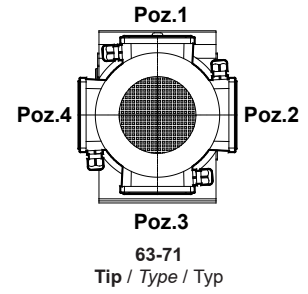

KV375.03  
KV376.03

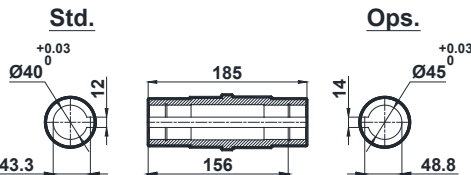
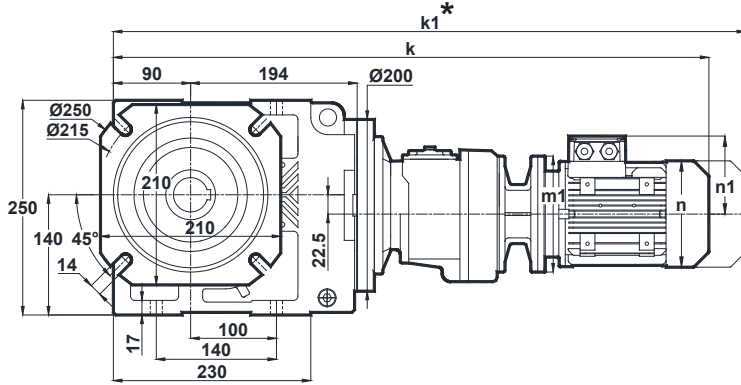

	63/B5 63/B14	71/B5 71/B14
k	688	706
k1	749	797
n / n1	121 / 97	137 / 112
m1 (B5)	140	160
m1 (B14)	90	105

\* " k1 " Ölçüsü frenli redüktörlere aittir.  
Dimension " k1 " is for motors with brake.  
Maße " k1 " ist für Bremsenmotoren.

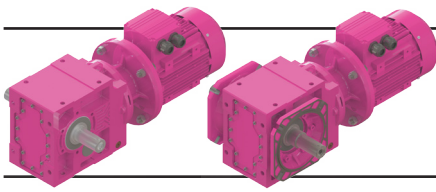

# Ölçü Sayfaları

## Dimension Pages

### Abmessungsseiten

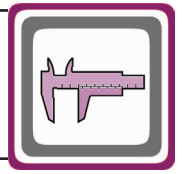

-Mil ucu çektirme deliği DIN 332 sayfa 2 / Tapped center hole to DIN 332, sheet 2 / Zentrierung mit Gewinde DIN 332, Blatt 2

KV375.04  
KV376.04

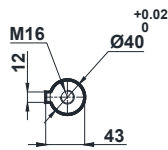
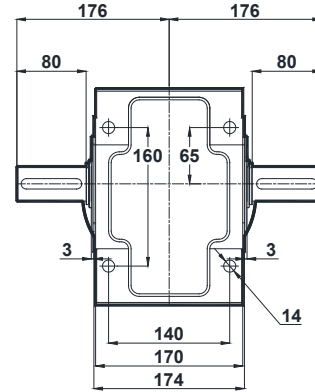
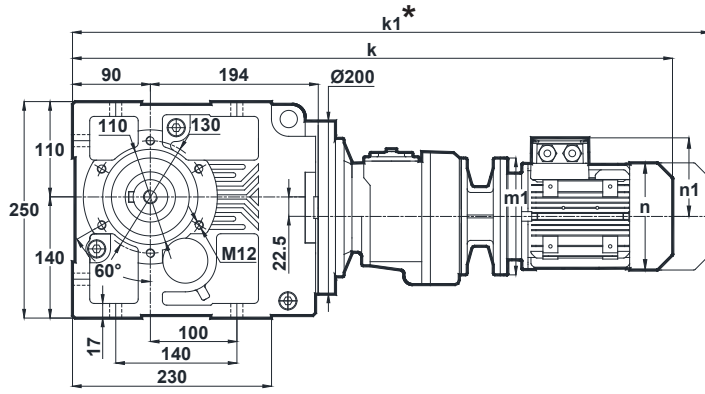

	63/B5 63/B14	71/B5 71/B14
k	688	706
k1	749	797
n / n1	121 / 97	137 / 112
m1 (B5)	140	160
m1 (B14)	90	105

**Klemens Pozisyonları**  
Terminal Box Positions  
Klemmenkasten Positionen

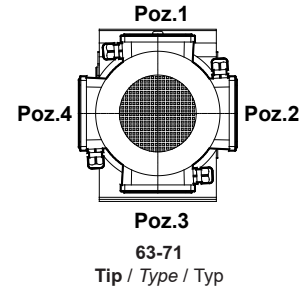

KV375.05  
KV376.05

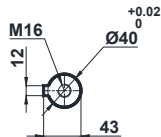
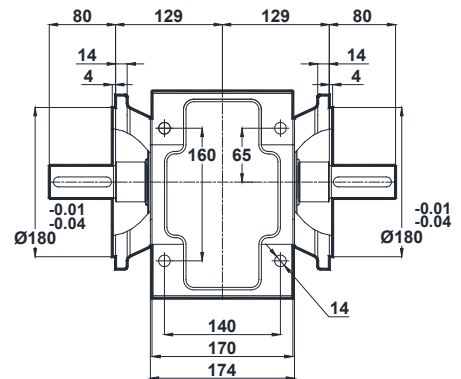
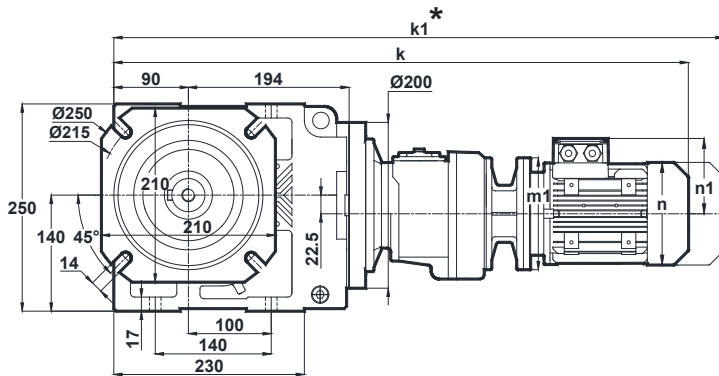

	63/B5 63/B14	71/B5 71/B14
k	688	706
k1	749	797
n / n1	121 / 97	137 / 112
m1 (B5)	140	160
m1 (B14)	90	105

\* "k1" Ölçüsü frenli redüktörlere aittir.  
Dimension "k1" is for motors with brake.  
Maße "k1" ist für Bremsenmotoren.

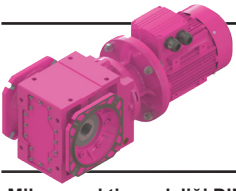

# Ölçü Sayfaları Dimension Pages Abmessungsseiten

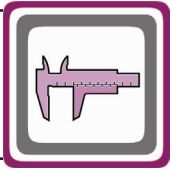

-Mil ucu çekirme deliği DIN 332 sayfa 2 / Tapped center hole to DIN 332, sheet 2 / Zentrierung mit Gewinde DIN 332, Blatt 2

KV375.08  
KV376.08

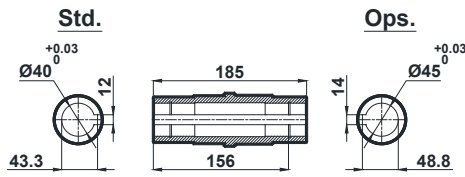
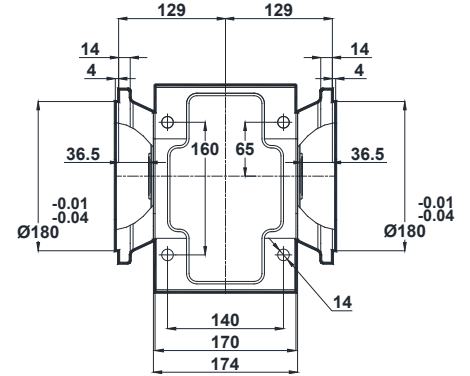
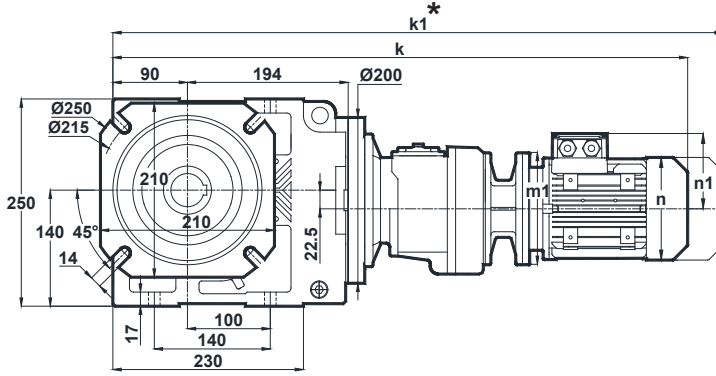

Klemens Pozisyonları  
Terminal Box Positions  
Klemmenkasten Positionen

	63/B5 63/B14	71/B5 71/B14
k	688	706
k1	749	797
n / n1	121 / 97	137 / 112
m1 (B5)	140	160
m1 (B14)	90	105

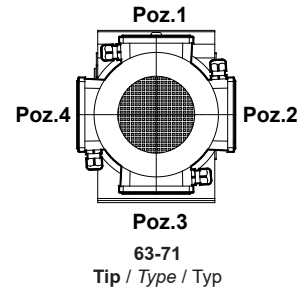

\* " k1 " Ölçüsü frenli redüktörlere aittir.  
Dimension " k1 " is for motors with brake.  
Maße " k1 " ist für Bremsenmotoren.

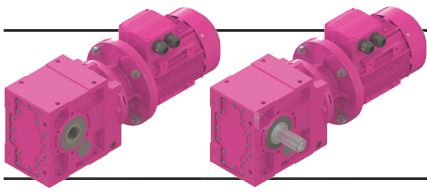

# Ölçü Sayfaları

## Dimension Pages

### Abmessungsseiten

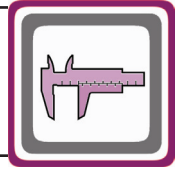

-Mil ucu çektirme deliği DIN 332 sayfa 2 / Tapped center hole to DIN 332, sheet 2 / Zentrierung mit Gewinde DIN 332, Blatt 2

#### KV473.00

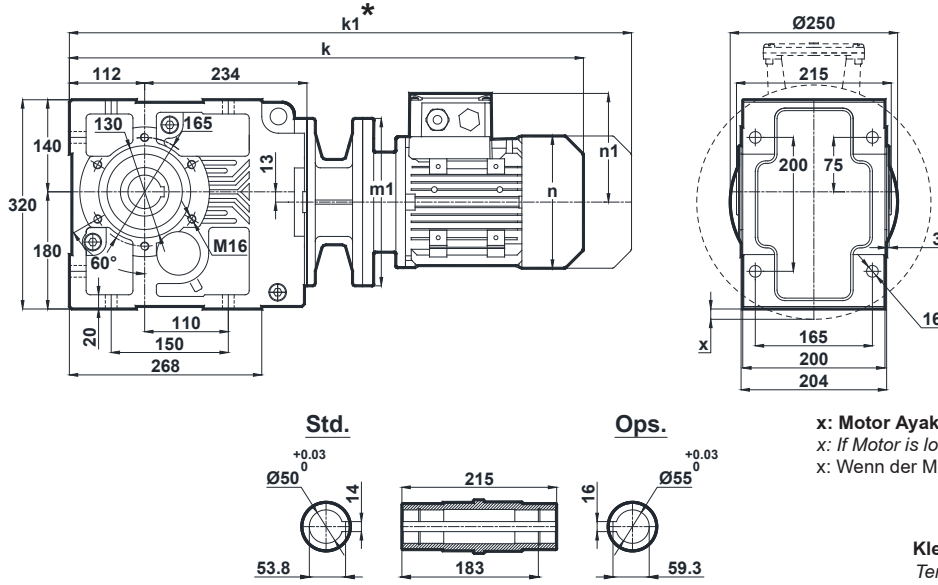

x: Motor Ayak bağlantı yüzeyinin altında ise  
x: If Motor is lower than foot mounting plane  
x: Wenn der Motor unter der Fußmontageebene ist

**Klemens Pozisyonları**  
Terminal Box Positions  
Klemmenkasten Positionen

	80/B5	90S/B5 90S/B14	90L/B5 90L/B14	100L/B5 100L/B14	112M/B5 112M/B14	132S/B5 132S/B14	132M/B5 132M/B14	160M/B5	160L/B5	180M/B5	180L/B5
k	637	678	678	732	752	855	855	1014	1014	1103	1103
k1	730	782.5	782.5	851.5	856.5	985	985	1194	1194	1273.5	1273.5
n / n1	155 / 121	176 / 132	176 / 132	193 / 147	215 / 158	257 / 179	257 / 179	315 / 219	315 / 219	347 / 234	347 / 234
m1 (B5)	200	200	200	250	250	300	300	350	350	350	350
m1 (B14)	-	140	140	160	160	200	200	-	-	-	-
x	-	-	-	-	-	-	-	8	8	8	8

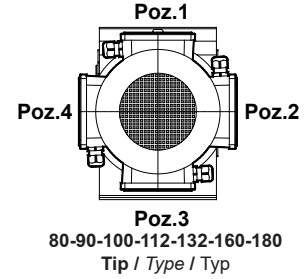

#### KV473.01

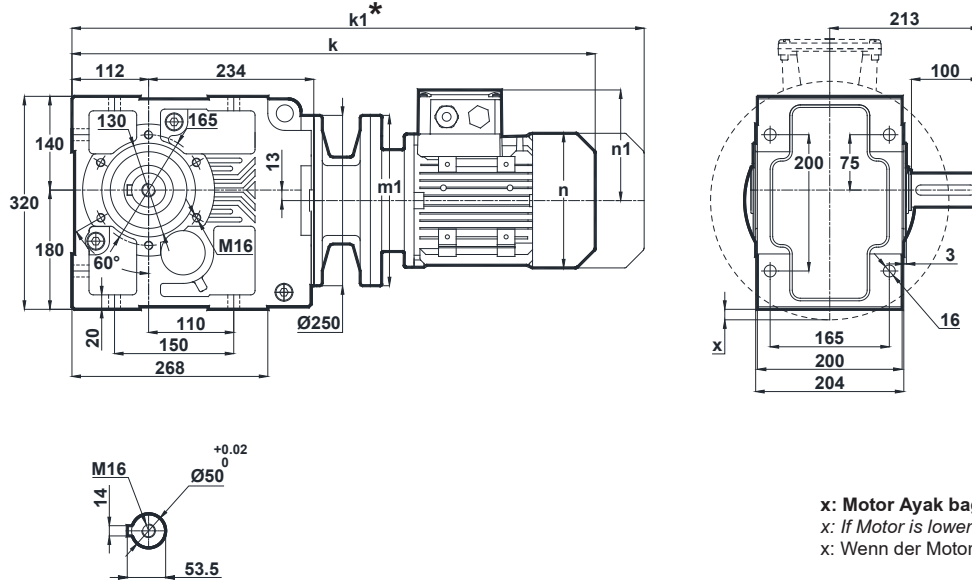

x: Motor Ayak bağlantı yüzeyinin altında ise  
x: If Motor is lower than foot mounting plane  
x: Wenn der Motor unter der Fußmontageebene ist

	80/B5	90S/B5 90S/B14	90L/B5 90L/B14	100L/B5 100L/B14	112M/B5 112M/B14	132S/B5 132S/B14	132M/B5 132M/B14	160M/B5	160L/B5	180M/B5	180L/B5
k	637	678	678	732	752	855	855	1014	1014	1103	1103
k1	730	782.5	782.5	851.5	856.5	985	985	1194	1194	1273.5	1273.5
n / n1	155 / 121	176 / 132	176 / 132	193 / 147	215 / 158	257 / 179	257 / 179	315 / 219	315 / 219	347 / 234	347 / 234
m1 (B5)	200	200	200	250	250	300	300	350	350	350	350
m1 (B14)	-	140	140	160	160	200	200	-	-	-	-
x	-	-	-	-	-	-	-	8	8	8	8

\* "k1" Ölçüsü frenli redüktörlere aittir.  
Dimension "k1" is for motors with brake.  
Maße "k1" ist für Bremsenmotoren.

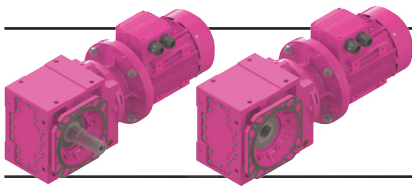

# Ölçü Sayfaları

## Dimension Pages

### Abmessungsseiten

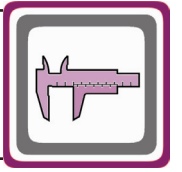

-Mil ucu çektirme deliği DIN 332 sayfa 2 / Tapped center hole to DIN 332, sheet 2 / Zentrierung mit Gewinde DIN 332, Blatt 2

#### KV473.02

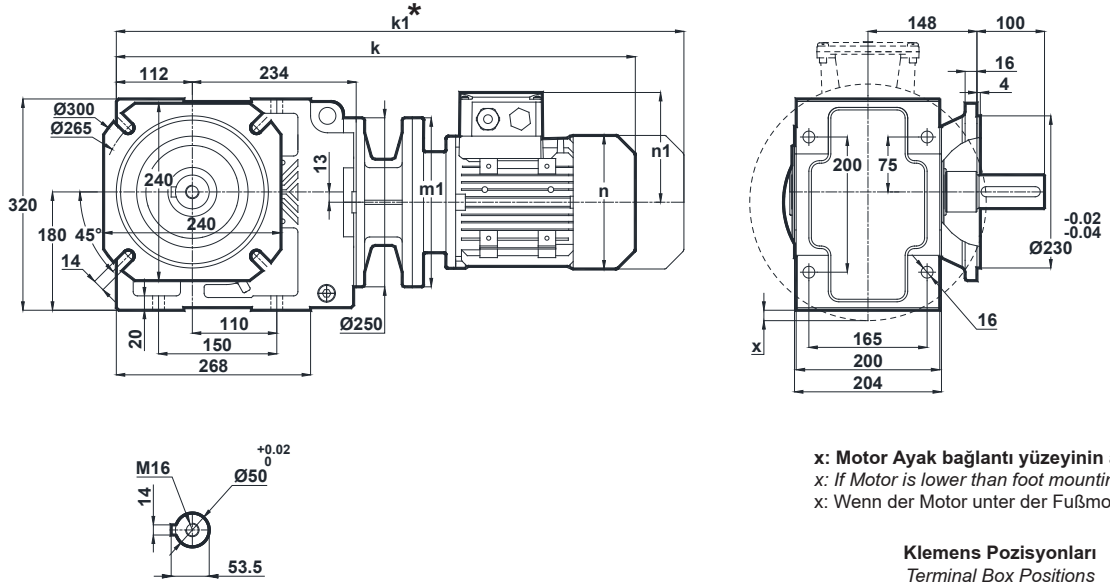

x: Motor Ayak bağlantı yüzeyinin altında ise  
x: If Motor is lower than foot mounting plane  
x: Wenn der Motor unter der Fußmontageebene ist

Klemens Pozisyonları  
Terminal Box Positions  
Klemmenkasten Positionen

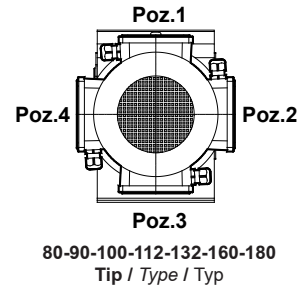

	80/B5	90S/B5 90S/B14	90L/B5 90L/B14	100L/B5 100L/B14	112M/B5 112M/B14	132S/B5 132S/B14	132M/B5 132M/B14	160M/B5	160L/B5	180M/B5	180L/B5
k	637	678	678	732	752	855	855	1014	1014	1103	1103
k1	730	782.5	782.5	851.5	856.5	985	985	1194	1194	1273.5	1273.5
n / n1	155 / 121	176 / 132	176 / 132	193 / 147	215 / 158	257 / 179	257 / 179	315 / 219	315 / 219	347 / 234	347 / 234
m1 (B5)	200	200	200	250	250	300	300	350	350	350	350
m1 (B14)	-	140	140	160	160	200	200	-	-	-	-
x	-	-	-	-	-	-	-	8	8	8	8

#### KV473.03

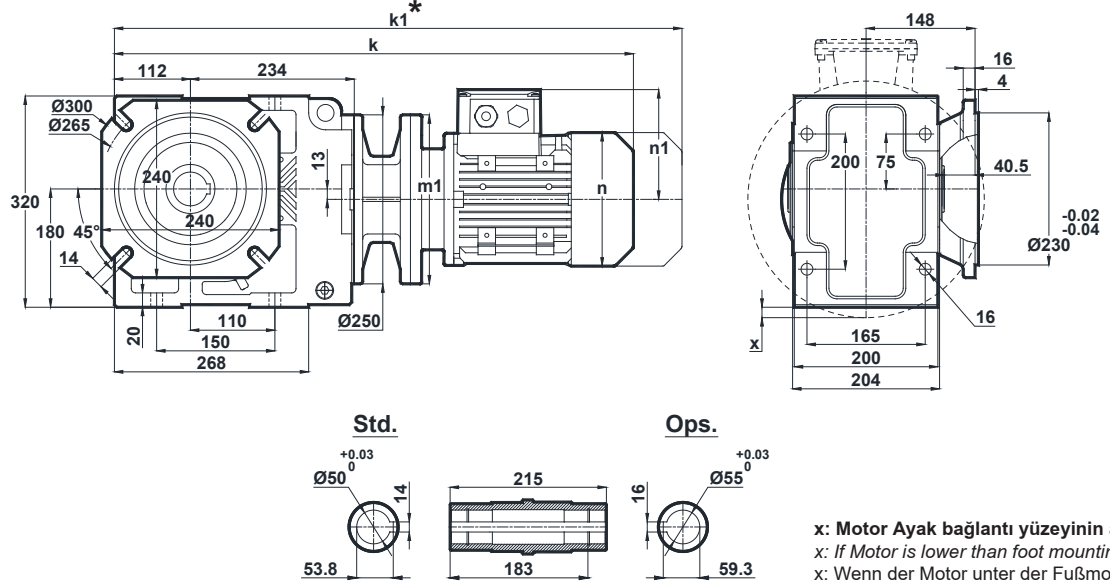

x: Motor Ayak bağlantı yüzeyinin altında ise  
x: If Motor is lower than foot mounting plane  
x: Wenn der Motor unter der Fußmontageebene ist

	80/B5	90S/B5 90S/B14	90L/B5 90L/B14	100L/B5 100L/B14	112M/B5 112M/B14	132S/B5 132S/B14	132M/B5 132M/B14	160M/B5	160L/B5	180M/B5	180L/B5
k	637	678	678	732	752	855	855	1014	1014	1103	1103
k1	730	782.5	782.5	851.5	856.5	985	985	1194	1194	1273.5	1273.5
n / n1	155 / 121	176 / 132	176 / 132	193 / 147	215 / 158	257 / 179	257 / 179	315 / 219	315 / 219	347 / 234	347 / 234
m1 (B5)	200	200	200	250	250	300	300	350	350	350	350
m1 (B14)	-	140	140	160	160	200	200	-	-	-	-
x	-	-	-	-	-	-	-	8	8	8	8

\* " k1 " Ölçüsü frenli redüktörlere aittir.  
Dimension " k1 " is for motors with brake.  
Maße " k1 " ist für Bremsenmotoren.

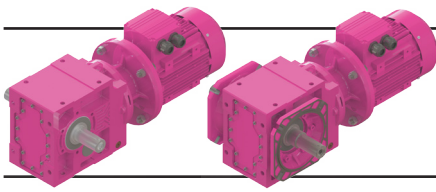

# Ölçü Sayfaları

## Dimension Pages

### Abmessungsseiten

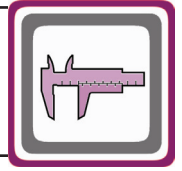

-Mil ucu çektirme deliği DIN 332 sayfa 2 / Tapped center hole to DIN 332, sheet 2 / Zentrierung mit Gewinde DIN 332, Blatt 2

#### KV473.04

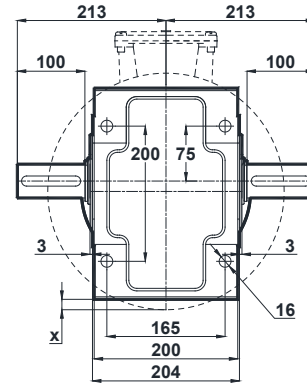
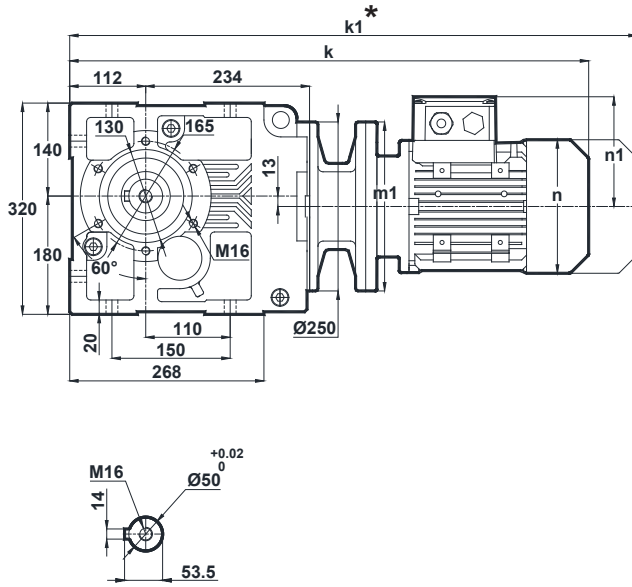

x: Motor Ayak bağlantı yüzeyinin altında ise  
x: If Motor is lower than foot mounting plane  
x: Wenn der Motor unter der Fußmontageebene ist

**Klemens Pozisyonları**  
Terminal Box Positions  
Klemmenkasten Positionen

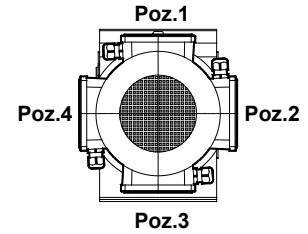

80-90-100-112-132-160-180  
Tip / Type / Typ

	80/B5	90S/B5 90S/B14	90L/B5 90L/B14	100L/B5 100L/B14	112M/B5 112M/B14	132S/B5 132S/B14	132M/B5 132M/B14	160M/B5	160L/B5	180M/B5	180L/B5
k	637	678	678	732	752	855	855	1014	1014	1103	1103
k1	730	782.5	782.5	851.5	856.5	985	985	1194	1194	1273.5	1273.5
n / n1	155 / 121	176 / 132	176 / 132	193 / 147	215 / 158	257 / 179	257 / 179	315 / 219	315 / 219	347 / 234	347 / 234
m1 (B5)	200	200	200	250	250	300	300	350	350	350	350
m1 (B14)	-	140	140	160	160	200	200	-	-	-	-
x	-	-	-	-	-	-	-	8	8	8	8

#### KV473.05

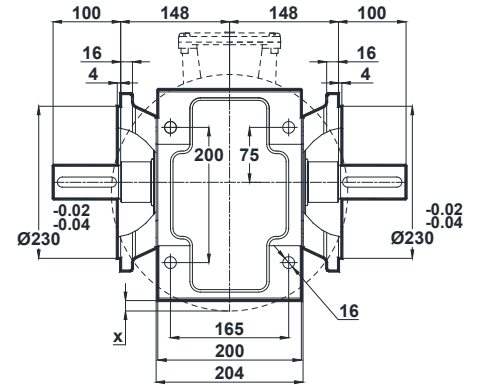
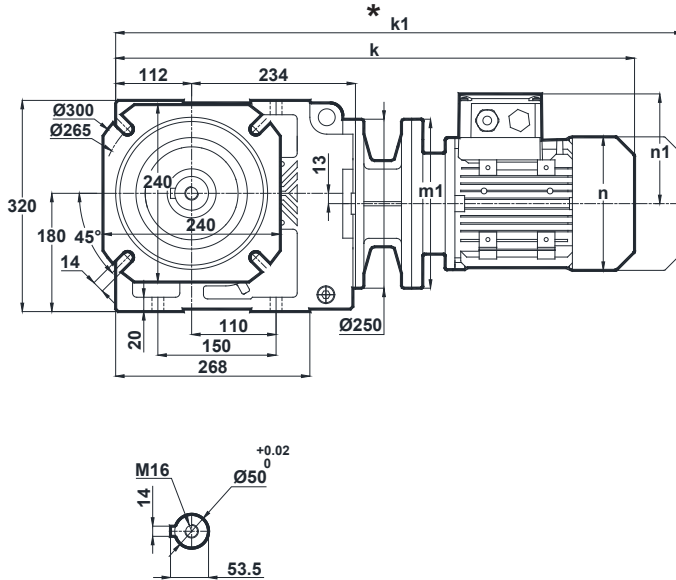

x: Motor Ayak bağlantı yüzeyinin altında ise  
x: If Motor is lower than foot mounting plane  
x: Wenn der Motor unter der Fußmontageebene ist

	80/B5	90S/B5 90S/B14	90L/B5 90L/B14	100L/B5 100L/B14	112M/B5 112M/B14	132S/B5 132S/B14	132M/B5 132M/B14	160M/B5	160L/B5	180M/B5	180L/B5
k	637	678	678	732	752	855	855	1014	1014	1103	1103
k1	730	782.5	782.5	851.5	856.5	985	985	1194	1194	1273.5	1273.5
n / n1	155 / 121	176 / 132	176 / 132	193 / 147	215 / 158	257 / 179	257 / 179	315 / 219	315 / 219	347 / 234	347 / 234
m1 (B5)	200	200	200	250	250	300	300	350	350	350	350
m1 (B14)	-	140	140	160	160	200	200	-	-	-	-
x	-	-	-	-	-	-	-	8	8	8	8

\* "k1" Ölçüsü frenli redüktörlere aittir.  
Dimension "k1" is for motors with brake.  
Maße "k1" ist für Bremsenmotoren.



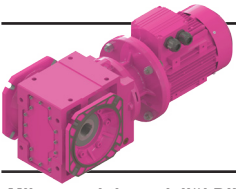

# Ölçü Sayfaları

## Dimension Pages

### Abmessungsseiten



-Mil ucu çekirme deliği DIN 332 sayfa 2 / Tapped center hole to DIN 332, sheet 2 / Zentrierung mit Gewinde DIN 332, Blatt 2

#### KV473.08

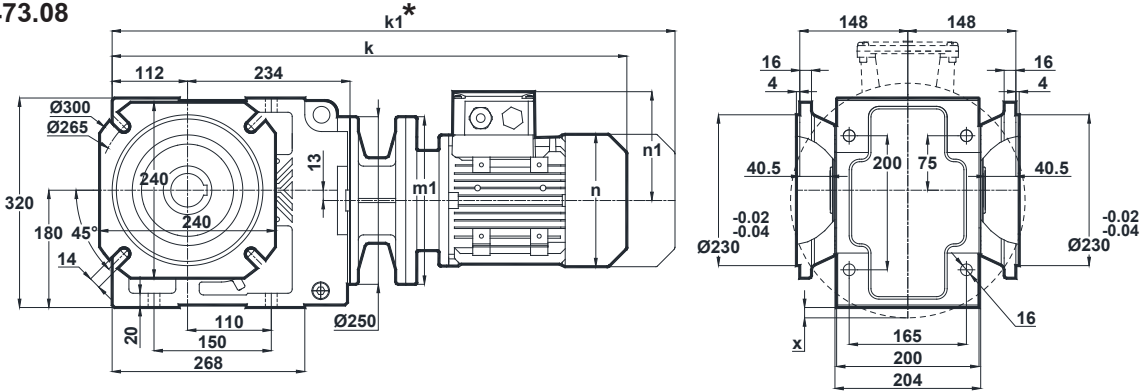

**Std.**

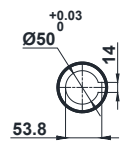

**Ops.**

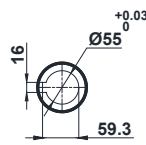

x: Motor Ayak bağlantı yüzeyinin altında ise  
x: If Motor is lower than foot mounting plane  
x: Wenn der Motor unter der Fußmontageebene ist

**Klemens Pozisyonları**  
Terminal Box Positions  
Klemmenkasten Positionen

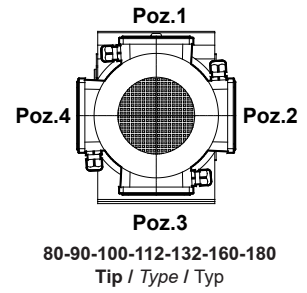

	80/B5	90S/B5 90S/B14	90L/B5 90L/B14	100L/B5 100L/B14	112M/B5 112M/B14	132S/B5 132S/B14	132M/B5 132M/B14	160M/B5	160L/B5	180M/B5	180L/B5
k	637	678	678	732	752	855	855	1014	1014	1103	1103
k1	730	782.5	782.5	851.5	856.5	985	985	1194	1194	1273.5	1273.5
n / n1	155 / 121	176 / 132	176 / 132	193 / 147	215 / 158	257 / 179	257 / 179	315 / 219	315 / 219	347 / 234	347 / 234
m1 (B5)	200	200	200	250	250	300	300	350	350	350	350
m1 (B14)	-	140	140	160	160	200	200	-	-	-	-
x	-	-	-	-	-	-	-	8	8	8	8

\* "k1" Ölçüsü frenli redüktörlere aittir.  
Dimension "k1" is for motors with brake.  
Maße "k1" ist für Bremsenmotoren.

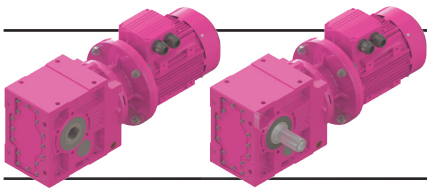

# Ölçü Sayfaları

## Dimension Pages

### Abmessungsseiten

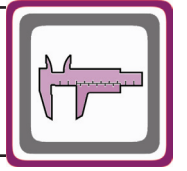

-Mil ucu çektirme deliği DIN 332 sayfa 2 / Tapped center hole to DIN 332, sheet 2 / Zentrierung mit Gewinde DIN 332, Blatt 2

#### KV474.00

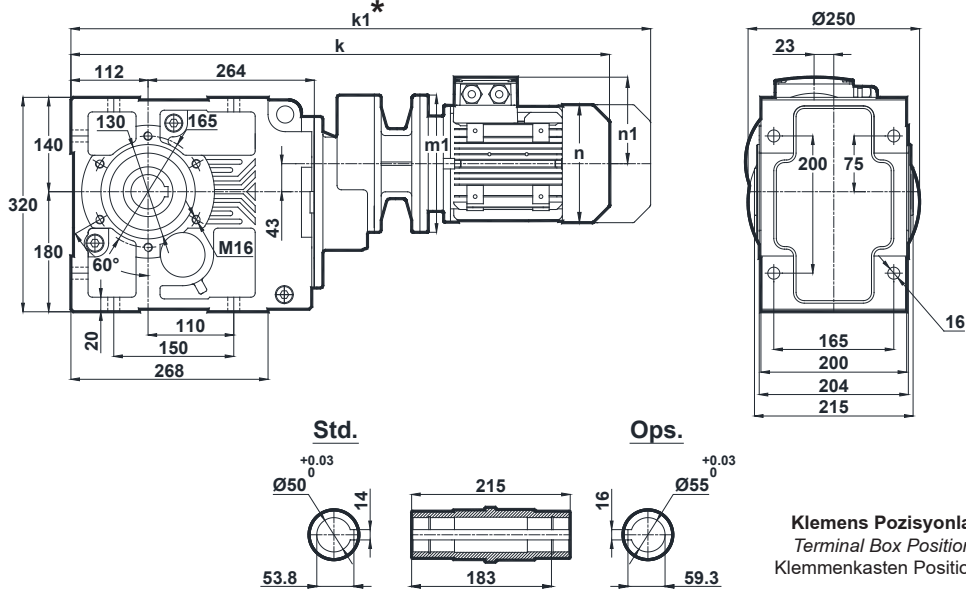

	71/B5	80/B5 80/B14
k	712	735
k1	803	828
n / n1	137	155
m1 (B5)	160	200
m1 (B14)	-	120

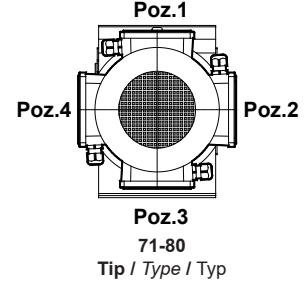

#### KV474.01

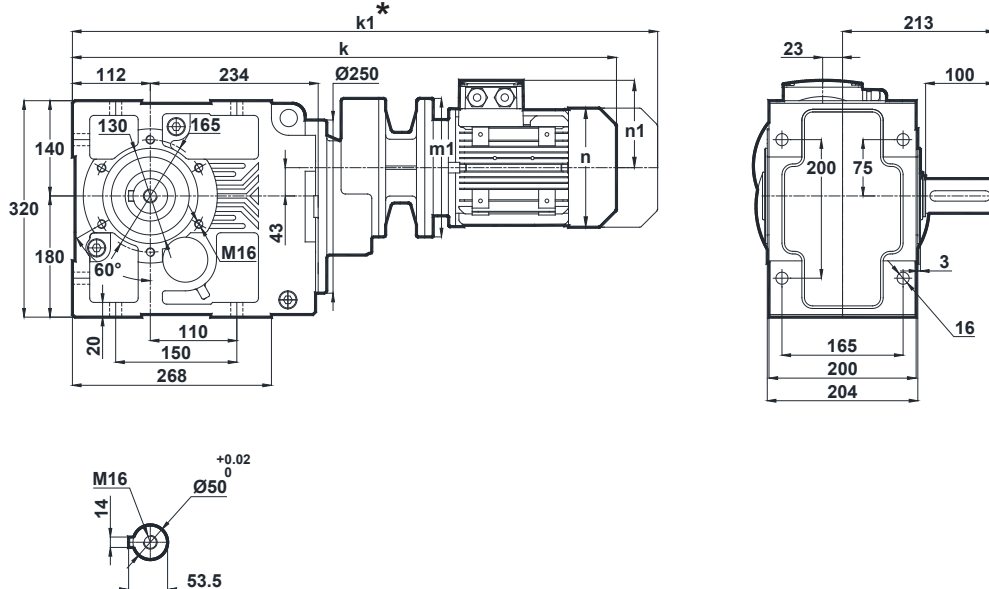

	71/B5	80/B5 80/B14
k	712	735
k1	803	828
n / n1	137	155
m1 (B5)	160	200
m1 (B14)	-	120

\* " k1 " Ölçüsü frenli redüktörlere aittir.  
Dimension " k1 " is for motors with brake.  
Maße " k1 " ist für Bremsmotoren.

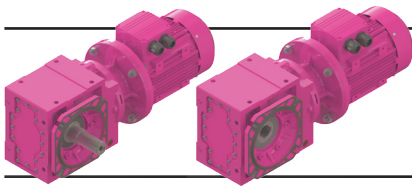

# Ölçü Sayfaları

## Dimension Pages

### Abmessungenseiten

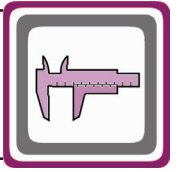

-Mil ucu çekirme deliği DIN 332 sayfa 2 / Tapped center hole to DIN 332, sheet 2 / Zentrierung mit Gewinde DIN 332, Blatt 2

#### KV474.02

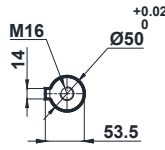
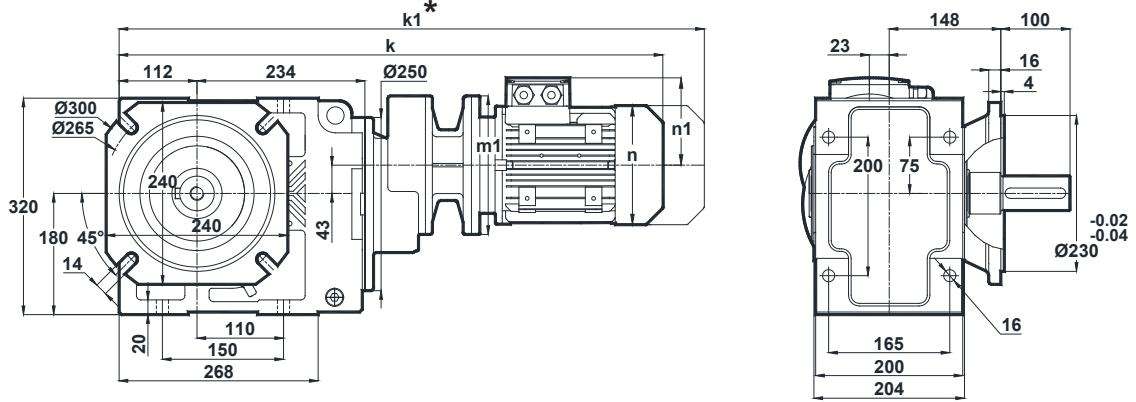

**Klemens Pozisyonları**  
Terminal Box Positions  
Klemmenkasten Positionen

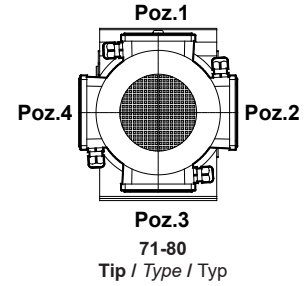

	71/B5	80/B5 80/B14
k	712	735
k1	803	828
n / n1	137	155
m1 (B5)	160	200
m1 (B14)	-	120

#### KV474.03

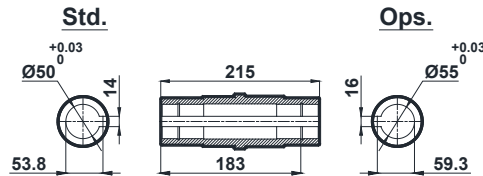
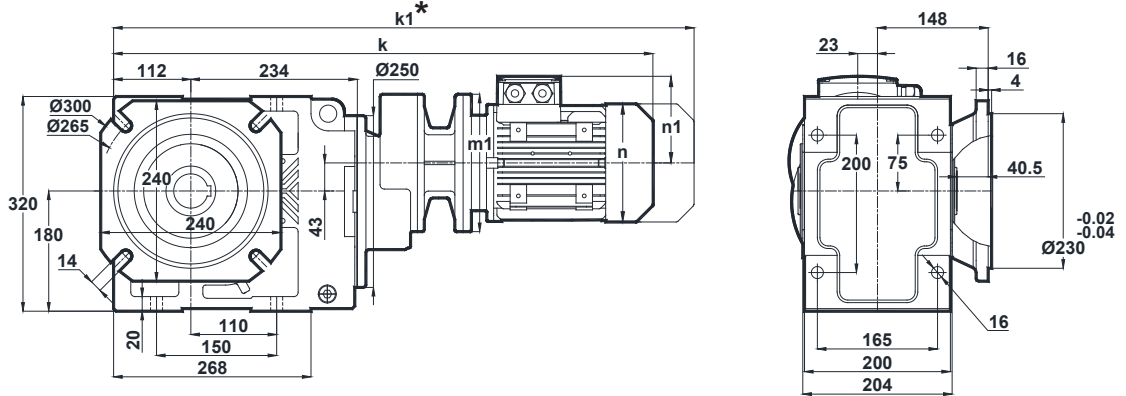

	71/B5	80/B5 80/B14
k	712	735
k1	803	828
n / n1	137	155
m1 (B5)	160	200
m1 (B14)	-	120

\* " k1 " Ölçüsü frenli redüktörlere aittir.  
Dimension " k1 " is for motors with brake.  
Maße " k1 " ist für Bremsenmotoren.

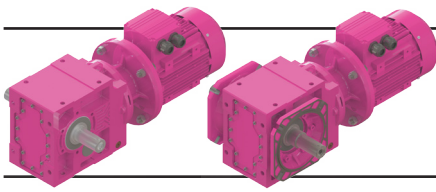

# Ölçü Sayfaları

## Dimension Pages

### Abmessungsseiten

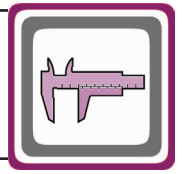

-Mil ucu çektirme deliği DIN 332 sayfa 2 / Tapped center hole to DIN 332, sheet 2 / Zentrierung mit Gewinde DIN 332, Blatt 2

#### KV474.04

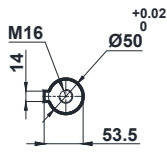
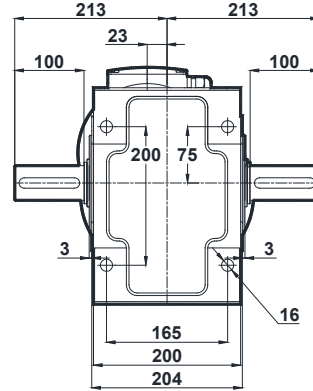
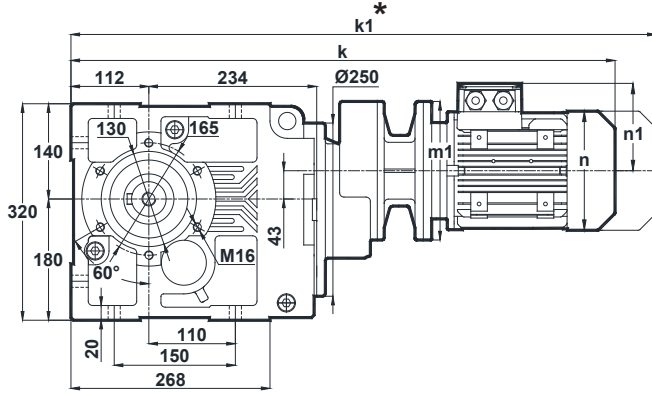

	71/B5	80/B5 80/B14
k	712	735
k1	803	828
n / n1	137	155
m1 (B5)	160	200
m1 (B14)	-	120

**Klemens Pozisyonları**  
Terminal Box Positions  
Klemmenkasten Positionen

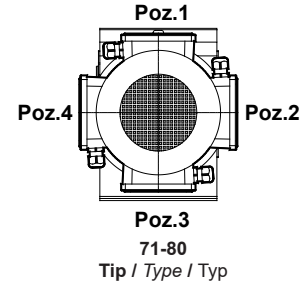

#### KV474.05

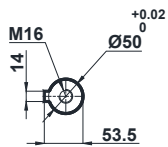
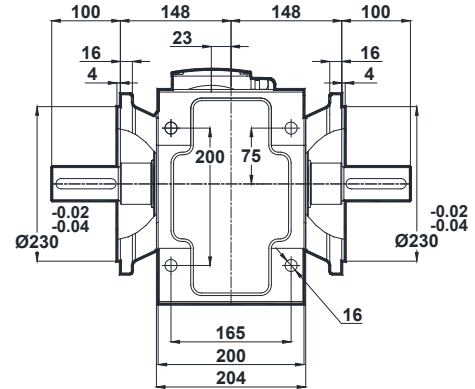
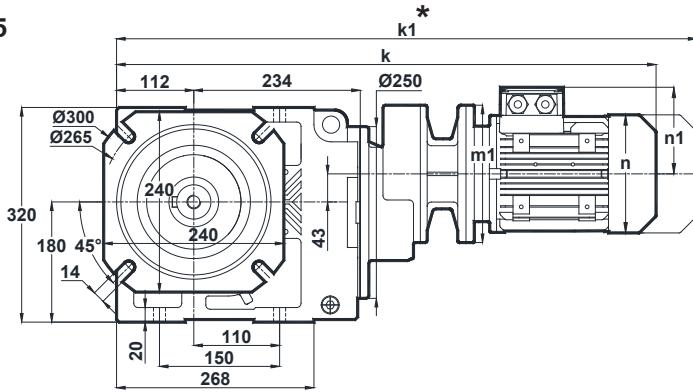

	71/B5	80/B5 80/B14
k	712	735
k1	803	828
n / n1	137	155
m1 (B5)	160	200
m1 (B14)	-	120

\* " k1 " Ölçüsü frenli redüktörlere aittir.  
Dimension " k1 " is for motors with brake.  
Maße " k1 " ist für Bremsenmotoren.

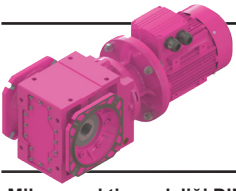

# Ölçü Sayfaları Dimension Pages Abmessungsseiten

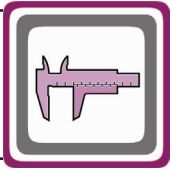

-Mil ucu çektirme deliği DIN 332 sayfa 2 / Tapped center hole to DIN 332, sheet 2 / Zentrierung mit Gewinde DIN 332, Blatt 2

KV474.08

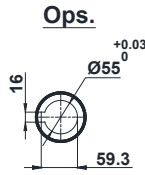
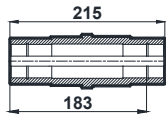
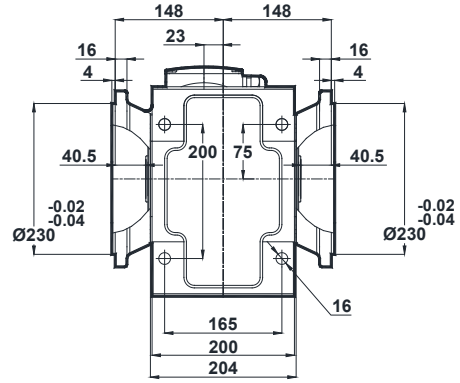
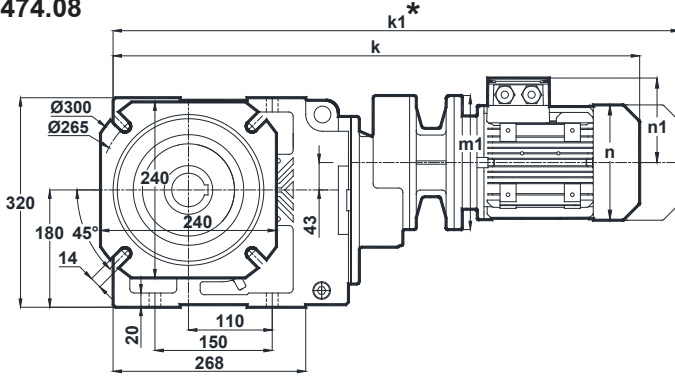

**Klemens Pozisyonları**  
Terminal Box Positions  
Klemmenkasten Positionen

	71/B5	80/B5 80/B14
k	712	735
k1	803	828
n / n1	137	155
m1 (B5)	160	200
m1 (B14)	-	120

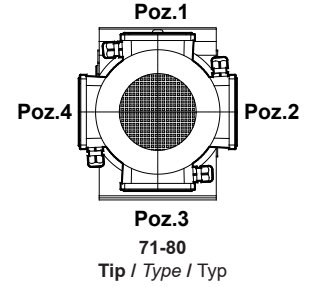

\* " k1 " Ölçüsü frenli redüktörlere aittir.  
Dimension " k1 " is for motors with brake.  
Maße " k1 " ist für Bremsenmotoren.

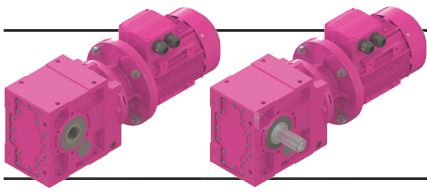

# Ölçü Sayfaları

## Dimension Pages

### Abmessungsseiten

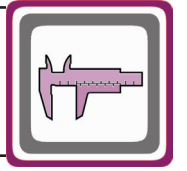

-Mil ucu çektirme deliği DIN 332 sayfa 2 / Tapped center hole to DIN 332, sheet 2 / Zentrierung mit Gewinde DIN 332, Blatt 2

KV475.00  
KV476.00

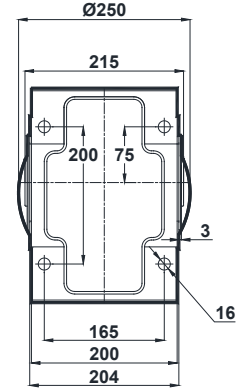
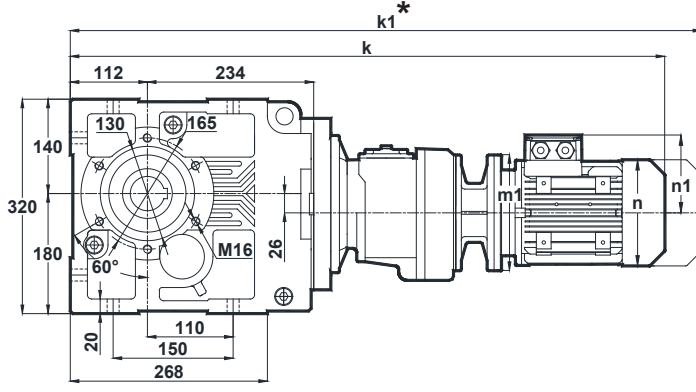

Std.

Ops.

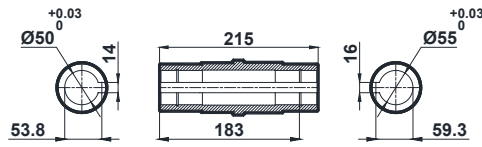

**Klemens Pozisyonları**  
Terminal Box Positions  
Klemmenkasten Positionen

	63/B5	71/B5 71/B14
k	822	811
k1	883	902
n / n1	121 / 97	137 / 112
m1 (B5)	140	160
m1 (B14)	-	105

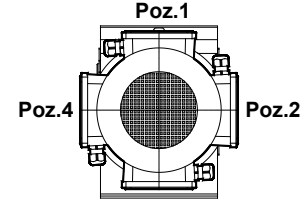

Poz.3

63-71

Tip / Type / Typ

KV475.01  
KV476.01

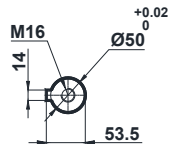
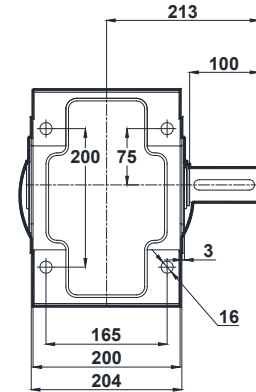
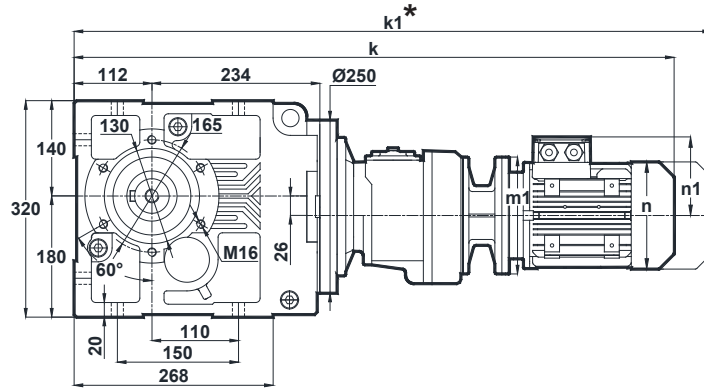

	63/B5	71/B5 71/B14
k	822	811
k1	883	902
n / n1	121 / 97	137 / 112
m1 (B5)	140	160
m1 (B14)	-	105

\* " k1 " Ölçüsü frenli redüktörlere aittir.  
Dimension " k1 " is for motors with brake.  
Maße " k1 " ist für Bremsenmotoren.

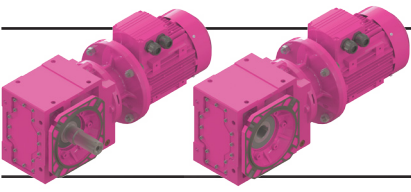

# Ölçü Sayfaları

## Dimension Pages

### Abmessungsseiten

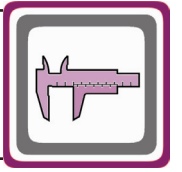

-Mil ucu çekirme deliği DIN 332 sayfa 2 / Tapped center hole to DIN 332, sheet 2 / Zentrierung mit Gewinde DIN 332, Blatt 2

KV475.02  
KV476.02

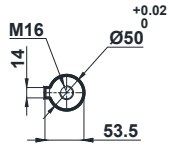
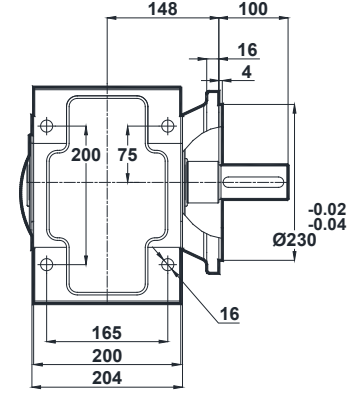
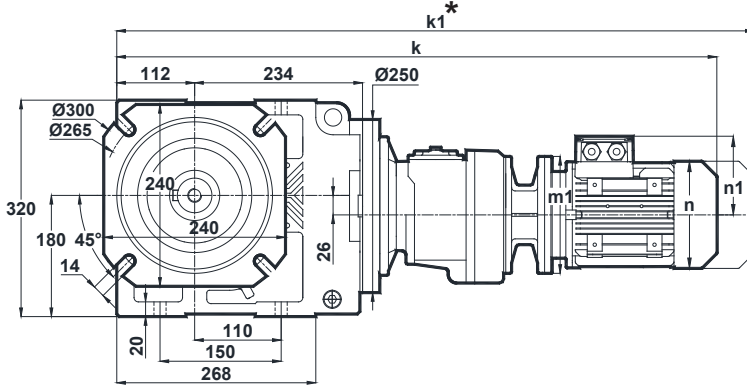

	63/B5	71/B5 71/B14
k	822	811
k1	883	902
n / n1	121 / 97	137 / 112
m1 (B5)	140	160
m1 (B14)	-	105

Klemens Pozisyonları  
Terminal Box Positions  
Klemmenkasten Positionen

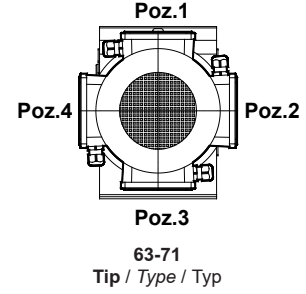

KV475.03  
KV476.03

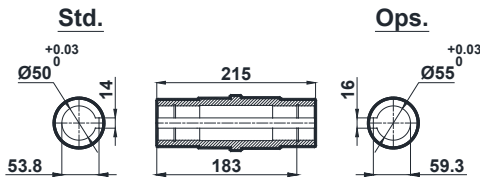
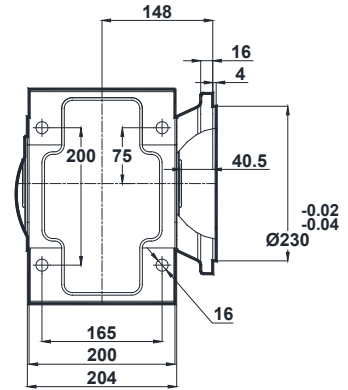
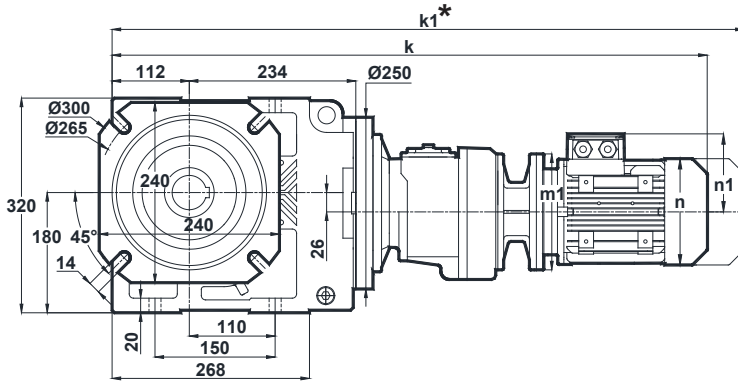

	63/B5	71/B5 71/B14
k	822	811
k1	883	902
n / n1	121 / 97	137 / 112
m1 (B5)	140	160
m1 (B14)	-	105

\* " k1 " Ölçüsü frenli redüktörlere aittir.  
Dimension " k1 " is for motors with brake.  
Maße " k1 " ist für Bremsenmotoren.

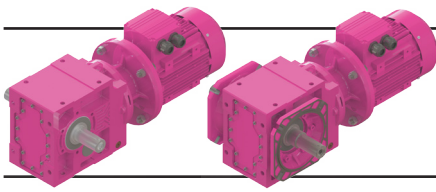

# Ölçü Sayfaları

## Dimension Pages

### Abmessungsseiten

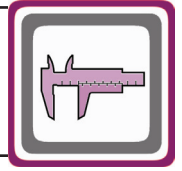

-Mil ucu çektirme deliği DIN 332 sayfa 2 / Tapped center hole to DIN 332, sheet 2 / Zentrierung mit Gewinde DIN 332, Blatt 2

KV475.04  
KV476.04

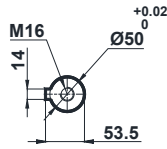
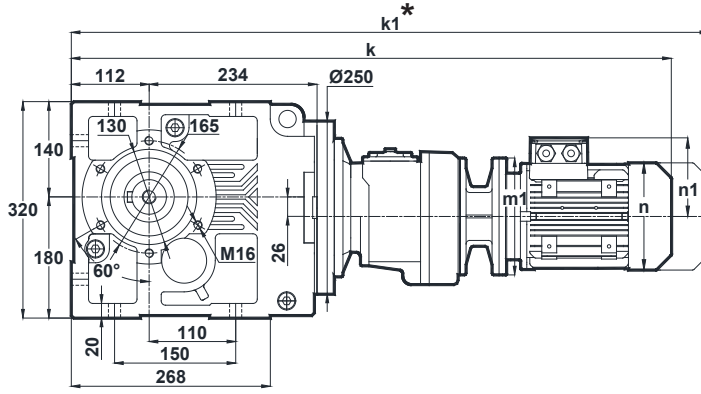

	63/B5	71/B5 71/B14
k	822	811
k1	883	902
n / n1	121 / 97	137 / 112
m1 (B5)	140	160
m1 (B14)	-	105

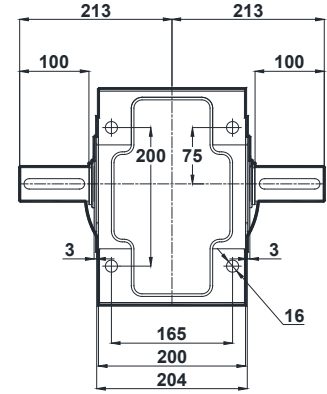

Klemens Pozisyonları  
Terminal Box Positions  
Klemmenkasten Positionen

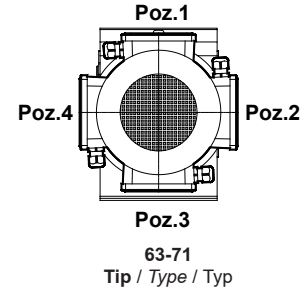

KV475.05  
KV476.05

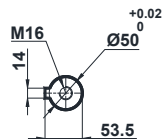
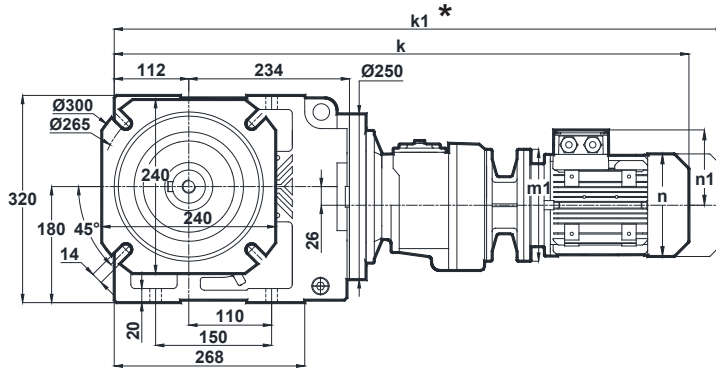

	63/B5	71/B5 71/B14
k	822	811
k1	883	902
n / n1	121 / 97	137 / 112
m1 (B5)	140	160
m1 (B14)	-	105

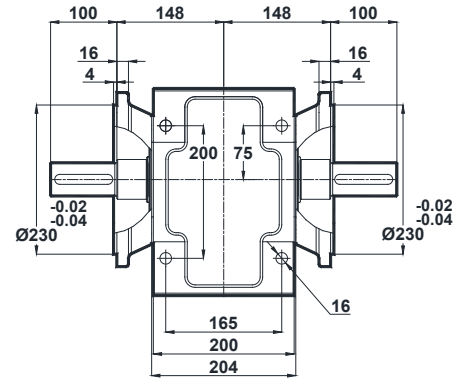

\* " k1 " Ölçüsü frenli redüktörlere aittir.  
Dimension " k1 " is for motors with brake.  
Maße " k1 " ist für Bremsmotoren.



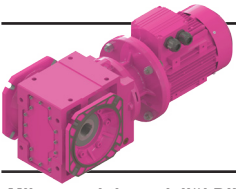

# Ölçü Sayfaları Dimension Pages Abmessungenseiten



-Mil ucu çekirme deliği DIN 332 sayfa 2 / Tapped center hole to DIN 332, sheet 2 / Zentrierung mit Gewinde DIN 332, Blatt 2

KV475.08  
KV476.08

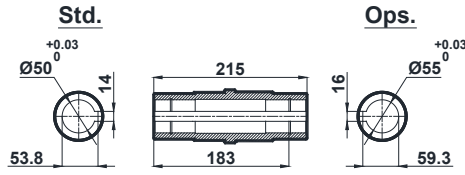
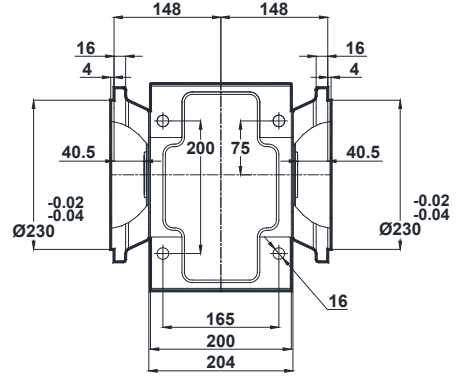
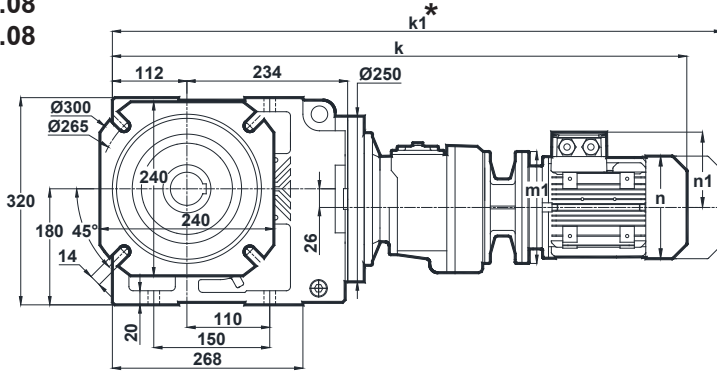

Klemens Pozisyonları  
Terminal Box Positions  
Klemmenkasten Positionen

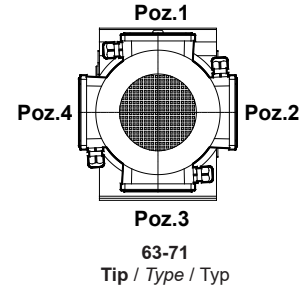

	63/B5	71/B5 71/B14
k	822	811
k1	883	902
n / n1	121 / 97	137 / 112
m1 (B5)	140	160
m1 (B14)	-	105

\* " k1 " Ölçüsü frenli redüktörlere aittir.  
Dimension " k1 " is for motors with brake.  
Maße " k1 " ist für Bremsenmotoren.

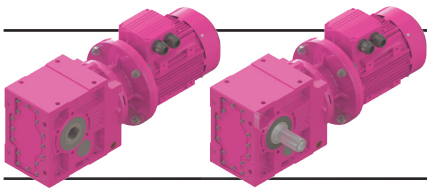

# Ölçü Sayfaları

## Dimension Pages

### Abmessungsseiten

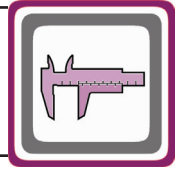

-Mil ucu çektirme deliği DIN 332 sayfa 2 / Tapped center hole to DIN 332, sheet 2 / Zentrierung mit Gewinde DIN 332, Blatt 2

#### KV573.00

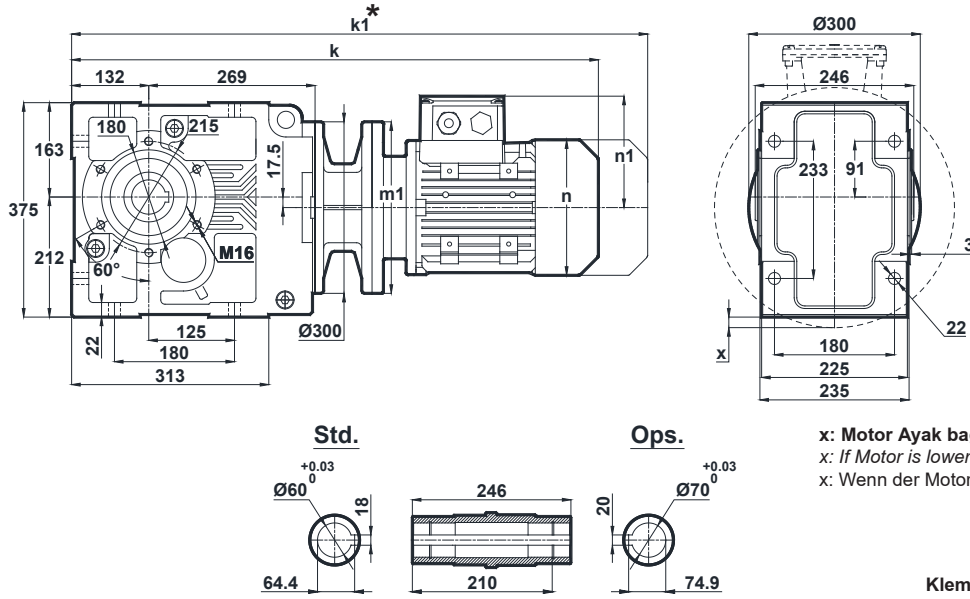

x: Motor Ayak bağlantı yüzeyinin altında ise  
x: If Motor is lower than foot mounting plane  
x: Wenn der Motor unter der Fußmontageebene ist

Klemens Pozisyonları  
Terminal Box Positions  
Klemmenkasten Positionen

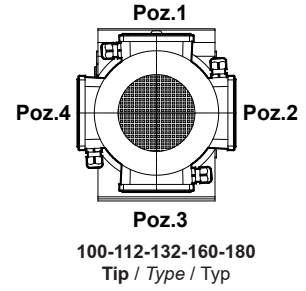

	100L/B5	112M/B5	132S/B5 132S/B14	132M/B5 132M/B14	160M/B5	160L/B5	180M/B5	180L/B5
k	784	805	910	910	1065	1065	1154	1154
k1	903.5	909.5	1040	1040	1245	1245	1324.5	1324.5
n / n1	193 / 147	215 / 158	257 / 179	257 / 179	315 / 219	315 / 219	347 / 234	347 / 234
m1 (B5)	250	250	300	300	350	350	350	400
m1 (B14)	-	-	200	200	-	-	-	-
x	-	-	-	-	-	-	-	5,5

#### KV573.01

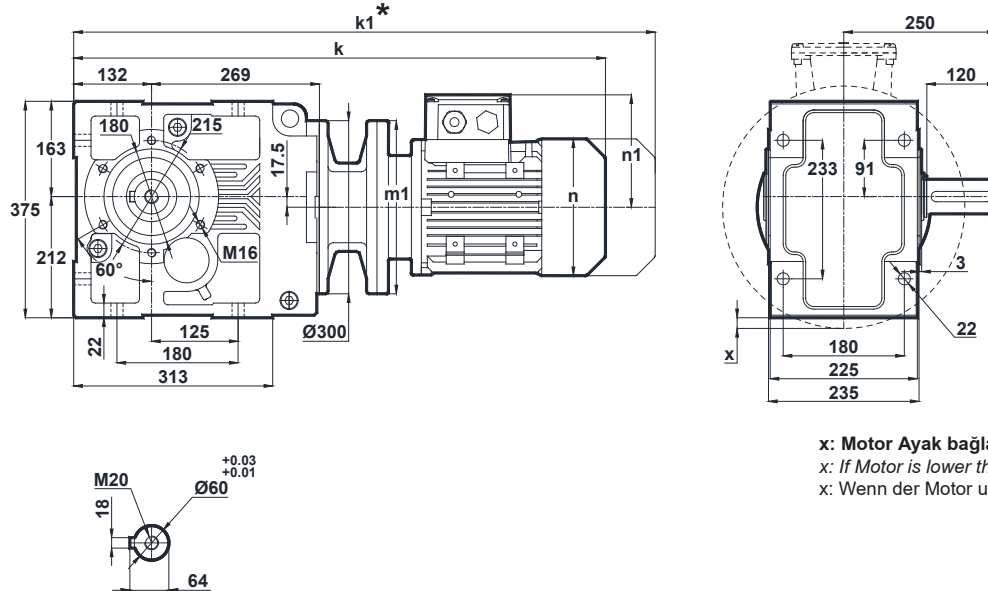

x: Motor Ayak bağlantı yüzeyinin altında ise  
x: If Motor is lower than foot mounting plane  
x: Wenn der Motor unter der Fußmontageebene ist

	100L/B5	112M/B5	132S/B5 132S/B14	132M/B5 132M/B14	160M/B5	160L/B5	180M/B5	180L/B5
k	784	805	910	910	1065	1065	1154	1154
k1	903.5	909.5	1040	1040	1245	1245	1324.5	1324.5
n / n1	193 / 147	215 / 158	257 / 179	257 / 179	315 / 219	315 / 219	347 / 234	347 / 234
m1 (B5)	250	250	300	300	350	350	350	400
m1 (B14)	-	-	200	200	-	-	-	-
x	-	-	-	-	-	-	-	5,5

\* " k1 " Ölçüsü frenli redüktörlere aittir.  
Dimension " k1 " is for motors with brake.  
Maße " k1 " ist für Bremsenmotoren.

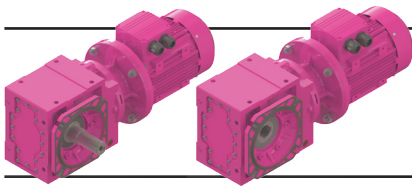

# Ölçü Sayfaları

## Dimension Pages

### Abmessungsseiten



-Mil ucu çektirme deliği DIN 332 sayfa 2 / Tapped center hole to DIN 332, sheet 2 / Zentrierung mit Gewinde DIN 332, Blatt 2

#### KV573.02

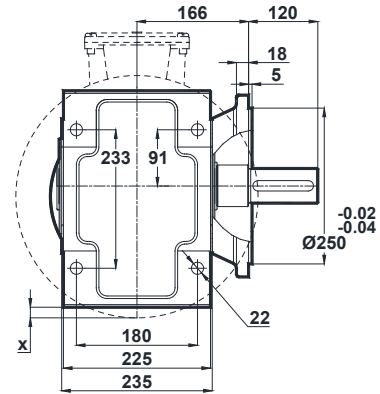
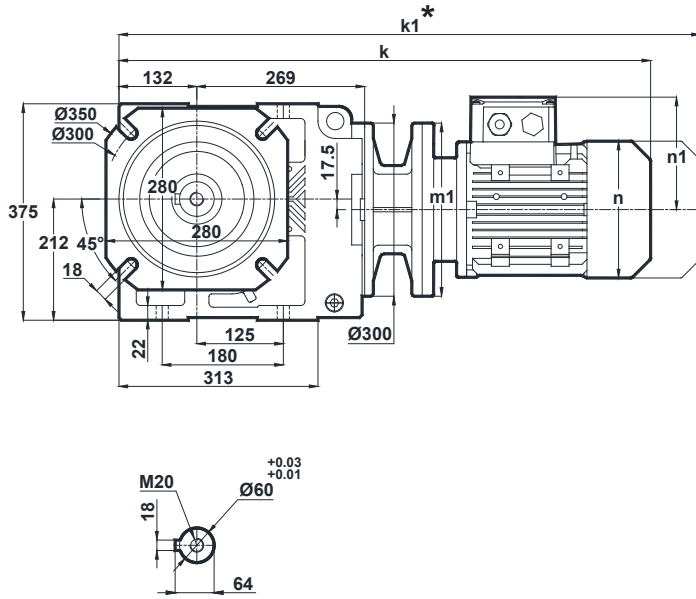

x: Motor Ayak bağlantı yüzeyinin altında ise  
x: If Motor is lower than foot mounting plane  
x: Wenn der Motor unter der Fußmontageebene ist

Klemens Pozisyonları  
Terminal Box Positions  
Klemmenkasten Positionen

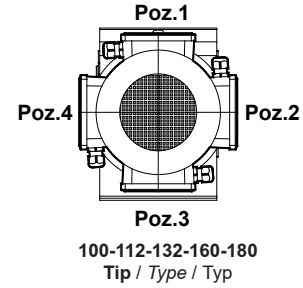

	100L/B5	112M/B5	132S/B5 132S/B14	132M/B5 132M/B14	160M/B5	160L/B5	180M/B5	180L/B5
k	784	805	910	910	1065	1065	1154	1154
k1	903.5	909.5	1040	1040	1245	1245	1324.5	1324.5
n / n1	193 / 147	215 / 158	257 / 179	257 / 179	315 / 219	315 / 219	347 / 234	347 / 234
m1 (B5)	250	250	300	300	350	350	350	400
m1 (B14)	-	-	200	200	-	-	-	-
x	-	-	-	-	-	-	-	5,5

#### KV573.03

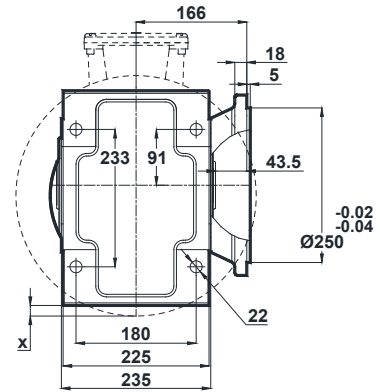
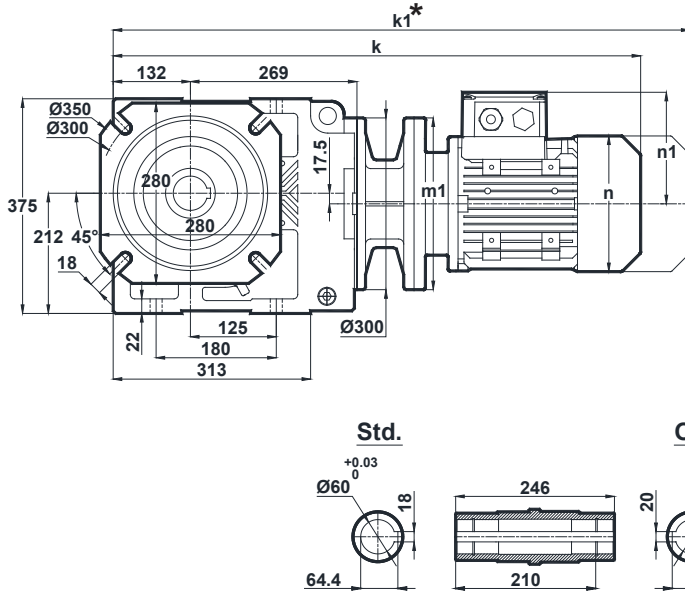

x: Motor Ayak bağlantı yüzeyinin altında ise  
x: If Motor is lower than foot mounting plane  
x: Wenn der Motor unter der Fußmontageebene ist

	100L/B5	112M/B5	132S/B5 132S/B14	132M/B5 132M/B14	160M/B5	160L/B5	180M/B5	180L/B5
k	784	805	910	910	1065	1065	1154	1154
k1	903.5	909.5	1040	1040	1245	1245	1324.5	1324.5
n / n1	193 / 147	215 / 158	257 / 179	257 / 179	315 / 219	315 / 219	347 / 234	347 / 234
m1 (B5)	250	250	300	300	350	350	350	400
m1 (B14)	-	-	200	200	-	-	-	-
x	-	-	-	-	-	-	-	5,5

\* " k1 " Ölçüsü frenli redüktörlere aittir.  
Dimension " k1 " is for motors with brake.  
Maße " k1 " ist für Bremsenmotoren.

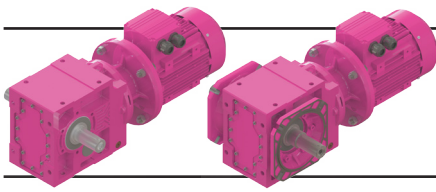

# Ölçü Sayfaları

## Dimension Pages

### Abmessungsseiten

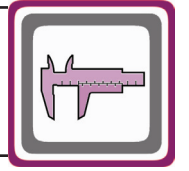

-Mil ucu çekirme deliği DIN 332 sayfa 2 / Tapped center hole to DIN 332, sheet 2 / Zentrierung mit Gewinde DIN 332, Blatt 2

#### KV573.04

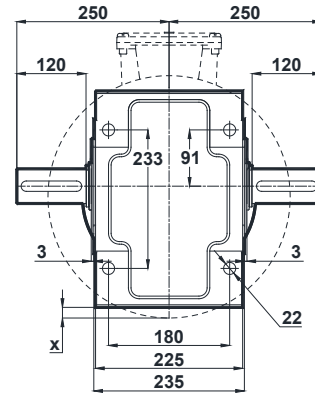
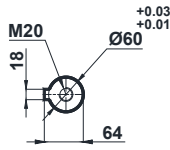
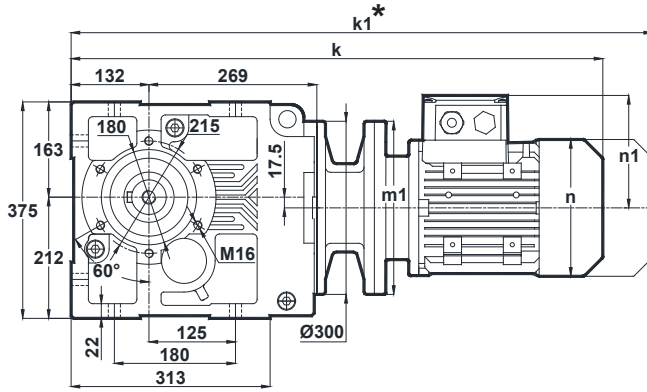

x: Motor Ayak bağlantı yüzeyinin altında ise  
x: If Motor is lower than foot mounting plane  
x: Wenn der Motor unter der Fußmontageebene ist

Klemens Pozisyonları  
Terminal Box Positions  
Klemmenkasten Positionen

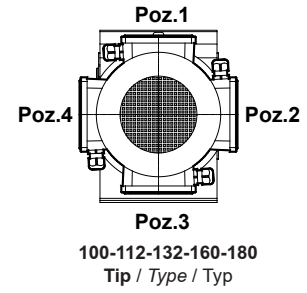

	100L/B5	112M/B5	132S/B5 132S/B14	132M/B5 132M/B14	160M/B5	160L/B5	180M/B5	180L/B5
k	784	805	910	910	1065	1065	1154	1154
k1	903.5	909.5	1040	1040	1245	1245	1324.5	1324.5
n / n1	193 / 147	215 / 158	257 / 179	257 / 179	315 / 219	315 / 219	347 / 234	347 / 234
m1 (B5)	250	250	300	300	350	350	350	400
m1 (B14)	-	-	200	200	-	-	-	-
x	-	-	-	-	-	-	-	5,5

#### KV573.05

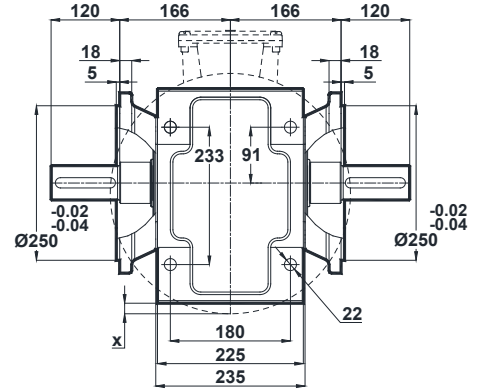
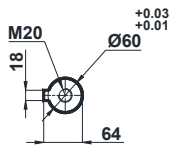
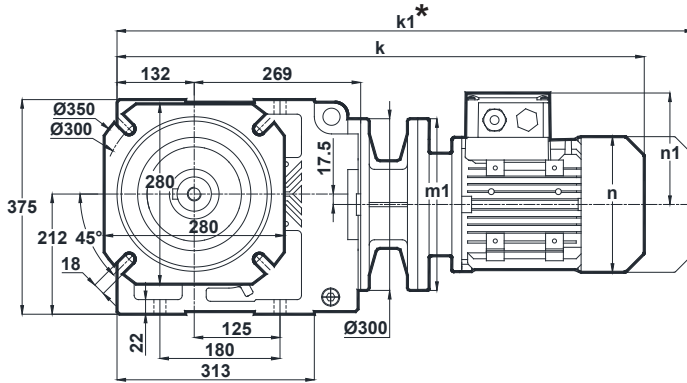

x: Motor Ayak bağlantı yüzeyinin altında ise  
x: If Motor is lower than foot mounting plane  
x: Wenn der Motor unter der Fußmontageebene ist

	100L/B5	112M/B5	132S/B5 132S/B14	132M/B5 132M/B14	160M/B5	160L/B5	180M/B5	180L/B5
k	784	805	910	910	1065	1065	1154	1154
k1	903.5	909.5	1040	1040	1245	1245	1324.5	1324.5
n / n1	193 / 147	215 / 158	257 / 179	257 / 179	315 / 219	315 / 219	347 / 234	347 / 234
m1 (B5)	250	250	300	300	350	350	350	400
m1 (B14)	-	-	200	200	-	-	-	-
x	-	-	-	-	-	-	-	5,5

\* " k1 " Ölçüsü frenli redüktörlere aittir.  
Dimension " k1 " is for motors with brake.  
Maße " k1 " ist für Bremsmotoren.

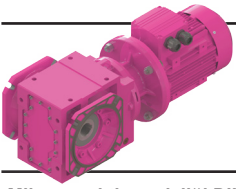

# Ölçü Sayfaları Dimension Pages Abmessungsseiten

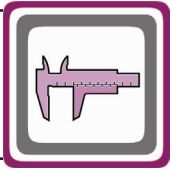

-Mil ucu çektirme deliği DIN 332 sayfa 2 / Tapped center hole to DIN 332, sheet 2 / Zentrierung mit Gewinde DIN 332, Blatt 2

KV573.08

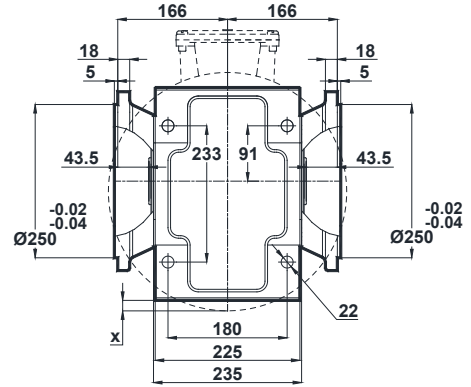
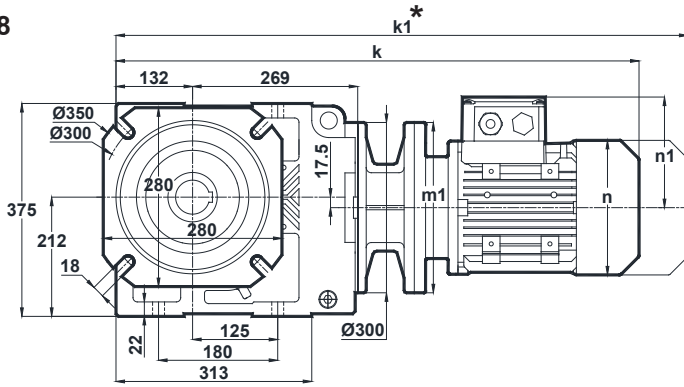

Std.

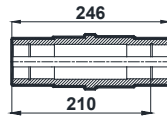
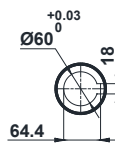

Ops.

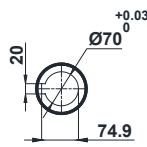

x: Motor Ayak bağlantı yüzeyinin altında ise  
x: If Motor is lower than foot mounting plane  
x: Wenn der Motor unter der Fußmontageebene ist

Klemens Pozisyonları  
Terminal Box Positions  
Klemmenkasten Positionen

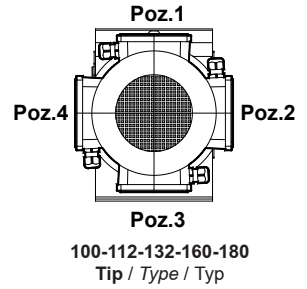

	100L/B5	112M/B5	132S/B5 132S/B14	132M/B5 132M/B14	160M/B5	160L/B5	180M/B5	180L/B5
k	784	805	910	910	1065	1065	1154	1154
k1	903.5	909.5	1040	1040	1245	1245	1324.5	1324.5
n / n1	193 / 147	215 / 158	257 / 179	257 / 179	315 / 219	315 / 219	347 / 234	347 / 234
m1 (B5)	250	250	300	300	350	350	350	400
m1 (B14)	-	-	200	200	-	-	-	-
x	-	-	-	-	-	-	-	5,5

\* " k1 " Ölçüsü frenli redüktörlere aittir.  
Dimension " k1 " is for motors with brake.  
Maße " k1 " ist für Bremsenmotoren.

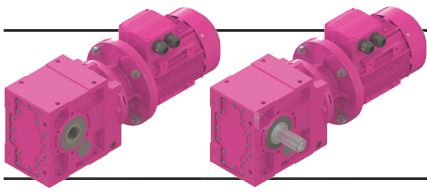

# Ölçü Sayfaları Dimension Pages Abmessungsseiten

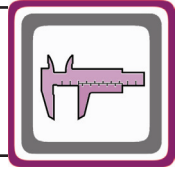

-Mil ucu çektirme deliği DIN 332 sayfa 2 / Tapped center hole to DIN 332, sheet 2 / Zentrierung mit Gewinde DIN 332, Blatt 2

## KV574.00

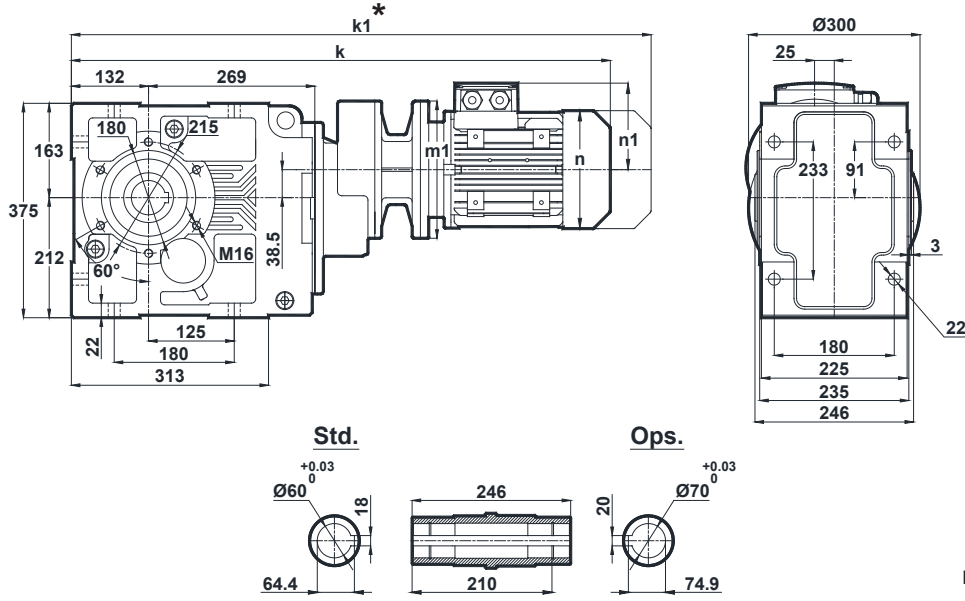

	71/B5	80/B5 80/B14	90S/B5 90S/B14	90L/B5 90L/B14	100L/B5
k	765	788	829	829	881
k1	856	881	933.5	933.5	1000.5
n / n1	137 / 112	155 / 121	176 / 132	176 / 132	193 / 147
m1 (B5)	160	200	200	200	250
m1 (B14)	-	120	140	140	160

Klemens Pozisyonları  
Terminal Box Positions  
Klemmenkasten Positionen

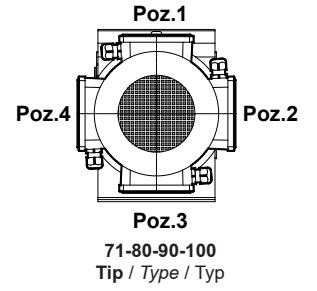

## KV574.01

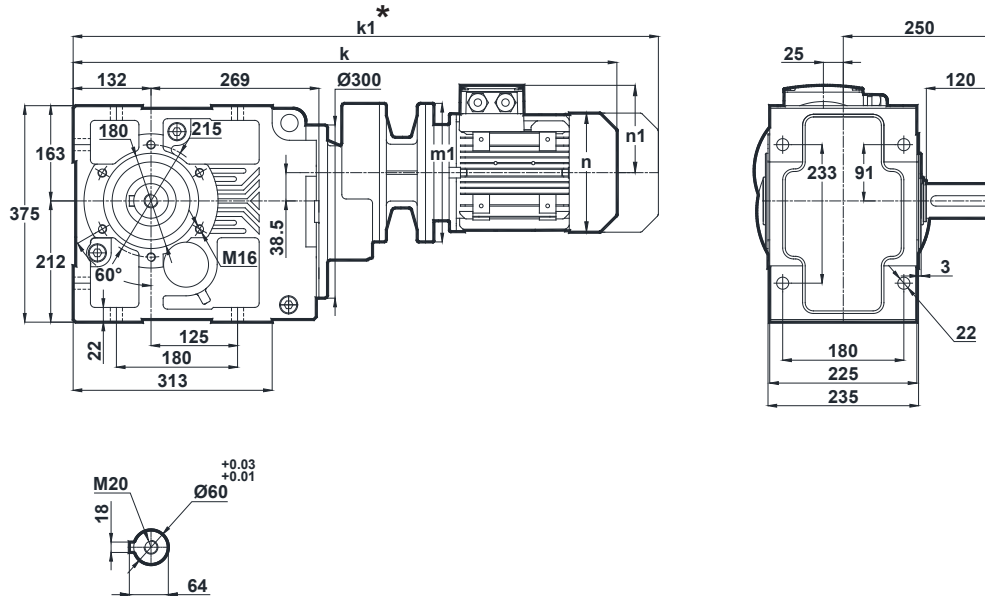

	71/B5	80/B5 80/B14	90S/B5 90S/B14	90L/B5 90L/B14	100L/B5
k	765	788	829	829	881
k1	856	881	933.5	933.5	1000.5
n / n1	137 / 112	155 / 121	176 / 132	176 / 132	193 / 147
m1 (B5)	160	200	200	200	250
m1 (B14)	-	120	140	140	160

\* "k1" Ölçüsü frenli redüktörlere aittir.  
Dimension "k1" is for motors with brake.  
Maße "k1" ist für Bremsenmotoren.

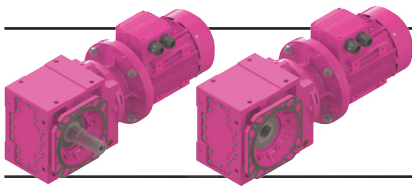

# Ölçü Sayfaları

## Dimension Pages

### Abmessungsseiten

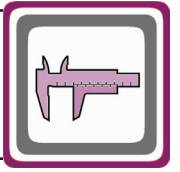

-Mil ucu çektirme deliği DIN 332 sayfa 2 / Tapped center hole to DIN 332, sheet 2 / Zentrierung mit Gewinde DIN 332, Blatt 2

#### KV574.02

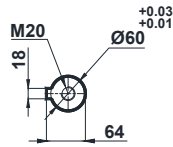
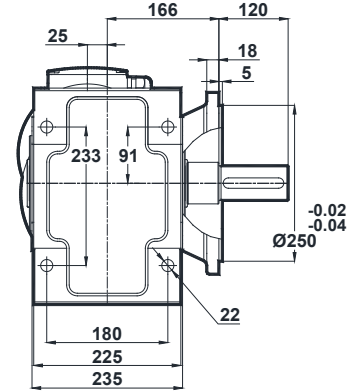
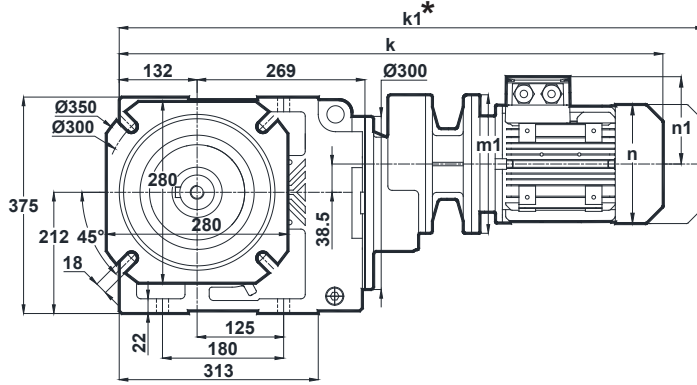

	71/B5	80/B5 80/B14	90S/B5 90S/B14	90L/B5 90L/B14	100L/B5
k	765	788	829	829	881
k1	856	881	933.5	933.5	1000.5
n / n1	137 / 112	155 / 121	176 / 132	176 / 132	193 / 147
m1 (B5)	160	200	200	200	250
m1 (B14)	-	120	140	140	160

Klemens Pozisyonları  
Terminal Box Positions  
Klemmenkasten Positionen

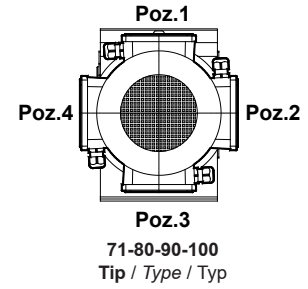

#### KV574.03

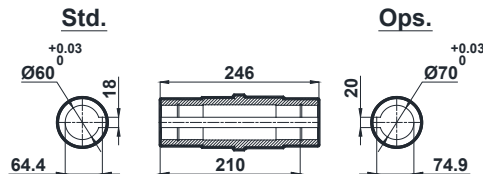
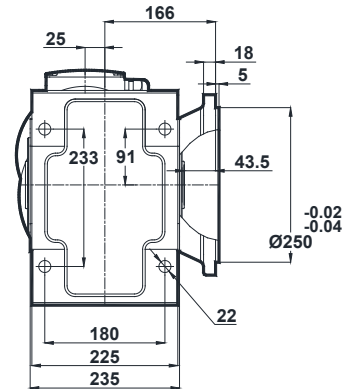
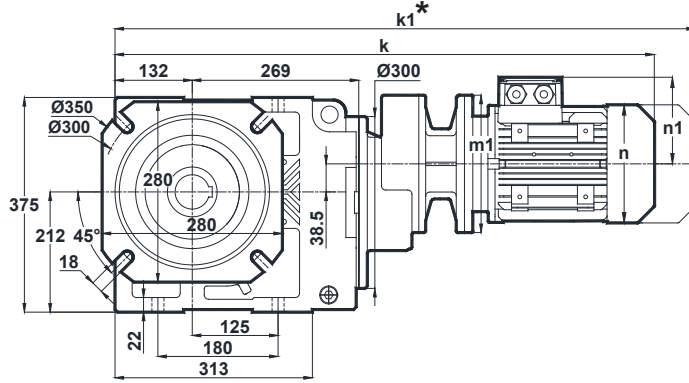

	71/B5	80/B5 80/B14	90S/B5 90S/B14	90L/B5 90L/B14	100L/B5
k	765	788	829	829	881
k1	856	881	933.5	933.5	1000.5
n / n1	137 / 112	155 / 121	176 / 132	176 / 132	193 / 147
m1 (B5)	160	200	200	200	250
m1 (B14)	-	120	140	140	160

\* " k1 " Ölçüsü frenli redüktörlere aittir.  
Dimension " k1 " is for motors with brake.  
Maße " k1 " ist für Bremsenmotoren.

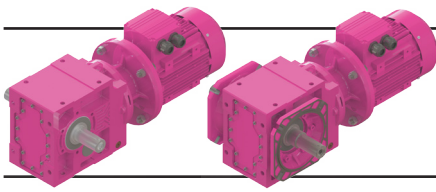

# Ölçü Sayfaları

## Dimension Pages

### Abmessungsseiten

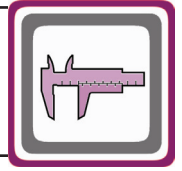

-Mil ucu çekirme deliği DIN 332 sayfa 2 / Tapped center hole to DIN 332, sheet 2 / Zentrierung mit Gewinde DIN 332, Blatt 2

#### KV574.04

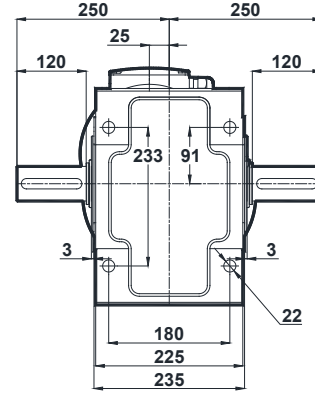
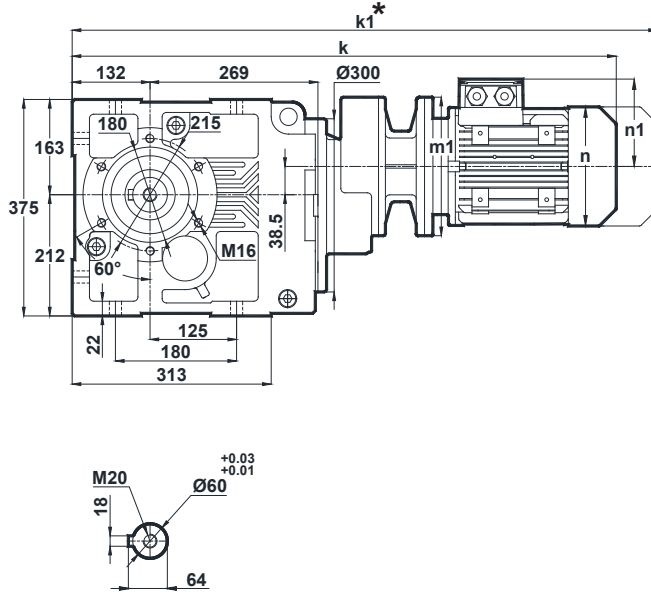

	71/B5	80/B5 80/B14	90S/B5 90S/B14	90L/B5 90L/B14	100L/B5
k	765	788	829	829	881
k1	856	881	933.5	933.5	1000.5
n / n1	137 / 112	155 / 121	176 / 132	176 / 132	193 / 147
m1 (B5)	160	200	200	200	250
m1 (B14)	-	120	140	140	160

**Klemens Pozisyonları**  
Terminal Box Positions  
Klemmenkasten Positionen

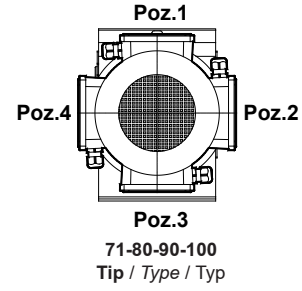

#### KV574.05

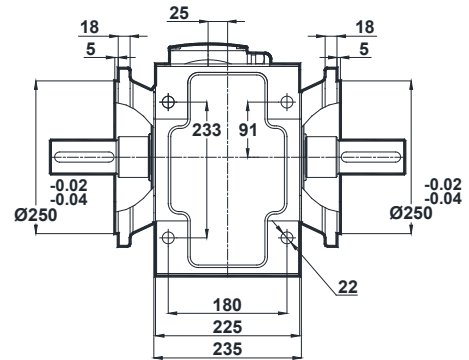
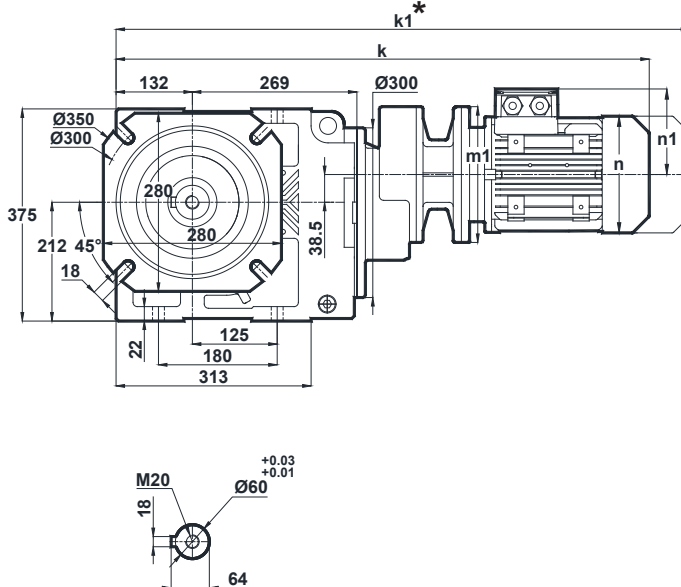

	71/B5	80/B5 80/B14	90S/B5 90S/B14	90L/B5 90L/B14	100L/B5
k	765	788	829	829	881
k1	856	881	933.5	933.5	1000.5
n / n1	137 / 112	155 / 121	176 / 132	176 / 132	193 / 147
m1 (B5)	160	200	200	200	250
m1 (B14)	-	120	140	140	160

\* "k1" Ölçüsü frenli redüktörlere aittir.  
Dimension "k1" is for motors with brake.  
Maße "k1" ist für Bremsenmotoren.



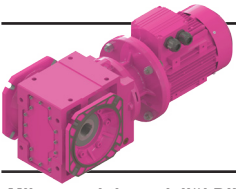

# Ölçü Sayfaları Dimension Pages Abmessungsseiten



-Mil ucu çektirme deliği DIN 332 sayfa 2 / Tapped center hole to DIN 332, sheet 2 / Zentrierung mit Gewinde DIN 332, Blatt 2

KV574.08

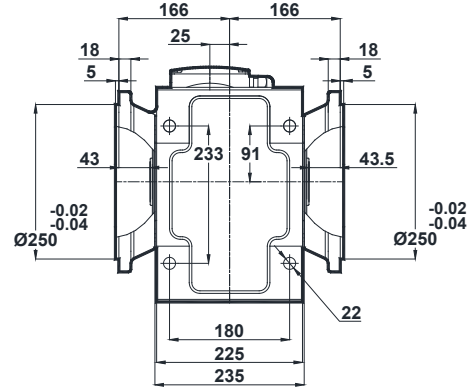
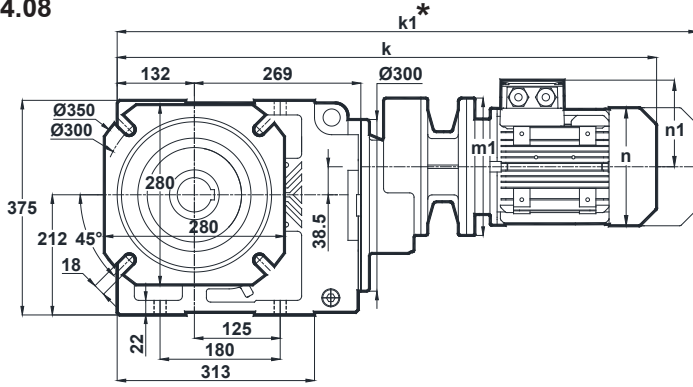

Std.

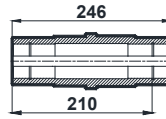
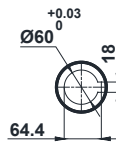

Ops.

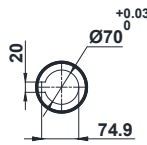

	71/B5	80/B5 80/B14	90S/B5 90S/B14	90L/B5 90L/B14	100L/B5
k	765	788	829	829	881
k1	856	881	933.5	933.5	1000.5
n / n1	137 / 112	155 / 121	176 / 132	176 / 132	193 / 147
m1 (B5)	160	200	200	200	250
m1 (B14)	-	120	140	140	160

Klemens Pozisyonları  
Terminal Box Positions  
Klemmenkasten Positionen

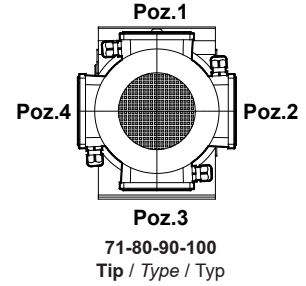

\* " k1 " Ölçüsü frenli redüktörlere aittir.  
Dimension " k1 " is for motors with brake.  
Maße " k1 " ist für Bremsenmotoren.

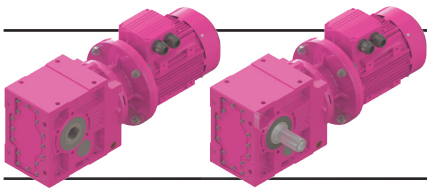

# Ölçü Sayfaları

## Dimension Pages

### Abmessungsseiten

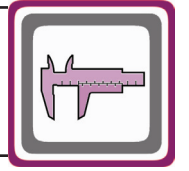

-Mil ucu çektirme deliği DIN 332 sayfa 2 / Tapped center hole to DIN 332, sheet 2 / Zentrierung mit Gewinde DIN 332, Blatt 2

KV575.00  
KV576.00

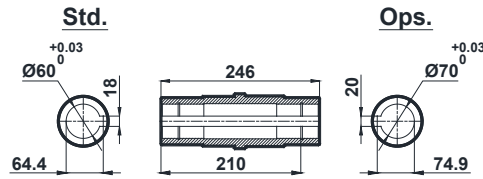
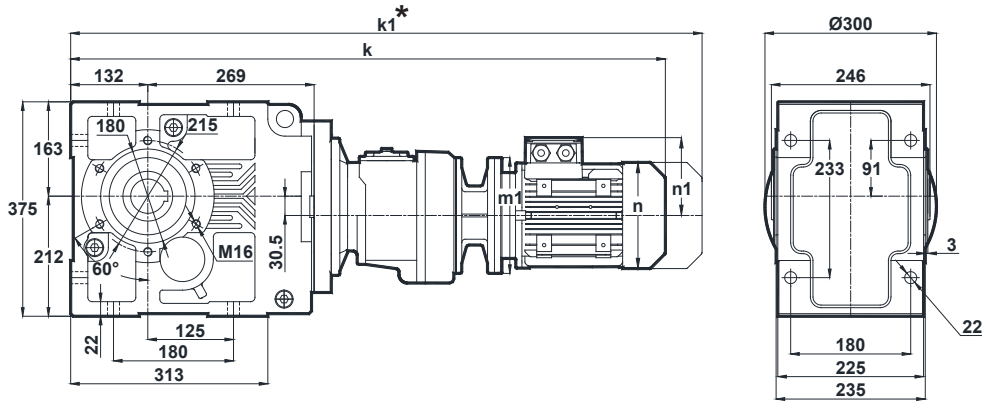

	63/B5	71/B5 71/B14	80/B5 80/B14
k	877	866	918
k1	938	957	1011
n / n1	121 / 97	137 / 112	155 / 121
m1 (B5)	140	160	200
m1 (B14)	-	105	120

Klemens Pozisyonları  
Terminal Box Positions  
Klemmenkasten Positionen

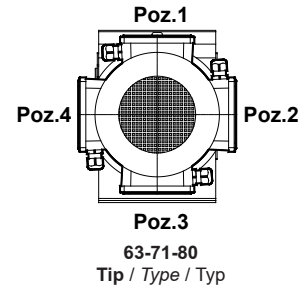

KV575.01  
KV576.01

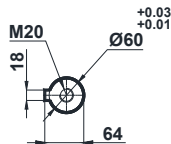
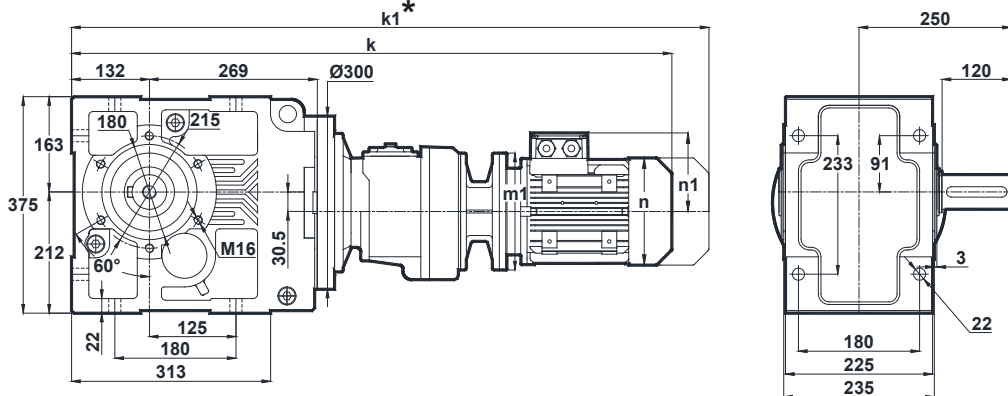

	63/B5	71/B5 71/B14	80/B5 80/B14
k	877	866	918
k1	938	957	1011
n / n1	121 / 97	137 / 112	155 / 121
m1 (B5)	140	160	200
m1 (B14)	-	105	120

\* "k1" Ölçüsü frenli redüktörlere aittir.  
Dimension "k1" is for motors with brake.  
Maße "k1" ist für Bremsenmotoren.

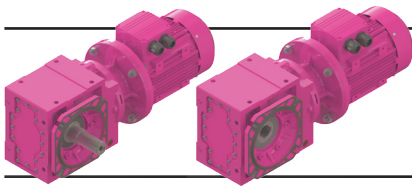

# Ölçü Sayfaları

## Dimension Pages

### Abmessungsseiten

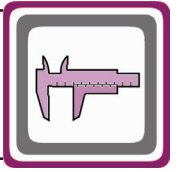

-Mil ucu çekirme deliği DIN 332 sayfa 2 / Tapped center hole to DIN 332, sheet 2 / Zentrierung mit Gewinde DIN 332, Blatt 2

**KV575.02**  
**KV576.02**

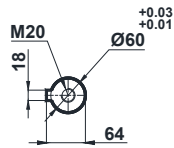
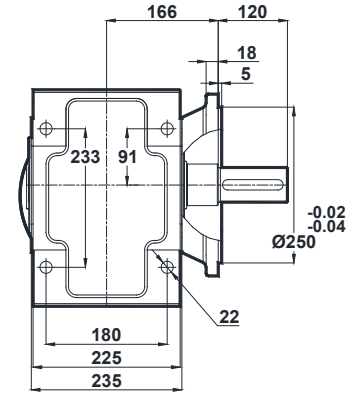
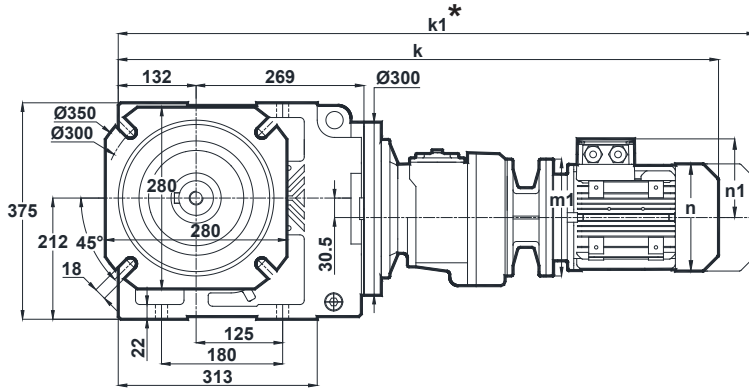

**Klemens Pozisyonları**  
Terminal Box Positions  
Klemmenkasten Positionen

	63/B5	71/B5 71/B14	80/B5 80/B14
k	877	866	918
k1	938	957	1011
n / n1	121 / 97	137 / 112	155 / 121
m1 (B5)	140	160	200
m1 (B14)	-	105	120

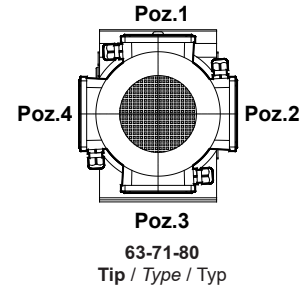

**KV575.03**  
**KV576.03**

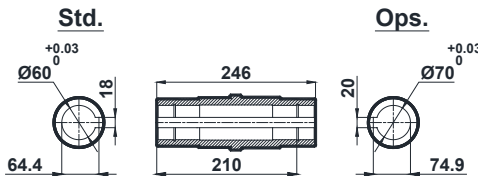
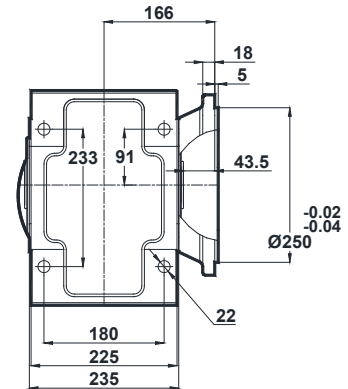
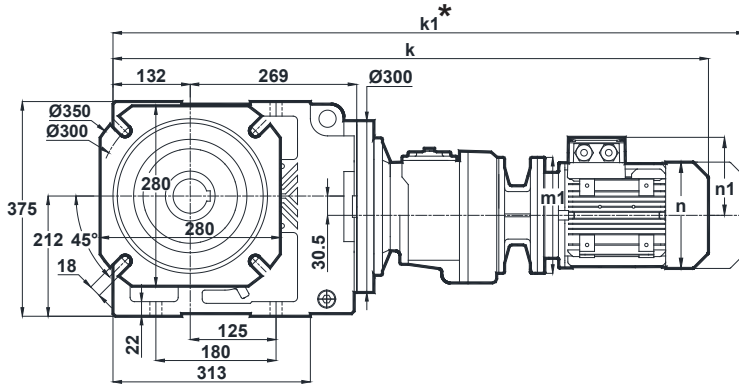

	63/B5	71/B5 71/B14	80/B5 80/B14
k	877	866	918
k1	938	957	1011
n / n1	121 / 97	137 / 112	155 / 121
m1 (B5)	140	160	200
m1 (B14)	-	105	120

\* " k1 " Ölçüsü frenli redüktörlere aittir.  
Dimension " k1 " is for motors with brake.  
Maße " k1 " ist für Bremsenmotoren.

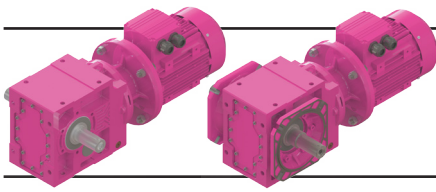

# Ölçü Sayfaları

## Dimension Pages

### Abmessungsseiten

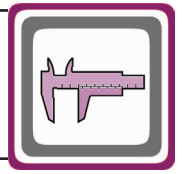

-Mil ucu çektirme deliği DIN 332 sayfa 2 / Tapped center hole to DIN 332, sheet 2 / Zentrierung mit Gewinde DIN 332, Blatt 2

**KV575.04**  
**KV576.04**

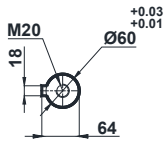
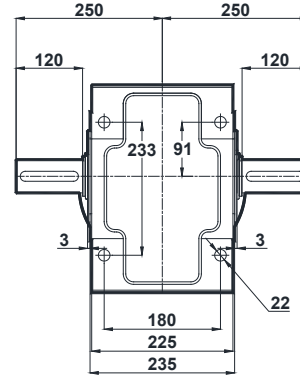
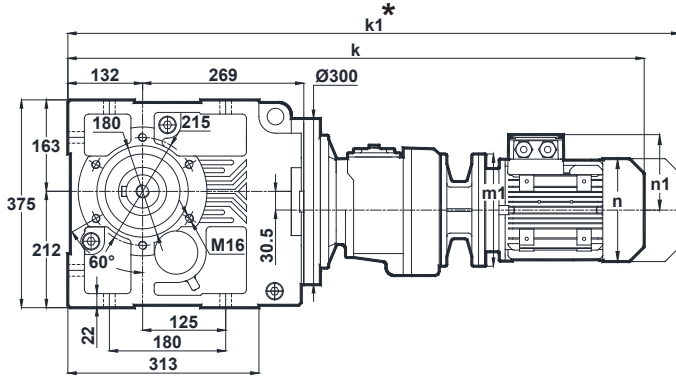

	63/B5	71/B5 71/B14	80/B5 80/B14
k	877	866	918
k1	938	957	1011
n / n1	121 / 97	137 / 112	155 / 121
m1 (B5)	140	160	200
m1 (B14)	-	105	120

**Klemens Pozisyonları**  
Terminal Box Positions  
Klemmenkasten Positionen

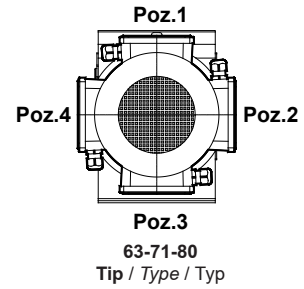

**KV575.05**  
**KV576.05**

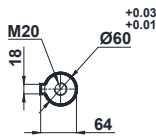
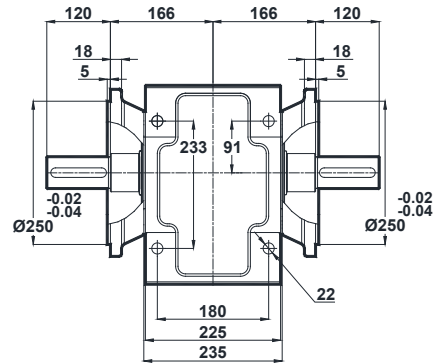
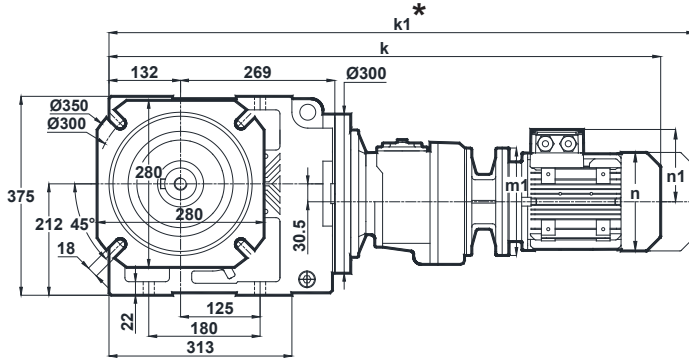

	63/B5	71/B5 71/B14	80/B5 80/B14
k	877	866	918
k1	938	957	1011
n / n1	121 / 97	137 / 112	155 / 121
m1 (B5)	140	160	200
m1 (B14)	-	105	120

\* " k1 " Ölçüsü frenli redüktörlere aittir.  
Dimension " k1 " is for motors with brake.  
Maße " k1 " ist für Bremsenmotoren.

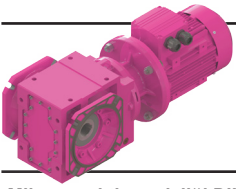

# Ölçü Sayfaları Dimension Pages Abmessungenseiten

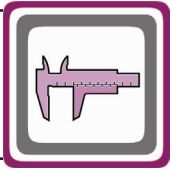

-Mil ucu çekirme deliği DIN 332 sayfa 2 / Tapped center hole to DIN 332, sheet 2 / Zentrierung mit Gewinde DIN 332, Blatt 2

KV575.08  
KV576.08

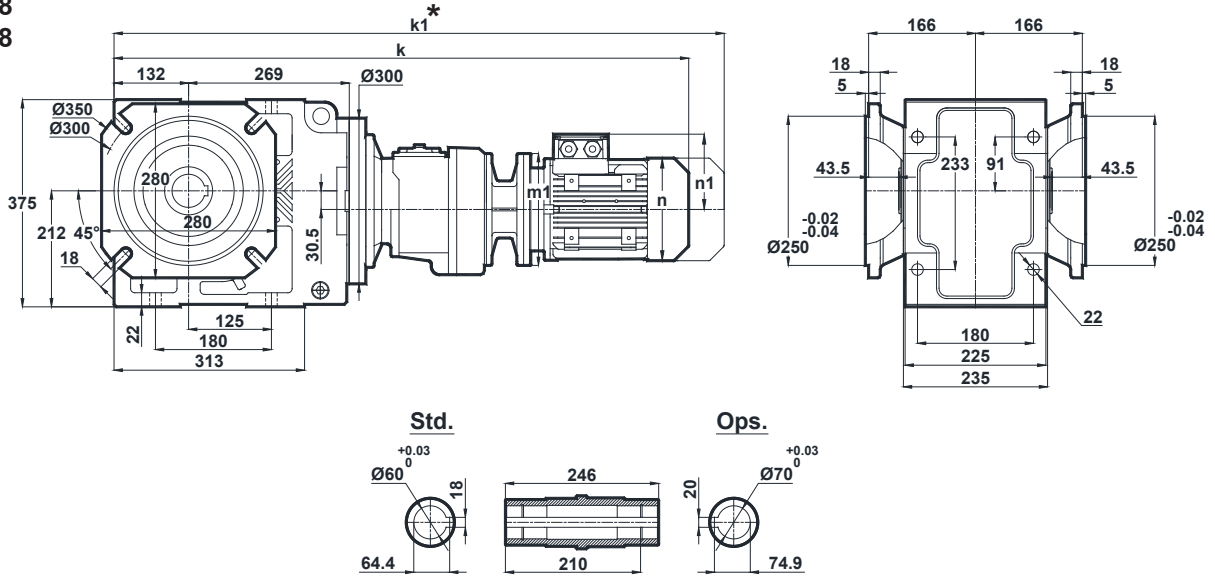

	63/B5	71/B5 71/B14	80/B5 80/B14
k	877	866	918
k1	938	957	1011
n / n1	121 / 97	137 / 112	155 / 121
m1 (B5)	140	160	200
m1 (B14)	-	105	120

Klemens Pozisyonları  
Terminal Box Positions  
Klemmenkasten Positionen

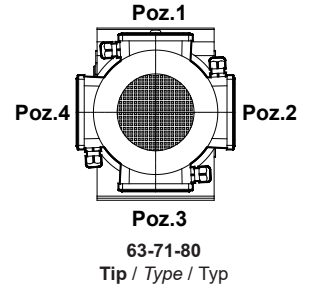

\* " k1 " Ölçüsü frenli redüktörlere aittir.  
Dimension " k1 " is for motors with brake.  
Maße " k1 " ist für Bremsenmotoren.

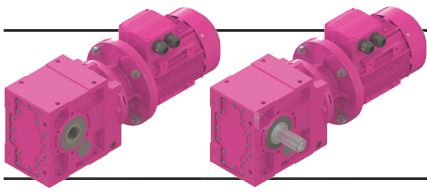

# Ölçü Sayfaları

## Dimension Pages

### Abmessungsseiten

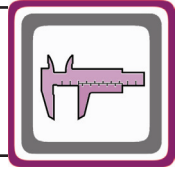

-Mil ucu çektirme deliği DIN 332 sayfa 2 / Tapped center hole to DIN 332, sheet 2 / Zentrierung mit Gewinde DIN 332, Blatt 2

#### KV673.00

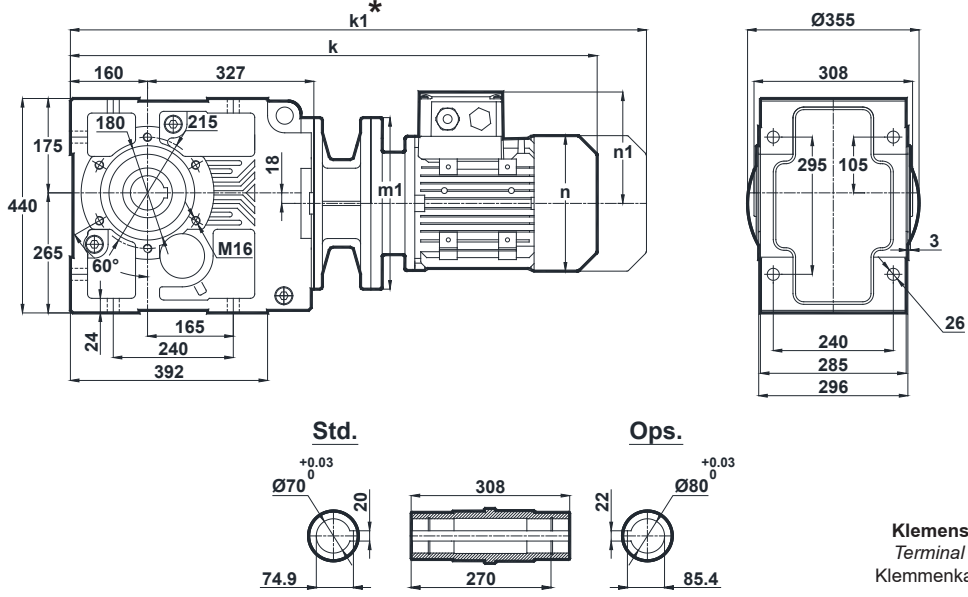

**Klemens Pozisyonları**  
Terminal Box Positions  
Klemmenkasten Positionen

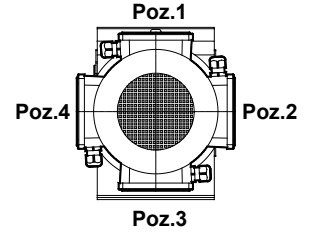

100-112-132-160-180-200-225  
Tip / Type / Typ

	100L/B5	112M/B5	132S/B5 132S/B14	132M/B5 132M/B14	160M/B5	160L/B5	180M/B5	180L/B5	200L/B5	225S/B5	225M/B5
<b>k</b>	866	887	986	986	1140	1140	1230	1230	1303	1374	1399
<b>k1</b>	985.5	991.5	1116	1116	1320	1320	1400.5	1400.5	1489.5	1539	1564
<b>n / n1</b>	193 / 147	215 / 158	257 / 179	257 / 179	315 / 219	315 / 219	347 / 234	347 / 234	390 / 275	434 / 285	434 / 285
<b>m1 (B5)</b>	250	250	300	300	350	350	350	350	400	450	450
<b>m1 (B14)</b>	-	-	200	200	-	-	-	-	-	-	-

#### KV673.01

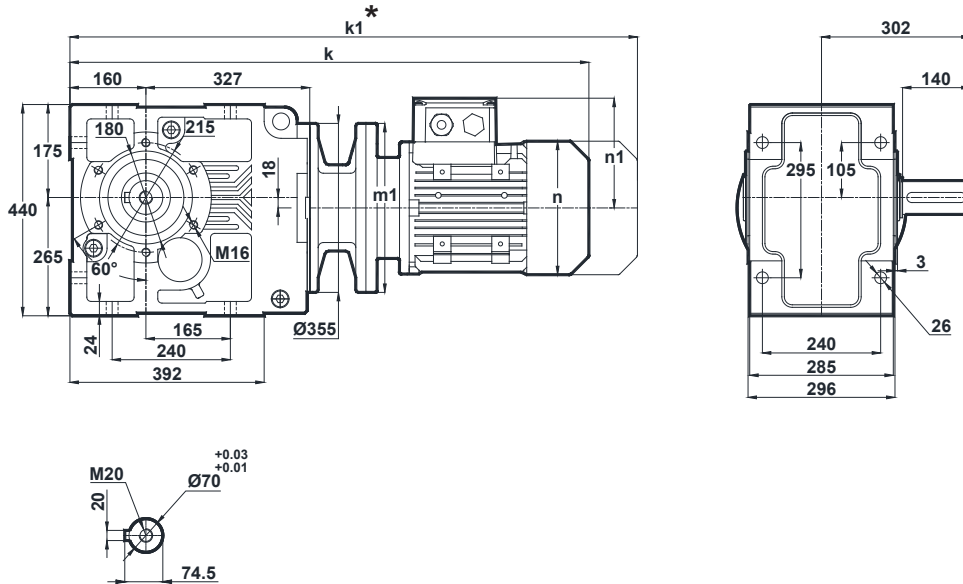

	100L/B5	112M/B5	132S/B5 132S/B14	132M/B5 132M/B14	160M/B5	160L/B5	180M/B5	180L/B5	200L/B5	225S/B5	225M/B5
<b>k</b>	866	887	986	986	1140	1140	1230	1230	1303	1374	1399
<b>k1</b>	985.5	991.5	1116	1116	1320	1320	1400.5	1400.5	1489.5	1539	1564
<b>n / n1</b>	193 / 147	215 / 158	257 / 179	257 / 179	315 / 219	315 / 219	347 / 234	347 / 234	390 / 275	434 / 285	434 / 285
<b>m1 (B5)</b>	250	250	300	300	350	350	350	350	400	450	450
<b>m1 (B14)</b>	-	-	200	200	-	-	-	-	-	-	-

\* "k1" Ölçüsü frenli redüktörlere aittir.  
Dimension "k1" is for motors with brake.  
Maße "k1" ist für Bremsmotoren.

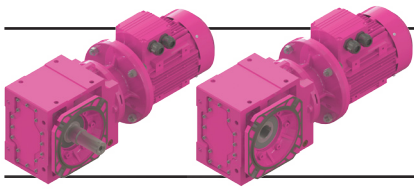

# Ölçü Sayfaları Dimension Pages Abmessungsseiten

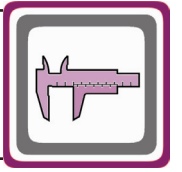

-Mil ucu çektirme deliği DIN 332 sayfa 2 / Tapped center hole to DIN 332, sheet 2 / Zentrierung mit Gewinde DIN 332, Blatt 2

## KV673.02

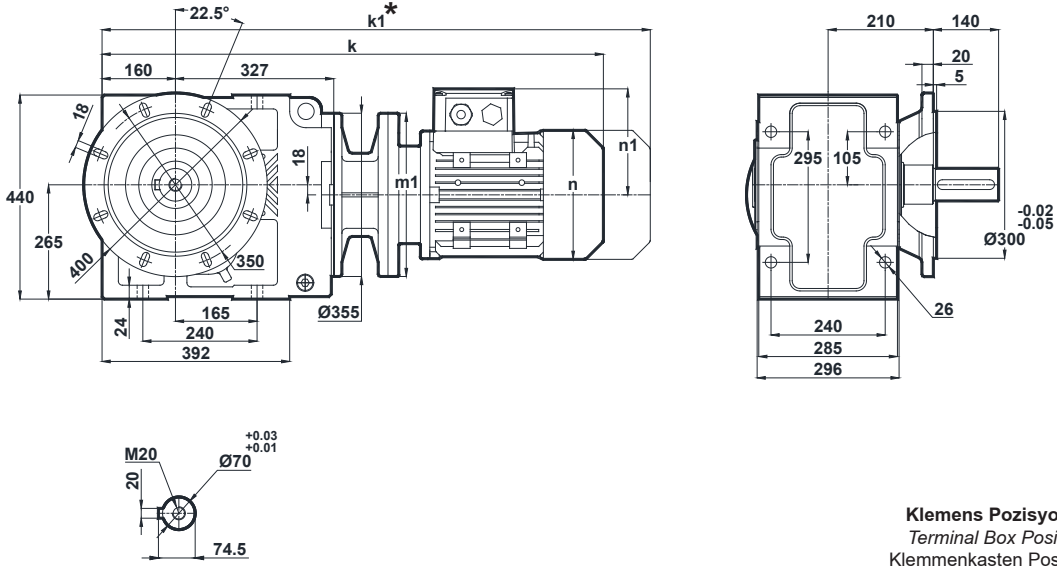

	100L/B5	112M/B5	132S/B5 132S/B14	132M/B5 132M/B14	160M/B5	160L/B5	180M/B5	180L/B5	200L/B5	225S/B5	225M/B5
k	866	887	986	986	1140	1140	1230	1230	1303	1374	1399
k1	985.5	991.5	1116	1116	1320	1320	1400.5	1400.5	1489.5	1539	1564
n / n1	193 / 147	215 / 158	257 / 179	257 / 179	315 / 219	315 / 219	347 / 234	347 / 234	390 / 275	434 / 285	434 / 285
m1 (B5)	250	250	300	300	350	350	350	350	400	450	450
m1 (B14)	-	-	200	200	-	-	-	-	-	-	-

Klemens Pozisyonları  
Terminal Box Positions  
Klemmenkasten Positionen

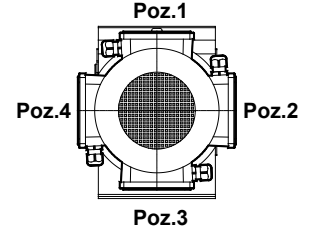

100-112-132-160-180-200-225  
Tip / Type / Typ

## KV673.03

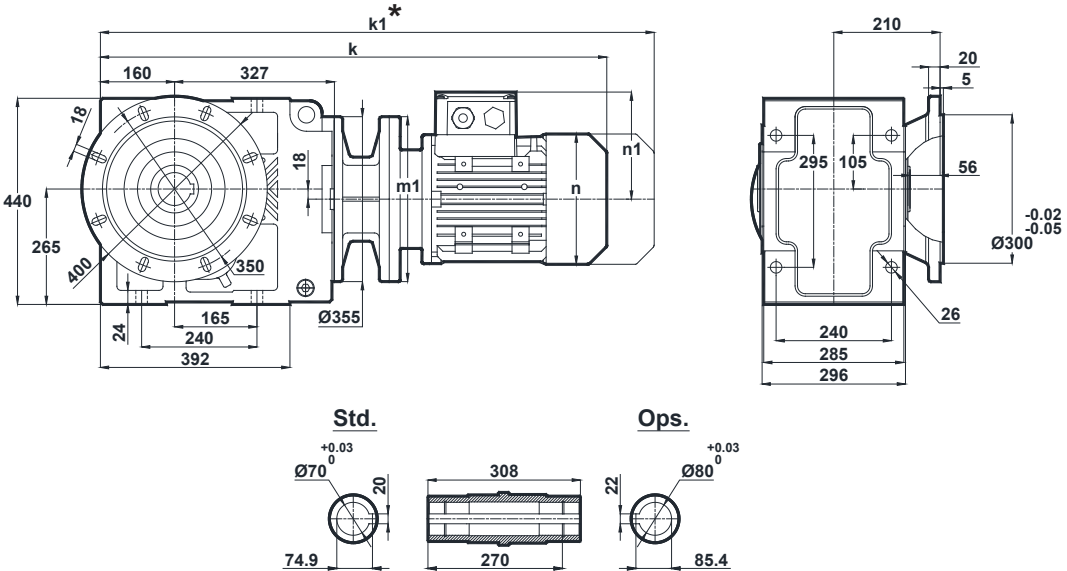

	100L/B5	112M/B5	132S/B5 132S/B14	132M/B5 132M/B14	160M/B5	160L/B5	180M/B5	180L/B5	200L/B5	225S/B5	225M/B5
k	866	887	986	986	1140	1140	1230	1230	1303	1374	1399
k1	985.5	991.5	1116	1116	1320	1320	1400.5	1400.5	1489.5	1539	1564
n / n1	193 / 147	215 / 158	257 / 179	257 / 179	315 / 219	315 / 219	347 / 234	347 / 234	390 / 275	434 / 285	434 / 285
m1 (B5)	250	250	300	300	350	350	350	350	400	450	450
m1 (B14)	-	-	200	200	-	-	-	-	-	-	-

\* " k1 " Ölçüsü frenli redüktörlere aittir.  
Dimension " k1 " is for motors with brake.  
Maße " k1 " ist für Bremsenmotoren.

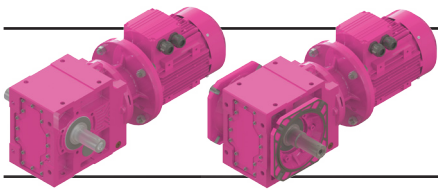

# Ölçü Sayfaları

## Dimension Pages

### Abmessungsseiten

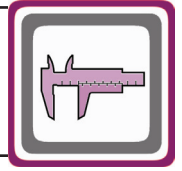

-Mil ucu çektirme deliği DIN 332 sayfa 2 / Tapped center hole to DIN 332, sheet 2 / Zentrierung mit Gewinde DIN 332, Blatt 2

#### KV673.04

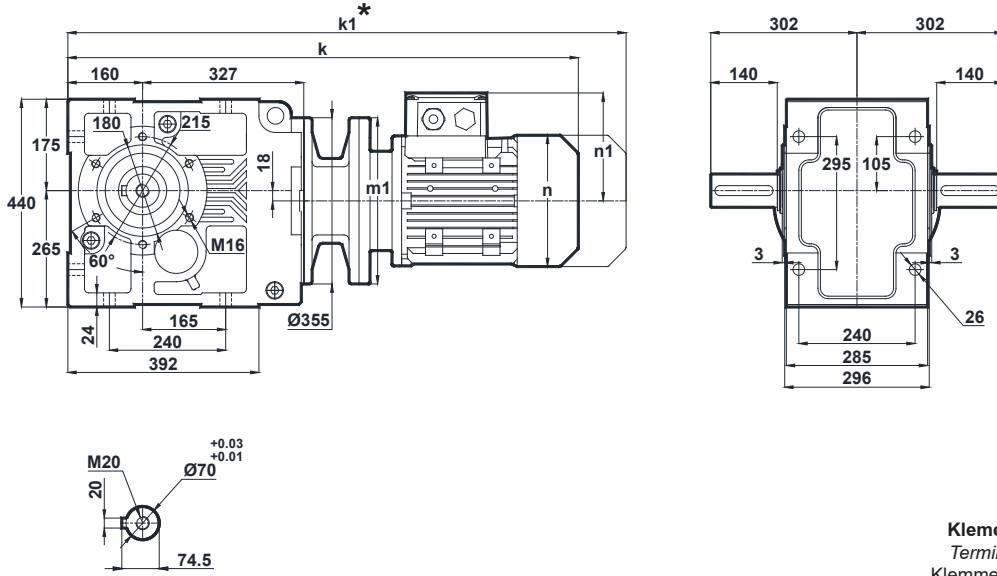

**Klemens Pozisyonları**  
Terminal Box Positions  
Klemmenkasten Positionen

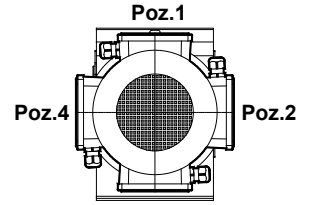

**Poz.3**  
100-112-132-160-180-200-225  
Tip / Type / Typ

	100L/B5	112M/B5	132S/B5 132S/B14	132M/B5 132M/B14	160M/B5	160L/B5	180M/B5	180L/B5	200L/B5	225S/B5	225M/B5
<b>k</b>	866	887	986	986	1140	1140	1230	1230	1303	1374	1399
<b>k1</b>	985.5	991.5	1116	1116	1320	1320	1400.5	1400.5	1489.5	1539	1564
<b>n / n1</b>	193 / 147	215 / 158	257 / 179	257 / 179	315 / 219	315 / 219	347 / 234	347 / 234	390 / 275	434 / 285	434 / 285
<b>m1 (B5)</b>	250	250	300	300	350	350	350	350	400	450	450
<b>m1 (B14)</b>	-	-	200	200	-	-	-	-	-	-	-

#### KV673.05

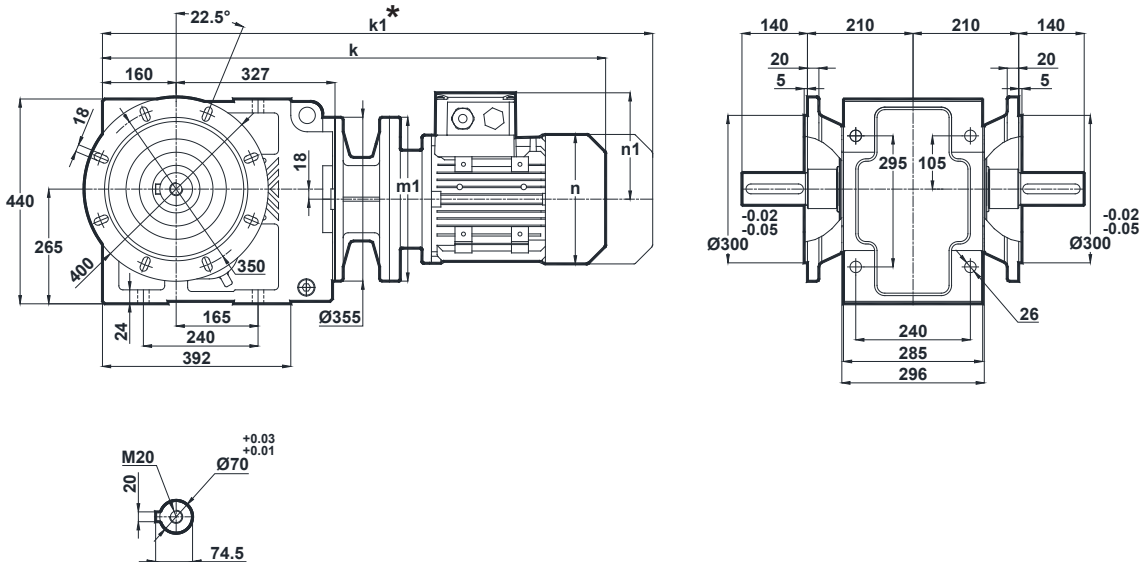

	100L/B5	112M/B5	132S/B5 132S/B14	132M/B5 132M/B14	160M/B5	160L/B5	180M/B5	180L/B5	200L/B5	225S/B5	225M/B5
<b>k</b>	866	887	986	986	1140	1140	1230	1230	1303	1374	1399
<b>k1</b>	985.5	991.5	1116	1116	1320	1320	1400.5	1400.5	1489.5	1539	1564
<b>n / n1</b>	193 / 147	215 / 158	257 / 179	257 / 179	315 / 219	315 / 219	347 / 234	347 / 234	390 / 275	434 / 285	434 / 285
<b>m1 (B5)</b>	250	250	300	300	350	350	350	350	400	450	450
<b>m1 (B14)</b>	-	-	200	200	-	-	-	-	-	-	-

\* "k1" Ölçüsü frenli redüktörlere aittir.  
Dimension "k1" is for motors with brake.  
Maße "k1" ist für Bremsenmotoren.



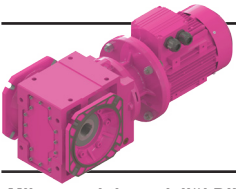

# Ölçü Sayfaları Dimension Pages Abmessungsseiten



-Mil ucu çektirme deliği DIN 332 sayfa 2 / Tapped center hole to DIN 332, sheet 2 / Zentrierung mit Gewinde DIN 332, Blatt 2

KV673.08

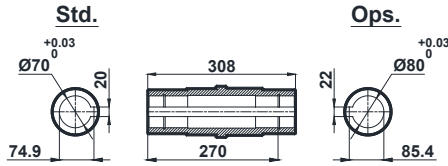
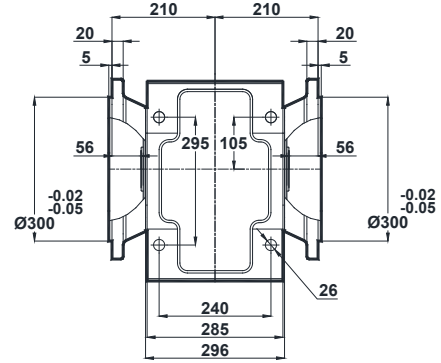
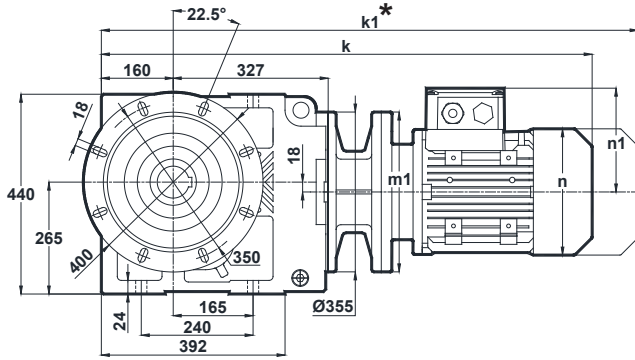

Klemens Pozisyonları  
Terminal Box Positions  
Klemmenkasten Positionen

	100L/B5	112M/B5	132S/B5 132S/B14	132M/B5 132M/B14	160M/B5	160L/B5	180M/B5	180L/B5	200L/B5	225S/B5	225M/B5
k	866	887	986	986	1140	1140	1230	1230	1303	1374	1399
k1	985.5	991.5	1116	1116	1320	1320	1400.5	1400.5	1489.5	1539	1564
n / n1	193 / 147	215 / 158	257 / 179	257 / 179	315 / 219	315 / 219	347 / 234	347 / 234	390 / 275	434 / 285	434 / 285
m1 (B5)	250	250	300	300	350	350	350	350	400	450	450
m1 (B14)	-	-	200	200	-	-	-	-	-	-	-

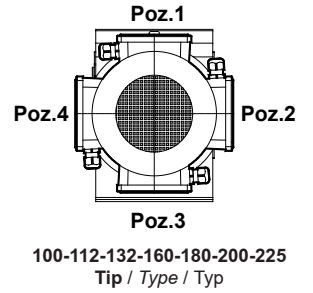

\* " k1 " Ölçüsü frenli redüktörlere aittir.  
Dimension " k1 " is for motors with brake.  
Maße " k1 " ist für Bremsenmotoren.

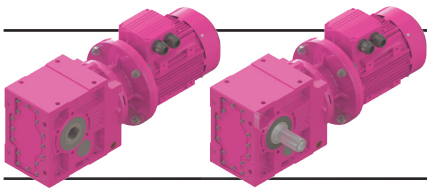

# Ölçü Sayfaları

## Dimension Pages

### Abmessungsseiten

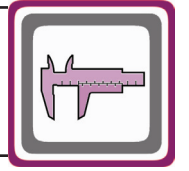

-Mil ucu çekirme deliği DIN 332 sayfa 2 / Tapped center hole to DIN 332, sheet 2 / Zentrierung mit Gewinde DIN 332, Blatt 2

#### KV674.00

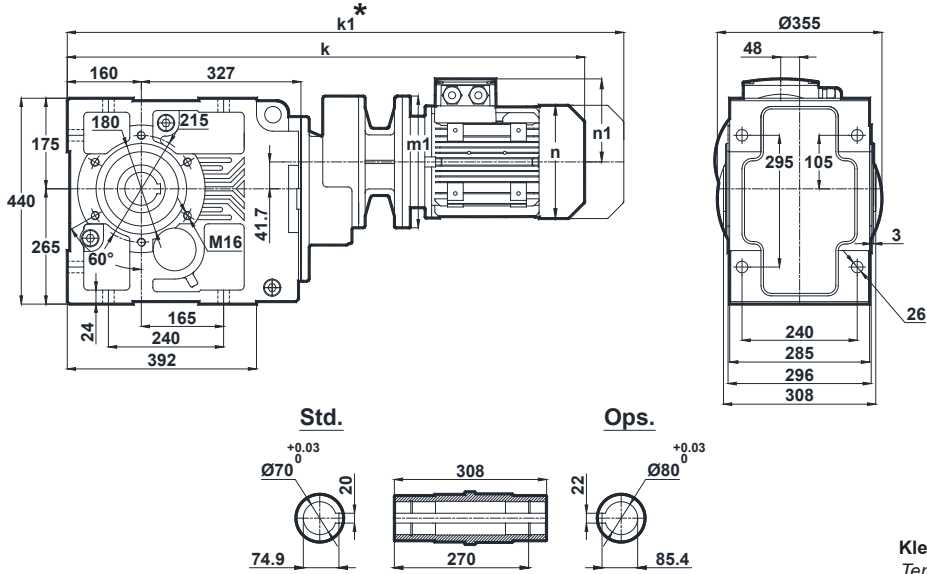

**Klemens Pozisyonları**  
Terminal Box Positions  
Klemmenkasten Positionen

	80/B5	90S/B5 90S/B14	90L/B5 90L/B14	100L/B5 100L/B14
k	880	921	921	975
k1	973	1025.5	1025.5	1094.5
n / n1	155 / 121	176 / 132	176 / 132	193 / 147
m1 (B5)	200	200	200	250
m1 (B14)	-	140	140	160

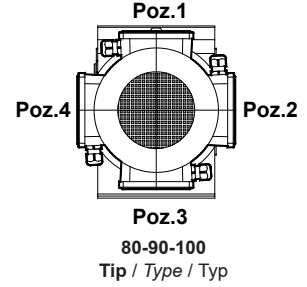

#### KV674.01

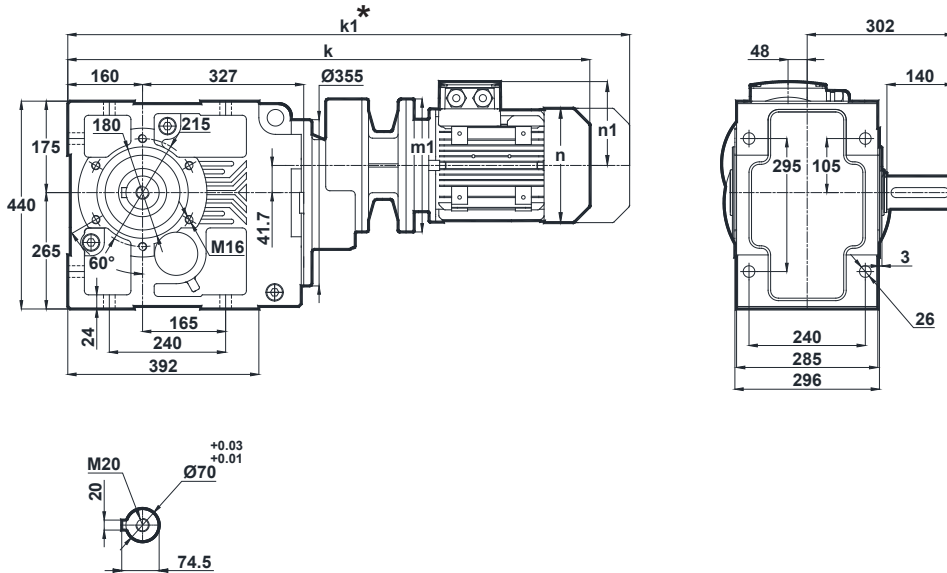

	80/B5	90S/B5 90S/B14	90L/B5 90L/B14	100L/B5 100L/B14
k	880	921	921	975
k1	973	1025.5	1025.5	1094.5
n / n1	155 / 121	176 / 132	176 / 132	193 / 147
m1 (B5)	200	200	200	250
m1 (B14)	-	140	140	160

\* " k1 " Ölçüsü frenli redüktörlere aittir.  
Dimension " k1 " is for motors with brake.  
Maße " k1 " ist für Bremsenmotoren.

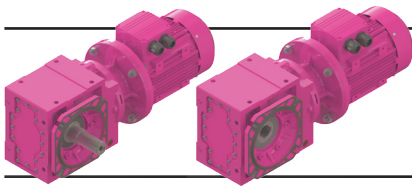

# Ölçü Sayfaları

## Dimension Pages

### Abmessungsseiten



-Mil ucu çektirme deliği DIN 332 sayfa 2 / Tapped center hole to DIN 332, sheet 2 / Zentrierung mit Gewinde DIN 332, Blatt 2

#### KV674.02

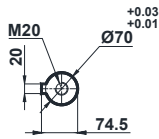
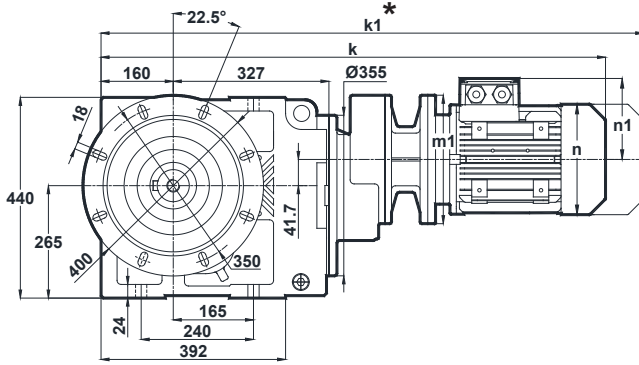

Klemens Pozisyonları  
Terminal Box Positions  
Klemmenkasten Positionen

	80/B5	90S/B5 90S/B14	90L/B5 90L/B14	100L/B5 100L/B14
k	880	921	921	975
k1	973	1025.5	1025.5	1094.5
n / n1	155 / 121	176 / 132	176 / 132	193 / 147
m1 (B5)	200	200	200	250
m1 (B14)	-	140	140	160

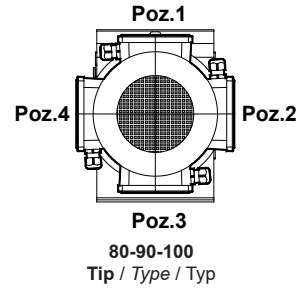

#### KV674.03

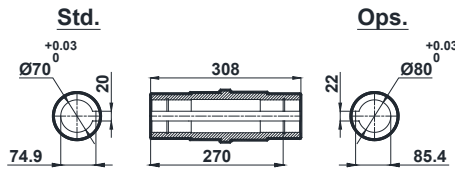
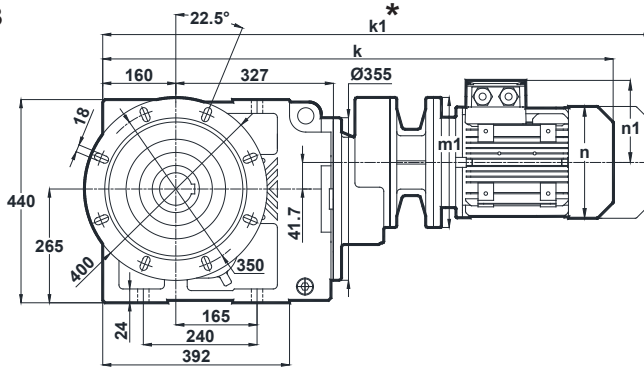

	80/B5	90S/B5 90S/B14	90L/B5 90L/B14	100L/B5 100L/B14
k	880	921	921	975
k1	973	1025.5	1025.5	1094.5
n / n1	155 / 121	176 / 132	176 / 132	193 / 147
m1 (B5)	200	200	200	250
m1 (B14)	-	140	140	160

\* " k1 " Ölçüsü frenli redüktörlere aittir.  
Dimension " k1 " is for motors with brake.  
Maße " k1 " ist für Bremsenmotoren.

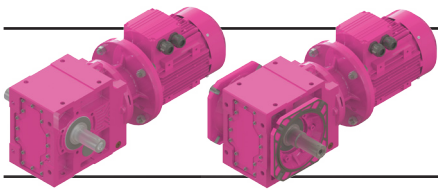

# Ölçü Sayfaları

## Dimension Pages

### Abmessungsseiten

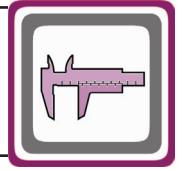

-Mil ucu çekirme deliği DIN 332 sayfa 2 / Tapped center hole to DIN 332, sheet 2 / Zentrierung mit Gewinde DIN 332, Blatt 2

#### KV674.04

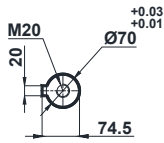
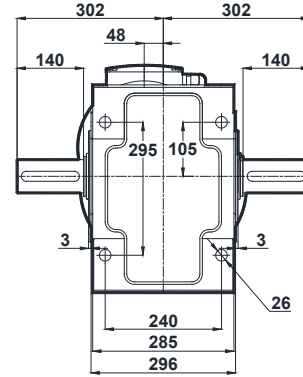
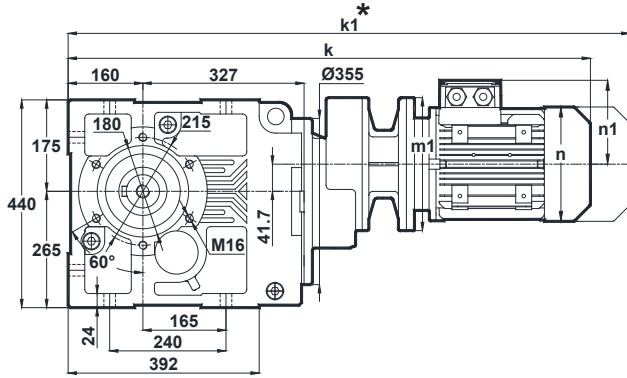

Klemens Pozisyonları  
Terminal Box Positions  
Klemmenkasten Positionen

	80/B5	90S/B5 90S/B14	90L/B5 90L/B14	100L/B5 100L/B14
k	880	921	921	975
k1	973	1025.5	1025.5	1094.5
n / n1	155 / 121	176 / 132	176 / 132	193 / 147
m1 (B5)	200	200	200	250
m1 (B14)	-	140	140	160

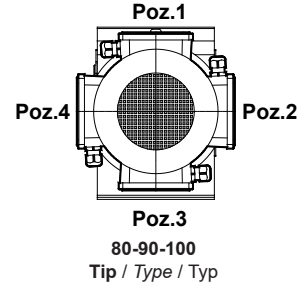

#### KV674.05

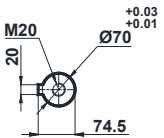
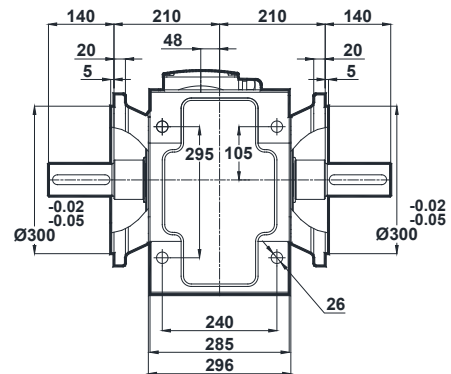
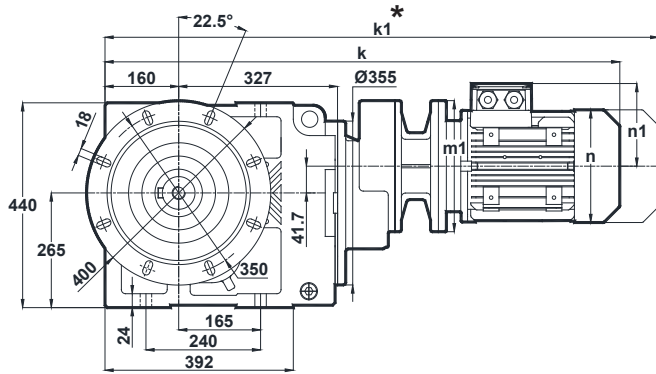

	80/B5	90S/B5 90S/B14	90L/B5 90L/B14	100L/B5 100L/B14
k	880	921	921	975
k1	973	1025.5	1025.5	1094.5
n / n1	155 / 121	176 / 132	176 / 132	193 / 147
m1 (B5)	200	200	200	250
m1 (B14)	-	140	140	160

\* " k1 " Ölçüsü frenli redüktörlere aittir.  
Dimension " k1 " is for motors with brake.  
Maße " k1 " ist für Bremsenmotoren.

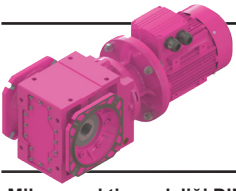

# Ölçü Sayfaları Dimension Pages Abmessungsseiten

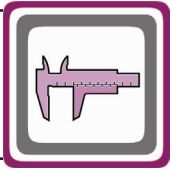

-Mil ucu çektirme deliği DIN 332 sayfa 2 / Tapped center hole to DIN 332, sheet 2 / Zentrierung mit Gewinde DIN 332, Blatt 2

KV674.08

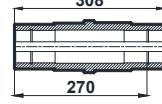
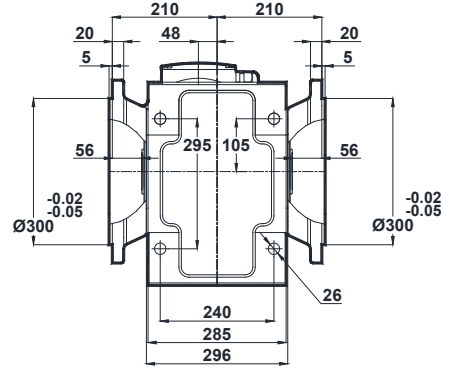
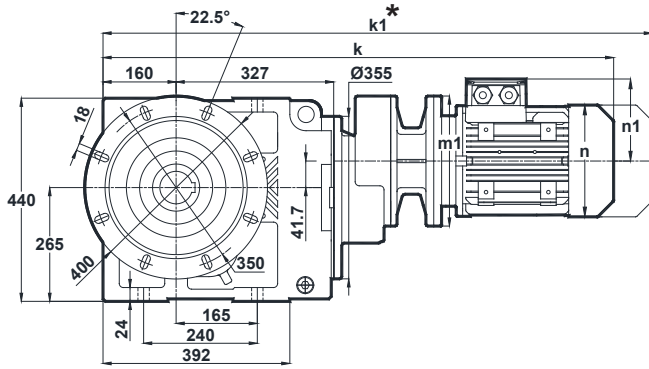

Klemens Pozisyonları  
Terminal Box Positions  
Klemmenkasten Positionen

	80/B5	90S/B5 90S/B14	90L/B5 90L/B14	100L/B5 100L/B14
k	880	921	921	975
k1	973	1025.5	1025.5	1094.5
n / n1	155 / 121	176 / 132	176 / 132	193 / 147
m1 (B5)	200	200	200	250
m1 (B14)	-	140	140	160

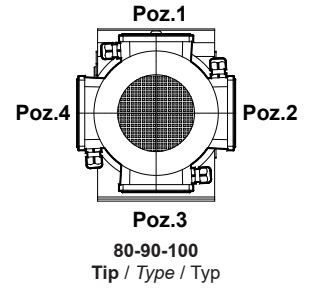

\* " k1 " Ölçüsü frenli redüktörlere aittir.  
Dimension " k1 " is for motors with brake.  
Maße " k1 " ist für Bremsenmotoren.

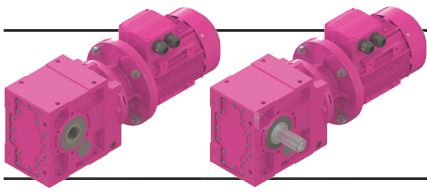

# Ölçü Sayfaları

## Dimension Pages

### Abmessungsseiten

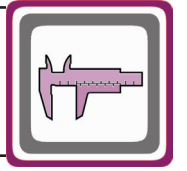

-Mil ucu çektirme deliği DIN 332 sayfa 2 / Tapped center hole to DIN 332, sheet 2 / Zentrierung mit Gewinde DIN 332, Blatt 2

**KV675.00**  
**KV676.00**

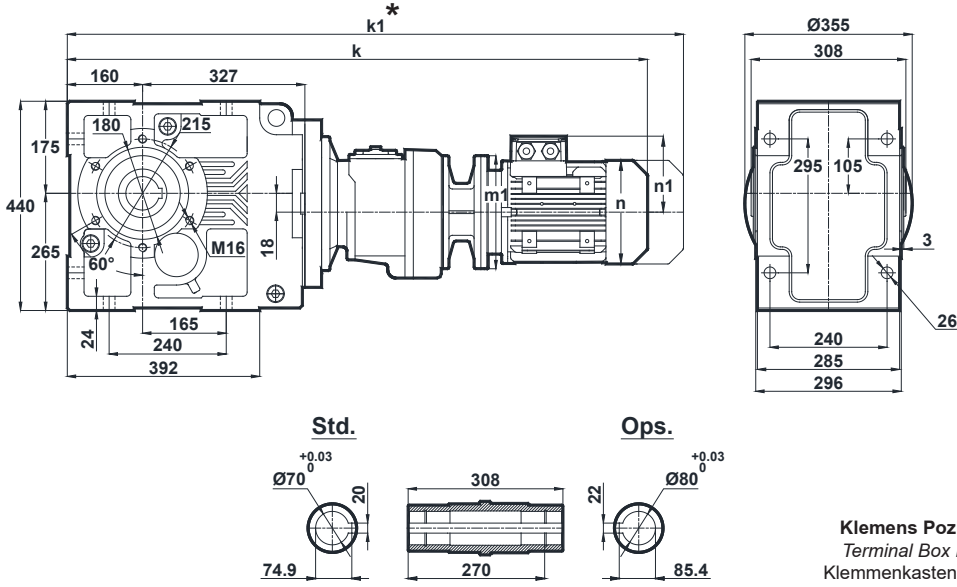

**Klemens Pozisyonları**  
Terminal Box Positions  
Klemmenkasten Positionen

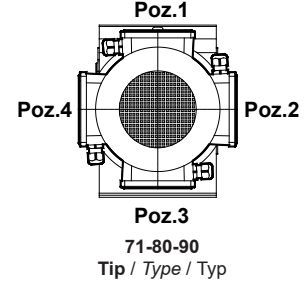

	71/B5	80/B5 80/B14	90S/B5 90S/B14	90L/B5 90L/B14
k	1008	1031	1072	1072
k1	1099	1124	1176.5	1176.5
n / n1	137 / 112	155 / 121	176 / 132	176 / 132
m1 (B5)	160	200	200	200
m1 (B14)	-	120	140	140

**KV675.01**  
**KV676.01**

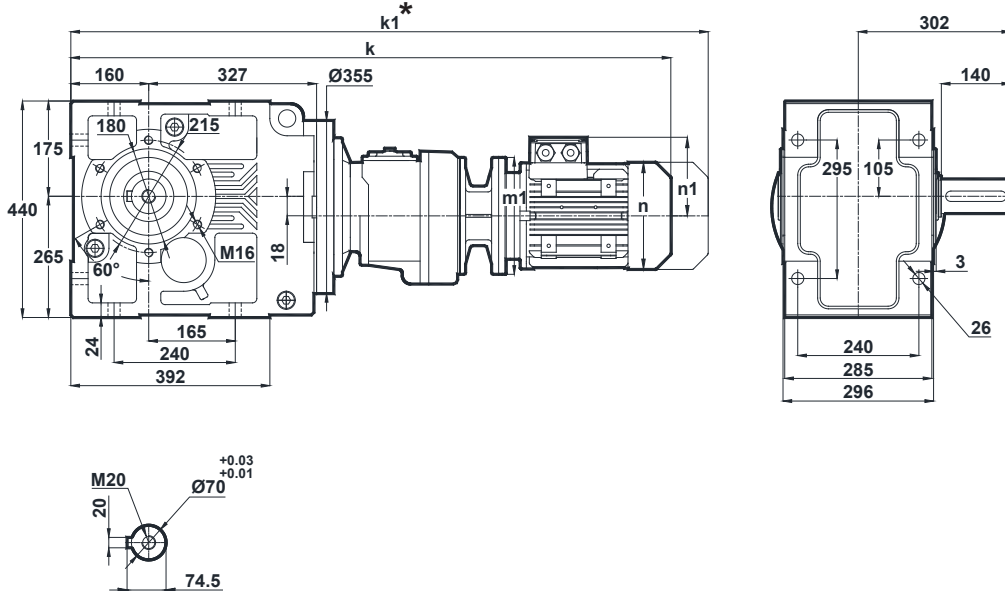

	71/B5	80/B5 80/B14	90S/B5 90S/B14	90L/B5 90L/B14
k	1008	1031	1072	1072
k1	1099	1124	1176.5	1176.5
n / n1	137 / 112	155 / 121	176 / 132	176 / 132
m1 (B5)	160	200	200	200
m1 (B14)	-	120	140	140

\* "k1" Ölçüsü frenli redüktörlere aittir.  
Dimension "k1" is for motors with brake.  
Maße "k1" ist für Bremsenmotoren.

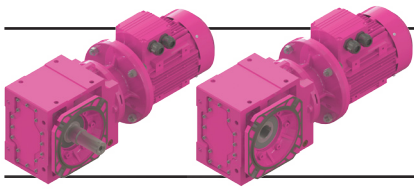

# Ölçü Sayfaları

## Dimension Pages

### Abmessungsseiten

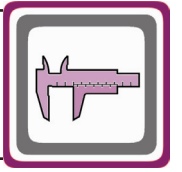

-Mil ucu çektirme deliği DIN 332 sayfa 2 / Tapped center hole to DIN 332, sheet 2 / Zentrierung mit Gewinde DIN 332, Blatt 2

KV675.02  
KV676.02

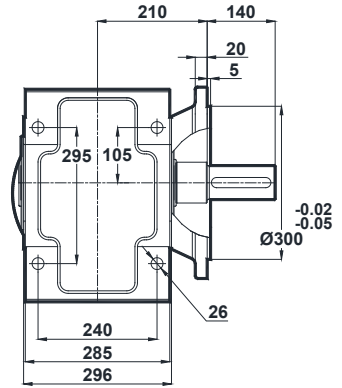
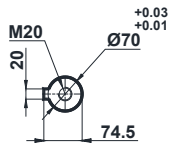
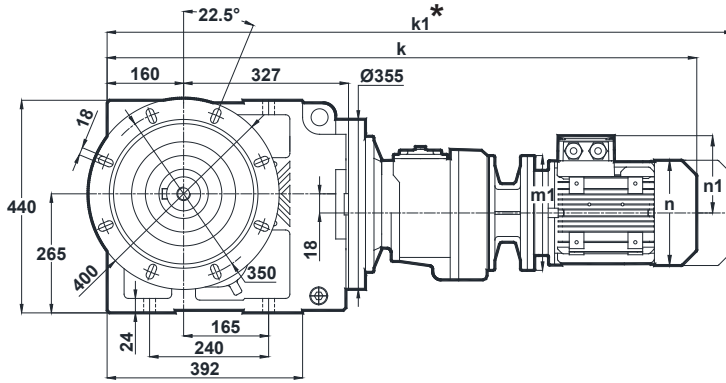

**Klemens Pozisyonları**  
Terminal Box Positions  
Klemmenkasten Positionen

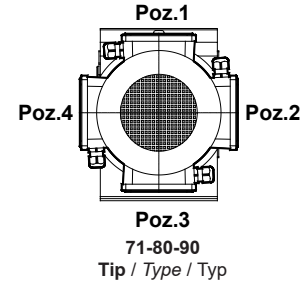

	71/B5	80/B5 80/B14	90S/B5 90S/B14	90L/B5 90L/B14
k	1008	1031	1072	1072
k1	1099	1124	1176.5	1176.5
n / n1	137 / 112	155 / 121	176 / 132	176 / 132
m1 (B5)	160	200	200	200
m1 (B14)	-	120	140	140

KV675.03  
KV676.03

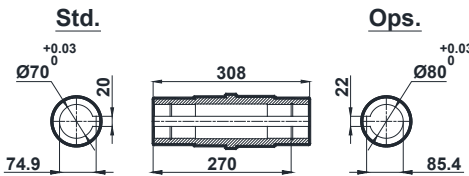
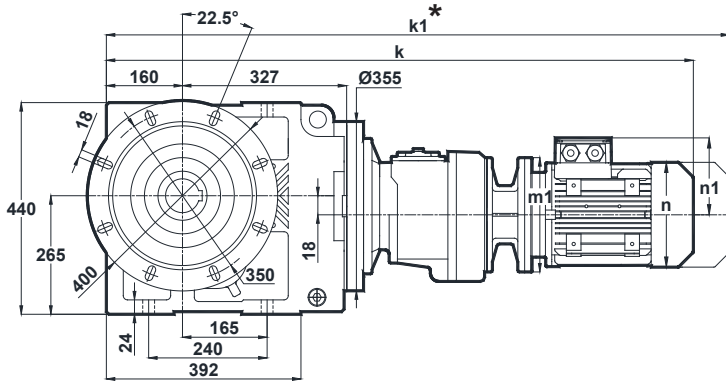

	71/B5	80/B5 80/B14	90S/B5 90S/B14	90L/B5 90L/B14
k	1008	1031	1072	1072
k1	1099	1124	1176.5	1176.5
n / n1	137 / 112	155 / 121	176 / 132	176 / 132
m1 (B5)	160	200	200	200
m1 (B14)	-	120	140	140

\* " k1 " Ölçüsü frenli redüktörlere aittir.  
Dimension " k1 " is for motors with brake.  
Maße " k1 " ist für Bremsenmotoren.

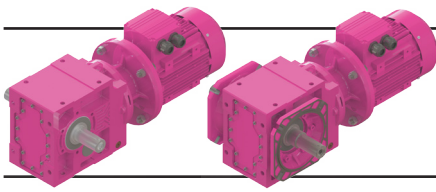

# Ölçü Sayfaları

## Dimension Pages

### Abmessungsseiten

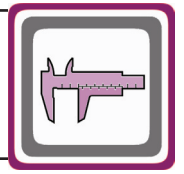

-Mil ucu çekirme deliği DIN 332 sayfa 2 / Tapped center hole to DIN 332, sheet 2 / Zentrierung mit Gewinde DIN 332, Blatt 2

KV675.04  
KV676.04

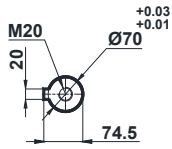
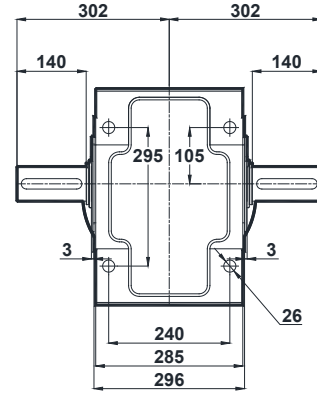
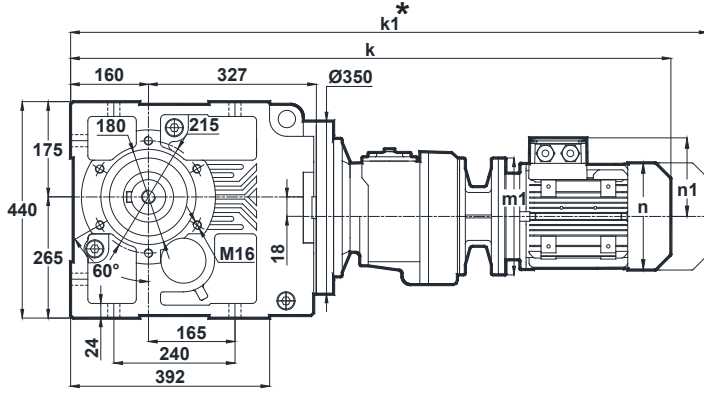

	71/B5	80/B5 80/B14	90S/B5 90S/B14	90L/B5 90L/B14
k	1008	1031	1072	1072
k1	1099	1124	1176.5	1176.5
n / n1	137 / 112	155 / 121	176 / 132	176 / 132
m1 (B5)	160	200	200	200
m1 (B14)	-	120	140	140

**Klemens Pozisyonları**  
Terminal Box Positions  
Klemmenkasten Positionen

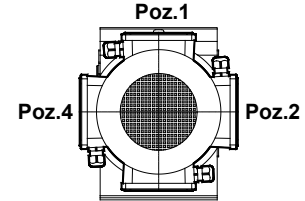

**Poz.3**  
71-80-90  
Tip / Type / Typ

KV675.05  
KV676.05

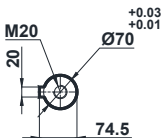
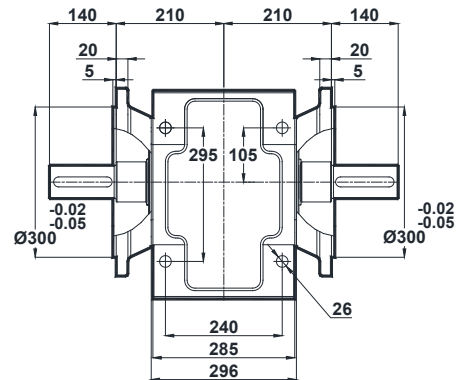
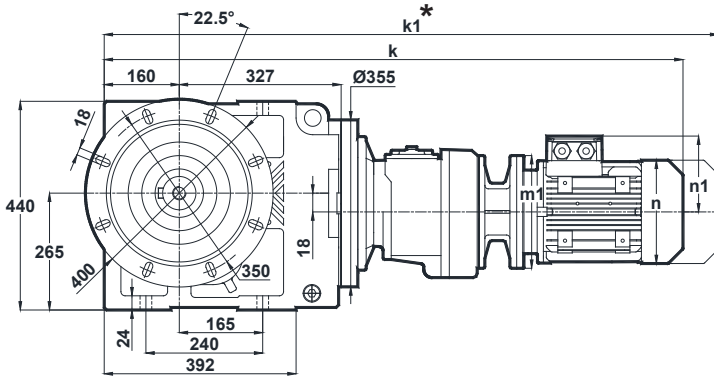

	71/B5	80/B5 80/B14	90S/B5 90S/B14	90L/B5 90L/B14
k	1008	1031	1072	1072
k1	1099	1124	1176.5	1176.5
n / n1	137 / 112	155 / 121	176 / 132	176 / 132
m1 (B5)	160	200	200	200
m1 (B14)	-	120	140	140

\* "k1" Ölçüsü frenli redüktörlere aittir.  
Dimension "k1" is for motors with brake.  
Maße "k1" ist für Bremsenmotoren.





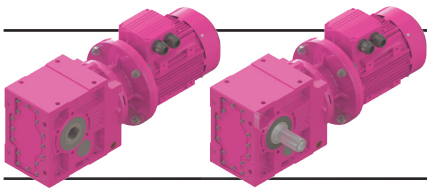

# Ölçü Sayfaları Dimension Pages Abmessungsseiten

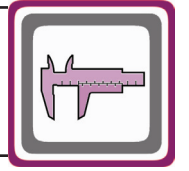

-Mil ucu çektirme deliği DIN 332 sayfa 2 / Tapped center hole to DIN 332, sheet 2 / Zentrierung mit Gewinde DIN 332, Blatt 2

## KV773.00

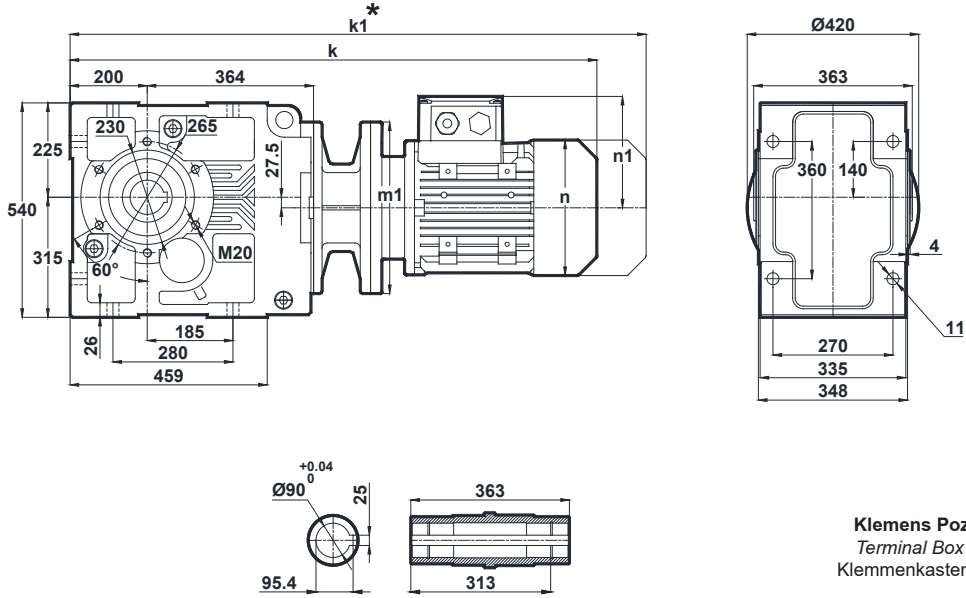

**Klemens Pozisyonları**  
Terminal Box Positions  
Klemmenkasten Positionen

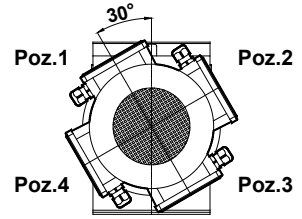

132-160-180-200-225-250  
Tip / Type / Typ

	132S/B5	132M/B5	160M/B5	160L/B5	180M/B5	180L/B5	200L/B5	225S/B5	225M/B5	250M/B5
k	1063	1063	1212	1212	1301	1301	1376	1447	1472	1548
k1	1193	1193	1392	1392	1471.5	1471.5	1562.5	1612	1637	1718.5
n / n1	257 / 179	257 / 179	315 / 219	315 / 219	347 / 234	347 / 234	390 / 275	434 / 285	434 / 285	480 / 322
m1 (B5)	300	300	350	350	350	350	400	450	450	550
m1 (B14)	-	-	-	-	-	-	-	-	-	-

## KV773.01

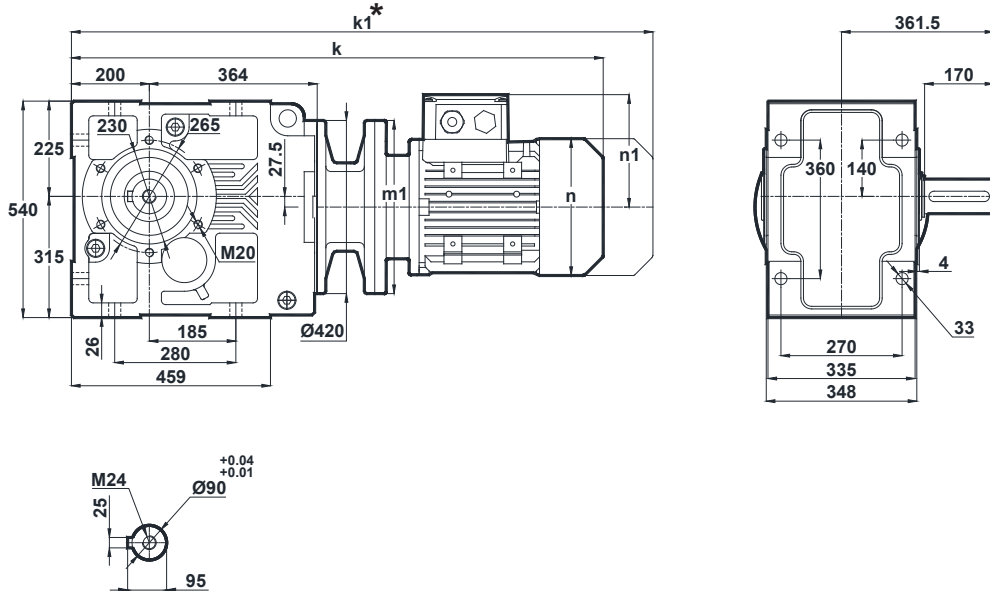

	132S/B5	132M/B5	160M/B5	160L/B5	180M/B5	180L/B5	200L/B5	225S/B5	225M/B5	250M/B5
k	1063	1063	1212	1212	1301	1301	1376	1447	1472	1548
k1	1193	1193	1392	1392	1471.5	1471.5	1562.5	1612	1637	1718.5
n / n1	257 / 179	257 / 179	315 / 219	315 / 219	347 / 234	347 / 234	390 / 275	434 / 285	434 / 285	480 / 322
m1 (B5)	300	300	350	350	350	350	400	450	450	550
m1 (B14)	-	-	-	-	-	-	-	-	-	-

\* "k1" Ölçüsü frenli redüktörlere aittir.  
Dimension "k1" is for motors with brake.  
Maße "k1" ist für Bremsenmotoren.

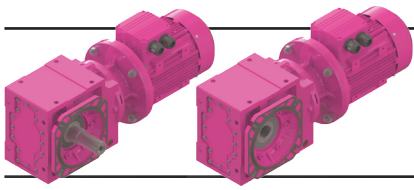

# Ölçü Sayfaları

## Dimension Pages

### Abmessungsseiten



-Mil ucu çektirme deliği DIN 332 sayfa 2 / Tapped center hole to DIN 332, sheet 2 / Zentrierung mit Gewinde DIN 332, Blatt 2

#### KV773.02

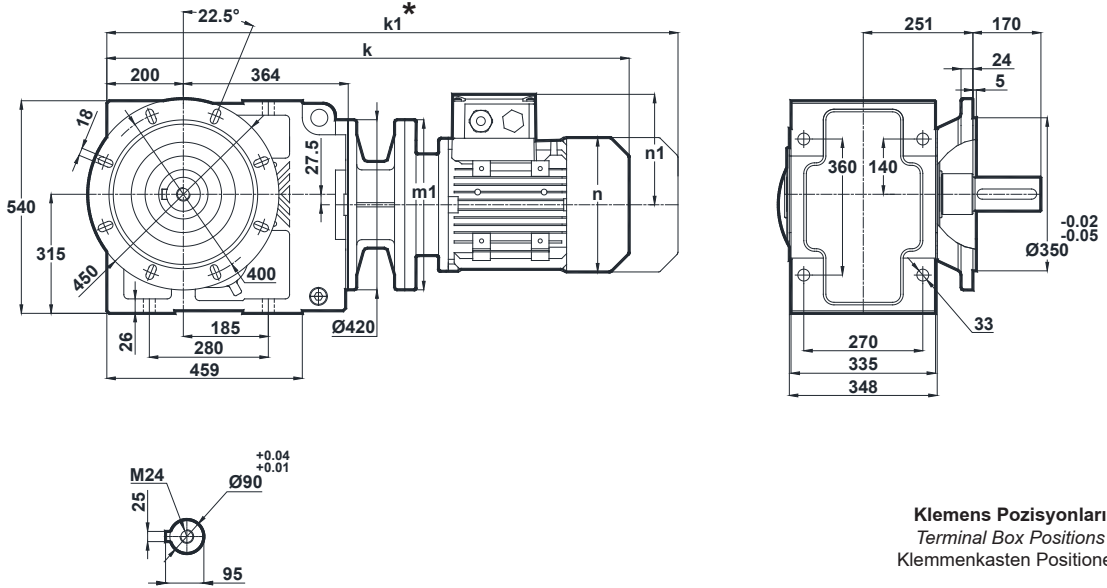

Klemens Pozisyonları  
Terminal Box Positions  
Klemmenkasten Positionen

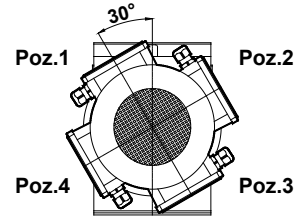

132-160-180-200-225-250  
Tip / Type / Typ

	132S/B5	132M/B5	160M/B5	160L/B5	180M/B5	180L/B5	200L/B5	225S/B5	225M/B5	250M/B5
k	1063	1063	1212	1212	1301	1301	1376	1447	1472	1548
k1	1193	1193	1392	1392	1471.5	1471.5	1562.5	1612	1637	1718.5
n / n1	257 / 179	257 / 179	315 / 219	315 / 219	347 / 234	347 / 234	390 / 275	434 / 285	434 / 285	480 / 322
m1 (B5)	300	300	350	350	350	350	400	450	450	550
m1 (B14)	-	-	-	-	-	-	-	-	-	-

#### KV773.03

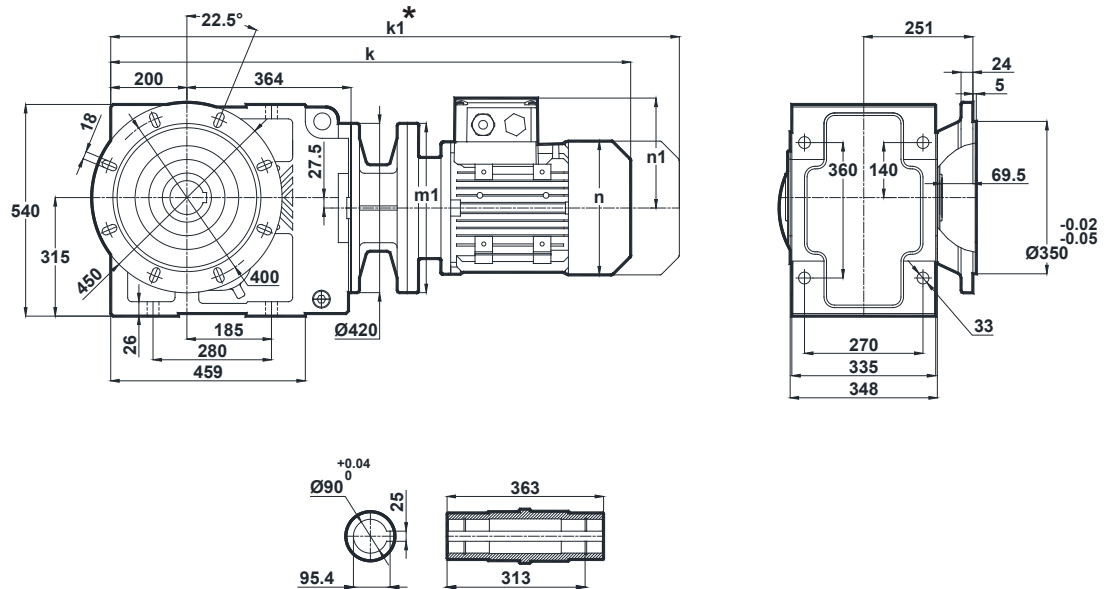

	132S/B5	132M/B5	160M/B5	160L/B5	180M/B5	180L/B5	200L/B5	225S/B5	225M/B5	250M/B5
k	1063	1063	1212	1212	1301	1301	1376	1447	1472	1548
k1	1193	1193	1392	1392	1471.5	1471.5	1562.5	1612	1637	1718.5
n / n1	257 / 179	257 / 179	315 / 219	315 / 219	347 / 234	347 / 234	390 / 275	434 / 285	434 / 285	480 / 322
m1 (B5)	300	300	350	350	350	350	400	450	450	550
m1 (B14)	-	-	-	-	-	-	-	-	-	-

\* " k1 " Ölçüsü frenli redüktörlere aittir.  
Dimension " k1 " is for motors with brake.  
Maße " k1 " ist für Bremsenmotoren.



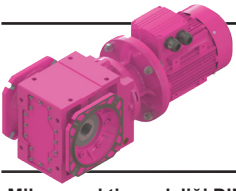

# Ölçü Sayfaları Dimension Pages Abmessungenseiten

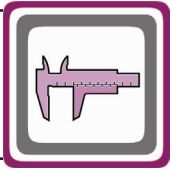

-Mil ucu çektirme deliği DIN 332 sayfa 2 / Tapped center hole to DIN 332, sheet 2 / Zentrierung mit Gewinde DIN 332, Blatt 2

KV773.08

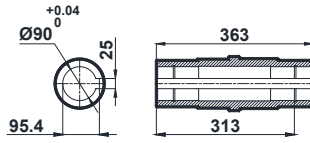
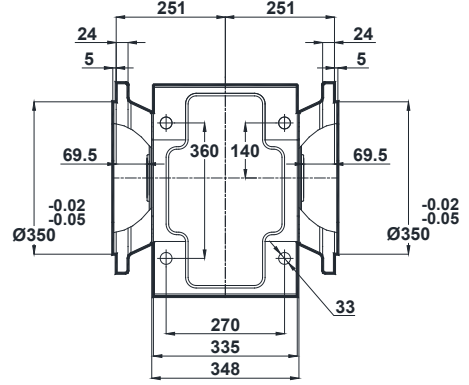
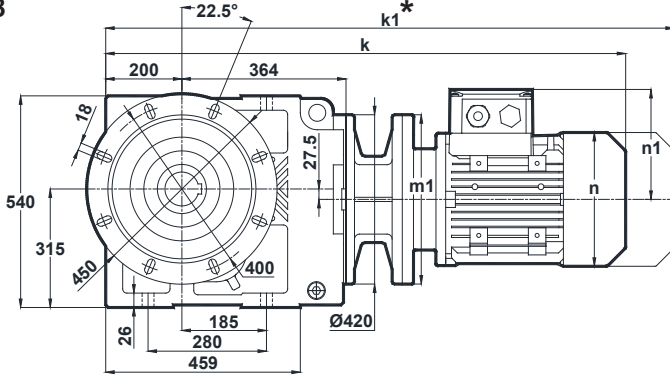

Klemens Pozisyonları  
Terminal Box Positions  
Klemmenkasten Positionen

	132S/B5	132M/B5	160M/B5	160L/B5	180M/B5	180L/B5	200L/B5	225S/B5	225M/B5	250M/B5
k	1063	1063	1212	1212	1301	1301	1376	1447	1472	1548
k1	1193	1193	1392	1392	1471.5	1471.5	1562.5	1612	1637	1718.5
n / n1	257 / 179	257 / 179	315 / 219	315 / 219	347 / 234	347 / 234	390 / 275	434 / 285	434 / 285	480 / 322
m1 (B5)	300	300	350	350	350	350	400	450	450	550
m1 (B14)	-	-	-	-	-	-	-	-	-	-

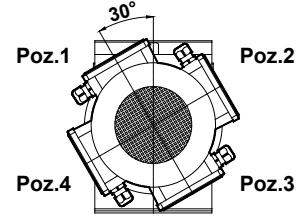

132-160-180-200-225-250  
Tip / Type / Typ

\* "k1" Ölçüsü frenli redüktörlere aittir.  
Dimension "k1" is for motors with brake.  
Maße "k1" ist für Bremsenmotoren.

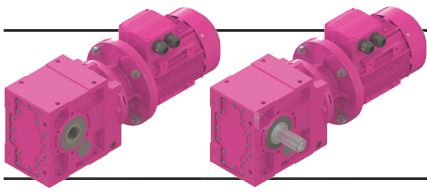

# Ölçü Sayfaları

## Dimension Pages

### Abmessungsseiten

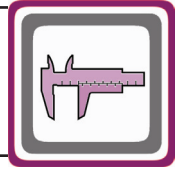

-Mil ucu çektirme deliği DIN 332 sayfa 2 / Tapped center hole to DIN 332, sheet 2 / Zentrierung mit Gewinde DIN 332, Blatt 2

#### KV774.00

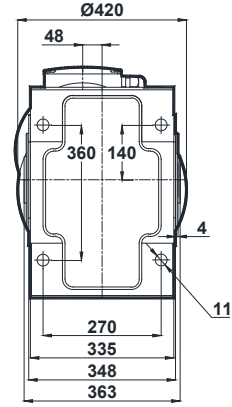
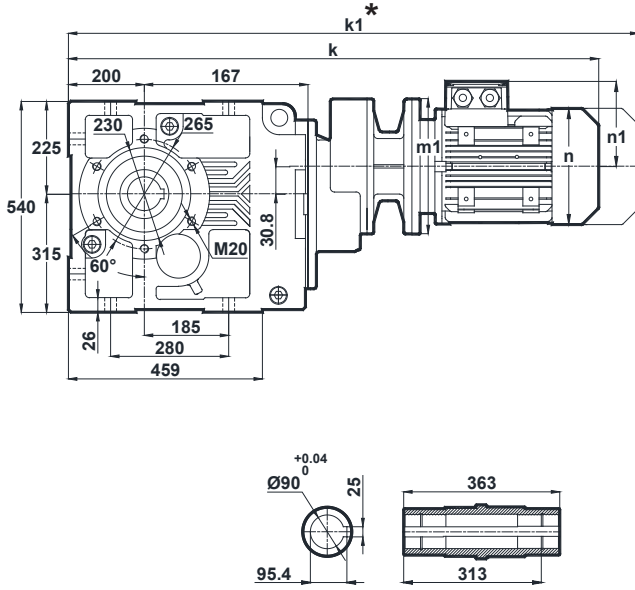

**Klemens Pozisyonları**  
Terminal Box Positions  
Klemmenkasten Positionen

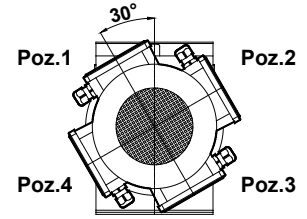

90-100-112-132  
Tip / Type / Typ

	90S/B5 90S/B14	90L/B5 90L/B14	100L/B5 100L/B14	112M/B5 112M/B14	132S/B5 132S/B14	132M/B5 132M/B14
k	998	998	1052	1072	1175	1175
k1	1102.5	1102.5	1171.5	1176.5	1305	1305
n / n1	176 / 132	176 / 132	193 / 147	215 / 158	257 / 179	257 / 179
m1 (B5)	200	200	250	250	300	300
m1 (B14)	140	140	160	160	200	200

#### KV774.01

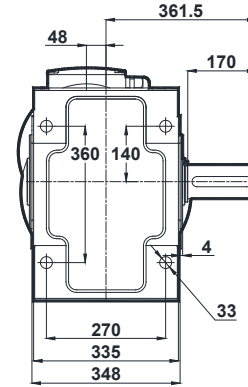
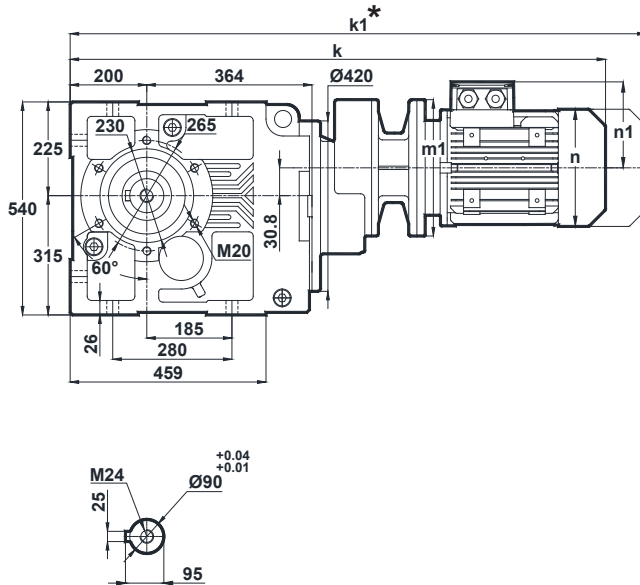

	90S/B5 90S/B14	90L/B5 90L/B14	100L/B5 100L/B14	112M/B5 112M/B14	132S/B5 132S/B14	132M/B5 132M/B14
k	998	998	1052	1072	1175	1175
k1	1102.5	1102.5	1171.5	1176.5	1305	1305
n / n1	176 / 132	176 / 132	193 / 147	215 / 158	257 / 179	257 / 179
m1 (B5)	200	200	250	250	300	300
m1 (B14)	140	140	160	160	200	200

\* "k1" Ölçüsü frenli redüktörlere aittir.  
Dimension "k1" is for motors with brake.  
Maße "k1" ist für Bremsenmotoren.

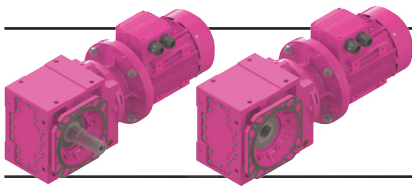

# Ölçü Sayfaları

## Dimension Pages

### Abmessungsseiten

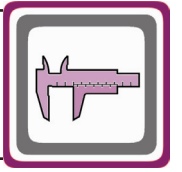

-Mil ucu çekirme deliği DIN 332 sayfa 2 / Tapped center hole to DIN 332, sheet 2 / Zentrierung mit Gewinde DIN 332, Blatt 2

#### KV774.02

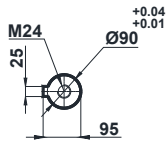
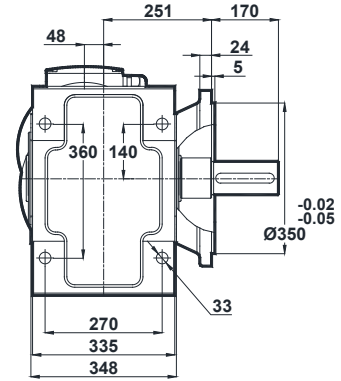
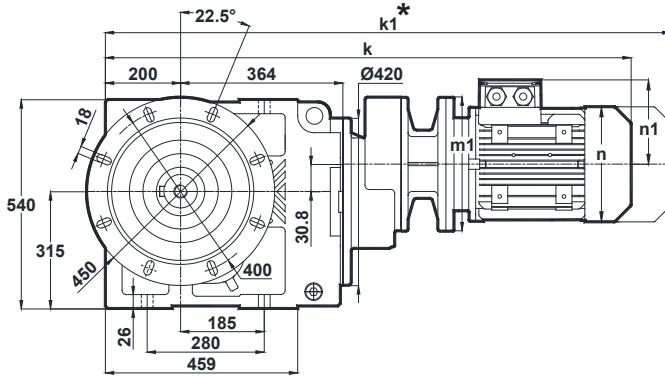

**Klemens Pozisyonları**  
Terminal Box Positions  
Klemmenkasten Positionen

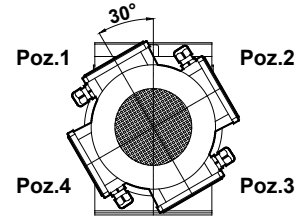

90-100-112-132  
Tip / Type / Typ

	90S/B5 90S/B14	90L/B5 90L/B14	100L/B5 100L/B14	112M/B5 112M/B14	132S/B5 132S/B14	132M/B5 132M/B14
k	998	998	1052	1072	1175	1175
k1	1102.5	1102.5	1171.5	1176.5	1305	1305
n / n1	176 / 132	176 / 132	193 / 147	215 / 158	257 / 179	257 / 179
m1 (B5)	200	200	250	250	300	300
m1 (B14)	140	140	160	160	200	200

#### KV774.03

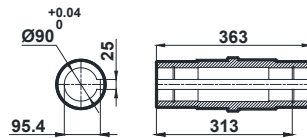
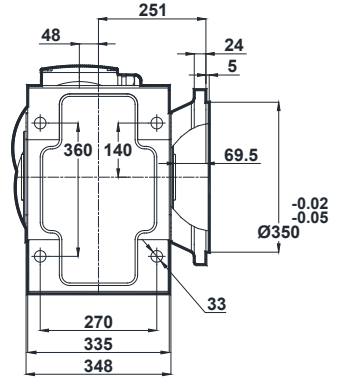
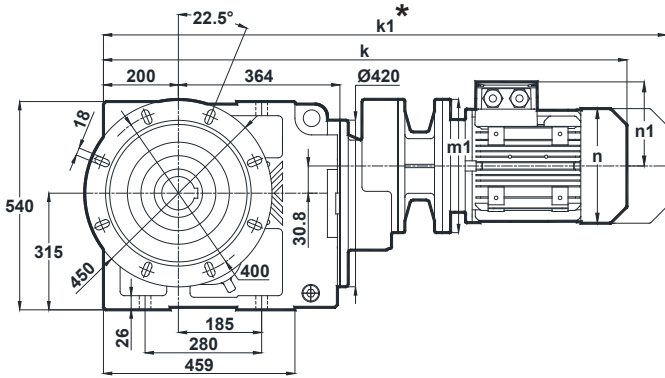

	90S/B5 90S/B14	90L/B5 90L/B14	100L/B5 100L/B14	112M/B5 112M/B14	132S/B5 132S/B14	132M/B5 132M/B14
k	998	998	1052	1072	1175	1175
k1	1102.5	1102.5	1171.5	1176.5	1305	1305
n / n1	176 / 132	176 / 132	193 / 147	215 / 158	257 / 179	257 / 179
m1 (B5)	200	200	250	250	300	300
m1 (B14)	140	140	160	160	200	200

\* " k1 " Ölçüsü frenli redüktörlere aittir.  
Dimension " k1 " is for motors with brake.  
Maße " k1 " ist für Bremsenmotoren.

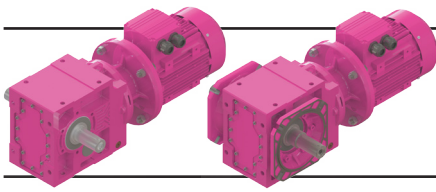

# Ölçü Sayfaları

## Dimension Pages

### Abmessungsseiten

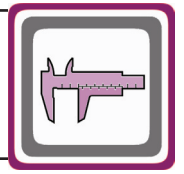

-Mil ucu çektirme deliği DIN 332 sayfa 2 / Tapped center hole to DIN 332, sheet 2 / Zentrierung mit Gewinde DIN 332, Blatt 2

#### KV774.04

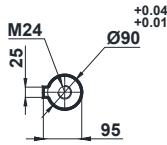
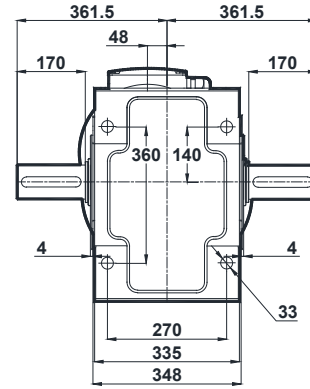
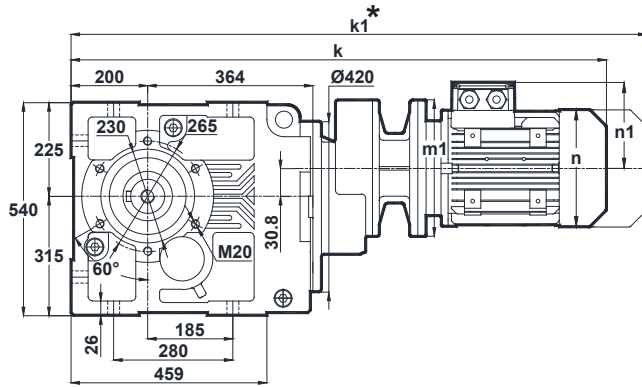

**Klemens Pozisyonları**  
Terminal Box Positions  
Klemmenkasten Positionen

	90S/B5 90S/B14	90L/B5 90L/B14	100L/B5 100L/B14	112M/B5 112M/B14	132S/B5 132S/B14	132M/B5 132M/B14
k	998	998	1052	1072	1175	1175
k1	1102.5	1102.5	1171.5	1176.5	1305	1305
n / n1	176 / 132	176 / 132	193 / 147	215 / 158	257 / 179	257 / 179
m1 (B5)	200	200	250	250	300	300
m1 (B14)	140	140	160	160	200	200

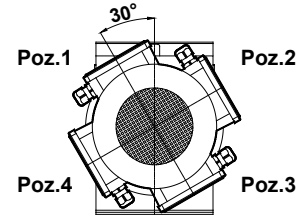

90-100-112-132  
Tip / Type / Typ

#### KV774.05

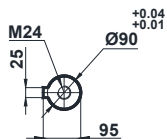
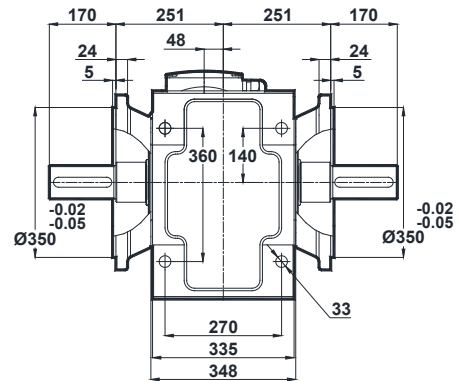
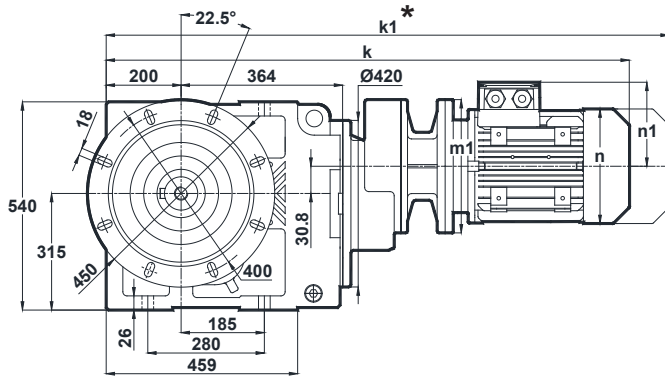

	90S/B5 90S/B14	90L/B5 90L/B14	100L/B5 100L/B14	112M/B5 112M/B14	132S/B5 132S/B14	132M/B5 132M/B14
k	998	998	1052	1072	1175	1175
k1	1102.5	1102.5	1171.5	1176.5	1305	1305
n / n1	176 / 132	176 / 132	193 / 147	215 / 158	257 / 179	257 / 179
m1 (B5)	200	200	250	250	300	300
m1 (B14)	140	140	160	160	200	200

\* "k1" Ölçüsü frenli redüktörlere aittir.  
Dimension "k1" is for motors with brake.  
Maße "k1" ist für Bremsenmotoren.



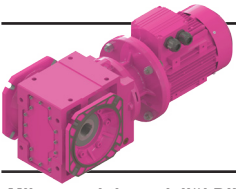

# Ölçü Sayfaları Dimension Pages Abmessungenseiten



-Mil ucu çekirme deliği DIN 332 sayfa 2 / Tapped center hole to DIN 332, sheet 2 / Zentrierung mit Gewinde DIN 332, Blatt 2

KV774.08

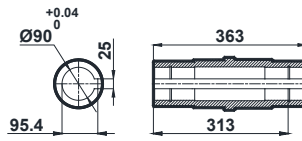
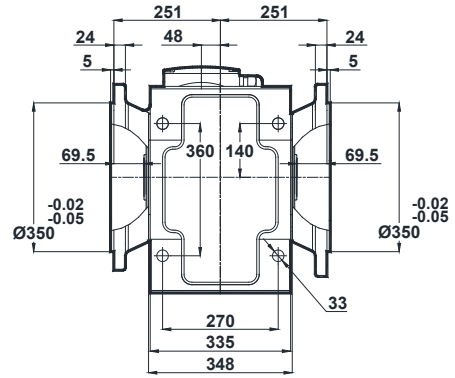
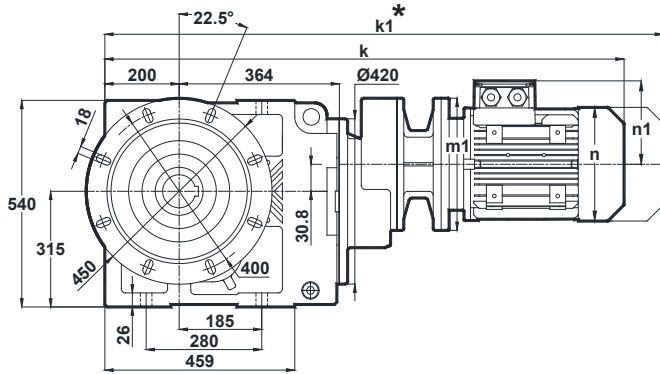

	90S/B5 90S/B14	90L/B5 90L/B14	100L/B5 100L/B14	112M/B5 112M/B14	132S/B5 132S/B14	132M/B5 132M/B14
k	998	998	1052	1072	1175	1175
k1	1102.5	1102.5	1171.5	1176.5	1305	1305
n / n1	176 / 132	176 / 132	193 / 147	215 / 158	257 / 179	257 / 179
m1 (B5)	200	200	250	250	300	300
m1 (B14)	140	140	160	160	200	200

Klemens Pozisyonları  
Terminal Box Positions  
Klemmenkasten Positionen

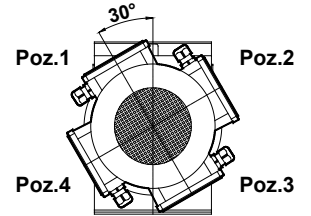

90-100-112-132  
Tip / Type / Typ

\* "k1" Ölçüsü frenli redüktörlere aittir.  
Dimension "k1" is for motors with brake.  
Maße "k1" ist für Bremsenmotoren.

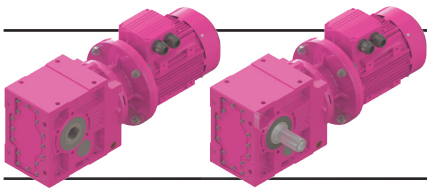

# Ölçü Sayfaları Dimension Pages Abmessungsseiten

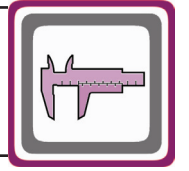

-Mil ucu çektirme deliği DIN 332 sayfa 2 / Tapped center hole to DIN 332, sheet 2 / Zentrierung mit Gewinde DIN 332, Blatt 2

KV775.00  
KV776.00

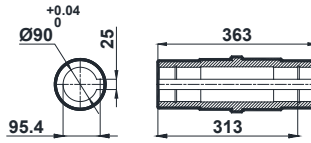
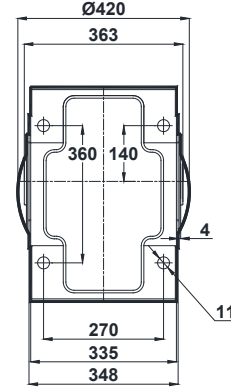
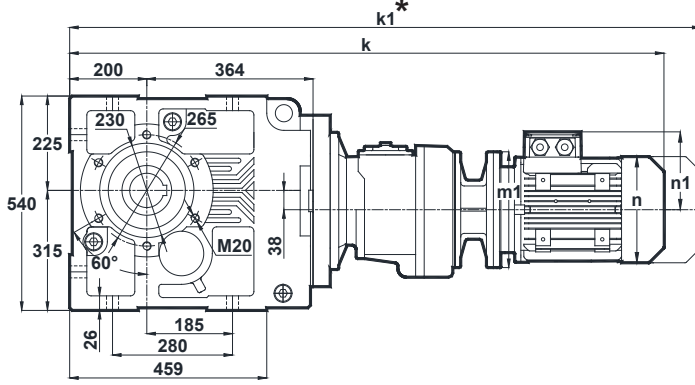

**Klemens Pozisyonları**  
Terminal Box Positions  
Klemmenkasten Positionen

	71/B5	80/B5 80/B14	90S/B5 90S/B14	90L/B5 90L/B14	100L/B5 100L/B14
k	1085	1108	1149	1149	1201
k1	1176	1201	1253.5	1253.5	1320.5
n / n1	137 / 112	155 / 121	176 / 132	176 / 132	193 / 147
m1 (B5)	160	200	200	200	250
m1 (B14)	-	120	140	140	160

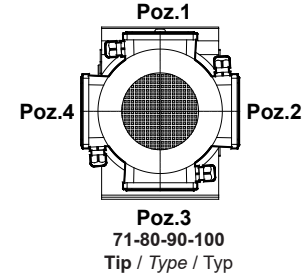

KV775.01  
KV776.01

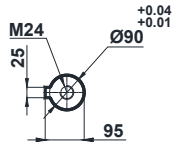
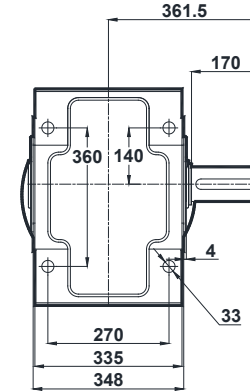
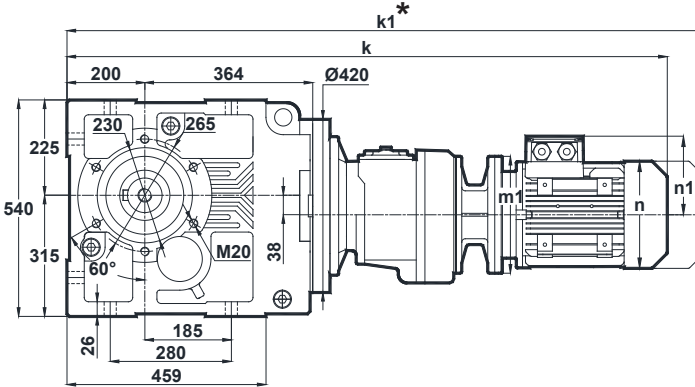

	71/B5	80/B5 80/B14	90S/B5 90S/B14	90L/B5 90L/B14	100L/B5 100L/B14
k	1085	1108	1149	1149	1201
k1	1176	1201	1253.5	1253.5	1320.5
n / n1	137 / 112	155 / 121	176 / 132	176 / 132	193 / 147
m1 (B5)	160	200	200	200	250
m1 (B14)	-	120	140	140	160

\* " k1 " Ölçüsü frenli redüktörlere aittir.  
Dimension " k1 " is for motors with brake.  
Maße " k1 " ist für Bremsmotoren.

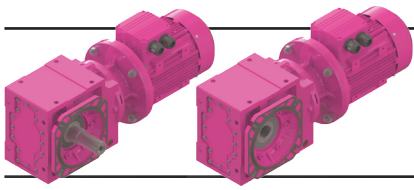

# Ölçü Sayfaları

## Dimension Pages

### Abmessungsseiten

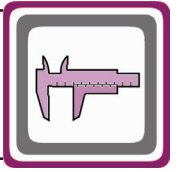

-Mil ucu çektirme deliği DIN 332 sayfa 2 / Tapped center hole to DIN 332, sheet 2 / Zentrierung mit Gewinde DIN 332, Blatt 2

KV775.02  
KV776.02

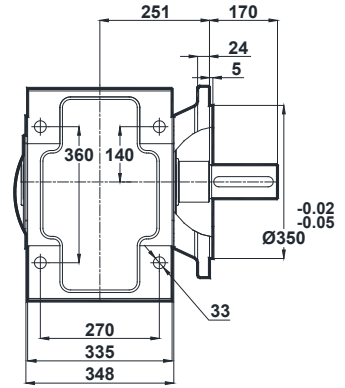
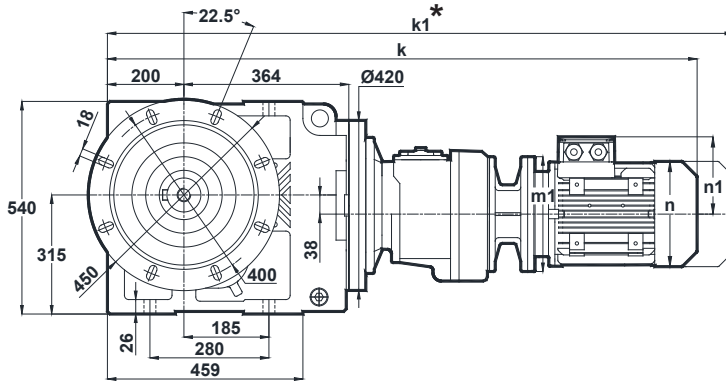

Klemens Pozisyonları  
Terminal Box Positions  
Klemmenkasten Positionen

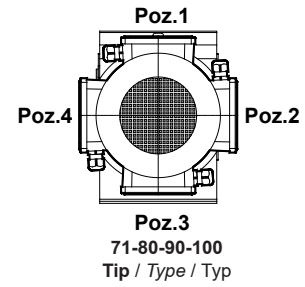

	71/B5	80/B5 80/B14	90S/B5 90S/B14	90L/B5 90L/B14	100L/B5 100L/B14
k	1085	1108	1149	1149	1201
k1	1176	1201	1253.5	1253.5	1320.5
n / n1	137 / 112	155 / 121	176 / 132	176 / 132	193 / 147
m1 (B5)	160	200	200	200	250
m1 (B14)	-	120	140	140	160

KV775.03  
KV776.03

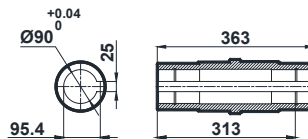
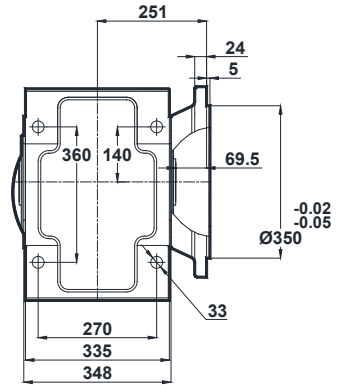
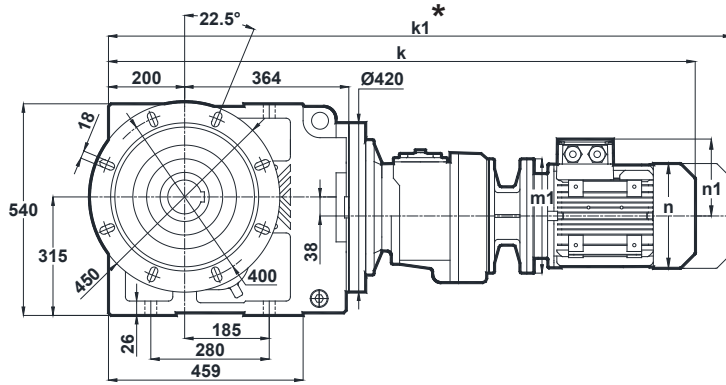

	71/B5	80/B5 80/B14	90S/B5 90S/B14	90L/B5 90L/B14	100L/B5 100L/B14
k	1085	1108	1149	1149	1201
k1	1176	1201	1253.5	1253.5	1320.5
n / n1	137 / 112	155 / 121	176 / 132	176 / 132	193 / 147
m1 (B5)	160	200	200	200	250
m1 (B14)	-	120	140	140	160

\* " k1 " Ölçüsü frenli redüktörlere aittir.  
Dimension " k1 " is for motors with brake.  
Maße " k1 " ist für Bremsenmotoren.

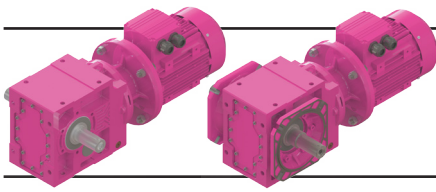

# Ölçü Sayfaları

## Dimension Pages

### Abmessungsseiten

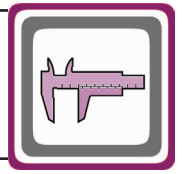

-Mil ucu çekirme deliği DIN 332 sayfa 2 / Tapped center hole to DIN 332, sheet 2 / Zentrierung mit Gewinde DIN 332, Blatt 2

KV775.04  
KV776.04

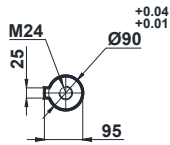
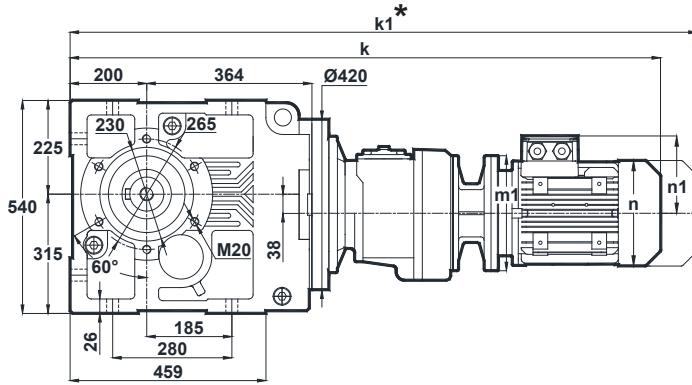

	71/B5	80/B5 80/B14	90S/B5 90S/B14	90L/B5 90L/B14	100L/B5 100L/B14
k	1085	1108	1149	1149	1201
k1	1176	1201	1253.5	1253.5	1320.5
n / n1	137 / 112	155 / 121	176 / 132	176 / 132	193 / 147
m1 (B5)	160	200	200	200	250
m1 (B14)	-	120	140	140	160

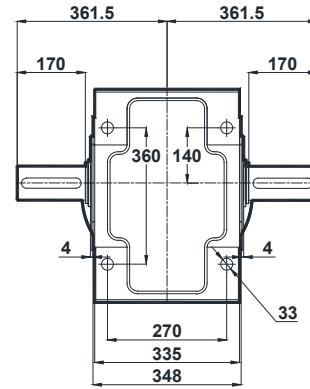

Klemens Pozisyonları  
Terminal Box Positions  
Klemmenkasten Positionen

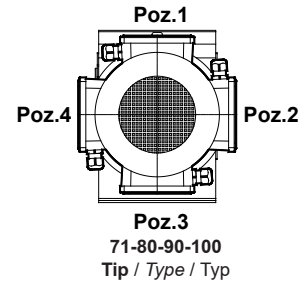

KV775.05  
KV776.05

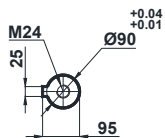
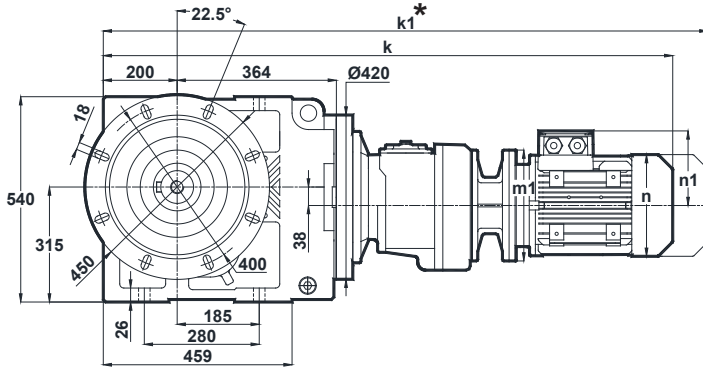

	71/B5	80/B5 80/B14	90S/B5 90S/B14	90L/B5 90L/B14	100L/B5 100L/B14
k	1085	1108	1149	1149	1201
k1	1176	1201	1253.5	1253.5	1320.5
n / n1	137 / 112	155 / 121	176 / 132	176 / 132	193 / 147
m1 (B5)	160	200	200	200	250
m1 (B14)	-	120	140	140	160

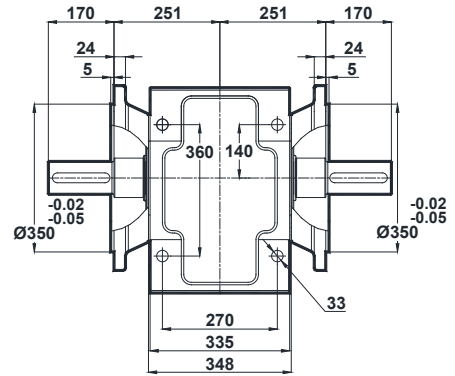

\* "k1" Ölçüsü frenli redüktörlere aittir.  
Dimension "k1" is for motors with brake.  
Maße "k1" ist für Bremsenmotoren.

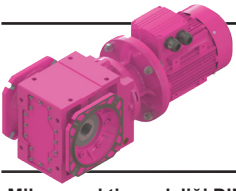

# Ölçü Sayfaları Dimension Pages Abmessungenseiten

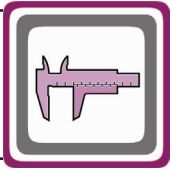

-Mil ucu çekirme deliği DIN 332 sayfa 2 / Tapped center hole to DIN 332, sheet 2 / Zentrierung mit Gewinde DIN 332, Blatt 2

KV775.08  
KV776.08

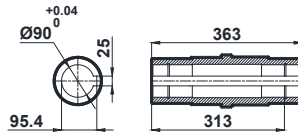
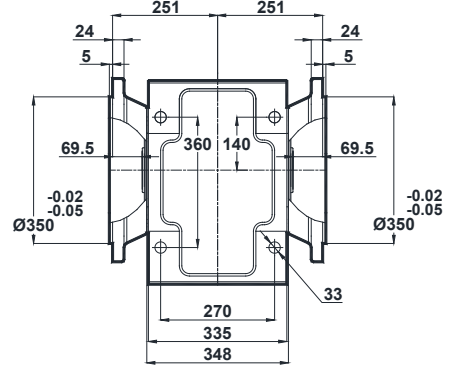
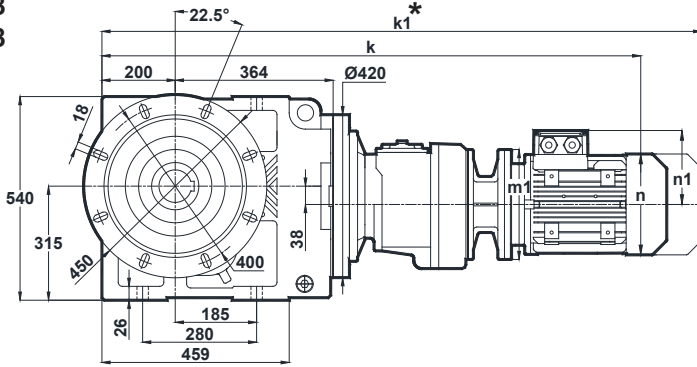

Klemens Pozisyonları  
Terminal Box Positions  
Klemmenkasten Positionen

	71/B5	80/B5 80/B14	90S/B5 90S/B14	90L/B5 90L/B14	100L/B5 100L/B14
k	1085	1108	1149	1149	1201
k1	1176	1201	1253.5	1253.5	1320.5
n / n1	137 / 112	155 / 121	176 / 132	176 / 132	193 / 147
m1 (B5)	160	200	200	200	250
m1 (B14)	-	120	140	140	160

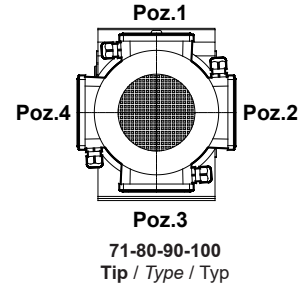

\* "k1" Ölçüsü frenli redüktörlere aittir.  
Dimension "k1" is for motors with brake.  
Maße "k1" ist für Bremsenmotoren.

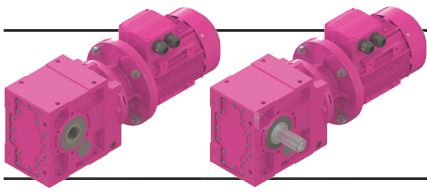

# Ölçü Sayfaları

## Dimension Pages

### Abmessungsseiten

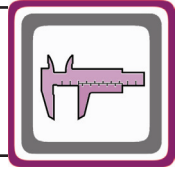

-Mil ucu çektirme deliği DIN 332 sayfa 2 / Tapped center hole to DIN 332, sheet 2 / Zentrierung mit Gewinde DIN 332, Blatt 2

#### KV873.00

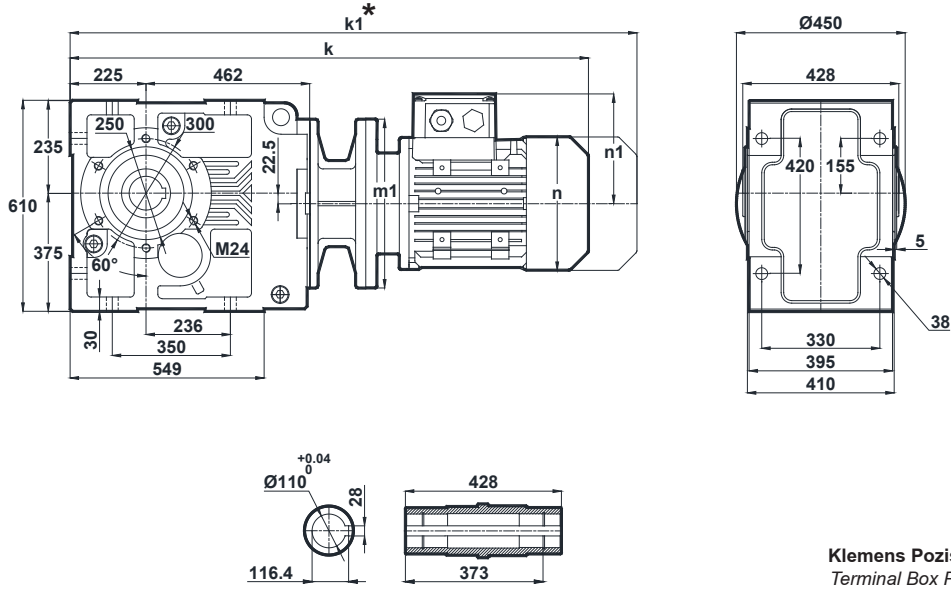

**Klemens Pozisyonları**  
Terminal Box Positions  
Klemmenkasten Positionen

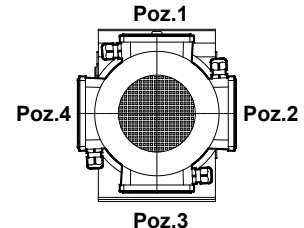

160-180-200-225-250-280  
Tip / Type / Typ

	160M/B5	160L/B5	180M/B5	180L/B5	200L/B5	225S/B5	225M/B5	250M/B5	280S/B5	280M/B5
k	1400	1400	1489	1489	1542	1560	1585	1661	1723	1723
k1	1580	1580	1659.5	1659.5	1728.5	1725	1750	1831.5	1896	1902
n / n1	315 / 219	315 / 219	347 / 234	347 / 234	390 / 275	434 / 285	434 / 285	480 / 322	544 / 350	544 / 350
m1 (B5)	350	350	350	350	400	450	450	550	550	550
m1 (B14)	-	-	-	-	-	-	-	-	-	-

#### KV873.01

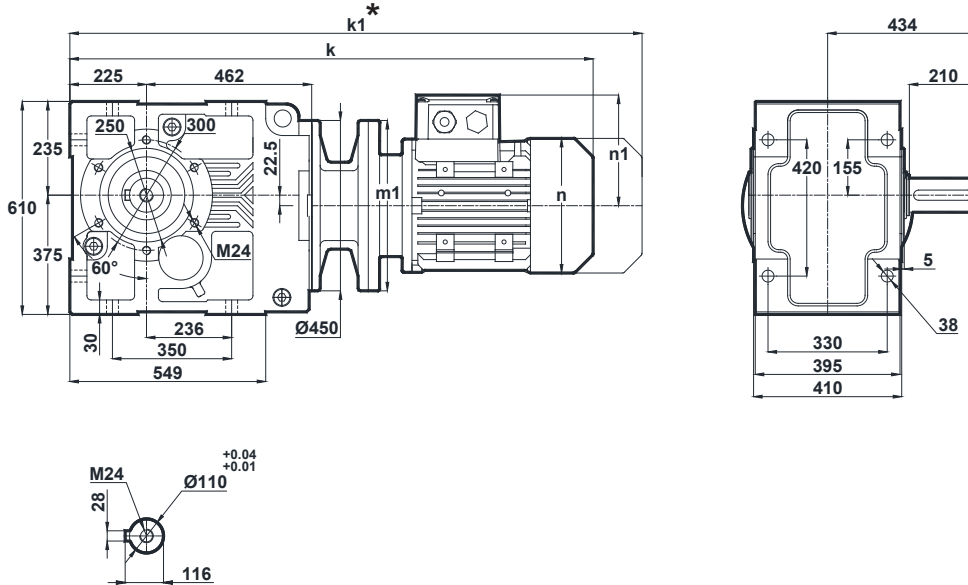

	160M/B5	160L/B5	180M/B5	180L/B5	200L/B5	225S/B5	225M/B5	250M/B5	280S/B5	280M/B5
k	1400	1400	1489	1489	1542	1560	1585	1661	1723	1723
k1	1580	1580	1659.5	1659.5	1728.5	1725	1750	1831.5	1896	1902
n / n1	315 / 219	315 / 219	347 / 234	347 / 234	390 / 275	434 / 285	434 / 285	480 / 322	544 / 350	544 / 350
m1 (B5)	350	350	350	350	400	450	450	550	550	550
m1 (B14)	-	-	-	-	-	-	-	-	-	-

\* "k1" Ölçüsü frenli redüktörlere aittir.  
Dimension "k1" is for motors with brake.  
Maße "k1" ist für Bremsenmotoren.

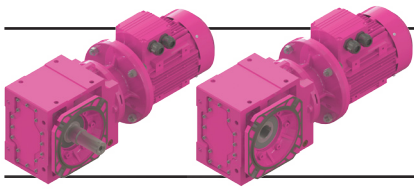

# Ölçü Sayfaları Dimension Pages Abmessungsseiten

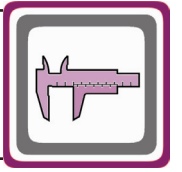

-Mil ucu çektirme deliği DIN 332 sayfa 2 / Tapped center hole to DIN 332, sheet 2 / Zentrierung mit Gewinde DIN 332, Blatt 2

## KV873.02

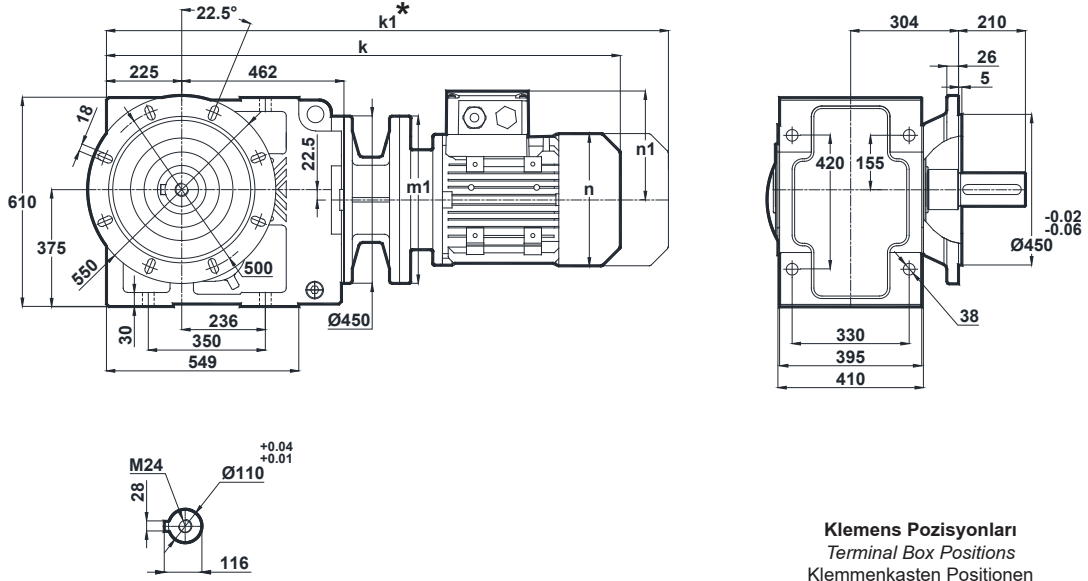

**Klemens Pozisyonları**  
Terminal Box Positions  
Klemmenkasten Positionen

	160M/B5	160L/B5	180M/B5	180L/B5	200L/B5	225S/B5	225M/B5	250M/B5	280S/B5	280M/B5
k	1400	1400	1489	1489	1542	1560	1585	1661	1723	1723
k1	1580	1580	1659.5	1659.5	1728.5	1725	1750	1831.5	1896	1902
n / n1	315 / 219	315 / 219	347 / 234	347 / 234	390 / 275	434 / 285	434 / 285	480 / 322	544 / 350	544 / 350
m1 (B5)	350	350	350	350	400	450	450	550	550	550
m1 (B14)	-	-	-	-	-	-	-	-	-	-

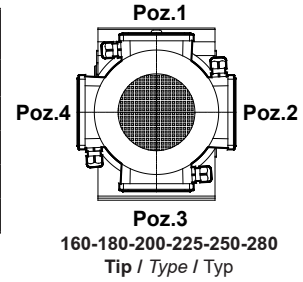

## KV873.03

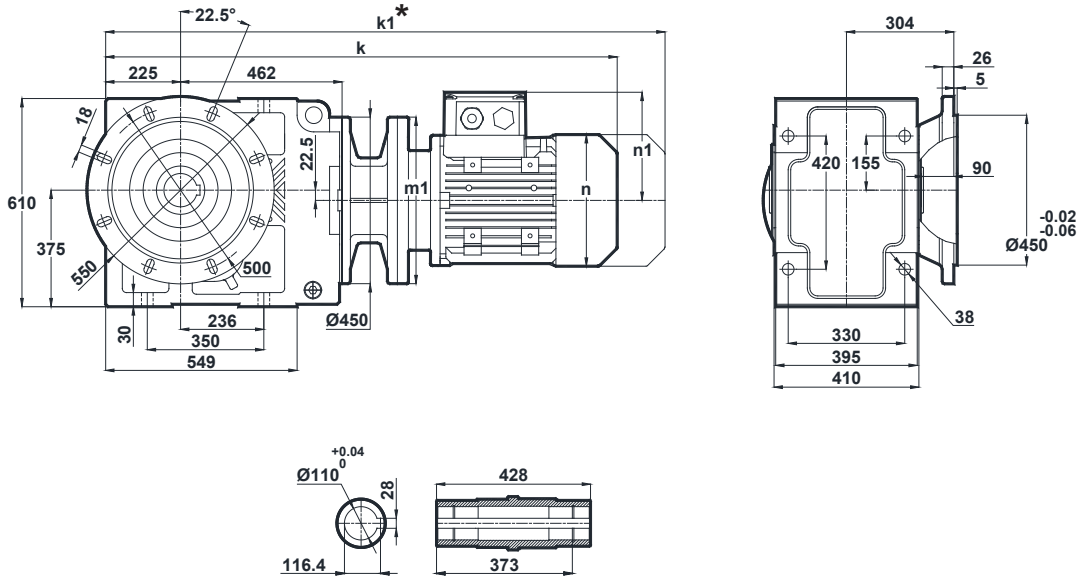

	160M/B5	160L/B5	180M/B5	180L/B5	200L/B5	225S/B5	225M/B5	250M/B5	280S/B5	280M/B5
k	1400	1400	1489	1489	1542	1560	1585	1661	1723	1723
k1	1580	1580	1659.5	1659.5	1728.5	1725	1750	1831.5	1896	1902
n / n1	315 / 219	315 / 219	347 / 234	347 / 234	390 / 275	434 / 285	434 / 285	480 / 322	544 / 350	544 / 350
m1 (B5)	350	350	350	350	400	450	450	550	550	550
m1 (B14)	-	-	-	-	-	-	-	-	-	-

\* "k1" Ölçüsü frenli redüktörlere aittir.  
Dimension "k1" is for motors with brake.  
Maße "k1" ist für Bremsenmotoren.

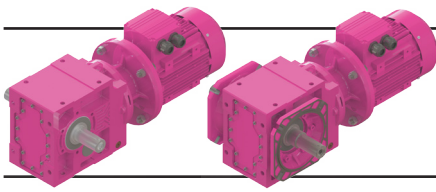

# Ölçü Sayfaları

## Dimension Pages

### Abmessungsseiten

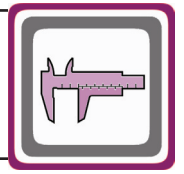

-Mil ucu çektirme deliği DIN 332 sayfa 2 / Tapped center hole to DIN 332, sheet 2 / Zentrierung mit Gewinde DIN 332, Blatt 2

#### KV873.04

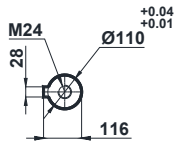
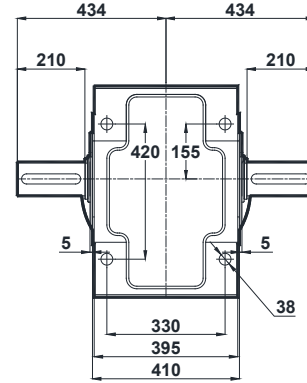
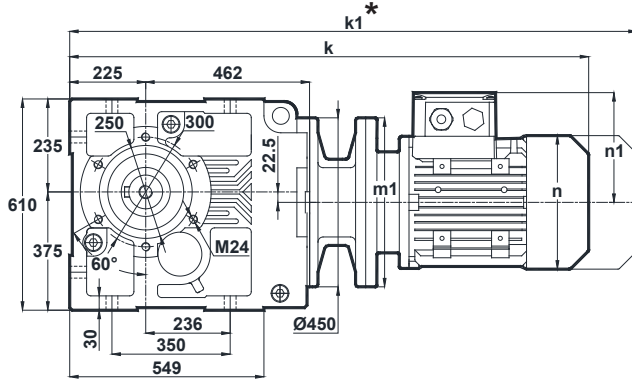

**Klemens Pozisyonları**  
Terminal Box Positions  
Klemmenkasten Positionen

	160M/B5	160L/B5	180M/B5	180L/B5	200L/B5	225S/B5	225M/B5	250M/B5	280S/B5	280M/B5
<b>k</b>	1400	1400	1489	1489	1542	1560	1585	1661	1723	1723
<b>k1</b>	1580	1580	1659.5	1659.5	1728.5	1725	1750	1831.5	1896	1902
<b>n / n1</b>	315 / 219	315 / 219	347 / 234	347 / 234	390 / 275	434 / 285	434 / 285	480 / 322	544 / 350	544 / 350
<b>m1 (B5)</b>	350	350	350	350	400	450	450	550	550	550
<b>m1 (B14)</b>	-	-	-	-	-	-	-	-	-	-

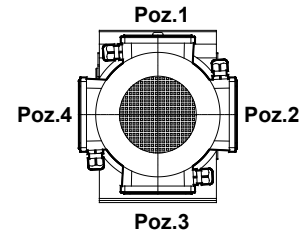

**160-180-200-225-250-280**  
Tip / Type / Typ

#### KV873.05

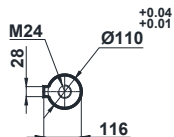
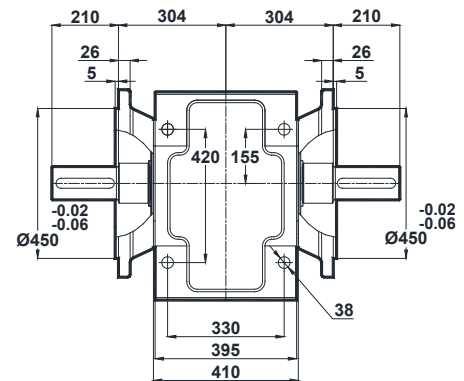
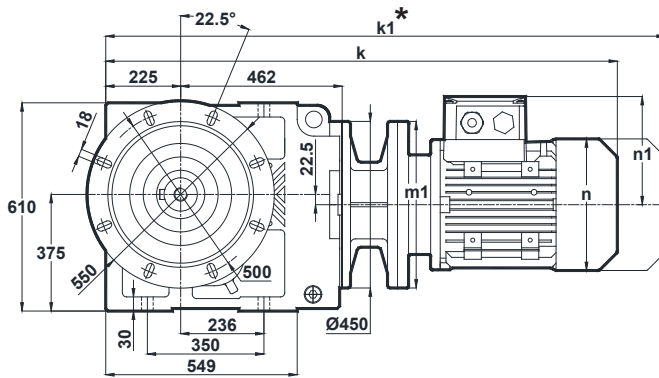

	160M/B5	160L/B5	180M/B5	180L/B5	200L/B5	225S/B5	225M/B5	250M/B5	280S/B5	280M/B5
<b>k</b>	1400	1400	1489	1489	1542	1560	1585	1661	1723	1723
<b>k1</b>	1580	1580	1659.5	1659.5	1728.5	1725	1750	1831.5	1896	1902
<b>n / n1</b>	315 / 219	315 / 219	347 / 234	347 / 234	390 / 275	434 / 285	434 / 285	480 / 322	544 / 350	544 / 350
<b>m1 (B5)</b>	350	350	350	350	400	450	450	550	550	550
<b>m1 (B14)</b>	-	-	-	-	-	-	-	-	-	-

\* "k1" Ölçüsü frenli redüktörlere aittir.  
Dimension "k1" is for motors with brake.  
Maße "k1" ist für Bremsenmotoren.



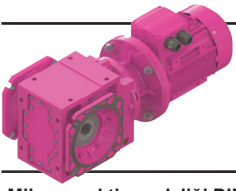

# Ölçü Sayfaları Dimension Pages Abmessungenseiten



-Mil ucu çektirme deliği DIN 332 sayfa 2 / Tapped center hole to DIN 332, sheet 2 / Zentrierung mit Gewinde DIN 332, Blatt 2

KV873.08

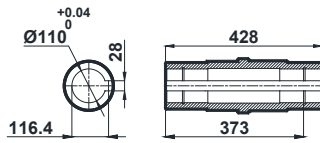
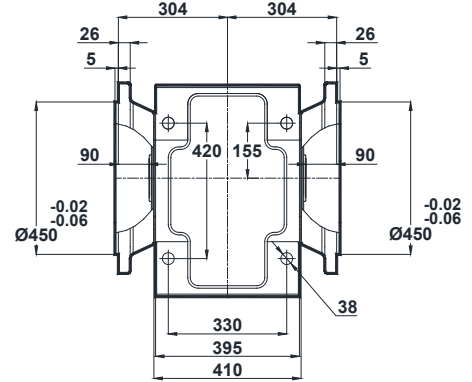
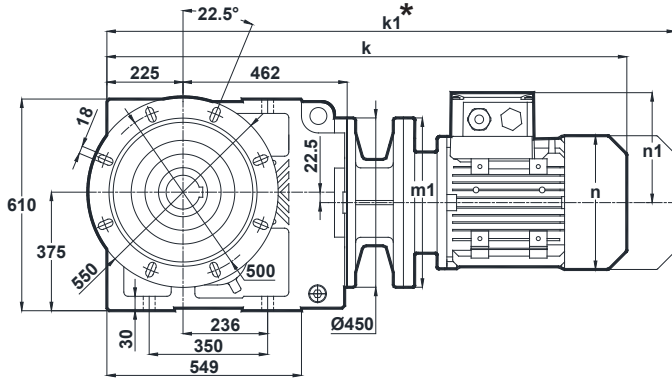

Klemens Pozisyonları  
Terminal Box Positions  
Klemmenkasten Positionen

	160M/B5	160L/B5	180M/B5	180L/B5	200L/B5	225S/B5	225M/B5	250M/B5	280S/B5	280M/B5
k	1400	1400	1489	1489	1542	1560	1585	1661	1723	1723
k1	1580	1580	1659.5	1659.5	1728.5	1725	1750	1831.5	1896	1902
n / n1	315 / 219	315 / 219	347 / 234	347 / 234	390 / 275	434 / 285	434 / 285	480 / 322	544 / 350	544 / 350
m1 (B5)	350	350	350	350	400	450	450	550	550	550
m1 (B14)	-	-	-	-	-	-	-	-	-	-

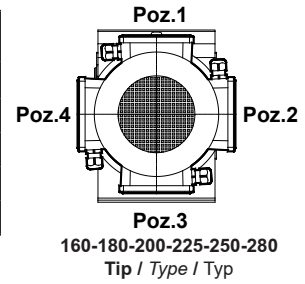

\* " k1 " Ölçüsü frenli redüktörlere aittir.  
Dimension " k1 " is for motors with brake.  
Maße " k1 " ist für Bremsenmotoren.

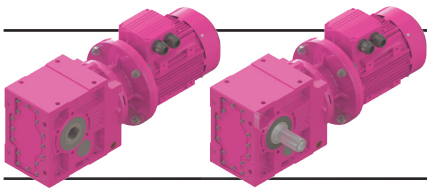

# Ölçü Sayfaları

## Dimension Pages

### Abmessungsseiten

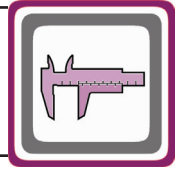

-Mil ucu çekirme deliği DIN 332 sayfa 2 / Tapped center hole to DIN 332, sheet 2 / Zentrierung mit Gewinde DIN 332, Blatt 2

#### KV874.00

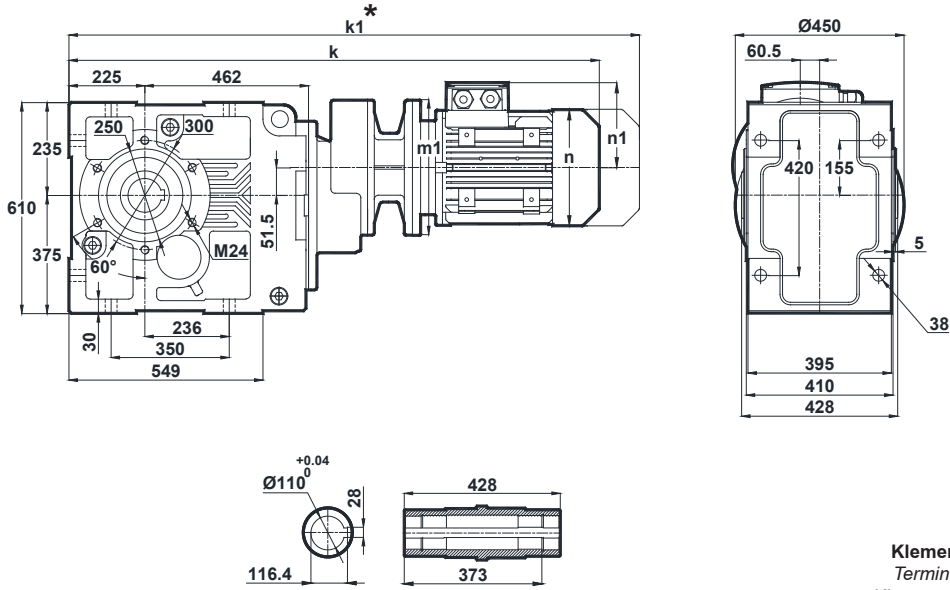

	100L/B5	112M/B5	132S/B5 132S/B14	132M/B5 132M/B14	160M/B5	160L/B5	180M/B5
k	1188	1209	1314	1314	1469	1469	1558
k1	1307.5	1313.5	1444	1444	1649	1649	1728.5
n / n1	193 / 147	215 / 158	257 / 179	257 / 179	315 / 219	315 / 219	347 / 234
m1 (B5)	250	250	300	300	350	350	350
m1 (B14)	-	-	200	200	-	-	-

Klemens Pozisyonları  
Terminal Box Positions  
Klemmenkasten Positionen

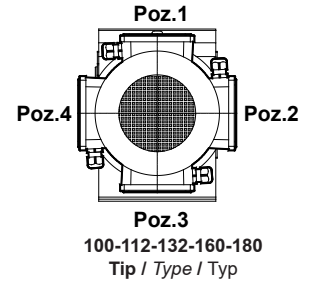

#### KV874.01

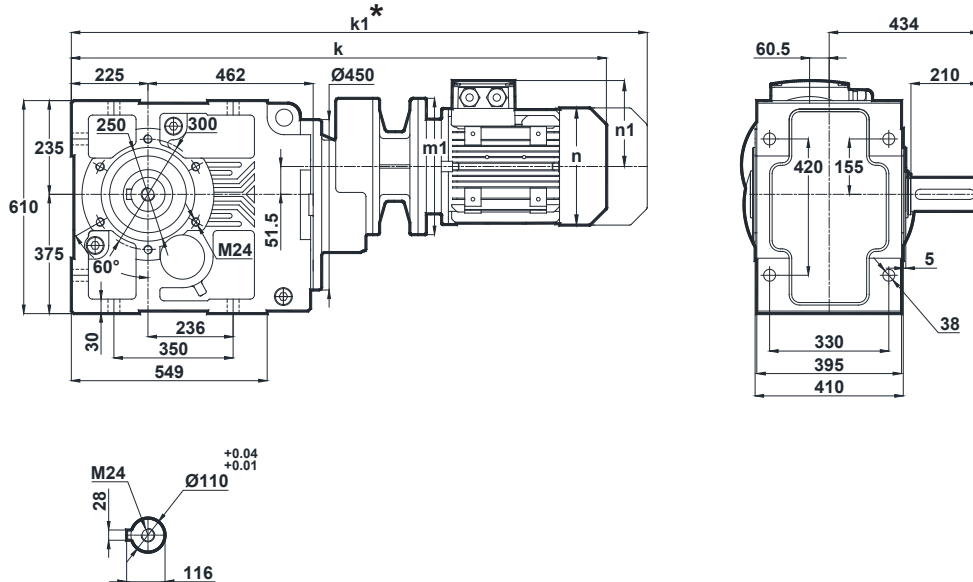

	100L/B5	112M/B5	132S/B5 132S/B14	132M/B5 132M/B14	160M/B5	160L/B5	180M/B5
k	1188	1209	1314	1314	1469	1469	1558
k1	1307.5	1313.5	1444	1444	1649	1649	1728.5
n / n1	193 / 147	215 / 158	257 / 179	257 / 179	315 / 219	315 / 219	347 / 234
m1 (B5)	250	250	300	300	350	350	350
m1 (B14)	-	-	200	200	-	-	-

\* "k1" Ölçüsü frenli redüktörlere aittir.  
Dimension "k1" is for motors with brake.  
Maße "k1" ist für Bremsenmotoren.

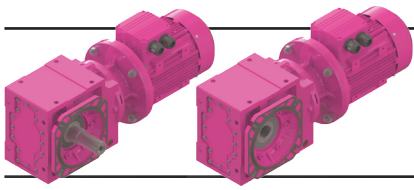

# Ölçü Sayfaları

## Dimension Pages

### Abmessungsseiten



-Mil ucu çektirme deliği DIN 332 sayfa 2 / Tapped center hole to DIN 332, sheet 2 / Zentrierung mit Gewinde DIN 332, Blatt 2

#### KV874.02

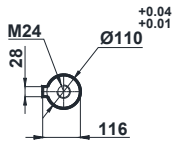
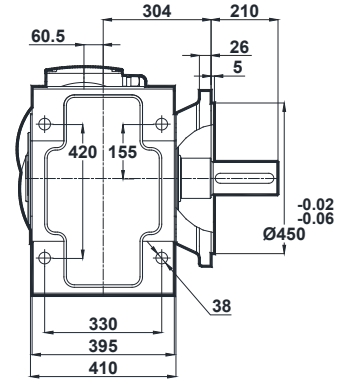
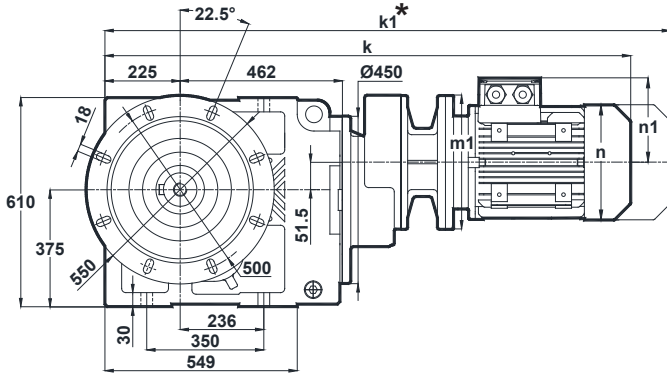

Klemens Pozisyonları  
Terminal Box Positions  
Klemmenkasten Positionen

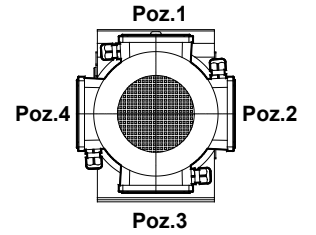

100-112-132-160-180  
Tip / Type / Typ

	100L/B5	112M/B5	132S/B5 132S/B14	132M/B5 132M/B14	160M/B5	160L/B5	180M/B5
k	1188	1209	1314	1314	1469	1469	1558
k1	1307.5	1313.5	1444	1444	1649	1649	1728.5
n / n1	193 / 147	215 / 158	257 / 179	257 / 179	315 / 219	315 / 219	347 / 234
m1 (B5)	250	250	300	300	350	350	350
m1 (B14)	-	-	200	200	-	-	-

#### KV874.03

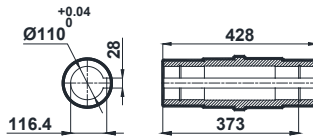
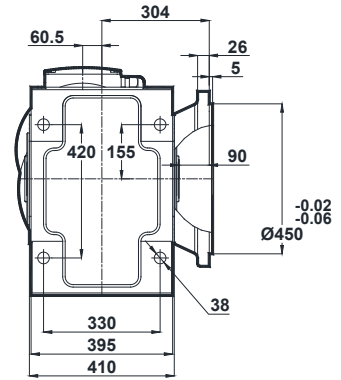
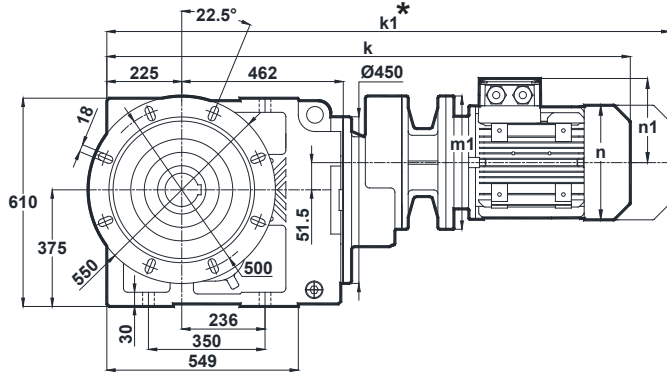

	100L/B5	112M/B5	132S/B5 132S/B14	132M/B5 132M/B14	160M/B5	160L/B5	180M/B5
k	1188	1209	1314	1314	1469	1469	1558
k1	1307.5	1313.5	1444	1444	1649	1649	1728.5
n / n1	193 / 147	215 / 158	257 / 179	257 / 179	315 / 219	315 / 219	347 / 234
m1 (B5)	250	250	300	300	350	350	350
m1 (B14)	-	-	200	200	-	-	-

\* " k1 " Ölçüsü frenli redüktörlere aittir.  
Dimension " k1 " is for motors with brake.  
Maße " k1 " ist für Bremsenmotoren.

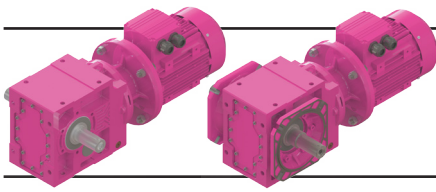

# Ölçü Sayfaları

## Dimension Pages

### Abmessungsseiten

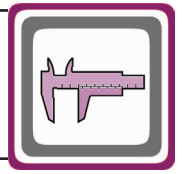

-Mil ucu çektirme deliği DIN 332 sayfa 2 / Tapped center hole to DIN 332, sheet 2 / Zentrierung mit Gewinde DIN 332, Blatt 2

#### KV874.04

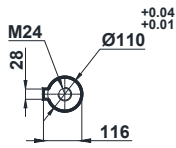
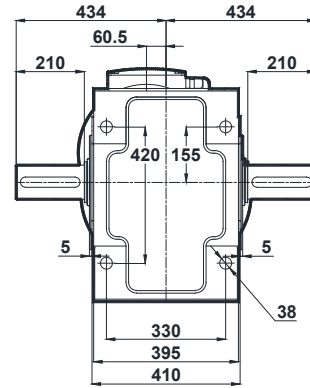
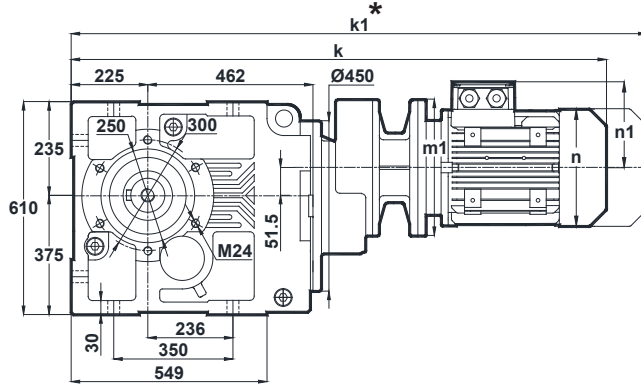

	100L/B5	112M/B5	132S/B5 132S/B14	132M/B5 132M/B14	160M/B5	160L/B5	180M/B5
k	1188	1209	1314	1314	1469	1469	1558
k1	1307.5	1313.5	1444	1444	1649	1649	1728.5
n / n1	193 / 147	215 / 158	257 / 179	257 / 179	315 / 219	315 / 219	347 / 234
m1 (B5)	250	250	300	300	350	350	350
m1 (B14)	-	-	200	200	-	-	-

Klemens Pozisyonları  
Terminal Box Positions  
Klemmenkasten Positionen

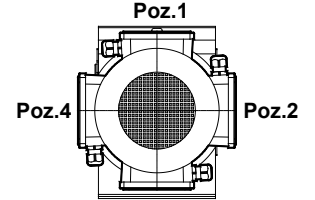

Poz.1  
Poz.2  
Poz.3  
Poz.4  
100-112-132-160-180  
Tip / Type / Typ

#### KV874.05

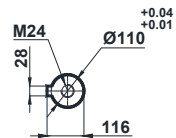
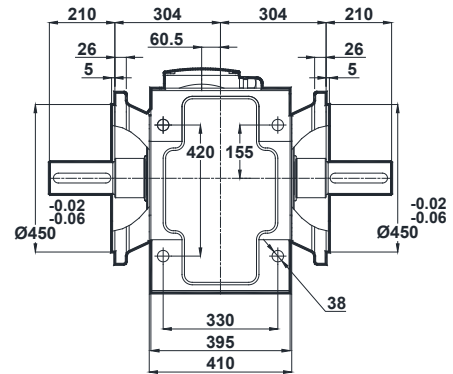
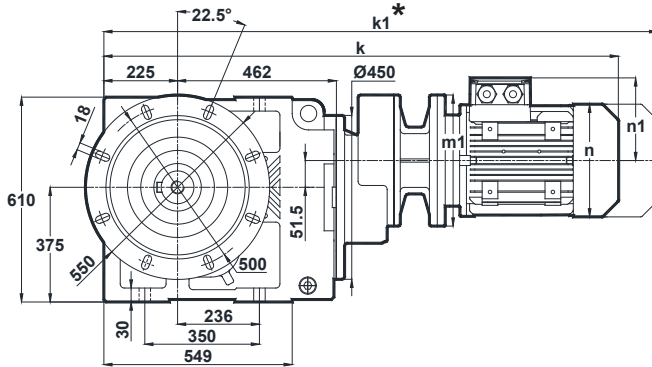

	100L/B5	112M/B5	132S/B5 132S/B14	132M/B5 132M/B14	160M/B5	160L/B5	180M/B5
k	1188	1209	1314	1314	1469	1469	1558
k1	1307.5	1313.5	1444	1444	1649	1649	1728.5
n / n1	193 / 147	215 / 158	257 / 179	257 / 179	315 / 219	315 / 219	347 / 234
m1 (B5)	250	250	300	300	350	350	350
m1 (B14)	-	-	200	200	-	-	-

\* "k1" Ölçüsü frenli redüktörlere aittir.  
Dimension "k1" is for motors with brake.  
Maße "k1" ist für Bremsenmotoren.

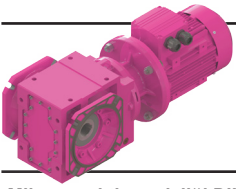

# Ölçü Sayfaları Dimension Pages Abmessungsseiten

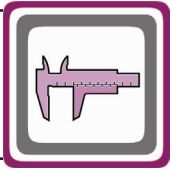

-Mil ucu çektirme deliği DIN 332 sayfa 2 / Tapped center hole to DIN 332, sheet 2 / Zentrierung mit Gewinde DIN 332, Blatt 2

KV874.08

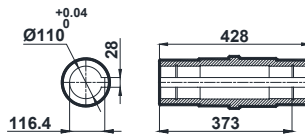
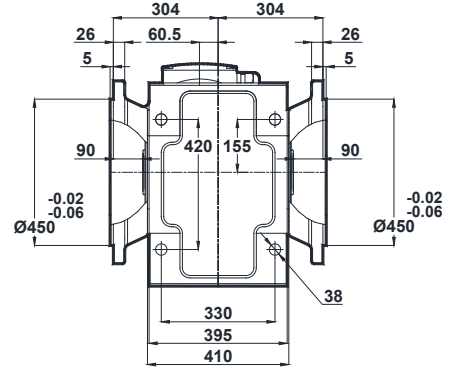
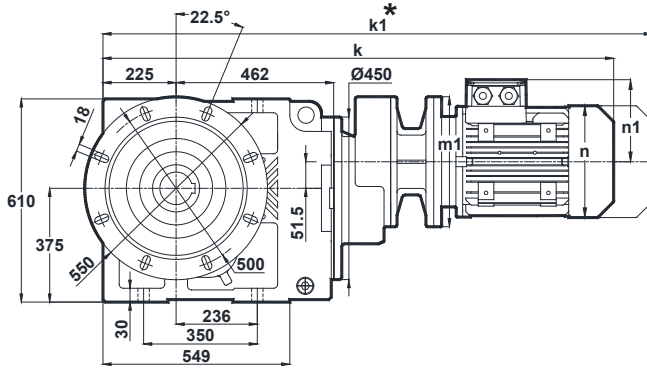

Klemens Pozisyonları  
Terminal Box Positions  
Klemmenkasten Positionen

	100L/B5	112M/B5	132S/B5 132S/B14	132M/B5 132M/B14	160M/B5	160L/B5	180M/B5
k	1188	1209	1314	1314	1469	1469	1558
k1	1307.5	1313.5	1444	1444	1649	1649	1728.5
n / n1	193 / 147	215 / 158	257 / 179	257 / 179	315 / 219	315 / 219	347 / 234
m1 (B5)	250	250	300	300	350	350	350
m1 (B14)	-	-	200	200	-	-	-

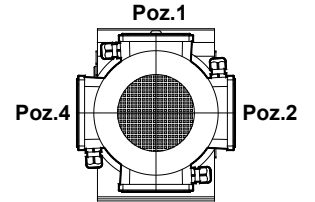

Poz.3  
100-112-132-160-180  
Tip / Type / Typ

\* " k1 " Ölçüsü frenli redüktörlere aittir.  
Dimension " k1 " is for motors with brake.  
Maße " k1 " ist für Bremsenmotoren.

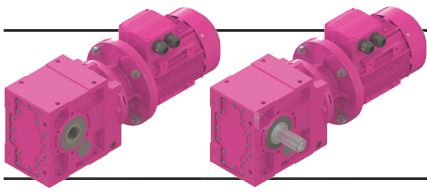

# Ölçü Sayfaları

## Dimension Pages

### Abmessungsseiten

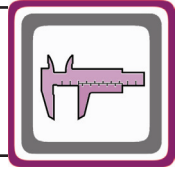

-Mil ucu çektirme deliği DIN 332 sayfa 2 / Tapped center hole to DIN 332, sheet 2 / Zentrierung mit Gewinde DIN 332, Blatt 2

KV875.00  
KV876.00

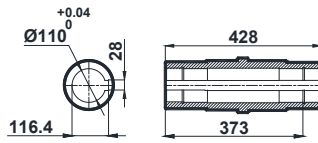
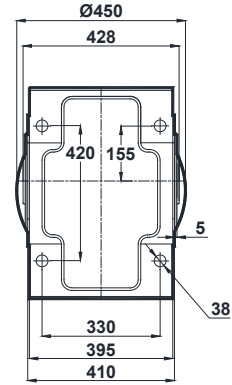
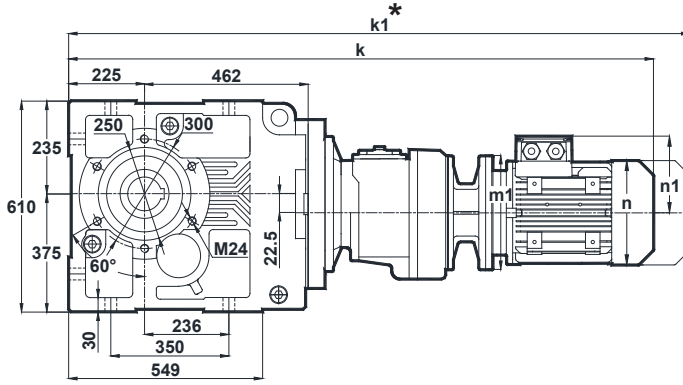

**Klemens Pozisyonları**  
Terminal Box Positions  
Klemmenkasten Positionen

	71/B5	80/B5 80/B14	90S/B5 90S/B14	90L/B5 90L/B14	100L/B5 100L/B14	112M/B5 112M/B14
<b>k</b>	1208	1231	1272	1272	1324	1345
<b>k1</b>	1299	1324	1376.5	1376.5	1443.5	1449.5
<b>n / n1</b>	137 / 112	155 / 121	176 / 132	176 / 132	193 / 147	215 / 158
<b>m1 (B5)</b>	160	200	200	200	250	250
<b>m1 (B14)</b>	-	120	140	140	160	160

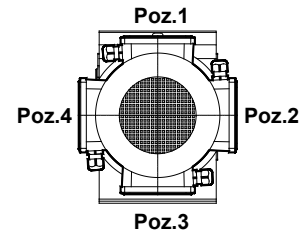

71-80-90-100-112  
Tip / Type / Typ

KV875.01  
KV876.01

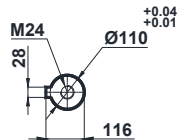
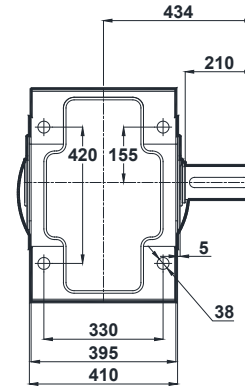
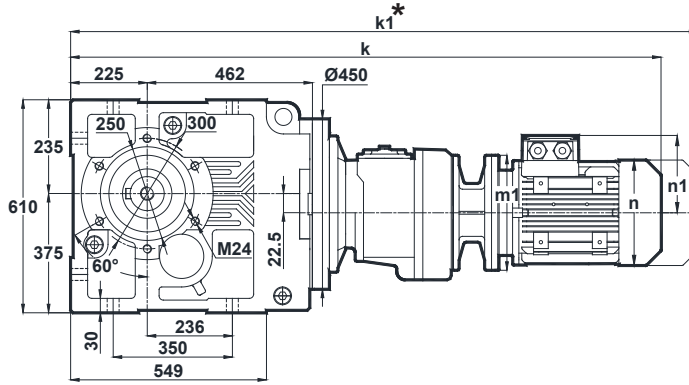

	71/B5	80/B5 80/B14	90S/B5 90S/B14	90L/B5 90L/B14	100L/B5 100L/B14	112M/B5 112M/B14
<b>k</b>	1208	1231	1272	1272	1324	1345
<b>k1</b>	1299	1324	1376.5	1376.5	1443.5	1449.5
<b>n / n1</b>	137 / 112	155 / 121	176 / 132	176 / 132	193 / 147	215 / 158
<b>m1 (B5)</b>	160	200	200	200	250	250
<b>m1 (B14)</b>	-	120	140	140	160	160

\* " k1 " Ölçüsü frenli redüktörlere aittir.  
Dimension " k1 " is for motors with brake.  
Maße " k1 " ist für Bremsmotoren.

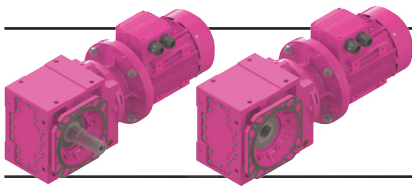

# Ölçü Sayfaları

## Dimension Pages

### Abmessungsseiten

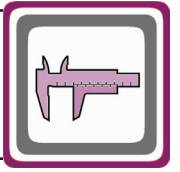

-Mil ucu çektirme deliği DIN 332 sayfa 2 / Tapped center hole to DIN 332, sheet 2 / Zentrierung mit Gewinde DIN 332, Blatt 2

KV875.02  
KV876.02

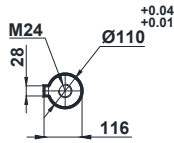
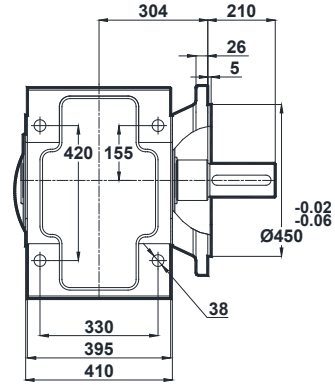
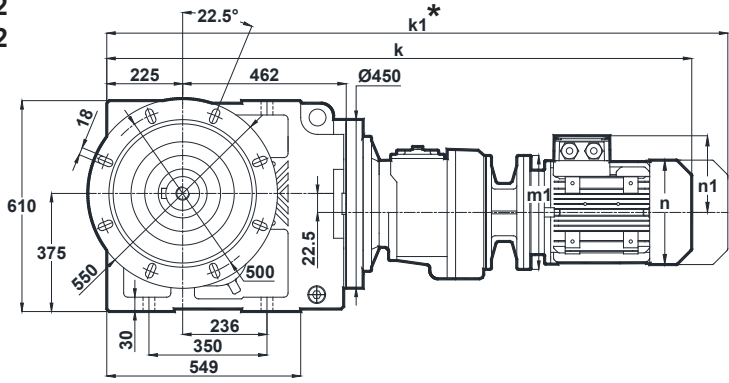

Klemens Pozisyonları  
Terminal Box Positions  
Klemmenkasten Positionen

	71/B5	80/B5 80/B14	90S/B5 90S/B14	90L/B5 90L/B14	100L/B5 100L/B14	112M/B5 112M/B14
k	1208	1231	1272	1272	1324	1345
k1	1299	1324	1376.5	1376.5	1443.5	1449.5
n / n1	137 / 112	155 / 121	176 / 132	176 / 132	193 / 147	215 / 158
m1 (B5)	160	200	200	200	250	250
m1 (B14)	-	120	140	140	160	160

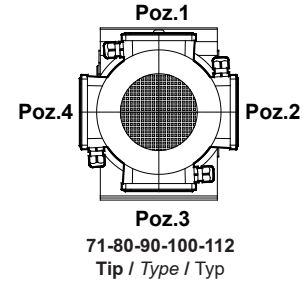

KV875.03  
KV876.03

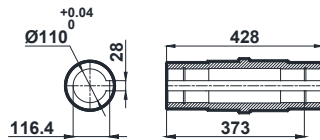
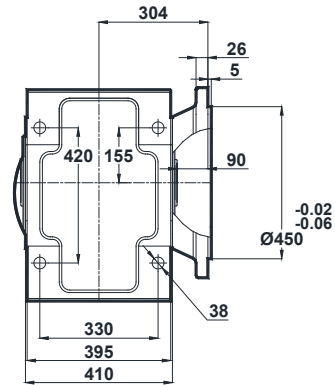
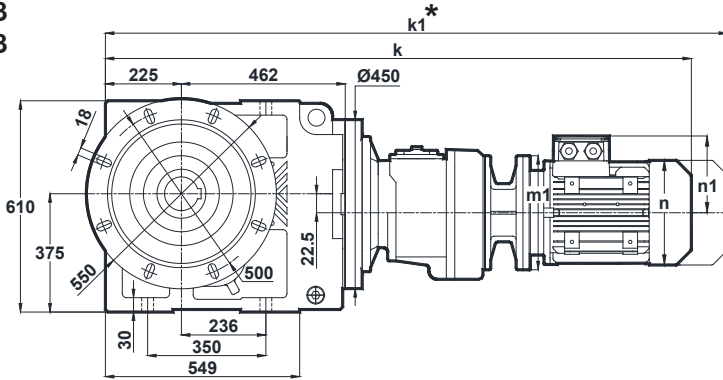

	71/B5	80/B5 80/B14	90S/B5 90S/B14	90L/B5 90L/B14	100L/B5 100L/B14	112M/B5 112M/B14
k	1208	1231	1272	1272	1324	1345
k1	1299	1324	1376.5	1376.5	1443.5	1449.5
n / n1	137 / 112	155 / 121	176 / 132	176 / 132	193 / 147	215 / 158
m1 (B5)	160	200	200	200	250	250
m1 (B14)	-	120	140	140	160	160

\* " k1 " Ölçüsü frenli redüktörlere aittir.  
Dimension " k1 " is for motors with brake.  
Maße " k1 " ist für Bremsenmotoren.

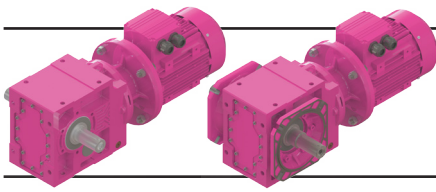

# Ölçü Sayfaları

## Dimension Pages

## Abmessungsseiten

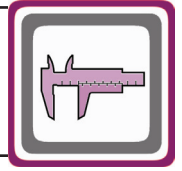

-Mil ucu çektirme deliği DIN 332 sayfa 2 / Tapped center hole to DIN 332, sheet 2 / Zentrierung mit Gewinde DIN 332, Blatt 2

KV875.04  
KV876.04

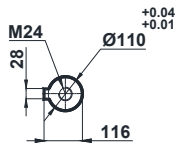
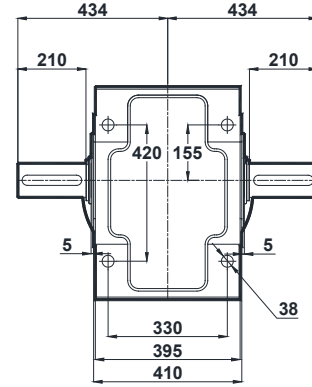
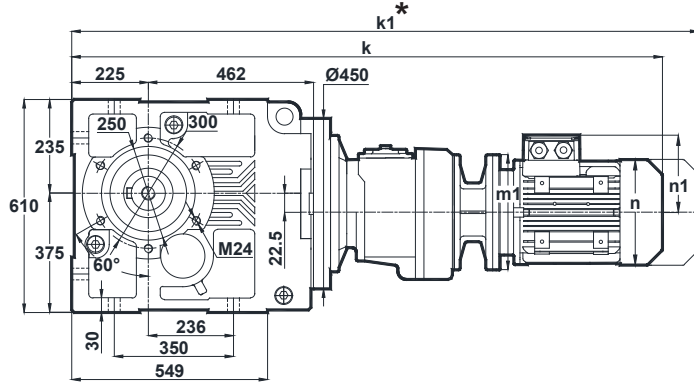

	71/B5	80/B5 80/B14	90S/B5 90S/B14	90L/B5 90L/B14	100L/B5 100L/B14	112M/B5 112M/B14
k	1208	1231	1272	1272	1324	1345
k1	1299	1324	1376.5	1376.5	1443.5	1449.5
n / n1	137 / 112	155 / 121	176 / 132	176 / 132	193 / 147	215 / 158
m1 (B5)	160	200	200	200	250	250
m1 (B14)	-	120	140	140	160	160

Klemens Pozisyonları  
Terminal Box Positions  
Klemmenkasten Positionen

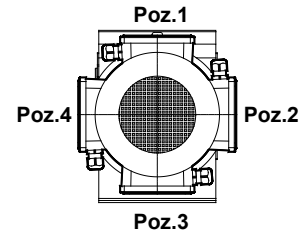

71-80-90-100-112  
Tip / Type / Typ

KV875.05  
KV876.05

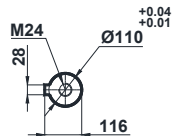
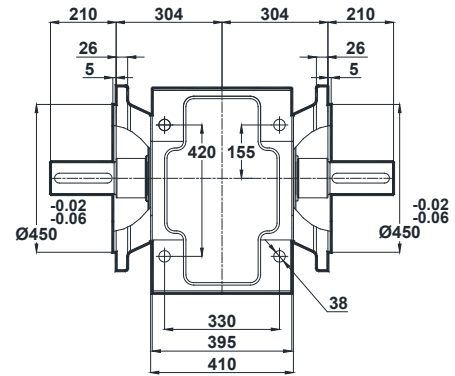
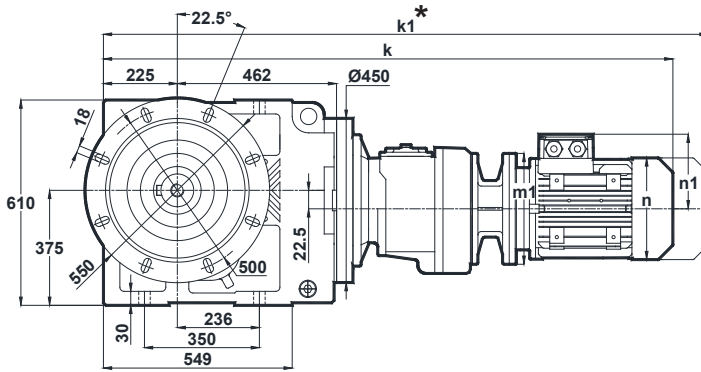

	71/B5	80/B5 80/B14	90S/B5 90S/B14	90L/B5 90L/B14	100L/B5 100L/B14	112M/B5 112M/B14
k	1208	1231	1272	1272	1324	1345
k1	1299	1324	1376.5	1376.5	1443.5	1449.5
n / n1	137 / 112	155 / 121	176 / 132	176 / 132	193 / 147	215 / 158
m1 (B5)	160	200	200	200	250	250
m1 (B14)	-	120	140	140	160	160

\* " k1 " Ölçüsü frenli redüktörlere aittir.  
Dimension " k1 " is for motors with brake.  
Maße " k1 " ist für Bremsmotoren.



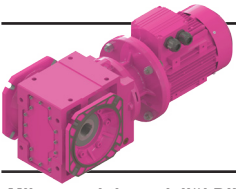

# Ölçü Sayfaları Dimension Pages Abmessungsseiten



-Mil ucu çektirme deliği DIN 332 sayfa 2 / Tapped center hole to DIN 332, sheet 2 / Zentrierung mit Gewinde DIN 332, Blatt 2

KV875.08  
KV876.08

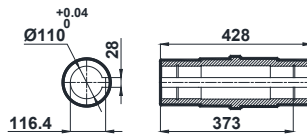
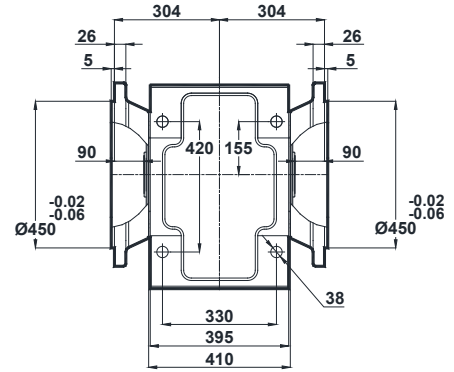
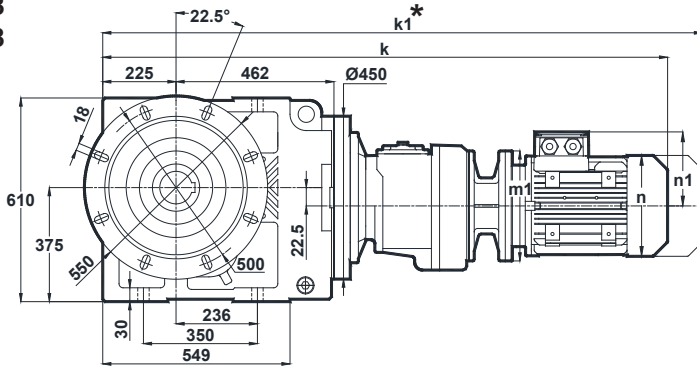

Klemens Pozisyonları  
Terminal Box Positions  
Klemmenkasten Positionen

	71/B5	80/B5 80/B14	90S/B5 90S/B14	90L/B5 90L/B14	100L/B5 100L/B14	112M/B5 112M/B14
k	1208	1231	1272	1272	1324	1345
k1	1299	1324	1376.5	1376.5	1443.5	1449.5
n / n1	137 / 112	155 / 121	176 / 132	176 / 132	193 / 147	215 / 158
m1 (B5)	160	200	200	200	250	250
m1 (B14)	-	120	140	140	160	160

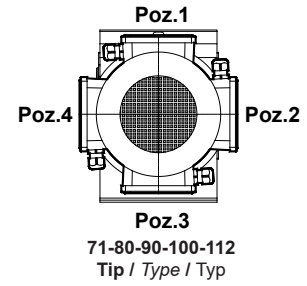

\* " k1 " Ölçüsü frenli redüktörlere aittir.  
Dimension " k1 " is for motors with brake.  
Maße " k1 " ist für Bremsenmotoren.



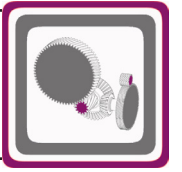
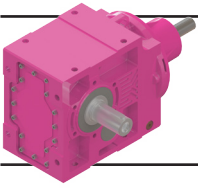

# Güç ve Devir Tabloları

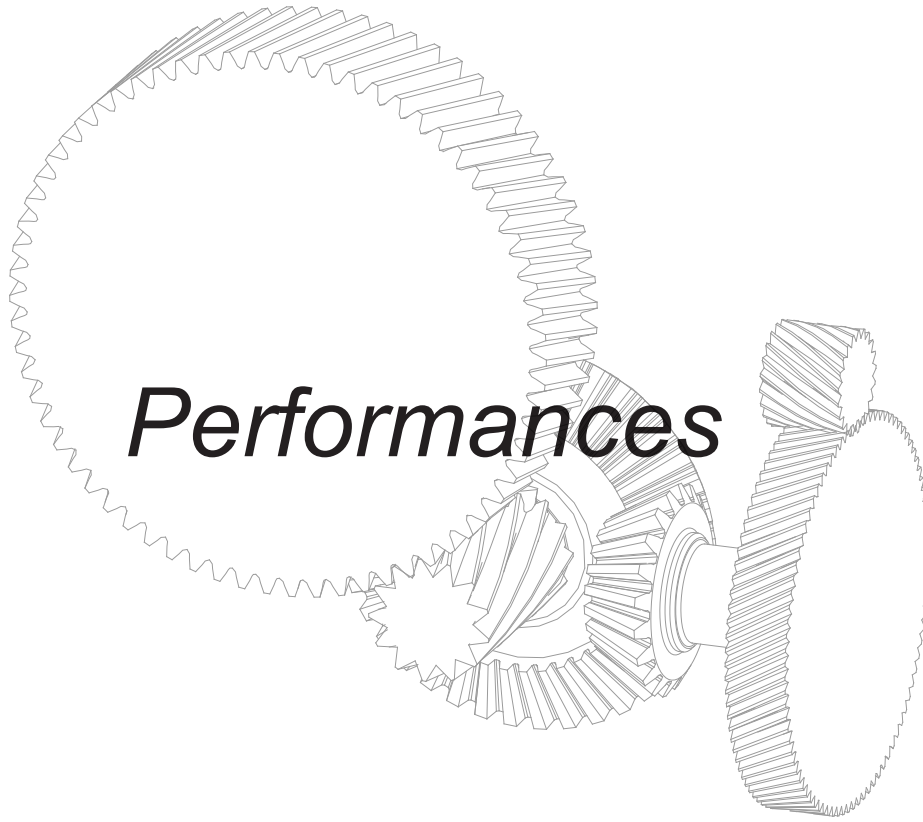

## Leistung und Drehzahlübersicht

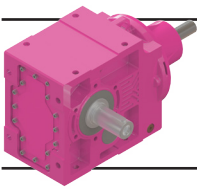

# K Serisi Motorsuz Güç Devir Sayfaları

## K Series Gear Units Performance Tables

### K Serien Getriebe Leistung und Drehzahlübersicht

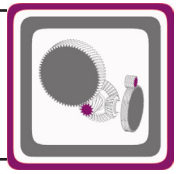

Anma Momenti Nominal Torques Nenn-drehmomente Ma [Nm] (n1=1450rpm)	Çevrim Oranı	Çıkış Devri	Tipi	Pe= Nominal Güç [kW] (Servis Faktörü fs=1,0 için)						Güv. Rad.Yük Çıkış	Güv.Rad.Yük Giriş	Ağırlık	Ölçü Sayfası
	Ratio	Output Speeds		Type	Pe= Nominal Power [kW] (For Service Factor fs=1,0)						Per.O.Loads (Output)		
	Übersetzung	Abtriebs-drehzahlen	Typ	Giriş devri[d/d] / Input speed[rpm] / Antriebsdrehzahl[upm]						Zul.Querkräfte (Abtrieb)	Zul.Querkräfte (Antrieb)	Gewicht	Maße Seite
	i	n2 [r.p.m] (n1=1450rpm)		n1=2900	n1=1450	n1=950	n1=725	n1=475	n1=360	Fqam [N] (n1=1450rpm)	Fqem [N] (n1=1450rpm)	[kg]	
<b>65</b>	7,46	194	<b>KT002</b>	2,3	<b>1,4</b>	1,1	0,86	0,56	0,43	2664	40	14	374
<b>65</b>	8,04	180		2,2	<b>1,3</b>	0,98	0,80	0,52	0,40	2748	91		
<b>70</b>	9,40	154		1,9	<b>1,2</b>	0,90	0,69	0,45	0,34	2879	48		
<b>75</b>	11,09	131		1,7	<b>1,1</b>	0,76	0,58	0,38	0,29	3031	-		
<b>75</b>	13,26	109		1,5	<b>0,91</b>	0,64	0,49	0,32	0,24	3265	96		
<b>75</b>	14,73	98		1,3	<b>0,82</b>	0,58	0,44	0,29	0,22	3408	195		
<b>75</b>	16,18	90		1,2	<b>0,75</b>	0,52	0,40	0,26	0,20	3540	211		
<b>80</b>	19,88	73		1,1	<b>0,65</b>	0,43	0,33	0,21	0,16	3794	161		
<b>80</b>	23,79	61	<b>KT003</b>	0,96	<b>0,55</b>	0,36	0,28	0,18	0,14	3153	764	15	374
<b>80</b>	25,64	57		0,89	<b>0,51</b>	0,34	0,26	0,17	0,13	3269	770		
<b>80</b>	29,95	48		0,82	<b>0,44</b>	0,29	0,22	0,15	0,11	3518	781		
<b>80</b>	35,34	41		0,70	<b>0,38</b>	0,25	0,19	0,12	0,09	3799	791		
<b>80</b>	45,41	32		0,58	<b>0,29</b>	0,19	0,15	0,10	0,07	4042	869		
<b>80</b>	48,93	30		0,54	<b>0,27</b>	0,18	0,14	0,09	0,07	4046	872		
<b>80</b>	57,16	25		0,47	<b>0,24</b>	0,15	0,12	0,08	0,06	4046	878		
<b>80</b>	67,44	22		0,40	<b>0,20</b>	0,13	0,10	0,07	0,05	4048	883		
<b>80</b>	80,66	18		0,34	<b>0,17</b>	0,11	0,09	0,06	0,04	4046	887		
<b>80</b>	89,62	16		0,31	<b>0,15</b>	0,10	0,08	0,05	0,04	4046	893		
<b>80</b>	98,44	15		0,28	<b>0,14</b>	0,09	0,07	0,05	0,04	4040	894		
<b>80</b>	120,91	12		0,23	<b>0,12</b>	0,08	0,06	0,04	0,03	4049	896		
<b>90</b>	6,28	231	<b>KT102</b>	3,5	<b>2,3</b>	1,7	1,8	1,2	0,89	2785	-	15	378
<b>90</b>	7,29	199		3,3	<b>2,0</b>	1,5	1,5	1,0	0,77	2971	-		
<b>95</b>	8,72	166		2,9	<b>1,7</b>	1,3	1,3	0,85	0,64	3160	-		
<b>100</b>	10,32	140		2,5	<b>1,5</b>	1,2	1,1	0,71	0,54	3347	-		
<b>100</b>	11,05	131		2,5	<b>1,4</b>	1,1	1,0	0,67	0,51	3446	-		
<b>105</b>	12,51	116		2,2	<b>1,3</b>	1,0	0,90	0,59	0,45	3585	-		
<b>110</b>	14,61	99		2,0	<b>1,2</b>	0,94	0,77	0,51	0,38	3780	-		
<b>110</b>	17,30	84		1,7	<b>1,0</b>	0,79	0,65	0,43	0,33	4062	-		
<b>110</b>	19,13	76		1,5	<b>0,93</b>	0,72	0,59	0,39	0,29	4236	-		
<b>115</b>	21,25	68		1,4	<b>0,87</b>	0,65	0,53	0,35	0,27	4377	-		
<b>120</b>	25,50	57		1,3	<b>0,76</b>	0,58	0,45	0,29	0,22	4672	-		
<b>115</b>	20,03	72		<b>KT103</b>	1,5	<b>0,93</b>	0,70	0,55	0,38	0,29	4176		
<b>120</b>	23,22	62	1,3		<b>0,84</b>	0,62	0,50	0,33	0,25	4397	710		
<b>125</b>	27,81	52	1,2		<b>0,74</b>	0,54	0,41	0,27	0,21	4696	722		
<b>130</b>	32,90	44	1,0		<b>0,65</b>	0,46	0,35	0,23	0,18	4992	725		
<b>135</b>	35,22	41	1,0		<b>0,63</b>	0,43	0,33	0,22	0,16	5084	721		
<b>135</b>	38,22	38	0,94		<b>0,58</b>	0,40	0,30	0,20	0,15	5266	812		
<b>140</b>	44,32	33	0,85		<b>0,52</b>	0,34	0,26	0,17	0,13	5553	816		
<b>140</b>	53,07	27	0,74		<b>0,44</b>	0,29	0,22	0,14	0,11	5825	830		
<b>140</b>	62,79	23	0,66		<b>0,37</b>	0,24	0,19	0,12	0,09	5827	838		
<b>140</b>	67,22	22	0,64		<b>0,35</b>	0,23	0,17	0,11	0,09	5823	841		
<b>140</b>	76,13	19	0,59		<b>0,31</b>	0,20	0,15	0,10	0,08	5827	844		
<b>140</b>	88,87	16	0,53		<b>0,26</b>	0,17	0,13	0,09	0,07	5831	849		
<b>140</b>	105,26	14	0,45		<b>0,23</b>	0,15	0,11	0,07	0,06	5826	854		
<b>140</b>	116,34	12	0,41		<b>0,20</b>	0,13	0,10	0,07	0,05	5826	862		
<b>140</b>	129,27	11	0,37		<b>0,18</b>	0,12	0,09	0,06	0,05	5826	864		
<b>205</b>	6,38	227	<b>KT202</b>		8,1	<b>5,1</b>	3,8	3,1	2,3	1,7	2306	-	19
<b>215</b>	7,65	190		7,2	<b>4,5</b>	3,3	2,7	1,9	1,5	2473	-		
<b>230</b>	9,25	157		6,3	<b>4,0</b>	2,9	2,4	1,6	1,2	2627	-		
<b>235</b>	10,57	137		5,7	<b>3,5</b>	2,7	2,1	1,4	1,1	2792	128		
<b>245</b>	12,17	119		5,2	<b>3,2</b>	2,4	1,8	1,2	0,92	2937	130		
<b>255</b>	14,32	101		4,5	<b>2,8</b>	2,0	1,6	1,0	0,78	3131	140		
<b>260</b>	15,26	95		4,4	<b>2,7</b>	1,9	1,5	0,96	0,73	3203	121		
<b>270</b>	17,47	83		3,9	<b>2,5</b>	1,7	1,3	0,84	0,64	3367	86		
<b>280</b>	20,23	72		3,5	<b>2,2</b>	1,5	1,1	0,73	0,55	3566	51		
<b>280</b>	23,79	61		3,2	<b>1,9</b>	1,2	0,95	0,62	0,47	3893	189		

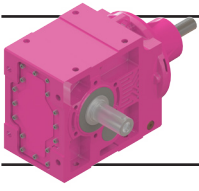

# K Serisi Motorsuz Güç Devir Sayfaları

## K Series Gear Units Performance Tables

### K Serien Getriebe Leistung und Drehzahlübersicht

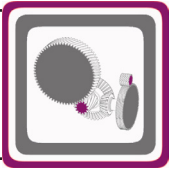

Anma Momenti <i>Nominal Torques</i> Nenn-drehmomente Ma [Nm] (n1=1450rpm)	Çevrim Oranı	Çıkış Devri	Tipi	Pe= Nominal Güç [kW] (Servis Faktörü fs=1,0 için)						Güv. Rad.Yük Çıkış	Güv.Rad.Yük Giriş	Ağırlık	Ölçü Sayfası			
	Ratio	Output Speeds		Type	Pe= Nominal Power [kW] (For Service Factor fs=1,0)											
	Übersetzung	Abtriebs-drehzahlen	Typ	Giriş devri[d/d] / Input speed[rpm] / Antriebsdrehzahl[upm]						Zul.Querkräfte (Abtrieb)	Zul.Querkräfte (Antrieb)	Gewicht	Maße Seite			
	i	n2 [r.p.m] (n1=1450rpm)	n1=2900	n1=1450	n1=950	n1=725	n1=475	n1=360	Fqam [N] (n1=1450rpm)					Fqem [N] (n1=1450rpm)	[kg]	
<b>265</b>	26,31	55	<b>KT203</b>	2,6	<b>1,6</b>	1,1	0,87	0,57	0,43	3916	1713	20	382			
<b>280</b>	31,55	46		2,3	<b>1,4</b>	0,95	0,72	0,48	0,36	4177	1721					
<b>280</b>	38,16	38		2,0	<b>1,2</b>	0,79	0,60	0,39	0,30	4644	1746					
<b>280</b>	43,67	33		1,8	<b>1,0</b>	0,69	0,52	0,34	0,26	4993	1841					
<b>280</b>	52,37	28		1,6	<b>0,87</b>	0,57	0,44	0,29	0,22	5483	1858					
<b>280</b>	63,33	23		1,4	<b>0,72</b>	0,48	0,36	0,24	0,18	6027	1873					
<b>280</b>	72,37	20		1,3	<b>0,64</b>	0,42	0,32	0,21	0,16	6428	1882					
<b>280</b>	83,32	17		1,1	<b>0,55</b>	0,36	0,28	0,18	0,14	6870	1890					
<b>280</b>	98,01	15		0,94	<b>0,47</b>	0,31	0,24	0,16	0,12	7403	1898					
<b>280</b>	104,49	14		0,88	<b>0,44</b>	0,29	0,22	0,15	0,11	7506	1901					
<b>280</b>	119,62	12		0,77	<b>0,39</b>	0,26	0,20	0,13	0,10	7497	1906					
<b>280</b>	138,53	10		0,67	<b>0,34</b>	0,22	0,17	0,11	0,08	7500	1911					
<b>220</b>	6,94	209		<b>KT273</b>	8,85	<b>5,1</b>	3,4	3,14	2,14	1,91	10742			-	25	386
<b>230</b>	8,28	175			7,81	<b>4,5</b>	2,9	2,73	1,92	1,70	11343			-		
<b>240</b>	9,92	146	6,84		<b>3,9</b>	2,6	2,36	1,65	1,45	12003	35					
<b>250</b>	12,00	121	5,92		<b>3,4</b>	2,2	2,09	1,46	1,27	12743	159					
<b>350</b>	13,34	109	7,26		<b>4,2</b>	2,8	2,54	1,75	1,35	12701	534					
<b>370</b>	15,92	91	6,29		<b>3,8</b>	2,5	2,23	1,50	1,13	12587	631					
<b>390</b>	19,08	76	5,59		<b>3,3</b>	2,2	1,90	1,25	0,95	12465	715					
<b>410</b>	23,08	63	4,90		<b>2,9</b>	1,9	1,57	1,03	0,78	12335	788					
<b>430</b>	25,55	57	4,55		<b>2,7</b>	1,8	1,42	0,93	0,71	12198	1277					
<b>450</b>	30,48	48	4,03		<b>2,4</b>	1,6	1,19	0,78	0,59	12000	1298					
<b>450</b>	36,55	40	3,54		<b>2,0</b>	1,3	0,99	0,65	0,49	12000	1339					
<b>450</b>	44,20	33	3,14		<b>1,6</b>	1,1	0,82	0,54	0,41	12000	1373					
<b>450</b>	50,51	29	2,81		<b>1,4</b>	0,9	0,72	0,47	0,36	12000	1394					
<b>450</b>	58,15	25	2,50		<b>1,2</b>	0,8	0,62	0,41	0,31	12000	1413					
<b>450</b>	68,40	21	2,13		<b>1,1</b>	0,7	0,53	0,35	0,26	12000	1431					
<b>450</b>	72,92	20	1,99		<b>1,0</b>	0,7	0,50	0,33	0,27	12000	1437					
<b>450</b>	83,48	17	1,74		<b>0,87</b>	0,6	0,44	0,29	0,24	12000	1450					
<b>450</b>	96,68	15	1,50	<b>0,75</b>	0,5	0,38	0,27	0,21	12000	1461						
<b>450</b>	113,65	13	1,28	<b>0,64</b>	0,4	0,32	0,23	0,18	12000	1472						
<b>450</b>	112,73	13	<b>KT275</b>	1,4	<b>0,68</b>	0,44	0,34	0,25	0,19	12000	613	28	390			
<b>450</b>	131,68	11		1,2	<b>0,58</b>	0,38	0,29	0,21	0,16	12000	627					
<b>450</b>	200,35	7,2		0,77	<b>0,38</b>	0,25	0,21	0,14	0,11	12000	732					
<b>450</b>	215,91	6,7		0,71	<b>0,36</b>	0,26	0,20	0,13	0,10	12000	736					
<b>450</b>	252,20	5,7		0,61	<b>0,31</b>	0,22	0,17	0,11	0,08	12000	743					
<b>450</b>	300,85	4,8		0,51	<b>0,26</b>	0,19	0,14	0,09	0,07	12000	763					
<b>450</b>	360,73	4,0		0,48	<b>0,24</b>	0,17	0,13	0,09	0,07	12000	781					
<b>450</b>	436,24	3,3		0,39	<b>0,20</b>	0,14	0,11	0,07	0,05	12000	796					
<b>450</b>	498,55	2,9		0,35	<b>0,17</b>	0,13	0,10	0,06	0,05	12000	805					
<b>450</b>	573,99	2,5		0,30	<b>0,15</b>	0,11	0,08	0,05	0,04	12000	814					
<b>450</b>	675,13	2,1		0,26	<b>0,13</b>	0,09	0,07	0,05	0,04	12000	822					
<b>450</b>	719,79	2,0		0,27	<b>0,12</b>	0,09	0,07	0,04	0,03	12000	825					
<b>450</b>	735,42	2,0		<b>KT276</b>	0,27	<b>0,12</b>	0,09	0,07	0,04	0,03	12000			826	30	390
<b>450</b>	881,79	1,6			0,22	<b>0,10</b>	0,07	0,06	0,04	0,03	12000			833		
<b>450</b>	1066,35	1,4	0,18		<b>0,08</b>	0,06	0,05	0,03	0,02	12000	840					
<b>450</b>	1218,69	1,2	0,16		<b>0,07</b>	0,05	0,04	0,03	0,02	12000	843					
<b>450</b>	1403,10	1,0	0,14		<b>0,06</b>	0,05	0,03	0,02	0,02	12000	847					
<b>450</b>	1650,31	0,88	0,12		<b>0,05</b>	0,04	0,03	0,02	0,01	12000	850					
<b>450</b>	1759,48	0,82	0,11		<b>0,05</b>	0,04	0,03	0,02	0,01	12000	851					
<b>580</b>	5,68	255	<b>KT373</b>	27	<b>17</b>	12	10	7,6	5,8	10852	-	60	394			
<b>595</b>	6,63	219		23	<b>15</b>	11	8,8	6,5	5,0	11453	-					
<b>610</b>	7,73	188		21	<b>13</b>	9,7	7,8	5,6	4,3	12082	-					
<b>630</b>	8,54	170		19	<b>12</b>	8,9	7,2	5,1	3,9	12440	-					
<b>655</b>	9,97	145		17	<b>11</b>	7,9	6,4	4,4	3,3	13063	-					
<b>805</b>	10,60	137		20	<b>12</b>	8,2	6,2	4,1	3,1	12341	-					
<b>820</b>	12,38	117		18	<b>11</b>	7,0	5,3	3,5	2,7	11800	-					
<b>820</b>	14,44	100		16	<b>9,2</b>	6,0	4,6	3,0	2,3	11800	-					

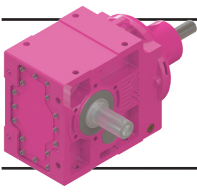

# K Serisi Motorsuz Güç Devir Sayfaları

## K Series Gear Units Performance Tables

### K Serien Getriebe Leistung und Drehzahlübersicht

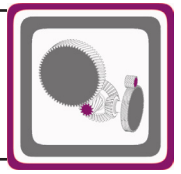

Anma Momenti <i>Nominal Torques</i> Nenn-drehmomente Ma [Nm] (n1=1450rpm)	Çevrim Oranı	Çıkış Devri	Tipi	Pe= Nominal Güç [kW] (Servis Faktörü fs=1,0 için)						Güv. Rad.Yük Çıkış	Güv.Rad.Yük Giriş	Ağırlık	Ölçü Sayfası
	Ratio	Output Speeds		Type	Pe= Nominal Power [kW] (For Service Factor fs=1,0)						Per.O.Loads (Output)		
	Übersetzung	Abtriebs-drehzahlen	Typ	Giriş devri[d/d] / Input speed[rpm] / Antriebsdrehzahl[upm]						Zul.Querkräfte (Abtrieb)	Zul.Querkräfte (Antrieb)	Gewicht	Maße Seite
	i	n2 [r.p.m] (n1=1450rpm)		n1=2900	n1=1450	n1=950	n1=725	n1=475	n1=360	Fqam [N] (n1=1450rpm)	Fqem [N] (n1=1450rpm)	[kg]	
<b>820</b>	15,96	91	<b>KT373</b>	15	<b>8,3</b>	5,4	4,2	2,7	2,1	11800	-	60	394
<b>820</b>	18,62	78		13	<b>7,1</b>	4,7	3,6	2,3	1,8	11800	-		
<b>820</b>	21,90	66		12	<b>6,0</b>	4,0	3,0	2,0	1,5	11800	-		
<b>820</b>	24,72	59		11	<b>5,4</b>	3,5	2,7	1,8	1,3	11800	1429		
<b>820</b>	28,85	50		9,2	<b>4,6</b>	3,0	2,3	1,5	1,1	11800	1490		
<b>820</b>	33,65	43		7,9	<b>3,9</b>	2,6	2,0	1,3	0,98	11800	1549		
<b>820</b>	37,19	39		7,1	<b>3,6</b>	2,3	1,8	1,2	0,88	11800	1579		
<b>820</b>	43,40	33		6,1	<b>3,1</b>	2,0	1,5	1,0	0,76	11800	1619		
<b>820</b>	51,05	28		5,2	<b>2,6</b>	1,7	1,3	0,85	0,64	11800	1654		
<b>820</b>	60,69	24		4,4	<b>2,2</b>	1,4	1,1	0,71	0,54	11800	1686		
<b>820</b>	68,65	21		3,9	<b>1,9</b>	1,3	0,96	0,63	0,48	11800	1705		
<b>820</b>	78,29	19		3,4	<b>1,7</b>	1,1	0,85	0,55	0,42	11800	1723		
<b>820</b>	97,26	15		2,7	<b>1,4</b>	0,89	0,68	0,45	0,34	11800	1749		
<b>820</b>	110,61	13		2,4	<b>1,2</b>	0,78	0,60	0,39	0,30	11800	1761		
<b>820</b>	127,30	11		2,1	<b>1,0</b>	0,68	0,52	0,34	0,26	11800	1773		
<b>820</b>	148,75	9,7	1,8	<b>0,89</b>	0,58	0,45	0,29	0,25	11800	1783			
<b>820</b>	127,14	11	<b>KT374</b>	2,1	<b>1,1</b>	0,70	0,54	0,35	0,27	11800	1411	61	398
<b>820</b>	140,49	10		1,9	<b>0,97</b>	0,64	0,49	0,32	0,27	11800	1450		
<b>820</b>	163,96	8,8		1,7	<b>0,83</b>	0,55	0,42	0,27	0,23	11800	1503		
<b>820</b>	192,86	7,5		1,4	<b>0,71</b>	0,47	0,36	0,26	0,20	11800	1551		
<b>820</b>	229,29	6,3		1,2	<b>0,60</b>	0,39	0,30	0,22	0,16	11800	1594		
<b>820</b>	259,36	5,6		1,1	<b>0,53</b>	0,35	0,26	0,19	0,15	11800	1620		
<b>820</b>	295,76	4,9		0,93	<b>0,46</b>	0,30	0,26	0,17	0,13	11800	1645		
<b>820</b>	367,43	3,9		0,75	<b>0,37</b>	0,27	0,21	0,14	0,10	11800	1679		
<b>820</b>	374,18	3,9		<b>KT375</b>	0,75	<b>0,38</b>	0,27	0,21	0,14	0,10	11800		
<b>820</b>	442,71	3,3	0,64		<b>0,32</b>	0,23	0,18	0,12	0,09	11800	1052		
<b>820</b>	473,96	3,1	0,59		<b>0,30</b>	0,22	0,17	0,11	0,08	11800	1055		
<b>820</b>	536,75	2,7	0,53		<b>0,26</b>	0,19	0,15	0,10	0,07	11800	1057		
<b>820</b>	593,11	2,4	0,53		<b>0,26</b>	0,19	0,15	0,10	0,07	11800	1067		
<b>820</b>	692,22	2,1	0,45		<b>0,23</b>	0,17	0,13	0,08	0,06	11800	1079		
<b>820</b>	814,20	1,8	0,39		<b>0,19</b>	0,14	0,11	0,07	0,05	11800	1091		
<b>820</b>	968,01	1,5	0,32		<b>0,16</b>	0,12	0,09	0,06	0,04	11800	1102		
<b>820</b>	1094,97	1,3	0,29		<b>0,14</b>	0,10	0,08	0,05	0,04	11800	1108		
<b>820</b>	1184,90	1,2	<b>KT376</b>	0,27	<b>0,14</b>	0,10	0,08	0,05	0,04	11800	1122	64	402
<b>820</b>	1401,91	1,0		0,25	<b>0,11</b>	0,08	0,06	0,04	0,03	11800	1124		
<b>820</b>	1500,87	0,97		0,24	<b>0,11</b>	0,08	0,06	0,04	0,03	11800	1125		
<b>820</b>	1699,70	0,85		0,21	<b>0,09</b>	0,07	0,05	0,03	0,03	11800	1125		
<b>820</b>	1878,17	0,77		0,19	<b>0,09</b>	0,06	0,05	0,03	0,02	11800	1128		
<b>820</b>	2192,03	0,66		0,16	<b>0,07</b>	0,05	0,04	0,03	0,02	11800	1132		
<b>820</b>	2578,32	0,56		0,14	<b>0,06</b>	0,05	0,03	0,02	0,02	11800	1136		
<b>820</b>	3065,37	0,47		0,12	<b>0,05</b>	0,04	0,03	0,02	0,01	11800	1139		
<b>820</b>	3467,39	0,42		0,10	<b>0,05</b>	0,03	0,03	0,02	0,01	11800	1141		
<b>830</b>	6,21	233	<b>KT473</b>	35	<b>22</b>	16	12	9,9	8,1	12268	-	96	406
<b>865</b>	7,48	194		30	<b>19</b>	14	11	8,6	7,0	13041	-		
<b>905</b>	9,06	160		26	<b>16</b>	12	9,2	7,4	6,1	13870	-		
<b>935</b>	10,34	140		24	<b>15</b>	11	8,4	6,7	5,5	14467	-		
<b>970</b>	11,87	122		21	<b>13</b>	9,9	7,5	6,1	5,0	15099	-		
<b>1005</b>	13,71	106		19	<b>12</b>	8,9	6,8	5,5	4,5	15811	-		
<b>1370</b>	15,33	95		23	<b>14</b>	11	8,2	5,4	4,1	16173	-		
<b>1425</b>	17,49	83		21	<b>13</b>	9,4	7,2	4,7	3,6	16829	-		
<b>1485</b>	20,07	72		19	<b>12</b>	8,2	6,2	4,1	3,1	17538	-		
<b>1550</b>	23,19	63		18	<b>11</b>	7,1	5,4	3,5	2,7	17000	-		
<b>1550</b>	23,76	61		17	<b>11</b>	6,9	5,3	3,5	2,6	17000	-		
<b>1550</b>	25,15	58		17	<b>10</b>	6,5	5,0	3,3	2,5	17000	-		
<b>1550</b>	30,11	48		15	<b>8,3</b>	5,4	4,2	2,7	2,1	17000	-		
<b>1550</b>	39,11	37		12	<b>6,4</b>	4,2	3,2	2,1	1,6	17000	1424		
<b>1550</b>	44,64	32		11	<b>5,6</b>	3,7	2,8	1,8	1,4	17000	1563		
<b>1550</b>	51,22	28		9,6	<b>4,9</b>	3,2	2,4	1,6	1,2	17000	1612		
<b>1550</b>	59,19	24		8,5	<b>4,2</b>	2,8	2,1	1,4	1,1	17000	1657		

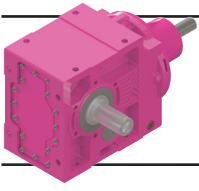

# K Serisi Motorsuz Güç Devir Sayfaları

## K Series Gear Units Performance Tables

### K Serien Getriebe Leistung und Drehzahlübersicht

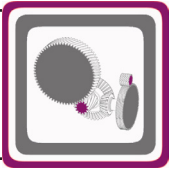

Anma Momenti <i>Nominal Torques</i> Nenn-drehmomente Ma [Nm] (n1=1450rpm)	Çevrim Oranı <i>Ratio</i> Übersetzung i	Çıkış Devri <i>Output Speeds</i> Abtriebs-drehzahlen n2 [r.p.m] (n1=1450rpm)	Tipi <i>Type</i> Typ	Pe= Nominal Güç [kW] (Servis Faktörü fs=1,0 için) <i>Pe= Nominal Power [kW] (For Service Factor fs=1,0)</i> Pe= NennLeistung [kW] (Bei Betriebsfaktor fs=1,0)						Güv. Rad.Yük Çıkış <i>Per.O.Loads (Output)</i> Zul.Querkräfte (Abtrieb) Fqam [N] (n1=1450rpm)	Güv.Rad.Yük Giriş <i>Per.O.Loads (Input)</i> Zul.Querkräfte (Antrieb) Fqem [N] (n1=1450rpm)	Ağırlık <i>Weight</i> Gewicht [kg]	Ölçü Sayfası <i>Dim. Page</i> Maße Seite
				Giriş devri[d/d] / Input speed[rpm] / Antriebsdrehzahl[upm]									
				n1=2900	n1=1450	n1=950	n1=725	n1=475	n1=360				
				1550	60,63	24	KT473	8,3	4,1	2,7	2,1	1,4	1,0
1550	64,17	23		7,8	3,9	2,6	2,0	1,3	0,97	17000	1683		
1550	76,83	19		6,5	3,3	2,1	1,6	1,1	0,81	17000	1726		
1550	87,49	17		5,7	2,9	1,9	1,4	0,94	0,71	17000	1753		
1550	97,79	15		5,1	2,6	1,7	1,3	0,84	0,64	17000	1777		
1550	110,65	13		4,5	2,3	1,5	1,1	0,74	0,56	17000	1796		
1550	135,98	11		3,7	1,8	1,2	0,92	0,60	0,46	17000	1823		
1550	153,47	9,4		3,3	1,6	1,1	0,82	0,53	0,41	17000	1835		
1550	160,79	9,0	KT474	3,2	1,6	1,0	0,80	0,52	0,40	17000	1870	98	410
1550	181,88	8,0		2,8	1,4	0,93	0,71	0,46	0,35	17000	1883		
1550	207,41	7,0		2,5	1,2	0,82	0,62	0,41	0,31	17000	1896		
1550	257,67	5,6		2,0	1,0	0,66	0,50	0,33	0,28	17000	1914		
1550	293,03	4,9		1,8	0,88	0,58	0,44	0,29	0,24	17000	1922		
1550	310,16	4,7		1,7	0,84	0,55	0,42	0,27	0,23	17000	1940		
1550	371,35	3,9		1,4	0,70	0,46	0,35	0,25	0,19	17000	1988		
1550	422,88	3,4		1,2	0,61	0,40	0,31	0,22	0,17	17000	2018		
1550	472,63	3,1		1,1	0,55	0,36	0,27	0,20	0,15	17000	2040		
1550	509,34	2,8	KT475	1,0	0,52	0,34	0,26	0,19	0,14	17000	1721	101	414
1550	610,72	2,4		0,87	0,43	0,28	0,24	0,16	0,12	17000	1729		
1550	655,16	2,2		0,81	0,40	0,27	0,22	0,15	0,11	17000	1731		
1550	738,55	2,0		0,72	0,36	0,26	0,20	0,13	0,10	17000	1735		
1550	844,06	1,7		0,63	0,32	0,23	0,18	0,11	0,09	17000	1740		
1550	901,03	1,6		0,59	0,30	0,22	0,16	0,11	0,08	17000	1741		
1550	971,77	1,5		0,55	0,27	0,20	0,15	0,10	0,08	17000	1743		
1550	1142,99	1,3		0,52	0,26	0,19	0,14	0,09	0,07	17000	1747		
1550	1218,61	1,2		0,49	0,24	0,18	0,14	0,09	0,07	17000	1748		
1550	1395,04	1,0		0,43	0,21	0,16	0,12	0,08	0,06	17000	1751		
1550	1476,60	0,98		0,40	0,20	0,15	0,11	0,07	0,06	17000	1755		
1550	1767,90	0,82		0,34	0,17	0,12	0,09	0,06	0,05	17000	1766		
1550	2183,54	0,66	KT476	0,28	0,14	0,10	0,08	0,05	0,04	17000	1792	104	414
1550	2495,47	0,58		0,27	0,12	0,09	0,07	0,04	0,03	17000	1794		
1550	2663,91	0,54		0,25	0,11	0,08	0,06	0,04	0,03	17000	1794		
1550	2873,07	0,50		0,23	0,11	0,08	0,06	0,04	0,03	17000	1795		
1550	3379,28	0,43		0,20	0,09	0,07	0,05	0,03	0,02	17000	1796		
1550	3602,83	0,40		0,19	0,08	0,06	0,05	0,03	0,02	17000	1797		
1550	4124,46	0,35		0,16	0,07	0,05	0,04	0,03	0,02	17000	1797		
1550	4365,60	0,33		0,15	0,07	0,05	0,04	0,03	0,02	17000	1799		
1550	5226,85	0,28		0,13	0,06	0,04	0,03	0,02	0,02	17000	1803		
1220	6,91	210	KT573	-	29	21	17	13	10,7	25040	-	138	418
1300	8,07	180		-	26	22	16	12	9,5	26129	-		
1380	9,48	153		38	24	18	14	11	8,9	27341	-		
1470	11,22	129		35	21	16	13	10	8,0	28667	-		
1700	11,58	125		-	24	18	14	11	9,0	28654	-		
1820	13,53	107		-	22	16	13	10	8,0	29850	-		
1930	15,88	91		32	20	15	12	9,0	6,8	31234	-		
2050	18,80	77		29	18	13	11	7,6	5,8	32541	-		
2100	20,24	72		28	17	13	10	7,1	5,4	31991	-		
2200	22,77	64		26	16	12	9,5	6,3	4,8	30822	-		
2300	25,78	56		24	14	11	8,5	5,5	4,2	29547	-		
2300	30,25	48		-	12	9,2	7,2	4,7	3,6	29547	2775		
2430	35,34	41		-	11	8,1	6,2	4,0	3,1	27711	2799		
2500	38,16	38		17	11	7,5	5,7	3,7	2,8	26625	2845		
2620	44,73	32		15	9,5	6,4	4,9	3,2	2,4	24571	2869		
2700	52,88	27		14	8,2	5,4	4,1	2,7	2,0	22500	2909		
2700	59,49	24		13	7,3	4,8	3,7	2,4	1,8	22500	2956		
2700	67,37	22		12	6,5	4,2	3,2	2,1	1,6	22500	3000		
2700	82,14	18		10	5,3	3,5	2,7	1,7	1,3	22500	3058		
2700	97,19	15		9,0	4,5	2,9	2,2	1,5	1,1	22500	3099		
2700	109,86	13		7,9	4,0	2,6	2,0	1,3	0,99	22500	3125		

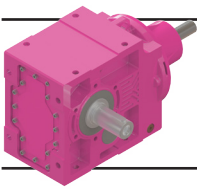

# K Serisi Motorsuz Güç Devir Sayfaları

## K Series Gear Units Performance Tables

### K Serien Getriebe Leistung und Drehzahlübersicht

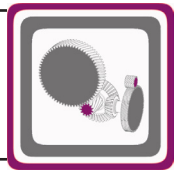

Anma Momenti  Nominal Torques  Nenn-drehmomente  Ma [Nm] (n1=1450rpm)	Çevrim Oranı	Çıkış Devri	Tipi  Type  Typ	Pe= Nominal Güç [kW] (Servis Faktörü fs=1,0 için)						Güv. Rad.Yük Çıkış	Güv.Rad.Yük Giriş	Ağırlık  Weight  Gewicht  [kg]	Ölçü Sayfası  Dim. Page  Maße Seite
	Ratio	Output Speeds		Pe= Nominal Power [kW] (For Service Factor fs=1,0)						Per.O.Loads (Output)	Per.O.Loads (Input)		
	Übersetzung	Abtriebs-drehzahlen		Pe= NennLeistung [kW] (Bei Betriebsfaktor fs=1,0)						Zul.Querkräfte (Abtrieb)	Zul.Querkräfte (Antrieb)		
	i	n2 [r.p.m] (n1=1450rpm)		Giriş devri[d/d] / Input speed[rpm] / Antriebsdrehzahl[upm]						Fqam [N] (n1=1450rpm)	Fqem [N] (n1=1450rpm)		
				n1=2900	n1=1450	n1=950	n1=725	n1=475	n1=360				
<b>2700</b>	125,51	12	<b>KT573</b>	6,9	<b>3,5</b>	2,3	1,7	1,1	0,86	22500	3149	138	418
<b>2700</b>	117,96	12	<b>KT574</b>	7,6	<b>3,8</b>	2,5	1,9	1,2	0,94	22500	1466	140	422
<b>2700</b>	140,24	10		6,4	<b>3,2</b>	2,1	1,6	1,0	0,79	22500	1510		
<b>2700</b>	158,64	9,1		5,7	<b>2,8</b>	1,9	1,4	0,93	0,70	22500	1536		
<b>2700</b>	180,90	8,0		5,0	<b>2,5</b>	1,6	1,2	0,81	0,62	22500	1561		
<b>2700</b>	211,51	6,9		4,3	<b>2,1</b>	1,4	1,1	0,70	0,53	22500	1587		
<b>2700</b>	237,97	6,1		3,8	<b>1,9</b>	1,2	0,95	0,62	0,47	22500	1659		
<b>2700</b>	246,42	5,9		3,6	<b>1,8</b>	1,2	0,91	0,60	0,45	22500	1785		
<b>2700</b>	281,00	5,2		3,2	<b>1,6</b>	1,0	0,80	0,52	0,40	22500	1801		
<b>2700</b>	328,56	4,4		2,7	<b>1,4</b>	0,90	0,69	0,45	0,34	22500	1817		
<b>2700</b>	397,01	3,7		2,3	<b>1,1</b>	0,75	0,57	0,37	0,28	22500	1834		
<b>2700</b>	469,74	3,1		1,9	<b>0,96</b>	0,63	0,48	0,32	0,27	22500	1896		
<b>2700</b>	507,09	2,9	<b>KT575</b>	1,8	<b>0,91</b>	0,60	0,46	0,30	0,25	22500	1483	140	426
<b>2700</b>	570,53	2,5		1,6	<b>0,81</b>	0,53	0,41	0,27	0,22	22500	1520		
<b>2700</b>	787,70	1,8		1,2	<b>0,59</b>	0,39	0,29	0,21	0,16	22500	1603		
<b>2700</b>	932,00	1,6		1,0	<b>0,50</b>	0,33	0,28	0,18	0,14	22500	1637		
<b>2700</b>	1216,74	1,2		0,77	<b>0,38</b>	0,25	0,21	0,14	0,11	22500	1680		
<b>2700</b>	1368,95	1,1		0,68	<b>0,34</b>	0,25	0,19	0,12	0,09	22500	1696		
<b>2700</b>	1890,04	0,77		0,55	<b>0,27</b>	0,20	0,15	0,10	0,08	22500	1731		
<b>2700</b>	2236,28	0,65		0,46	<b>0,23</b>	0,17	0,13	0,08	0,06	22500	1745		
<b>2700</b>	2328,84	0,62	<b>KT576</b>	0,45	<b>0,23</b>	0,17	0,13	0,08	0,06	22500	1748	145	426
<b>2700</b>	2755,47	0,53		0,38	<b>0,19</b>	0,14	0,11	0,07	0,05	22500	1759		
<b>2700</b>	3597,31	0,40		0,29	<b>0,15</b>	0,11	0,08	0,05	0,04	22500	1774		
<b>2700</b>	4047,32	0,36		0,26	<b>0,13</b>	0,10	0,07	0,05	0,04	22500	1779		
<b>2700</b>	5587,93	0,26		0,21	<b>0,09</b>	0,07	0,05	0,03	0,03	22500	1791		
<b>2700</b>	6611,61	0,22		0,18	<b>0,08</b>	0,06	0,04	0,03	0,02	22500	1795		
<b>2500</b>	8,31	175	<b>KT673</b>	-	<b>49</b>	37	30	23	18	38163	-	235	430
<b>2600</b>	9,45	153		-	<b>44</b>	33	27	20	16	39661	-		
<b>2700</b>	10,81	134		-	<b>40</b>	30	24	19	14	41324	-		
<b>2800</b>	12,46	116		58	<b>36</b>	27	22	16	12	43197	-		
<b>2900</b>	14,49	100		52	<b>32</b>	24	20	14	11	45335	-		
<b>4300</b>	16,54	88		-	<b>42</b>	28	21	14	10	29600	-		
<b>4300</b>	18,74	77		-	<b>37</b>	24	19	12	9,2	29600	-		
<b>4300</b>	21,32	68		-	<b>33</b>	21	16	11	8,1	29600	-		
<b>4300</b>	24,38	59		-	<b>28</b>	19	14	9,3	7,1	29600	-		
<b>4300</b>	28,10	52		49	<b>25</b>	16	12	8,1	6,1	29600	-		
<b>4300</b>	32,68	44		43	<b>21</b>	14	11	7,0	5,3	29600	-		
<b>4300</b>	39,26	37		-	<b>18</b>	12	8,8	5,8	4,4	29600	3132		
<b>4300</b>	44,65	32		-	<b>16</b>	10	7,8	5,1	3,9	29600	3223		
<b>4300</b>	51,08	28		-	<b>14</b>	8,9	6,8	4,5	3,4	29600	3306		
<b>4300</b>	58,86	25		24	<b>12</b>	7,7	5,9	3,9	2,9	29600	3381		
<b>4300</b>	68,47	21		20	<b>10</b>	6,6	5,1	3,3	2,5	29600	3451		
<b>4300</b>	80,38	18		17	<b>8,6</b>	5,7	4,3	2,8	2,1	29600	3541		
<b>4300</b>	90,21	16		15	<b>7,7</b>	5,0	3,8	2,5	1,9	29600	3579		
<b>4300</b>	100,90	14		14	<b>6,9</b>	4,5	3,4	2,3	1,7	29600	3600		
<b>4300</b>	128,24	11		11	<b>5,4</b>	3,5	2,7	1,8	1,3	29600	3675		
<b>4300</b>	123,38	12	<b>KT674</b>	11	<b>5,7</b>	3,8	2,9	1,9	1,4	29600	687	238	434
<b>4300</b>	140,49	10		10	<b>5,1</b>	3,3	2,5	1,7	1,3	29600	808		
<b>4300</b>	157,02	9,2		9,1	<b>4,5</b>	3,0	2,3	1,5	1,1	29600	920		
<b>4300</b>	178,62	8,1		8,0	<b>4,0</b>	2,6	2,0	1,3	0,99	29600	1342		
<b>4300</b>	204,32	7,1		7,0	<b>3,5</b>	2,3	1,7	1,1	0,87	29600	1616		
<b>4300</b>	235,44	6,2		6,1	<b>3,0</b>	2,0	1,5	0,99	0,75	29600	1702		
<b>4300</b>	273,88	5,3		5,2	<b>2,6</b>	1,7	1,3	0,85	0,65	29600	1781		
<b>4300</b>	321,51	4,5		4,4	<b>2,2</b>	1,5	1,1	0,73	0,55	29600	1853		
<b>4300</b>	363,81	4,0		3,9	<b>2,0</b>	1,3	0,98	0,64	0,49	29600	1865		



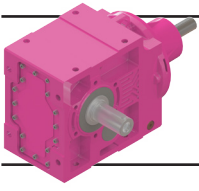

# K Serisi Motorsuz Güç Devir Sayfaları

## K Series Gear Units Performance Tables

### K Serien Getriebe Leistung und Drehzahlübersicht

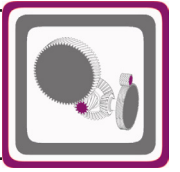

Anma Momenti <i>Nominal Torques</i> Nenn-drehmomente Ma [Nm] (n1=1450rpm)	Çevrim Oranı	Çıkış Devri	Tipi	Pe= Nominal Güç [kW] (Servis Faktörü fs=1,0 için)						Güv. Rad.Yük Çıkış	Güv.Rad.Yük Giriş	Ağırlık	Ölçü Sayfası
	Ratio	Output Speeds		Type	Pe= Nominal Power [kW] (For Service Factor fs=1,0)								
	Übersetzung	Abtriebs-drehzahlen	Typ	Giriş devri[d/d] / Input speed[rpm] / Antriebsdrehzahl[upm]						Zul.Querkräfte (Abtrieb)	Zul.Querkräfte (Antrieb)	Gewicht	Maße Seite
	i	n2 [r.p.m] (n1=1450rpm)		n1=2900	n1=1450	n1=950	n1=725	n1=475	n1=360	Fqam [N] (n1=1450rpm)	Fqem [N] (n1=1450rpm)	[kg]	
<b>4300</b>	423,90	3,4	<b>KT675</b>	3,4	<b>1,7</b>	1,1	0,86	0,56	0,43	29600	1852	243	438
<b>4300</b>	489,82	3,0		3,0	<b>1,5</b>	0,98	0,75	0,49	0,37	29600	1863		
<b>4300</b>	531,08	2,7		2,8	<b>1,4</b>	0,90	0,69	0,45	0,34	29600	1869		
<b>4300</b>	635,86	2,3		2,3	<b>1,2</b>	0,76	0,58	0,38	0,29	29600	1880		
<b>4300</b>	724,08	2,0		2,0	<b>1,0</b>	0,66	0,51	0,33	0,25	29600	1886		
<b>4300</b>	809,27	1,8		1,8	<b>0,91</b>	0,59	0,45	0,30	0,25	29600	1892		
<b>4300</b>	915,75	1,6		1,6	<b>0,80</b>	0,53	0,40	0,26	0,22	29600	1897		
<b>4300</b>	1041,68	1,4		1,4	<b>0,71</b>	0,46	0,35	0,26	0,20	29600	1916		
<b>4300</b>	1191,60	1,2		1,2	<b>0,62</b>	0,41	0,31	0,23	0,17	29600	1933		
<b>4300</b>	1373,07	1,1		1,1	<b>0,54</b>	0,35	0,27	0,20	0,15	29600	1949		
<b>4300</b>	1597,25	0,91		0,92	<b>0,46</b>	0,30	0,26	0,17	0,13	29600	1963		
<b>4300</b>	1875,03	0,77		0,79	<b>0,39</b>	0,26	0,22	0,14	0,11	29600	1977		
<b>4300</b>	1884,33	0,77	<b>KT676</b>	0,80	<b>0,40</b>	0,26	0,22	0,15	0,11	29600	2009	250	438
<b>4300</b>	2082,19	0,70		0,72	<b>0,36</b>	0,26	0,20	0,13	0,10	29600	2011		
<b>4300</b>	2430,14	0,60		0,62	<b>0,31</b>	0,23	0,17	0,11	0,09	29600	2014		
<b>4300</b>	2858,39	0,51		0,53	<b>0,26</b>	0,19	0,15	0,10	0,07	29600	2016		
<b>4300</b>	3398,35	0,43		0,50	<b>0,25</b>	0,18	0,14	0,09	0,07	29600	2018		
<b>4300</b>	3844,04	0,38		0,44	<b>0,22</b>	0,16	0,12	0,08	0,06	29600	2020		
<b>4300</b>	4383,55	0,33		0,39	<b>0,19</b>	0,14	0,11	0,07	0,05	29600	2021		
<b>4300</b>	5445,72	0,27		0,31	<b>0,16</b>	0,11	0,09	0,06	0,04	29600	2023		
<b>4300</b>	6193,17	0,23		0,27	<b>0,14</b>	0,10	0,08	0,05	0,04	29600	2024		
<b>4300</b>	7044,81	0,21		0,27	<b>0,12</b>	0,09	0,07	0,04	0,03	29600	2027		
<b>4300</b>	8058,67	0,18		0,23	<b>0,11</b>	0,08	0,06	0,04	0,03	29600	2030		
<b>4300</b>	9285,97	0,16		0,20	<b>0,09</b>	0,07	0,05	0,03	0,03	29600	2033		
<b>4300</b>	10802,05	0,13		0,17	<b>0,08</b>	0,06	0,04	0,03	0,02	29600	2036		
<b>4300</b>	12680,66	0,11		0,15	<b>0,07</b>	0,05	0,04	0,02	0,02	29600	2038		
<b>3900</b>	7,41	196	<b>KT773</b>	-	<b>80</b>	64	51	39	31	33549	-	360	442
<b>4050</b>	8,52	170		-	<b>72</b>	57	46	35	27	35041	-		
<b>4200</b>	9,83	147		-	<b>65</b>	52	41	31	24	36696	-		
<b>4250</b>	10,20	142		-	<b>63</b>	50	40	30	23	37083	-		
<b>4400</b>	11,44	127		-	<b>58</b>	46	37	27	20	38376	-		
<b>4500</b>	12,89	112		-	<b>53</b>	42	34	24	18	40022	-		
<b>7250</b>	15,25	95		-	<b>72</b>	56	42	28	21	36482	-		
<b>7550</b>	17,52	83		-	<b>65</b>	48	37	24	18	38064	-		
<b>7900</b>	20,23	72		-	<b>59</b>	42	32	21	16	39680	-		
<b>8000</b>	20,97	69		-	<b>58</b>	40	31	20	15	40071	-		
<b>8000</b>	23,52	62		-	<b>52</b>	36	27	18	14	42417	-		
<b>8000</b>	26,52	55		-	<b>46</b>	32	24	16	12	44953	-		
<b>8000</b>	29,40	49		-	<b>41</b>	29	22	14	11	47214	374		
<b>8000</b>	33,78	43		-	<b>36</b>	25	19	13	9,5	50370	1262		
<b>8000</b>	39,00	37		-	<b>31</b>	22	17	11	8,2	53774	2055		
<b>8000</b>	40,44	36		-	<b>30</b>	21	16	10	7,9	54659	2095		
<b>8000</b>	45,36	32		-	<b>27</b>	19	14	9,3	7,1	55500	2636		
<b>8000</b>	51,13	28		-	<b>24</b>	17	13	8,3	6,3	55500	3136		
<b>8000</b>	58,00	25		-	<b>21</b>	15	11	7,3	5,5	55500	3600		
<b>8000</b>	66,32	22		39	<b>18</b>	13	9,7	6,4	4,8	55500	4030		
<b>8000</b>	76,59	19		34	<b>16</b>	11	8,4	5,5	4,2	55500	4219		
<b>8000</b>	88,57	16		29	<b>14</b>	9,6	7,3	4,8	3,6	55500	4332		
<b>8000</b>	99,00	15		26	<b>12</b>	8,6	6,5	4,3	3,2	55500	4386		
<b>8000</b>	111,63	13		23	<b>11</b>	7,6	5,8	3,8	2,9	55500	4437		
<b>8000</b>	127,11	11	<b>KT774</b>	21	<b>10</b>	6,8	5,2	3,4	2,6	55000	-	370	446
<b>8000</b>	142,56	10		18	<b>9,2</b>	6,0	4,6	3,0	2,3	55000	-		
<b>8000</b>	160,70	9,0		16	<b>8,2</b>	5,4	4,1	2,7	2,0	55000	-		
<b>8000</b>	182,29	8,0		14	<b>7,2</b>	4,7	3,6	2,4	1,8	55000	-		
<b>8000</b>	208,42	7,0		13	<b>6,3</b>	4,2	3,2	2,1	1,6	55000	530		
<b>8000</b>	240,71	6,0		11	<b>5,5</b>	3,6	2,7	1,8	1,4	55000	1265		
<b>8000</b>	278,35	5,2		9,5	<b>4,7</b>	3,1	2,4	1,6	1,2	55000	1628		
<b>8000</b>	311,14	4,7		8,5	<b>4,3</b>	2,8	2,1	1,4	1,1	55000	1663		
<b>8000</b>	354,32	4,1		7,5	<b>3,7</b>	2,4	1,9	1,2	0,93	55000	1694		
<b>8000</b>	396,00	3,7		6,7	<b>3,3</b>	2,2	1,7	1,1	0,83	55000	1647		

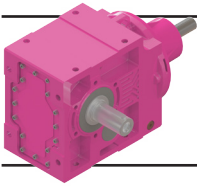

# K Serisi Motorsuz Güç Devir Sayfaları

## K Series Gear Units Performance Tables

### K Serien Getriebe Leistung und Drehzahlübersicht

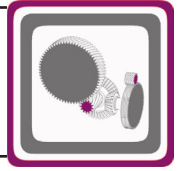

Anma Momenti  Nominal Torques  Nenn-drehmomente  Ma [Nm] (n1=1450rpm)	Çevrim Oranı	Çıkış Devri	Tipi  Type  Typ	Pe= Nominal Güç [kW] (Servis Faktörü fs=1,0 için)						Güv. Rad.Yük Çıkış	Güv.Rad.Yük Giriş	Ağırlık  Weight	Ölçü Sayfası  Dim. Page
	Ratio	Output Speeds		Pe= Nominal Power [kW] (For Service Factor fs=1,0)						Per.O.Loads (Output)	Per.O.Loads (Input)		
	Übersetzung	Abtriebs-drehzahlen		Pe= NennLeistung [kW] (Bei Betriebsfaktor fs=1,0)						Zul.Querkräfte (Abtrieb)	Zul.Querkräfte (Antrieb)	Gewicht  [kg]	Maße Seite
	i	n2 [r.p.m] (n1=1450rpm)		Giriş devri[d/d] / Input speed[rpm] / Antriebsdrehzahl[upm]						Fqam [N] (n1=1450rpm)	Fqem [N] (n1=1450rpm)		
			n1=2900	n1=1450	n1=950	n1=725	n1=475	n1=360					
<b>8000</b>	436,74	3,3	<b>KT775</b>	6,2	<b>3,1</b>	2,0	1,5	1,0	0,77	55000	1746	381	450
<b>8000</b>	504,65	2,9		5,4	<b>2,7</b>	1,8	1,3	0,88	0,67	55000	1771		
<b>8000</b>	547,17	2,7		5,0	<b>2,5</b>	1,6	1,2	0,81	0,62	55000	1786		
<b>8000</b>	655,11	2,2		4,2	<b>2,1</b>	1,4	1,0	0,68	0,52	55000	1810		
<b>8000</b>	746,01	1,9		3,7	<b>1,8</b>	1,2	0,91	0,60	0,45	55000	1826		
<b>8000</b>	833,78	1,7		3,3	<b>1,6</b>	1,1	0,82	0,54	0,41	55000	1839		
<b>8000</b>	943,49	1,5		2,9	<b>1,4</b>	0,95	0,72	0,47	0,36	55000	1851		
<b>8000</b>	1058,16	1,4		2,6	<b>1,3</b>	0,85	0,65	0,42	0,32	55000	1892		
<b>8000</b>	1192,77	1,2		2,3	<b>1,1</b>	0,75	0,57	0,38	0,28	55000	1930		
<b>8000</b>	1353,02	1,1		2,0	<b>1,0</b>	0,66	0,51	0,33	0,25	55000	1966		
<b>8000</b>	1547,01	0,94		1,8	<b>0,88</b>	0,58	0,44	0,29	0,24	55000	2000		
<b>8000</b>	1786,65	0,81		1,5	<b>0,77</b>	0,50	0,38	0,25	0,21	55000	2031		
<b>8000</b>	2066,04	0,70		1,3	<b>0,66</b>	0,43	0,33	0,24	0,18	55000	2058		
<b>8000</b>	2539,01	0,57		1,1	<b>0,54</b>	0,35	0,27	0,20	0,15	55000	2065		
<b>8000</b>	2838,16	0,51		0,97	<b>0,48</b>	0,32	0,27	0,18	0,13	55000	2083		
<b>8000</b>	3203,12	0,45		0,86	<b>0,43</b>	0,28	0,24	0,16	0,12	55000	2086		
<b>8000</b>	1941,39	0,75	<b>KT776</b>	1,4	<b>0,72</b>	0,47	0,36	0,26	0,20	55000	2124	386	450
<b>8000</b>	2145,24	0,68		1,3	<b>0,65</b>	0,43	0,33	0,24	0,18	55000	2129		
<b>8000</b>	2503,73	0,58		1,1	<b>0,56</b>	0,37	0,28	0,20	0,15	55000	2135		
<b>8000</b>	2944,95	0,49		0,95	<b>0,48</b>	0,31	0,26	0,17	0,13	55000	2141		
<b>8000</b>	3501,26	0,41		0,80	<b>0,40</b>	0,26	0,22	0,15	0,11	55000	2146		
<b>8000</b>	3960,44	0,37		0,71	<b>0,35</b>	0,26	0,20	0,13	0,10	55000	2150		
<b>8000</b>	4516,30	0,32		0,62	<b>0,31</b>	0,23	0,17	0,11	0,09	55000	2153		
<b>8000</b>	5610,63	0,26		0,50	<b>0,25</b>	0,18	0,14	0,09	0,07	55000	2157		
<b>8000</b>	6380,72	0,23		0,49	<b>0,25</b>	0,18	0,14	0,09	0,07	55000	2159		
<b>8000</b>	7156,22	0,20		0,44	<b>0,22</b>	0,16	0,12	0,08	0,06	55000	2167		
<b>8000</b>	8066,59	0,18		0,39	<b>0,19</b>	0,14	0,11	0,07	0,05	55000	2174		
<b>8000</b>	9150,37	0,16		0,34	<b>0,17</b>	0,13	0,10	0,06	0,05	55000	2181		
<b>8000</b>	10462,31	0,14		0,30	<b>0,15</b>	0,11	0,08	0,05	0,04	55000	2188		
<b>8000</b>	12082,94	0,12		0,26	<b>0,13</b>	0,09	0,07	0,05	0,04	55000	2194		
<b>8000</b>	13972,49	0,10		0,25	<b>0,11</b>	0,08	0,06	0,04	0,03	55000	2199		
<b>8000</b>	15618,73	0,09		0,22	<b>0,10</b>	0,07	0,06	0,04	0,03	55000	2202		
<b>7850</b>	9,63	151	<b>KT873</b>	-	<b>132</b>	98	77	51	38	59317	-	615	454
<b>8100</b>	11,05	131		-	<b>118</b>	88	67	44	33	62056	-		
<b>8350</b>	12,25	118		-	<b>110</b>	80	61	40	30	64010	-		
<b>8650</b>	13,93	104		-	<b>100</b>	70	53	35	26	66615	-		
<b>12600</b>	16,78	86		-	<b>121</b>	91	72	47	36	64685	-		
<b>13100</b>	19,26	75		-	<b>110</b>	82	63	41	31	67491	-		
<b>13550</b>	21,34	68		-	<b>103</b>	74	57	37	28	69502	-		
<b>14100</b>	24,28	60		-	<b>94</b>	65	50	33	25	72195	-		
<b>13300</b>	29,88	49		-	<b>72</b>	53	41	27	20	81282	-		
<b>13800</b>	34,28	42		-	<b>65</b>	46	35	23	18	84864	-		
<b>14250</b>	38,00	38		-	<b>61</b>	42	32	21	16	85187	-		
<b>14750</b>	43,22	34		-	<b>55</b>	37	28	18	14	80404	-		
<b>15000</b>	49,75	29		-	<b>49</b>	32	24	16	12	76000	-		
<b>15000</b>	55,53	26		-	<b>44</b>	29	22	14	11	76000	-		
<b>15000</b>	62,42	23		-	<b>39</b>	25	19	13	9,6	76000	-		
<b>15000</b>	70,76	20		63	<b>34</b>	22	17	11	8,5	76000	-		
<b>15000</b>	81,06	18	57	<b>30</b>	20	15	9,8	7,4	76000	-			
<b>15000</b>	92,80	16	52	<b>26</b>	17	13	8,6	6,5	76000	-			
<b>15000</b>	103,24	14	47	<b>23</b>	15	12	7,7	5,8	76000	-			
<b>15000</b>	115,87	13	42	<b>21</b>	14	10	6,8	5,2	76000	-			
<b>15000</b>	86,63	17	<b>KT874</b>	56	<b>28</b>	18	14	9,2	7,0	76000	-	630	458
<b>15000</b>	98,53	15		50	<b>25</b>	16	12	8,1	6,2	76000	-		
<b>15000</b>	113,42	13		43	<b>22</b>	14	11	7,1	5,4	76000	-		
<b>15000</b>	126,62	11		39	<b>19</b>	13	9,7	6,3	4,8	76000	-		
<b>15000</b>	142,32	10		34	<b>17</b>	11	8,6	5,6	4,3	76000	-		
<b>15000</b>	161,34	9,0		30	<b>15</b>	10,0	7,6	5,0	3,8	76000	175		
<b>15000</b>	184,83	7,8		27	<b>13</b>	8,7	6,7	4,4	3,3	76000	1361		
<b>15000</b>	207,95	7,0		24	<b>12</b>	7,8	5,9	3,9	2,9	76000	1664		
<b>15000</b>	235,47	6,2		21	<b>10</b>	6,9	5,2	3,4	2,6	76000	1948		

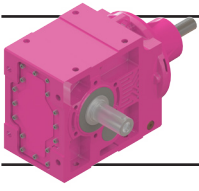

# K Serisi Motorsuz Güç Devir Sayfaları

## K Series Gear Units Performance Tables

### K Serien Getriebe Leistung und Drehzahlübersicht

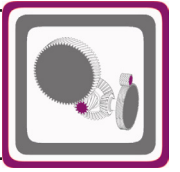

Anma Momenti <i>Nominal Torques</i> Nenn-drehmomente Ma [Nm] (n1=1450rpm)	Çevrim Oranı	Çıkış Devri	Tipi	Pe= Nominal Güç [kW] (Servis Faktörü fs=1,0 için)						Güv. Rad.Yük Çıkış <i>Per.O.Loads (Output)</i>	Güv.Rad.Yük Giriş <i>Per.O.Loads (Input)</i>	Ağırlık <i>Weight</i>	Ölçü Sayfası <i>Dim. Page</i>
	Ratio	Output Speeds		Type	Pe= NennLeistung [kW] (Bei Betriebsfaktor fs=1,0)								
	Übersetzung	Abtriebs-drehzahlen	Typ	Giriş devri[d/d] / Input speed[rpm] / Antriebsdrehzahl[upm]						Zul.Querkräfte (Abtrieb)	Zul.Querkräfte (Antrieb)	Gewicht	Maße Seite
	i	n2 [r.p.m] (n1=1450rpm)		n1=2900	n1=1450	n1=950	n1=725	n1=475	n1=360				
<b>15000</b>	287,10	5,1	<b>KT874</b>	17	<b>8,6</b>	5,6	4,3	2,8	2,1	76000	2311	630	458
<b>15000</b>	339,70	4,3		15	<b>7,3</b>	4,8	3,6	2,4	1,8	76000	2584		
<b>15000</b>	383,99	3,8		13	<b>6,5</b>	4,2	3,2	2,1	1,6	76000	2648		
<b>15000</b>	438,70	3,3		11	<b>5,7</b>	3,7	2,8	1,9	1,4	76000	2688		
<b>15000</b>	463,83	3,1	<b>KT875</b>	11	<b>5,5</b>	3,6	2,7	1,8	1,4	76000	695	640	462
<b>15000</b>	514,05	2,8		9,9	<b>4,9</b>	3,2	2,5	1,6	1,2	76000	1122		
<b>15000</b>	584,66	2,5		8,7	<b>4,3</b>	2,8	2,2	1,4	1,1	76000	1448		
<b>15000</b>	673,01	2,2		7,5	<b>3,8</b>	2,5	1,9	1,2	0,94	76000	1551		
<b>15000</b>	751,30	1,9		6,8	<b>3,4</b>	2,2	1,7	1,1	0,84	76000	1622		
<b>15000</b>	844,51	1,7		6,0	<b>3,0</b>	2,0	1,5	0,99	0,75	76000	1690		
<b>15000</b>	957,34	1,5		5,3	<b>2,7</b>	1,7	1,3	0,87	0,66	76000	1754		
<b>15000</b>	1096,71	1,3		4,6	<b>2,3</b>	1,5	1,2	0,76	0,58	76000	1814		
<b>15000</b>	1313,07	1,1		3,9	<b>1,9</b>	1,3	0,97	0,64	0,48	76000	1838		
<b>15000</b>	1495,27	0,97		3,4	<b>1,7</b>	1,1	0,86	0,56	0,42	76000	1852		
<b>15000</b>	1671,18	0,87		3,1	<b>1,5</b>	1,0	0,77	0,50	0,38	76000	1865		
<b>15000</b>	1891,08	0,77		2,7	<b>1,4</b>	0,89	0,68	0,44	0,34	76000	1875		
<b>15000</b>	2074,42	0,70	<b>KT876</b>	2,5	<b>1,3</b>	0,83	0,63	0,41	0,31	76000	2042	650	462
<b>15000</b>	2387,89	0,61		2,2	<b>1,1</b>	0,72	0,55	0,36	0,27	76000	2067		
<b>15000</b>	2665,68	0,54		2,0	<b>0,98</b>	0,64	0,49	0,32	0,27	76000	2085		
<b>15000</b>	2996,39	0,48		1,7	<b>0,87</b>	0,57	0,44	0,29	0,24	76000	2101		
<b>15000</b>	3396,71	0,43		1,5	<b>0,77</b>	0,50	0,39	0,25	0,21	76000	2116		
<b>15000</b>	3891,23	0,37		1,3	<b>0,67</b>	0,44	0,34	0,24	0,19	76000	2131		
<b>15000</b>	4299,81	0,34		1,2	<b>0,61</b>	0,40	0,30	0,22	0,17	76000	2136		
<b>15000</b>	5018,35	0,29		1,0	<b>0,52</b>	0,34	0,26	0,19	0,14	76000	2142		
<b>15000</b>	5902,70	0,25		0,89	<b>0,45</b>	0,29	0,25	0,16	0,12	76000	2147		
<b>15000</b>	7017,76	0,21		0,75	<b>0,38</b>	0,27	0,21	0,14	0,10	76000	2152		
<b>15000</b>	7938,12	0,18		0,67	<b>0,33</b>	0,24	0,18	0,12	0,09	76000	2155		
<b>15000</b>	9052,24	0,16		0,58	<b>0,29</b>	0,21	0,16	0,11	0,08	76000	2158		
<b>15000</b>	11245,67	0,13		0,52	<b>0,26</b>	0,19	0,15	0,10	0,07	76000	2162		
<b>15000</b>	12789,19	0,11		0,46	<b>0,23</b>	0,17	0,13	0,08	0,06	76000	2164		



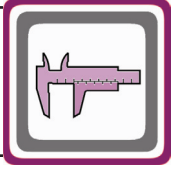
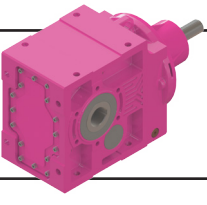

# Ölçü Sayfaları

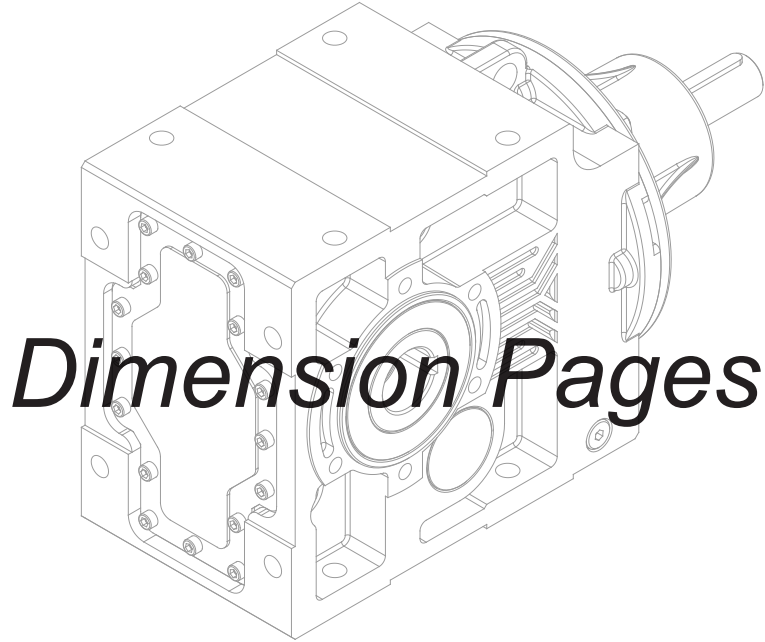

Abmessungsseiten



# Ölçü Sayfaları

## Dimension Pages

### Abmessungenseiten

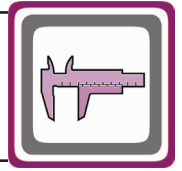

-Mil ucu çektirme deliği DIN 332 sayfa 2 / Tapped center hole to DIN 332, sheet 2 / Zentrierung mit Gewinde DIN 332, Blatt 2

KT002.00  
KT003.00

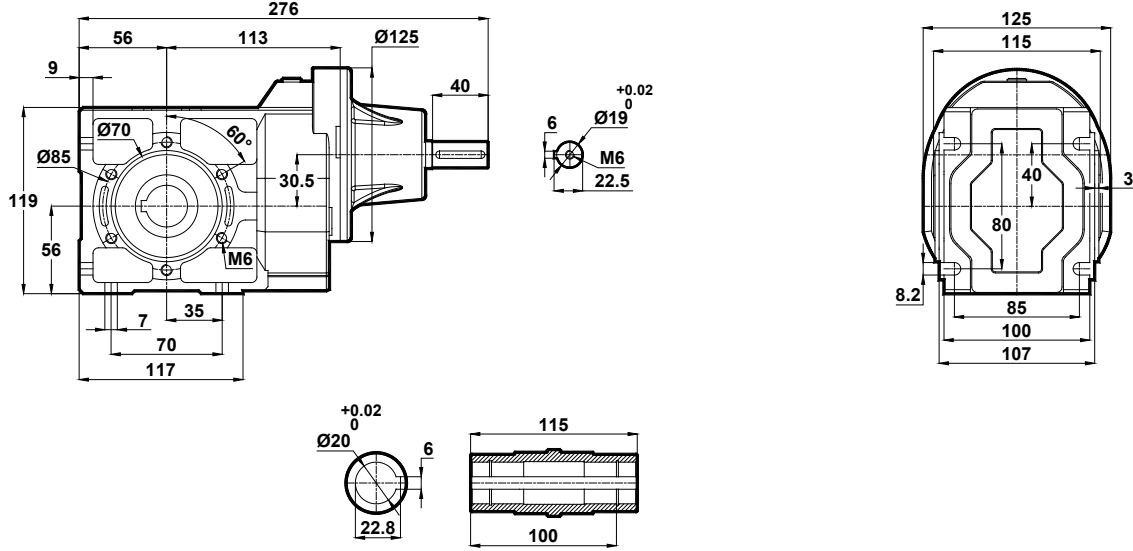

KT002.01  
KT003.01

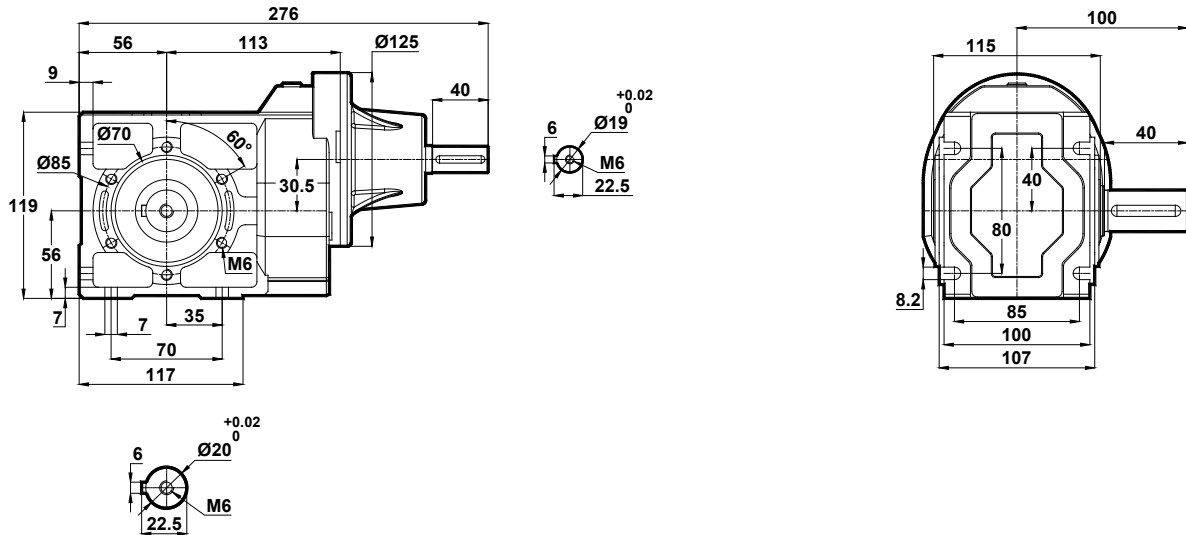

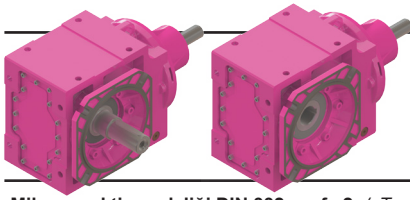

# Ölçü Sayfaları

## Dimension Pages

## Abmessungsseiten

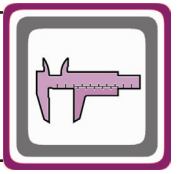

-Mil ucu çekirme deliği DIN 332 sayfa 2 / Tapped center hole to DIN 332, sheet 2 / Zentrierung mit Gewinde DIN 332, Blatt 2

KT002.02  
KT003.02

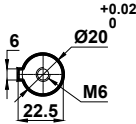
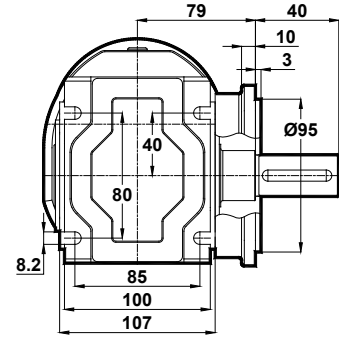
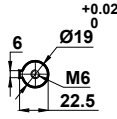
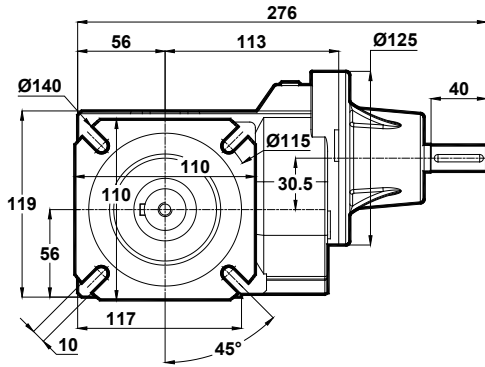

KT002.03  
KT003.03

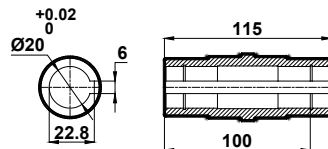
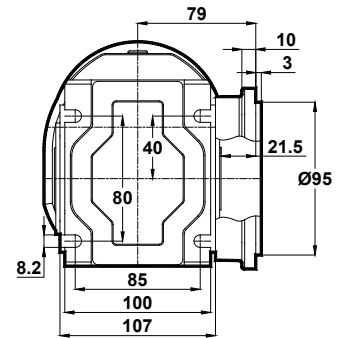
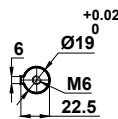
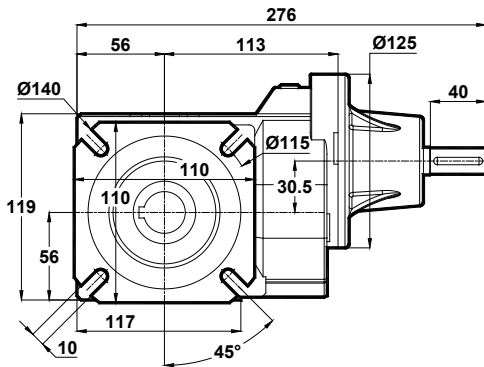

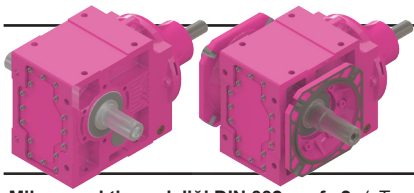

# Ölçü Sayfaları Dimension Pages Abmessungenseiten

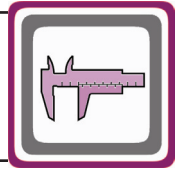

-Mil ucu çekirme deliği DIN 332 sayfa 2 / Tapped center hole to DIN 332, sheet 2 / Zentrierung mit Gewinde DIN 332, Blatt 2

KT002.04  
KT003.04

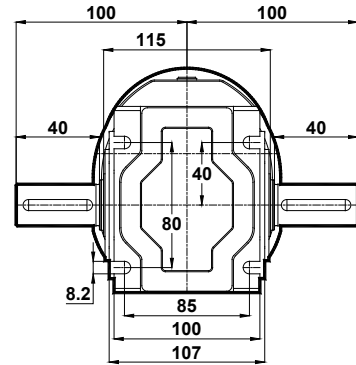
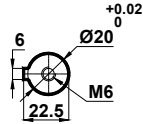
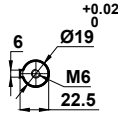
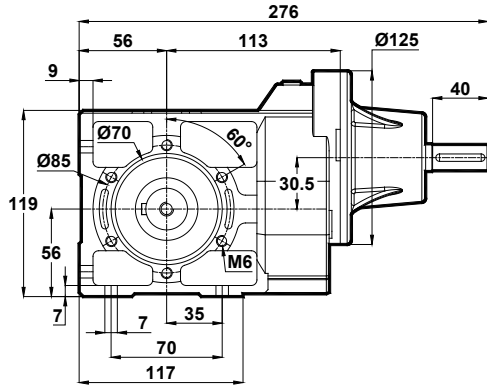

KT002.05  
KT003.05

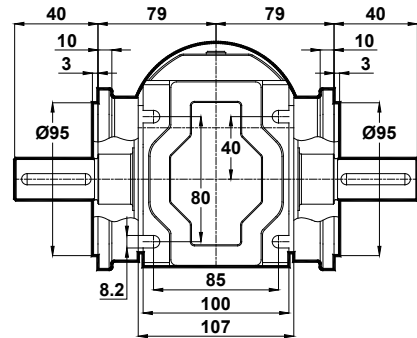
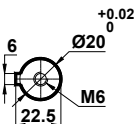
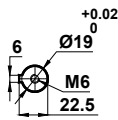
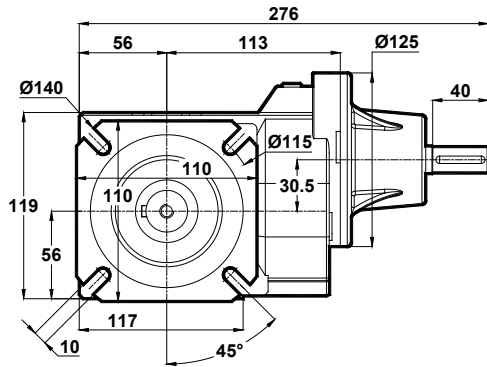





# Ölçü Sayfaları

## Dimension Pages

### Abmessungsseiten



-Mil ucu çektirme deliği DIN 332 sayfa 2 / Tapped center hole to DIN 332, sheet 2 / Zentrierung mit Gewinde DIN 332, Blatt 2

KT002.08  
KT003.08

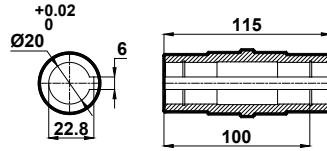
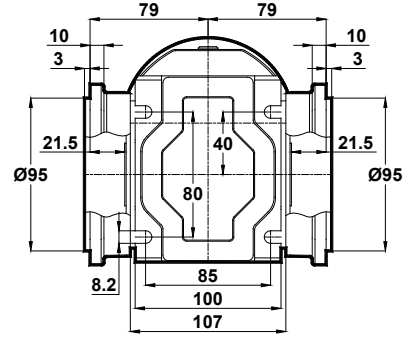
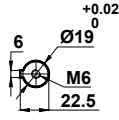
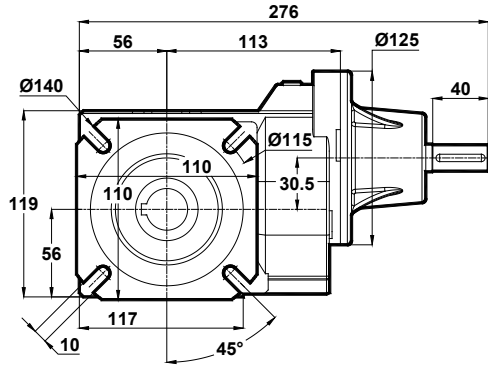



# Ölçü Sayfaları

## Dimension Pages

### Abmessungsseiten

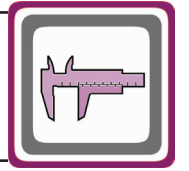

-Mil ucu çekirme deliği DIN 332 sayfa 2 / Tapped center hole to DIN 332, sheet 2 / Zentrierung mit Gewinde DIN 332, Blatt 2

KT102.00  
KT103.00

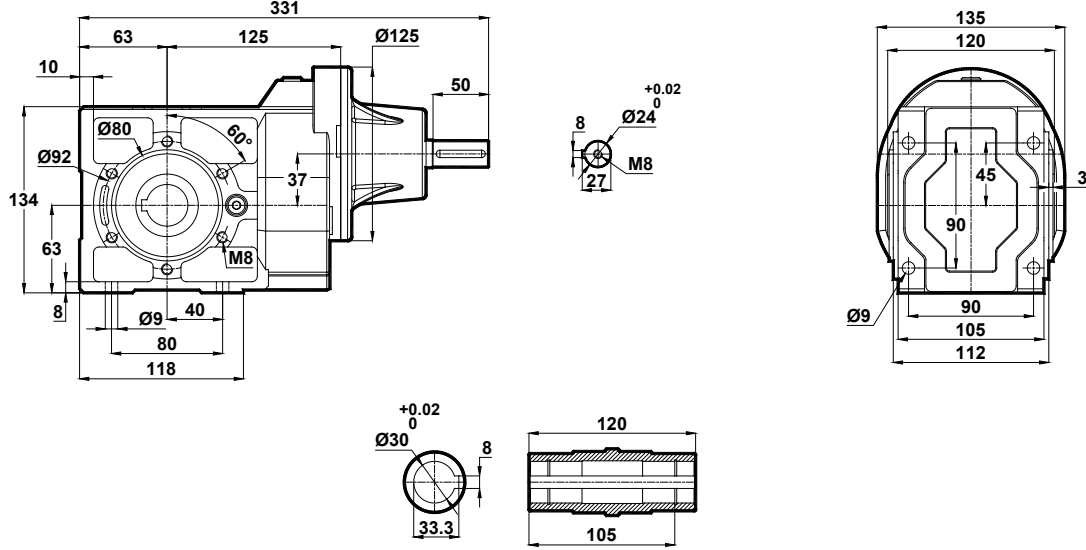

KT102.01  
KT103.01

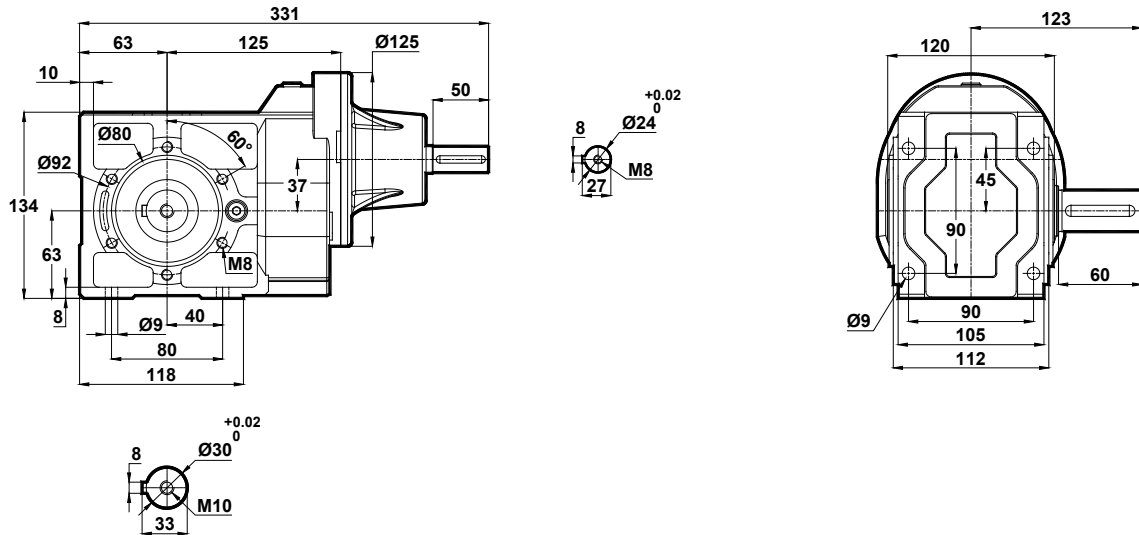



# Ölçü Sayfaları

## Dimension Pages

### Abmessungsseiten



-Mil ucu çektirme deliği DIN 332 sayfa 2 / Tapped center hole to DIN 332, sheet 2 / Zentrierung mit Gewinde DIN 332, Blatt 2

KT102.02  
KT103.02

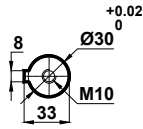
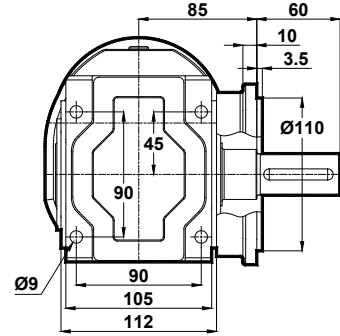
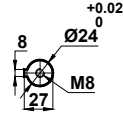
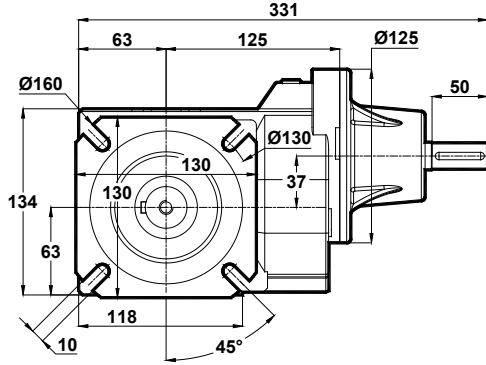

KT102.03  
KT103.03

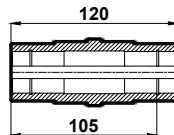
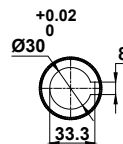
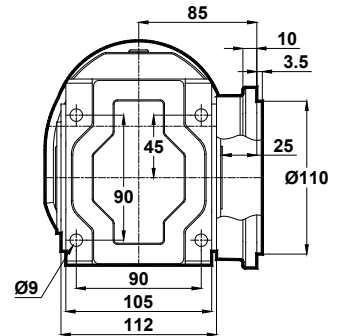
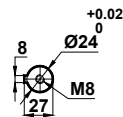
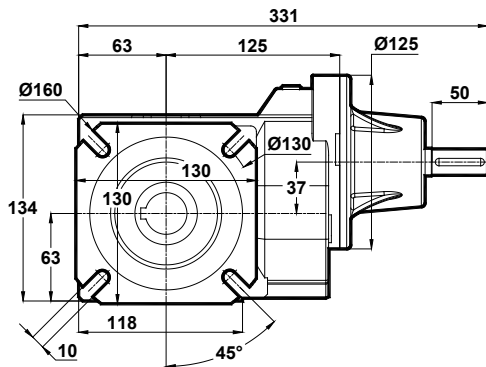

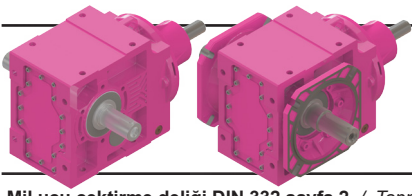

# Ölçü Sayfaları Dimension Pages Abmessungsseiten

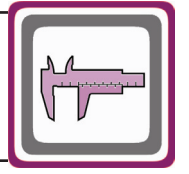

-Mil ucu çekirme deliği DIN 332 sayfa 2 / Tapped center hole to DIN 332, sheet 2 / Zentrierung mit Gewinde DIN 332, Blatt 2

KT102.04  
KT103.04

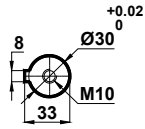
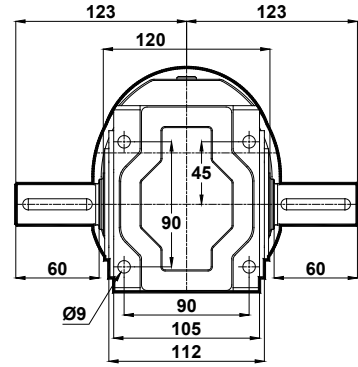
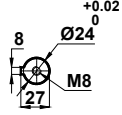
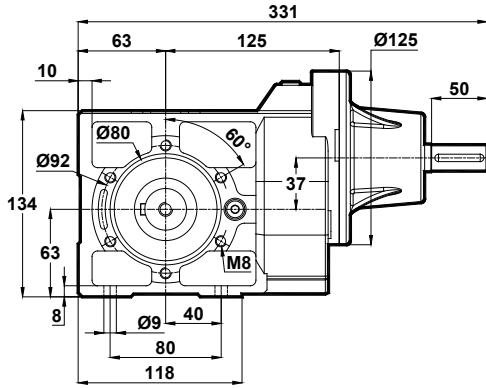

KT102.05  
KT103.05

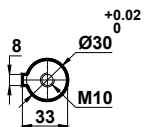
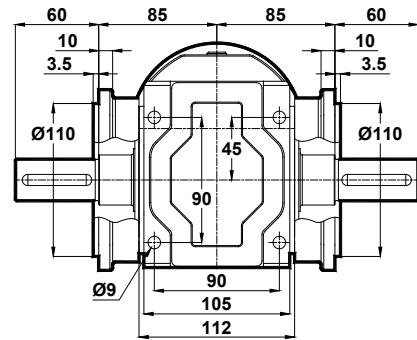
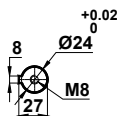
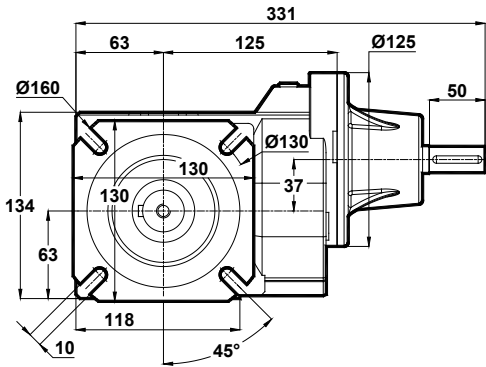



# Ölçü Sayfaları

## Dimension Pages

### Abmessungsseiten



-Mil ucu çekirme deliği DIN 332 sayfa 2 / Tapped center hole to DIN 332, sheet 2 / Zentrierung mit Gewinde DIN 332, Blatt 2

KT102.08  
KT103.08

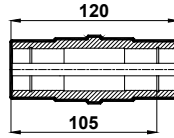
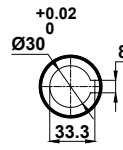
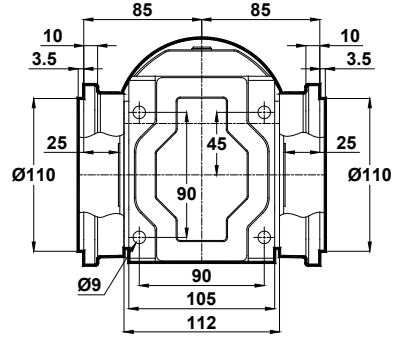
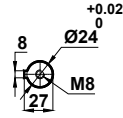
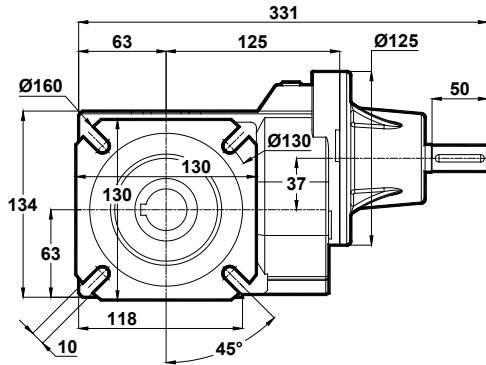



# Ölçü Sayfaları

## Dimension Pages

### Abmessungenseiten

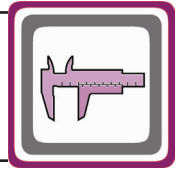

-Mil ucu çekirme deliği DIN 332 sayfa 2 / Tapped center hole to DIN 332, sheet 2 / Zentrierung mit Gewinde DIN 332, Blatt 2

KT202.00  
KT203.00

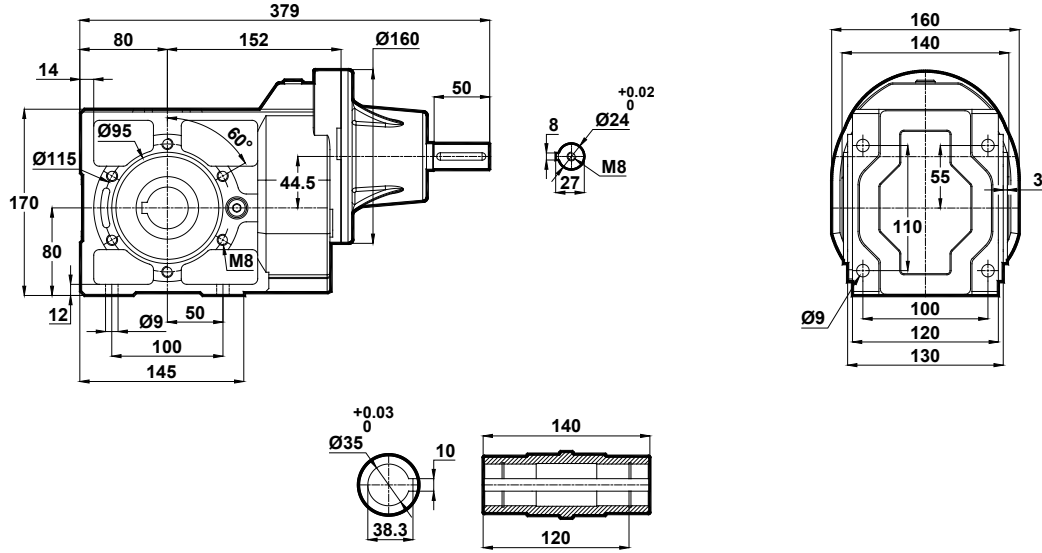

KT202.01  
KT203.01

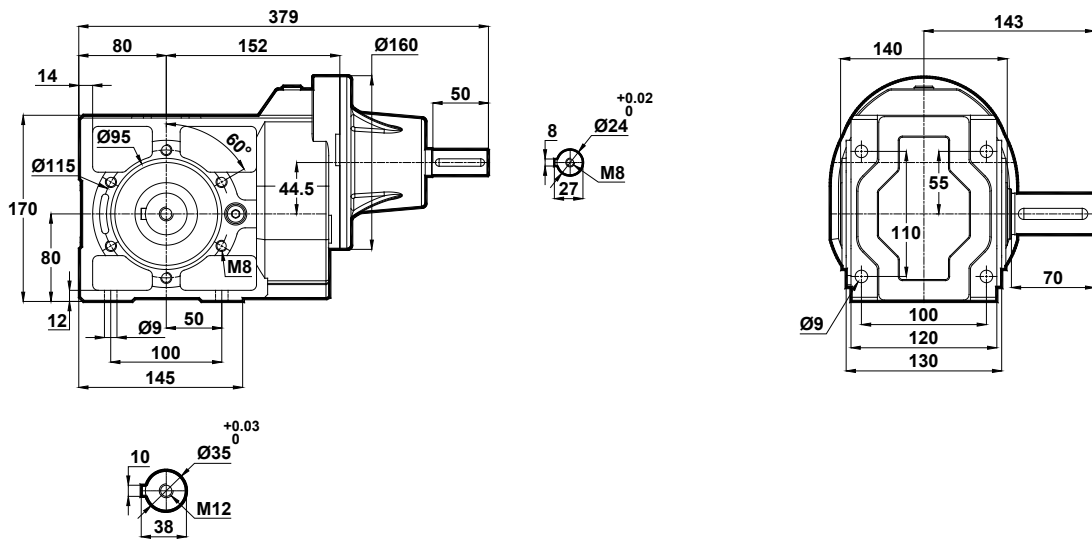



# Ölçü Sayfaları

## Dimension Pages

### Abmessungsseiten



-Mil ucu çekirme deliği DIN 332 sayfa 2 / Tapped center hole to DIN 332, sheet 2 / Zentrierung mit Gewinde DIN 332, Blatt 2

KT202.02  
KT203.02

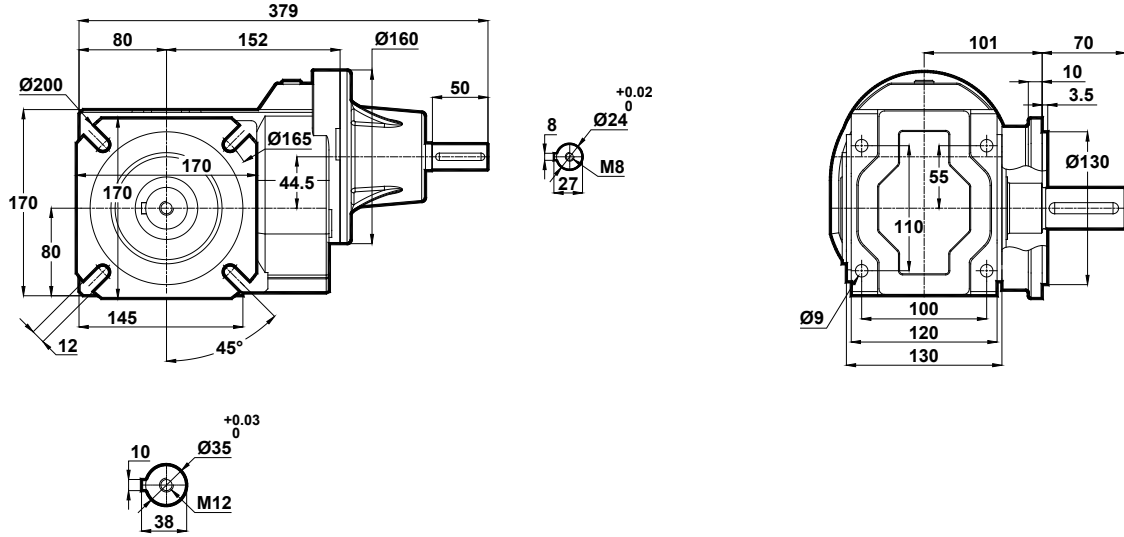

KT202.03  
KT203.03

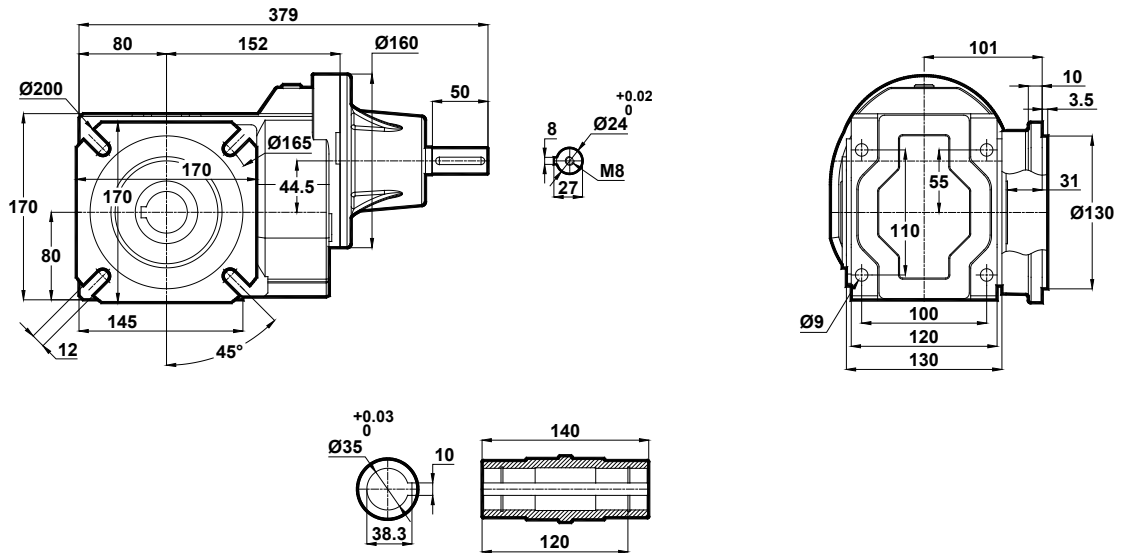

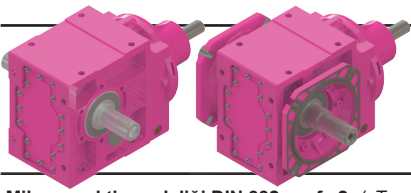

# Ölçü Sayfaları

## Dimension Pages

## Abmessungsseiten

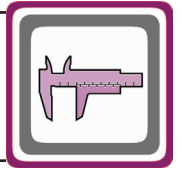

-Mil ucu çekirme deliği DIN 332 sayfa 2 / Tapped center hole to DIN 332, sheet 2 / Zentrierung mit Gewinde DIN 332, Blatt 2

KT202.04  
KT203.04

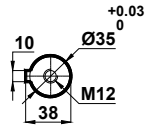
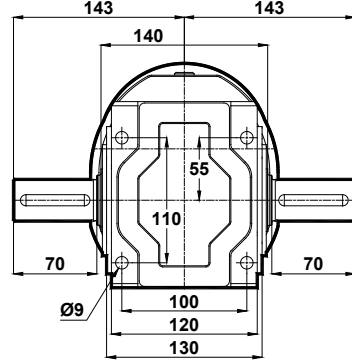
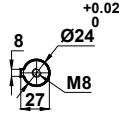
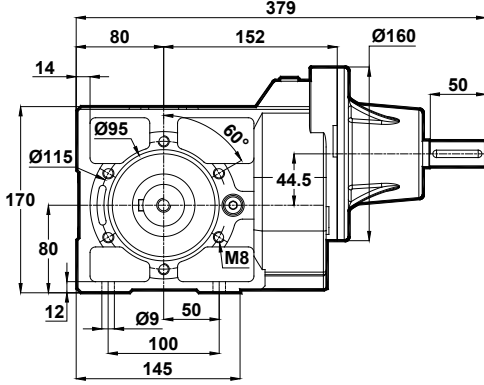

KT202.05  
KT203.05

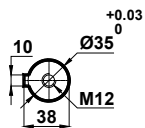
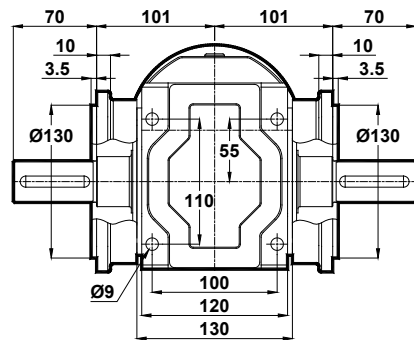
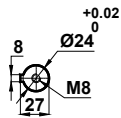
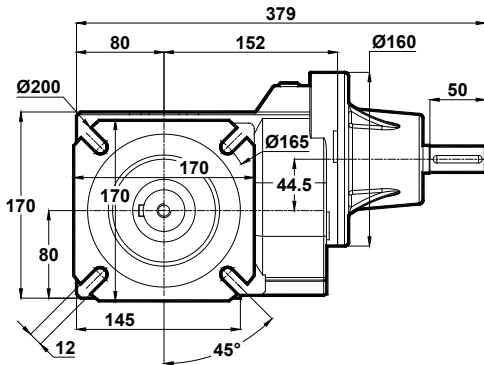





# Ölçü Sayfaları Dimension Pages Abmessungenseiten



-Mil ucu çekirme deliği DIN 332 sayfa 2 / Tapped center hole to DIN 332, sheet 2 / Zentrierung mit Gewinde DIN 332, Blatt 2

KT202.08  
KT203.08

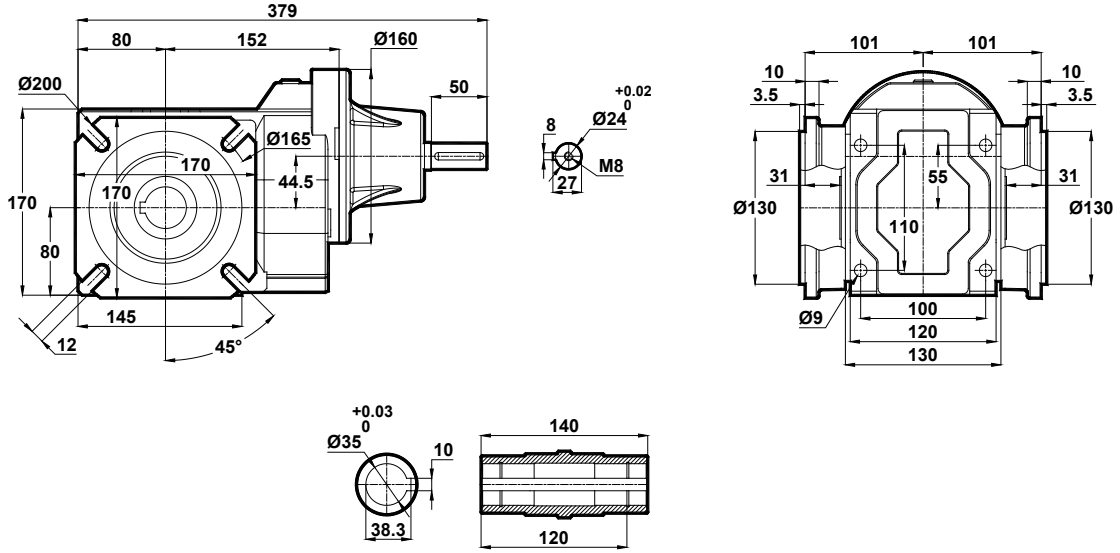



# Ölçü Sayfaları

## Dimension Pages

### Abmessungsseiten

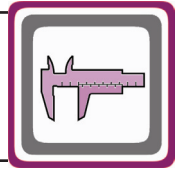

-Mil ucu çekirme deliği DIN 332 sayfa 2 / Tapped center hole to DIN 332, sheet 2 / Zentrierung mit Gewinde DIN 332, Blatt 2

#### KT273.00

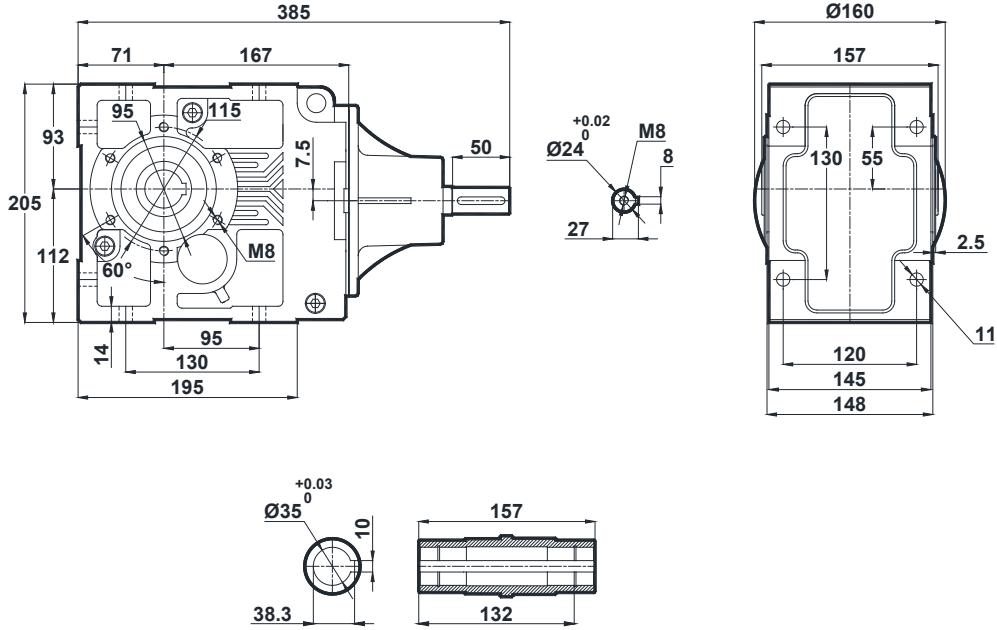

#### KT273.01

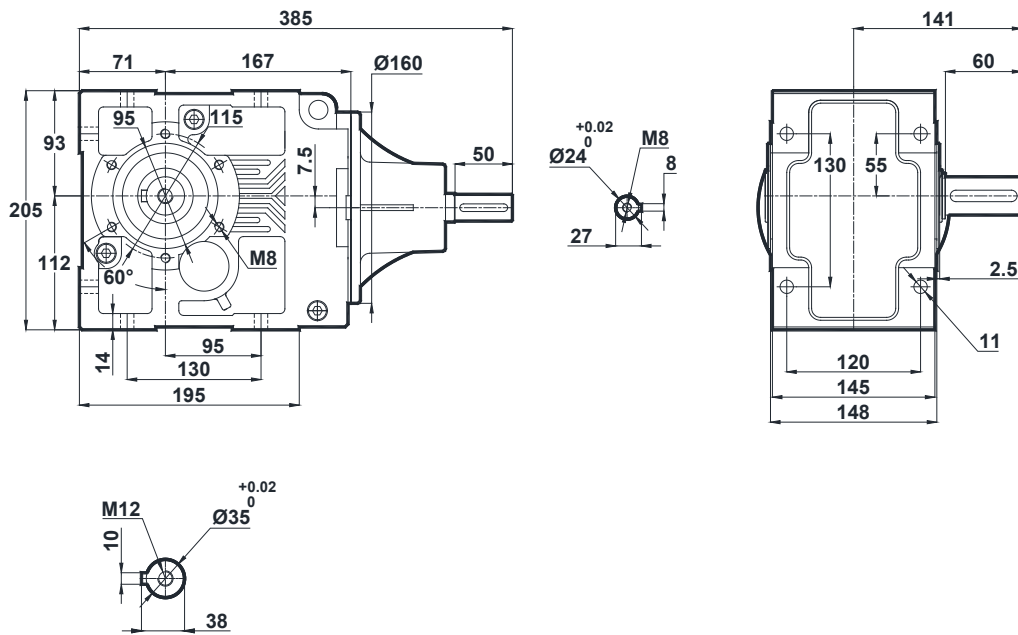

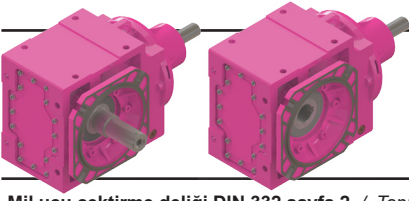

# Ölçü Sayfaları

## Dimension Pages

### Abmessungsseiten



-Mil ucu çektirme deliği DIN 332 sayfa 2 / Tapped center hole to DIN 332, sheet 2 / Zentrierung mit Gewinde DIN 332, Blatt 2

#### KT273.02

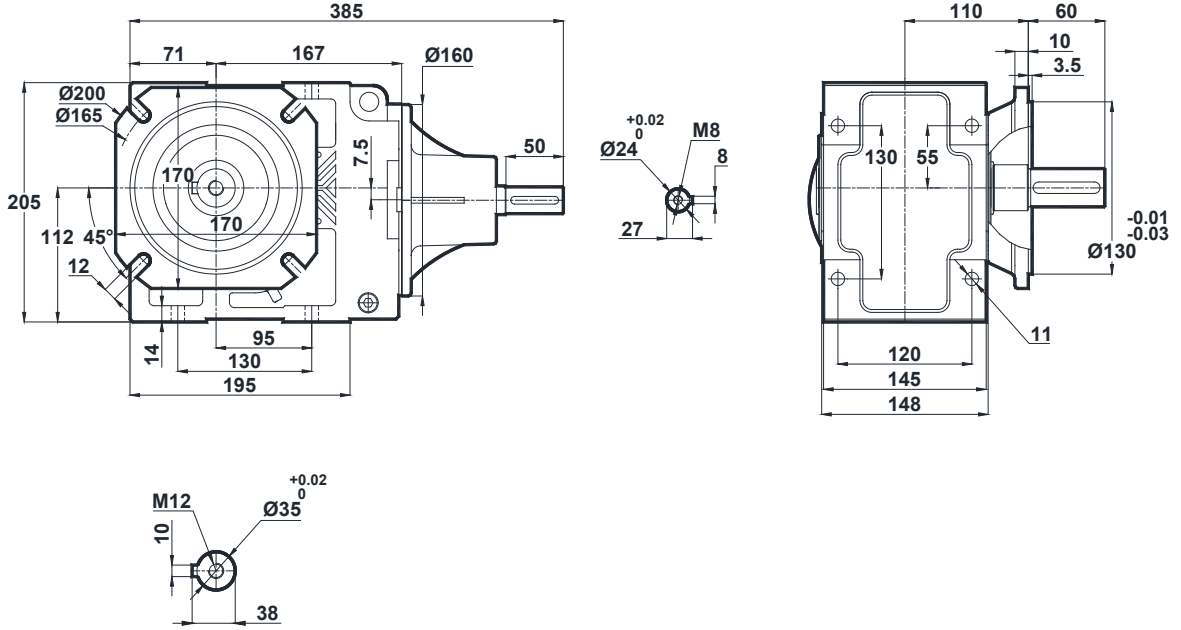

#### KT273.03

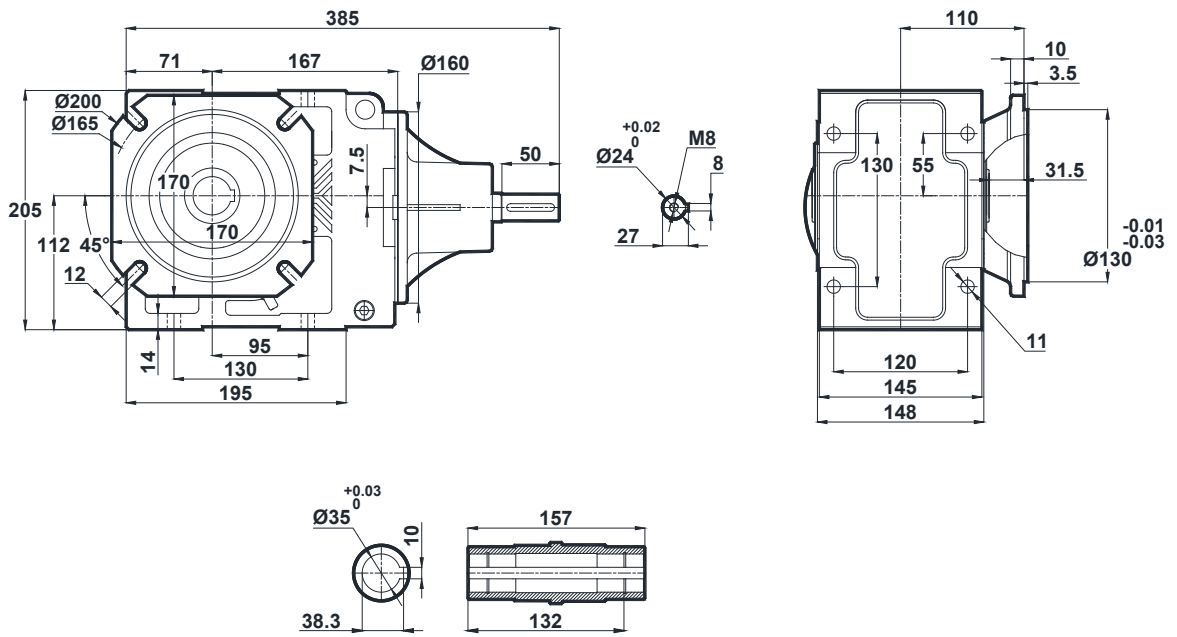

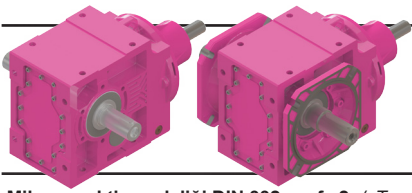

# Ölçü Sayfaları

## Dimension Pages

### Abmessungsseiten

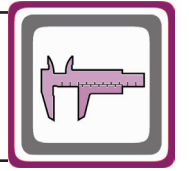

-Mil ucu çekirme deliği DIN 332 sayfa 2 / Tapped center hole to DIN 332, sheet 2 / Zentrierung mit Gewinde DIN 332, Blatt 2

#### KT273.04

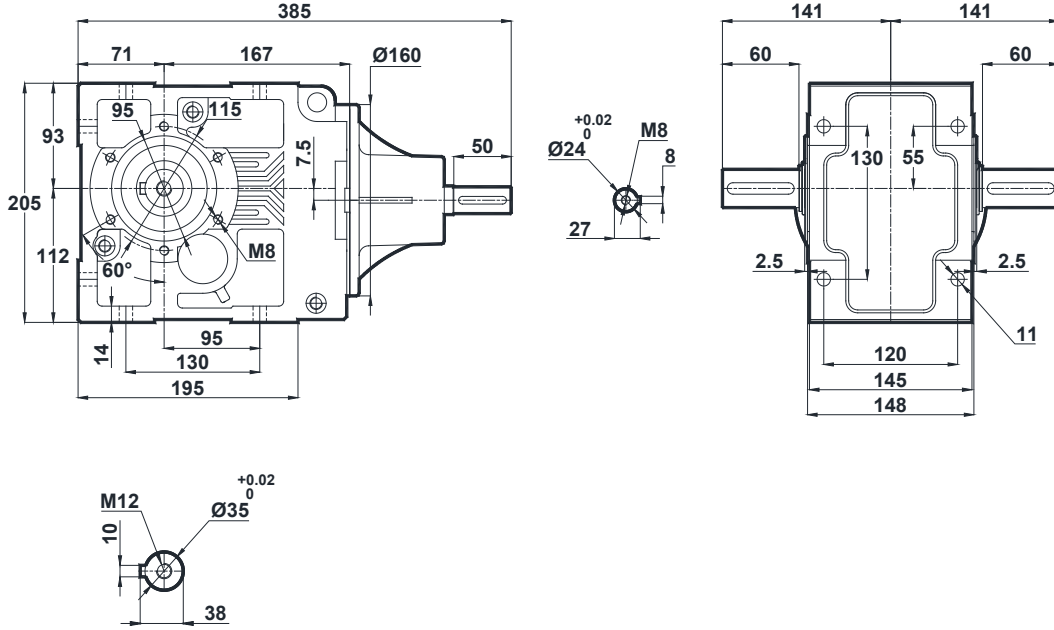

#### KT273.05

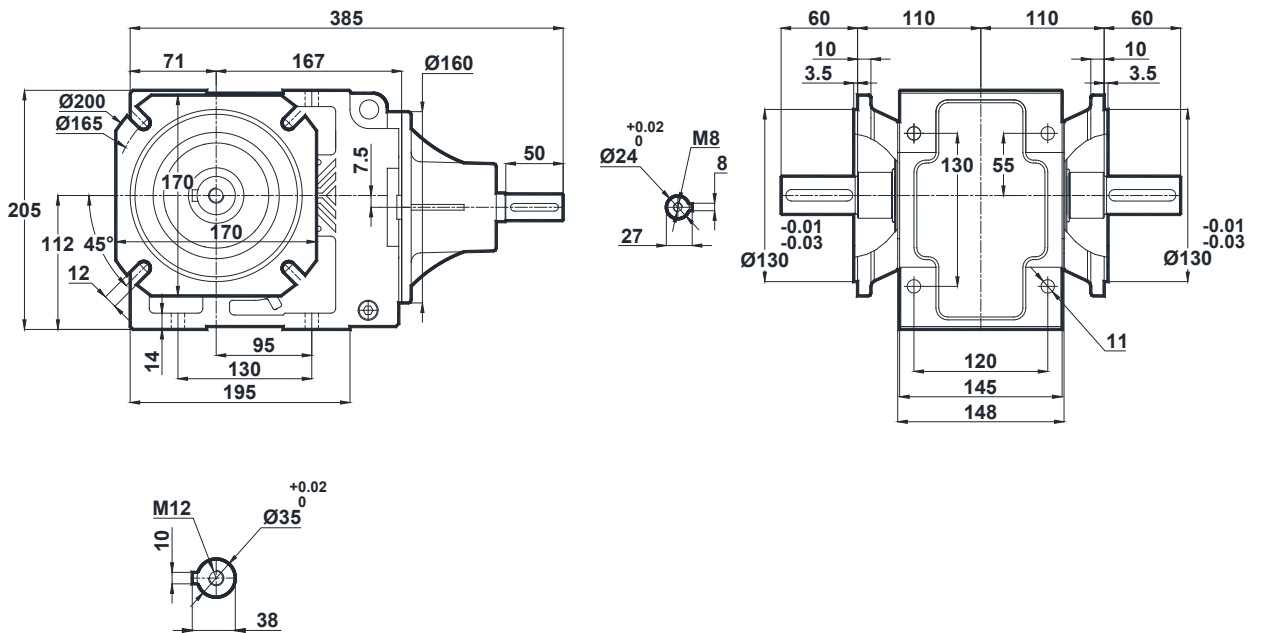



# Ölçü Sayfaları Dimension Pages Abmessungenseiten



-Mil ucu çekirme deliği DIN 332 sayfa 2 / Tapped center hole to DIN 332, sheet 2 / Zentrierung mit Gewinde DIN 332, Blatt 2

KT273.08

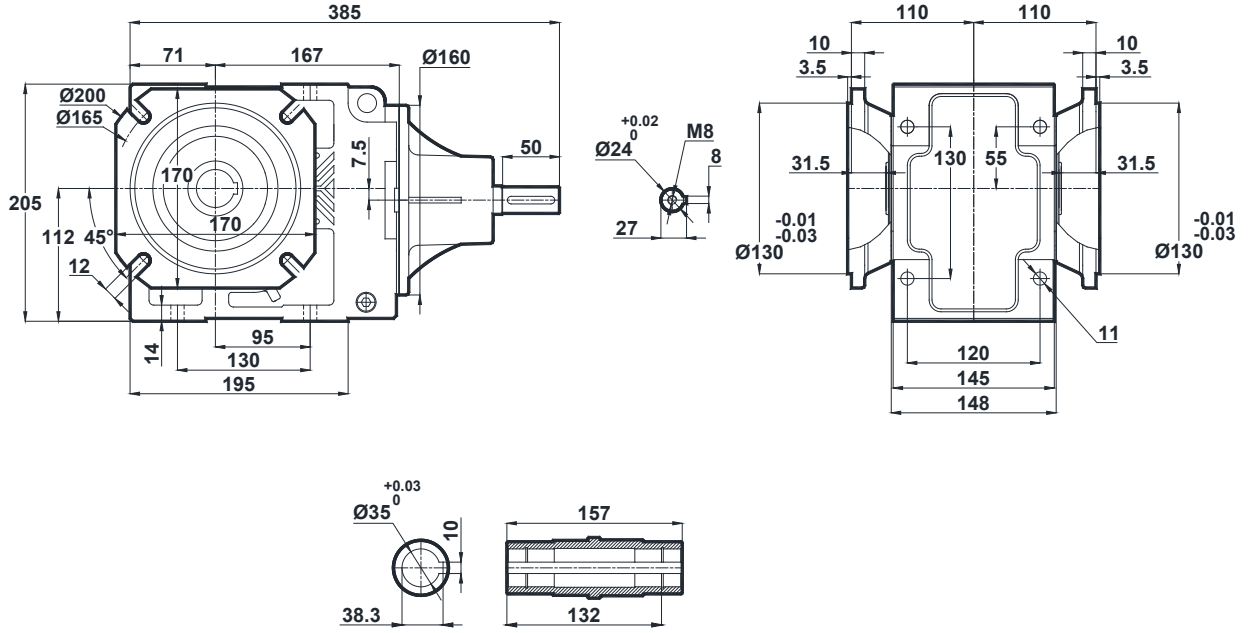



# Ölçü Sayfaları

## Dimension Pages

### Abmessungsseiten

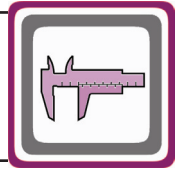

-Mil ucu çekirme deliği DIN 332 sayfa 2 / Tapped center hole to DIN 332, sheet 2 / Zentrierung mit Gewinde DIN 332, Blatt 2

KT275.00  
KT276.00

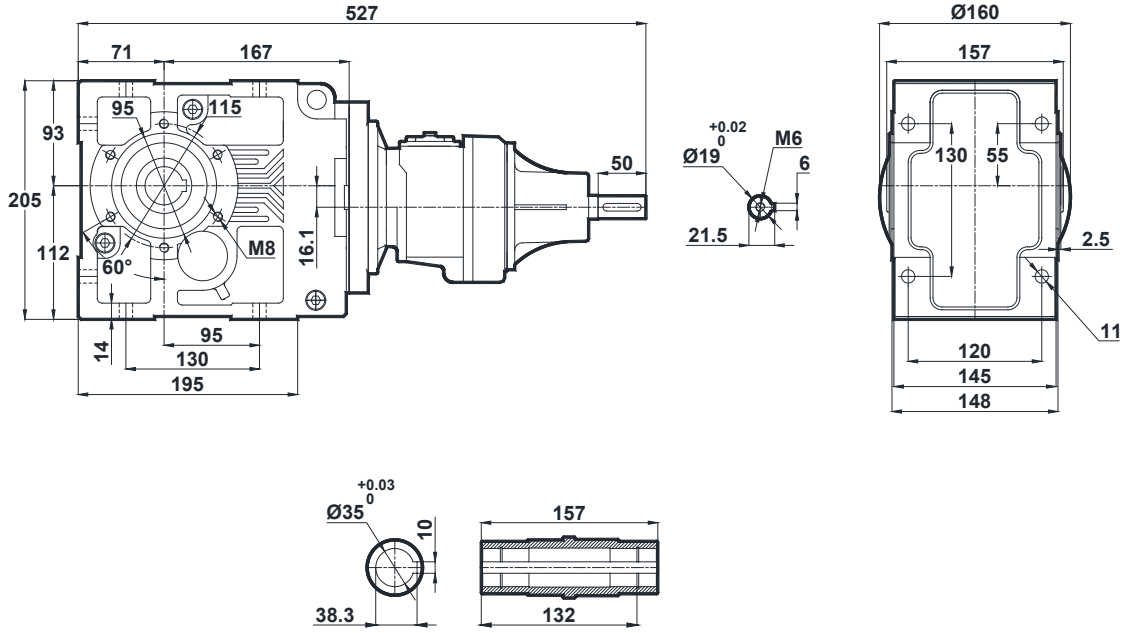

KT275.01  
KT276.01

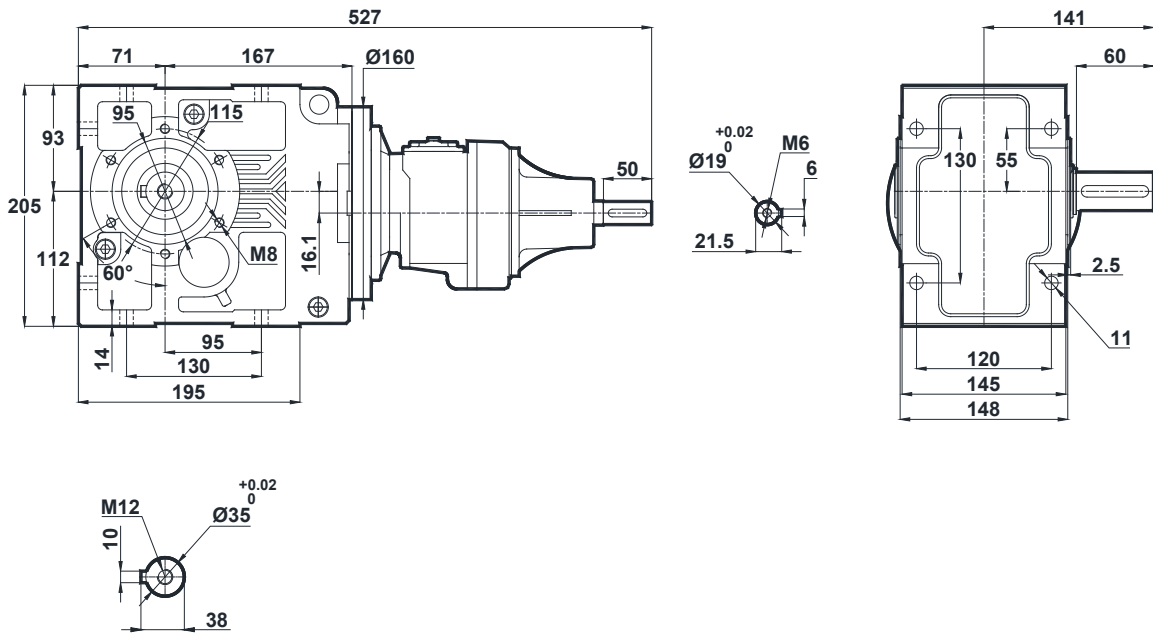



# Ölçü Sayfaları

## Dimension Pages

### Abmessungsseiten

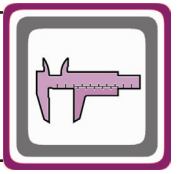

-Mil ucu çekirme deliği DIN 332 sayfa 2 / Tapped center hole to DIN 332, sheet 2 / Zentrierung mit Gewinde DIN 332, Blatt 2

KT275.02  
KT276.02

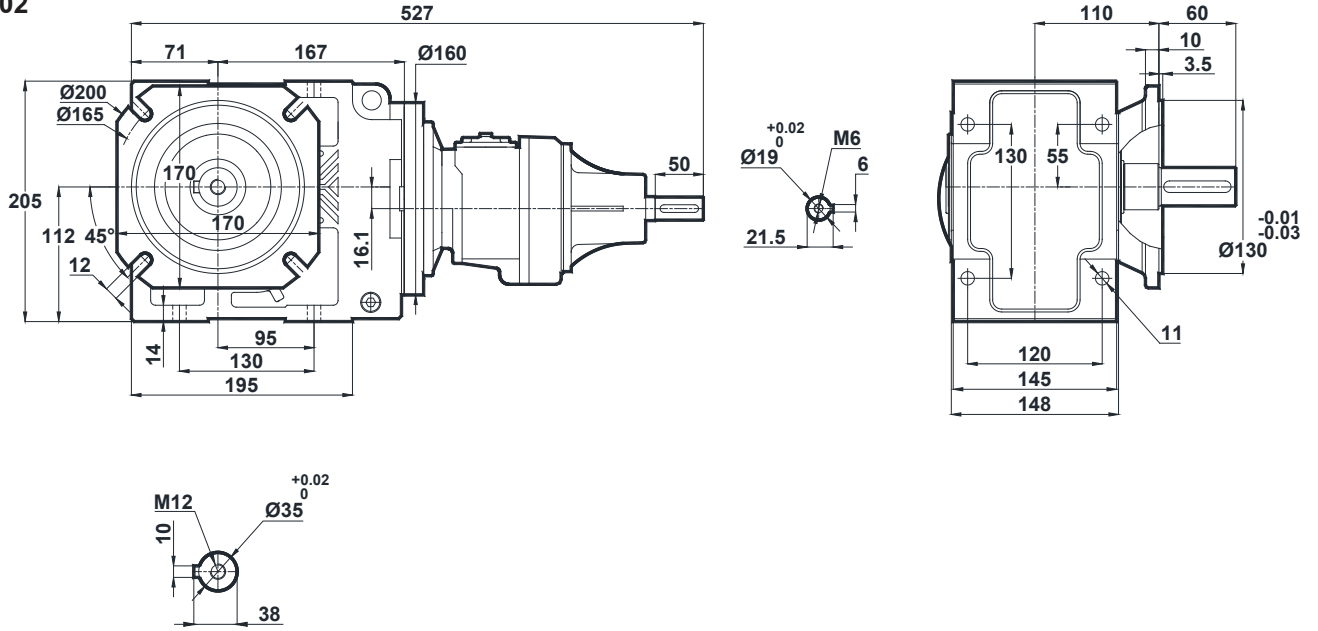

KT275.03  
KT276.03

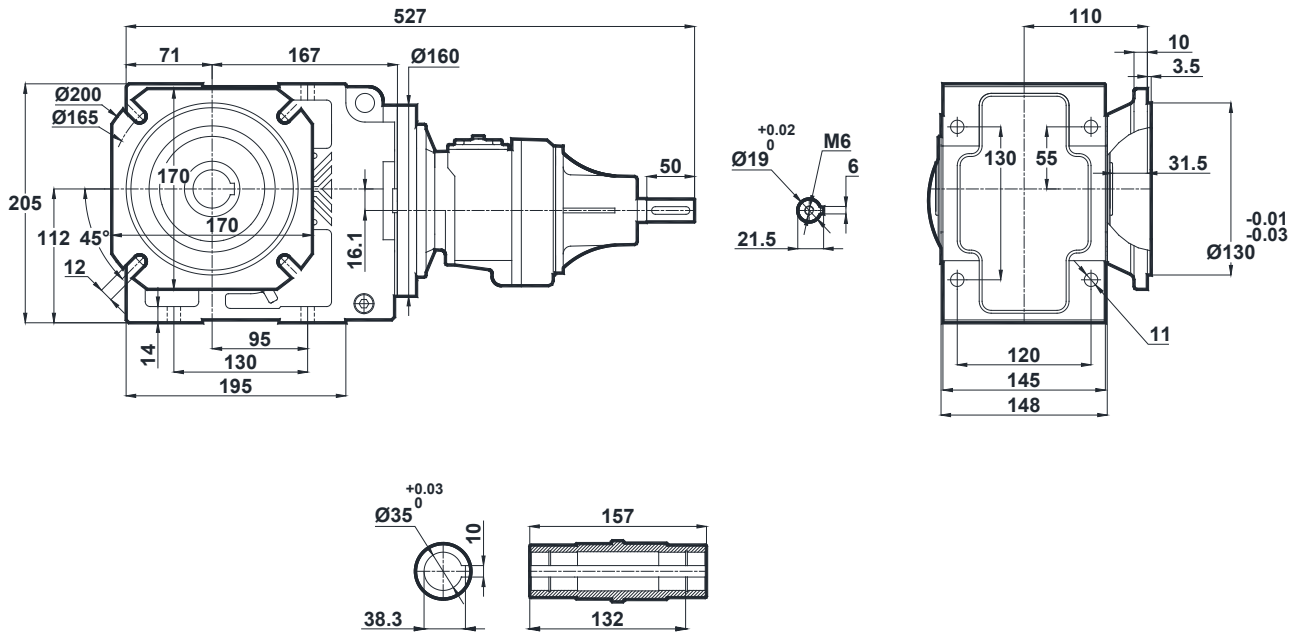

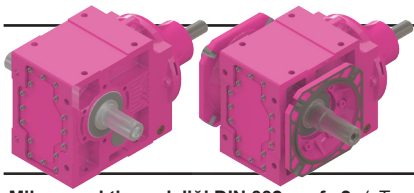

# Ölçü Sayfaları

## Dimension Pages

### Abmessungenseiten

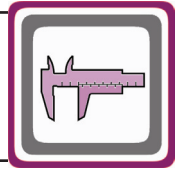

-Mil ucu çektirme deliği DIN 332 sayfa 2 / Tapped center hole to DIN 332, sheet 2 / Zentrierung mit Gewinde DIN 332, Blatt 2

KT275.04  
KT276.04

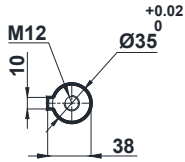
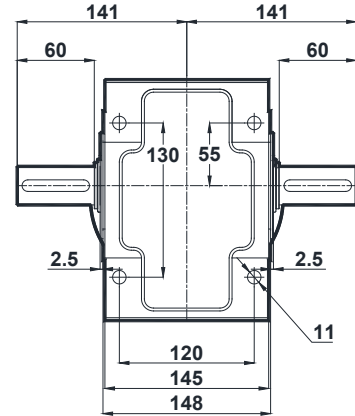
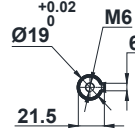
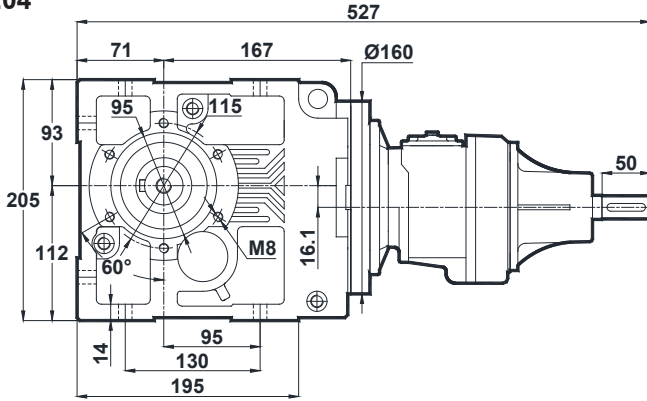

KT275.05  
KT276.05

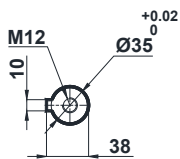
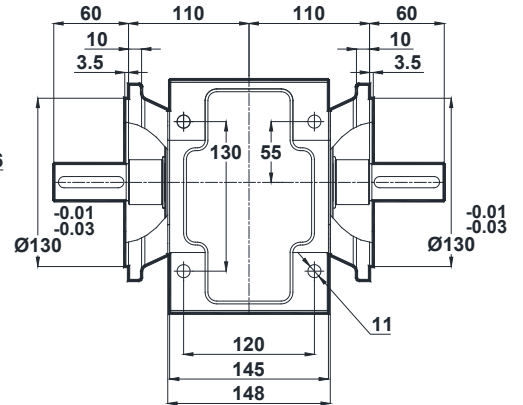
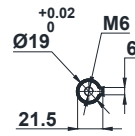
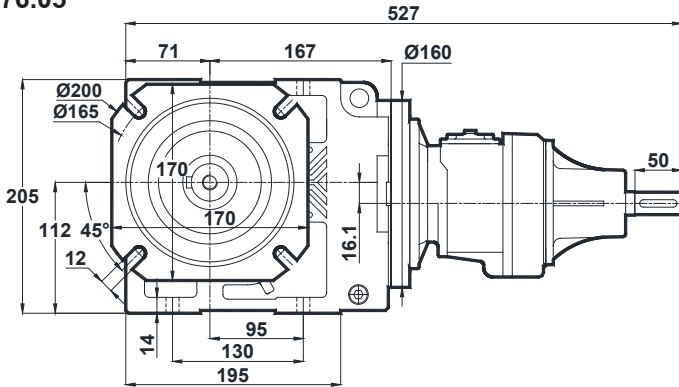





# Ölçü Sayfaları Dimension Pages Abmessungsseiten



-Mil ucu çekirme deliği DIN 332 sayfa 2 / Tapped center hole to DIN 332, sheet 2 / Zentrierung mit Gewinde DIN 332, Blatt 2

KT275.08  
KT276.08

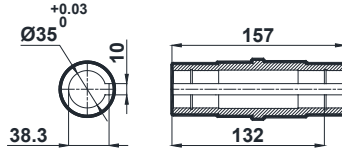
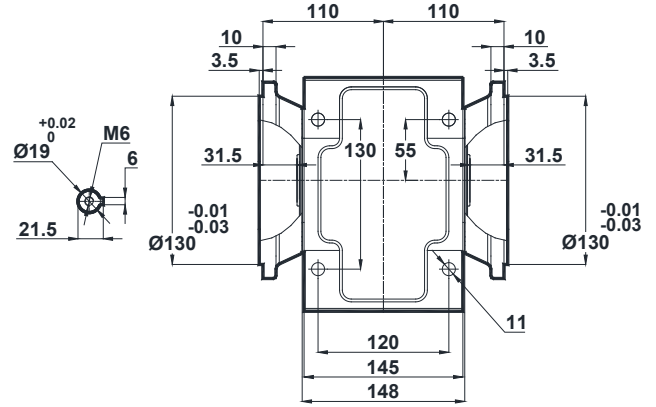
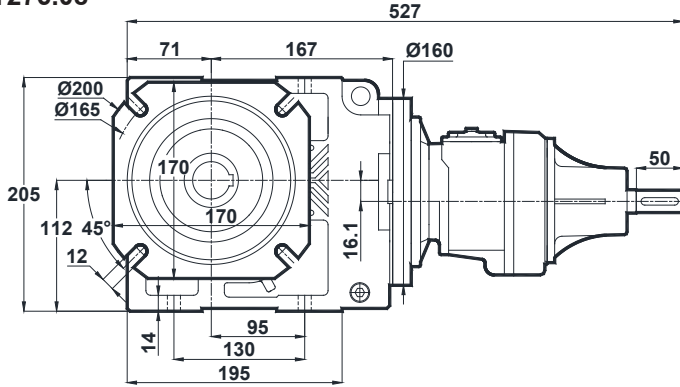



# Ölçü Sayfaları

## Dimension Pages

### Abmessungsseiten

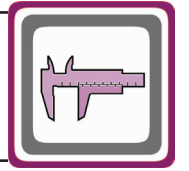

-Mil ucu çekirme deliği DIN 332 sayfa 2 / Tapped center hole to DIN 332, sheet 2 / Zentrierung mit Gewinde DIN 332, Blatt 2

#### KT373.00

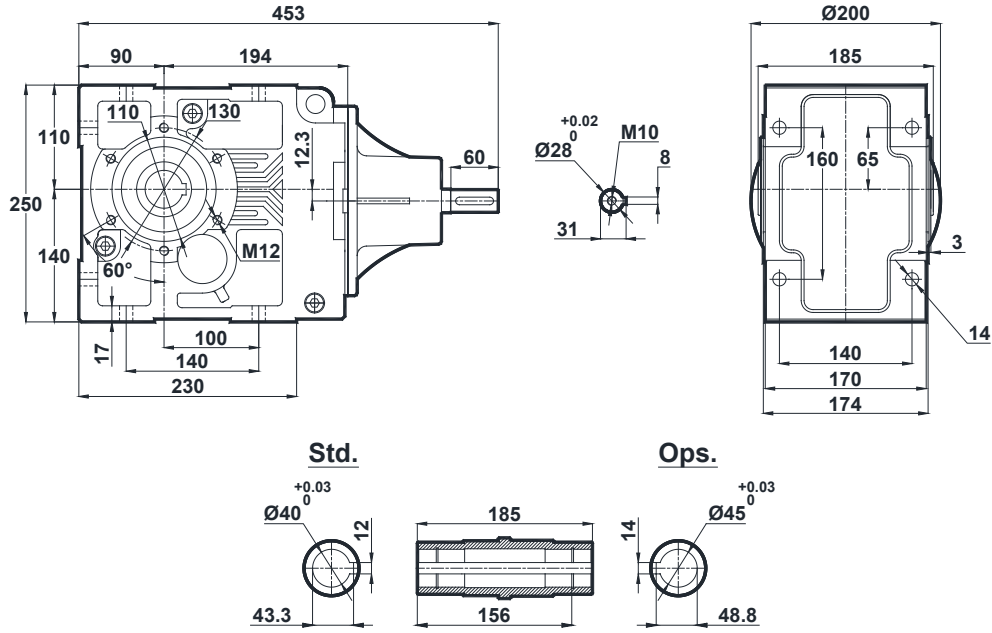

#### KT373.01

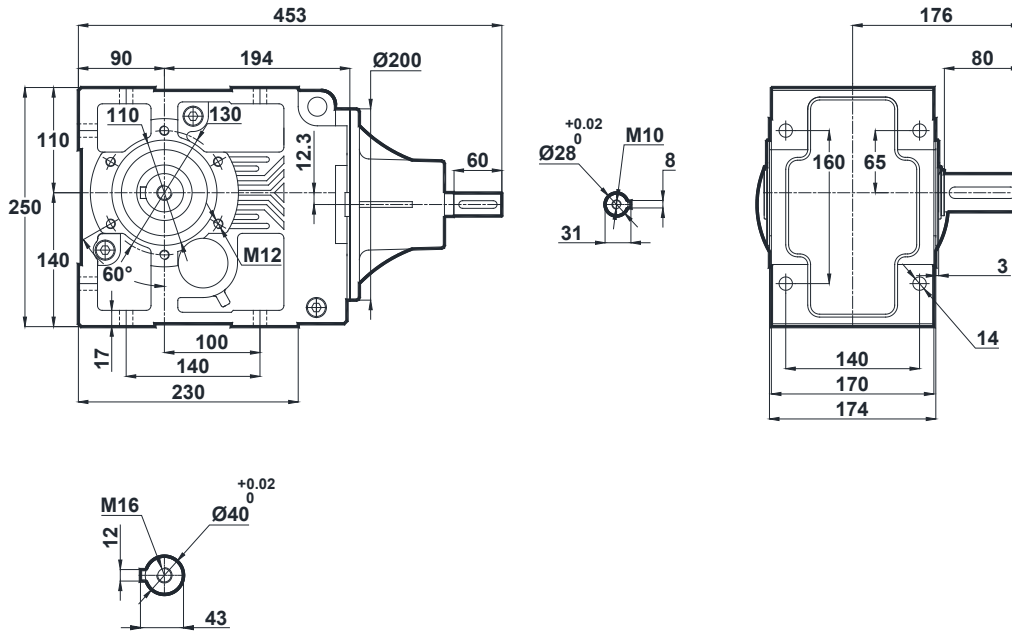



# Ölçü Sayfaları

## Dimension Pages

### Abmessungsseiten

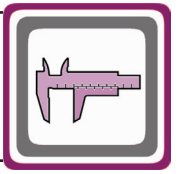

-Mil ucu çekirme deliği DIN 332 sayfa 2 / Tapped center hole to DIN 332, sheet 2 / Zentrierung mit Gewinde DIN 332, Blatt 2

#### KT373.02

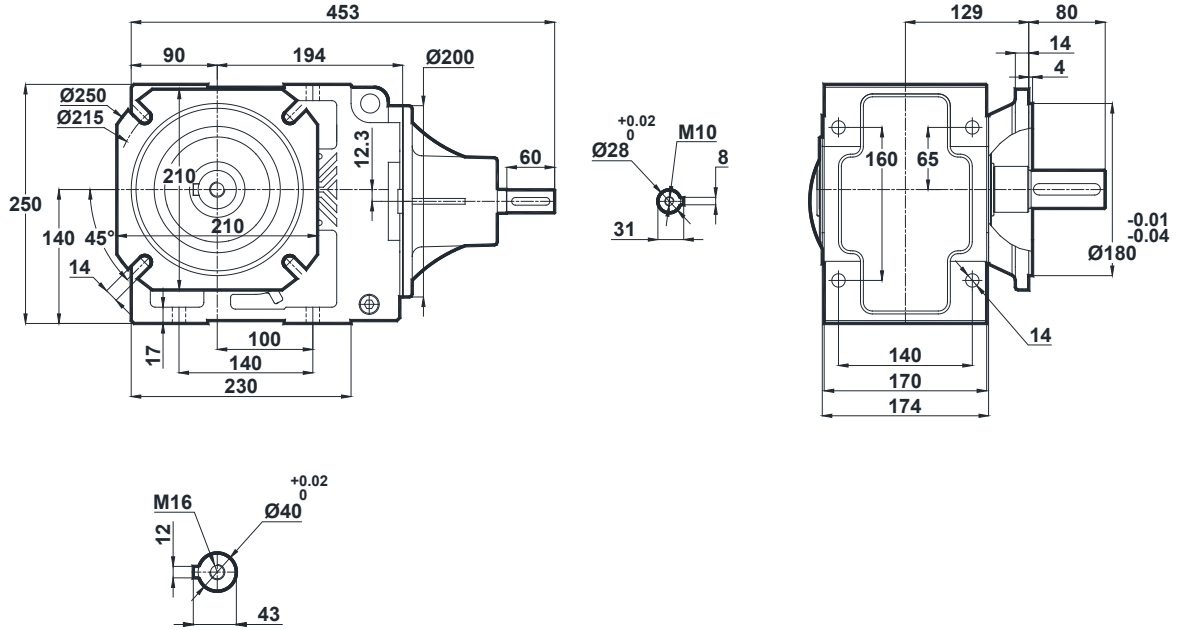

#### KT373.03

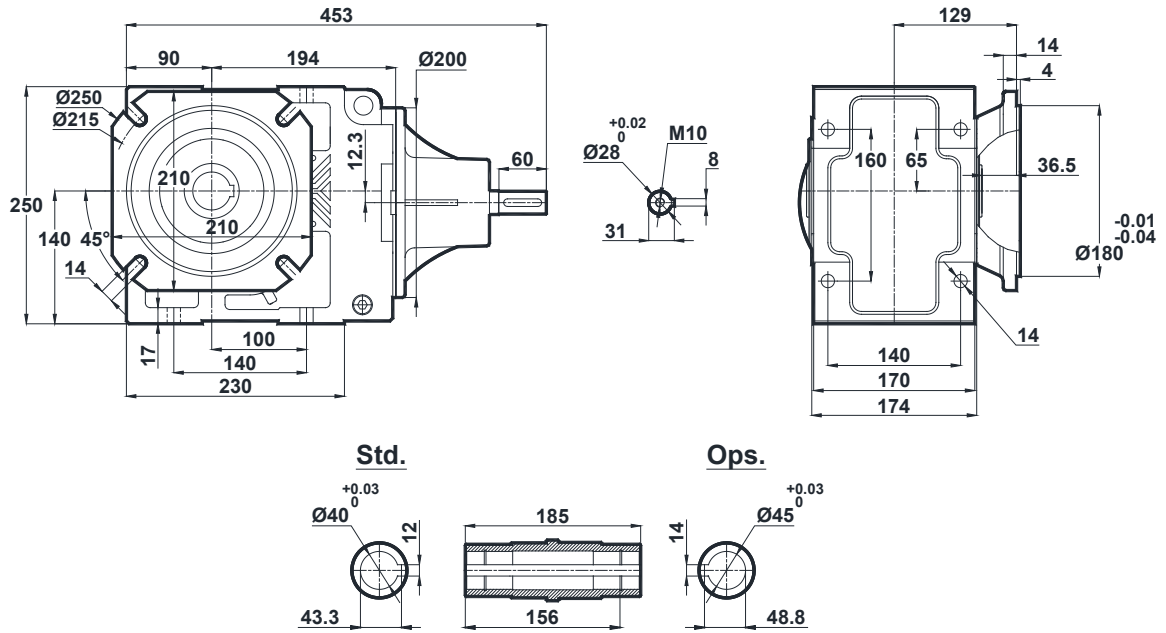

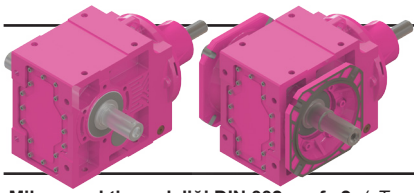

# Ölçü Sayfaları

## Dimension Pages

### Abmessungsseiten

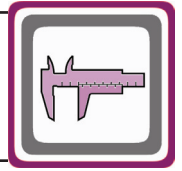

-Mil ucu çektirme deliği DIN 332 sayfa 2 / Tapped center hole to DIN 332, sheet 2 / Zentrierung mit Gewinde DIN 332, Blatt 2

#### KT373.04

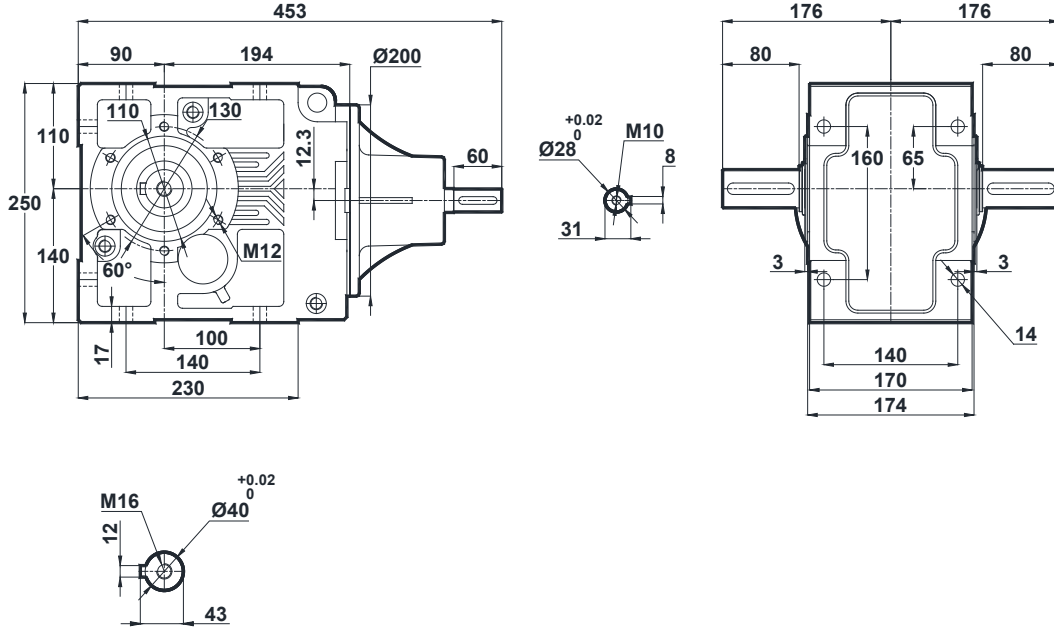

#### KT373.05

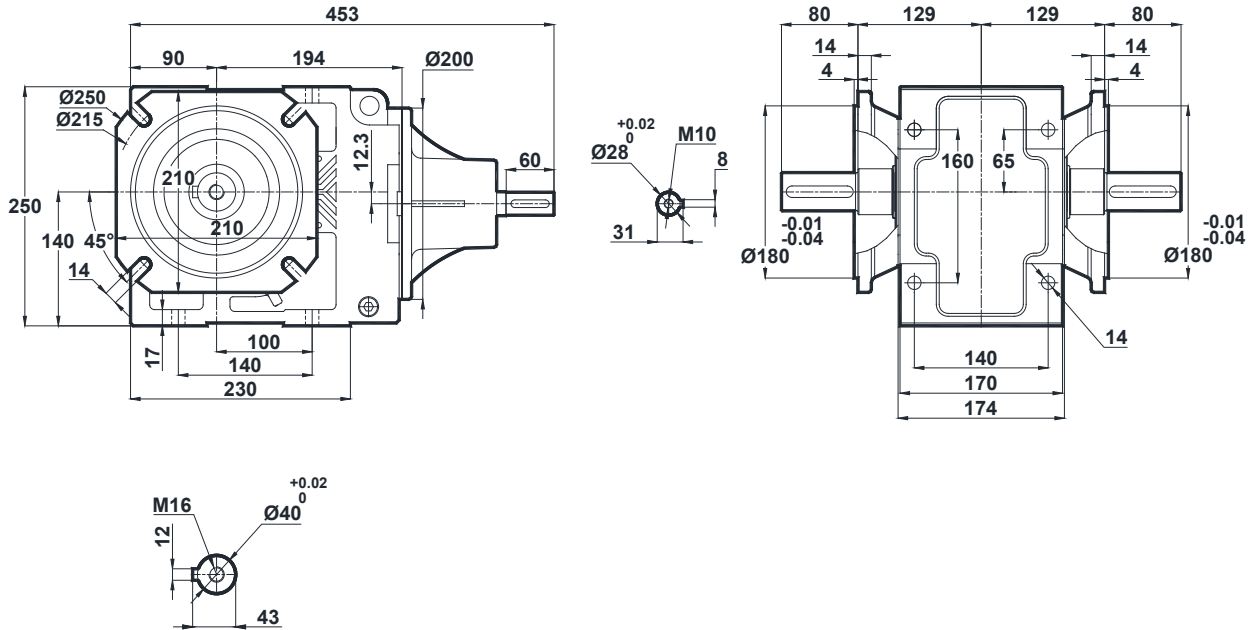



# Ölçü Sayfaları Dimension Pages Abmessungsseiten



-Mil ucu çekirme deliği DIN 332 sayfa 2 / Tapped center hole to DIN 332, sheet 2 / Zentrierung mit Gewinde DIN 332, Blatt 2

KT373.08

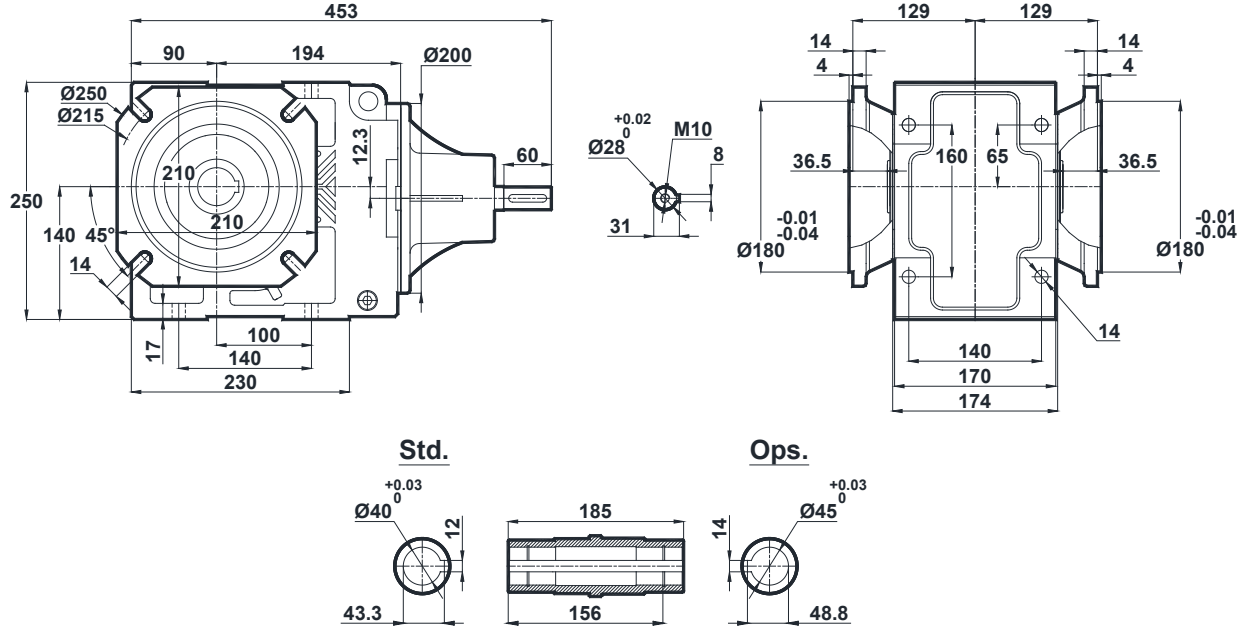



# Ölçü Sayfaları

## Dimension Pages

### Abmessungsseiten

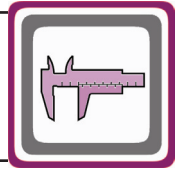

-Mil ucu çekirme deliği DIN 332 sayfa 2 / Tapped center hole to DIN 332, sheet 2 / Zentrierung mit Gewinde DIN 332, Blatt 2

#### KT374.00

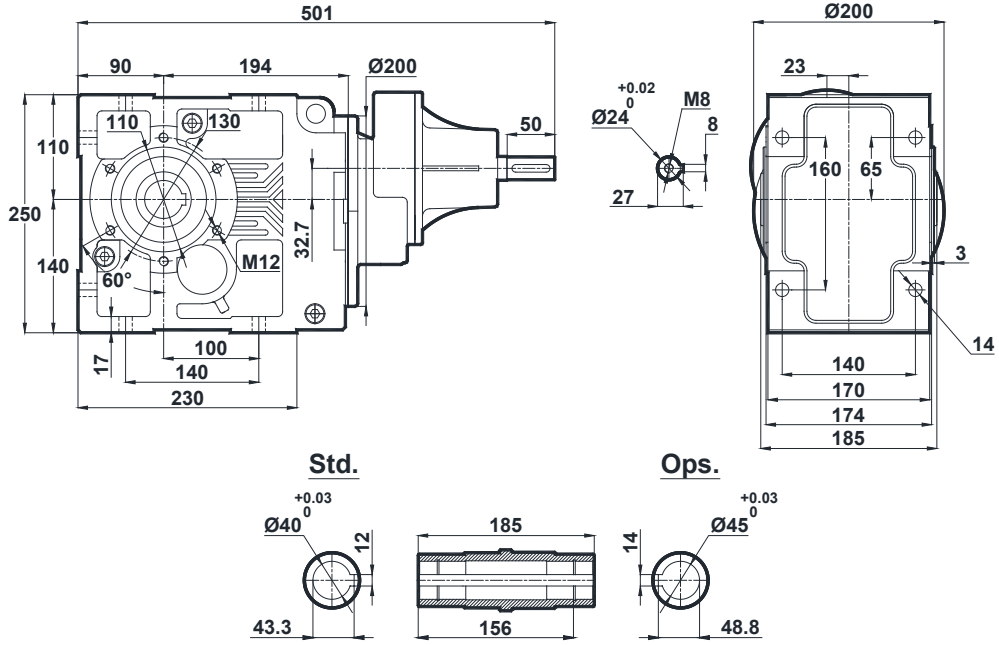

#### KT374.01

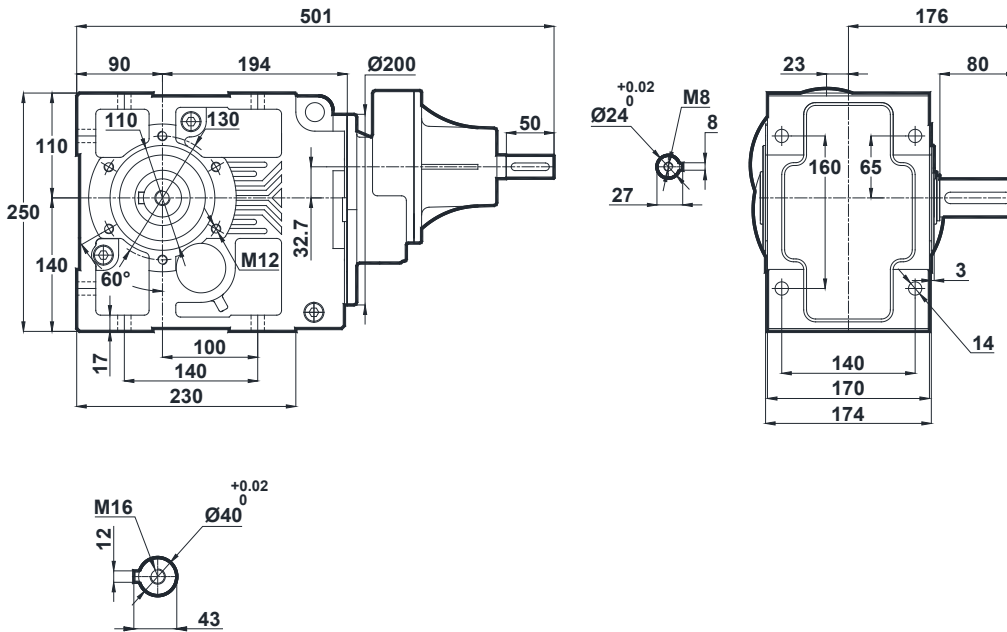



# Ölçü Sayfaları

## Dimension Pages

### Abmessungsseiten



-Mil ucu çektirme deliği DIN 332 sayfa 2 / Tapped center hole to DIN 332, sheet 2 / Zentrierung mit Gewinde DIN 332, Blatt 2

#### KT374.02

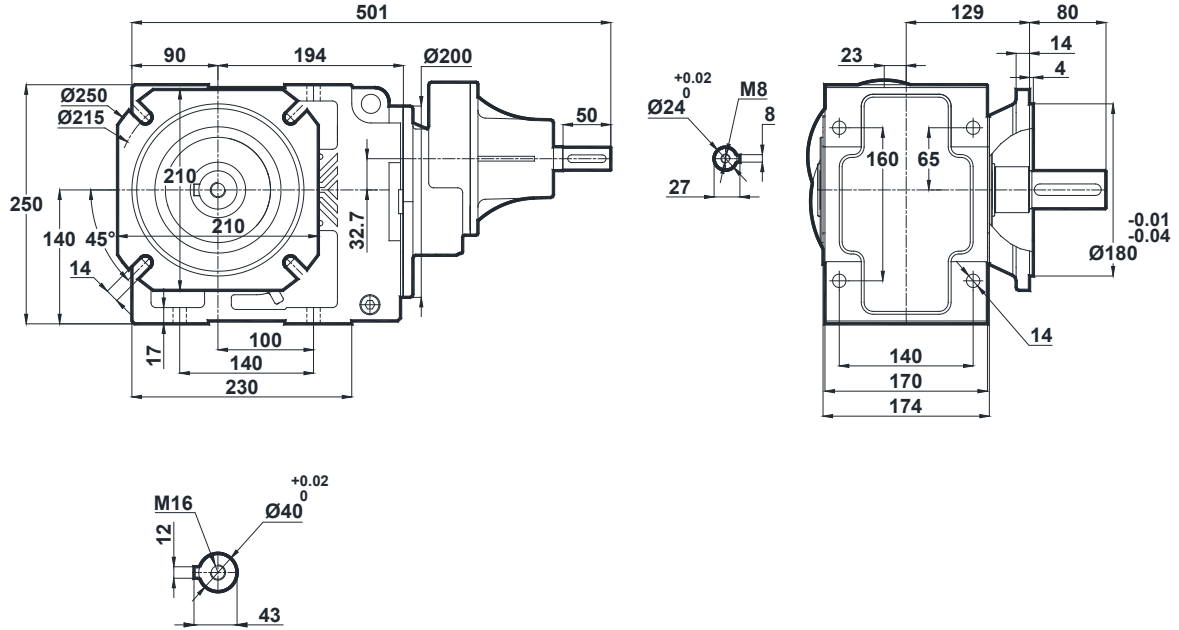

#### KT374.03

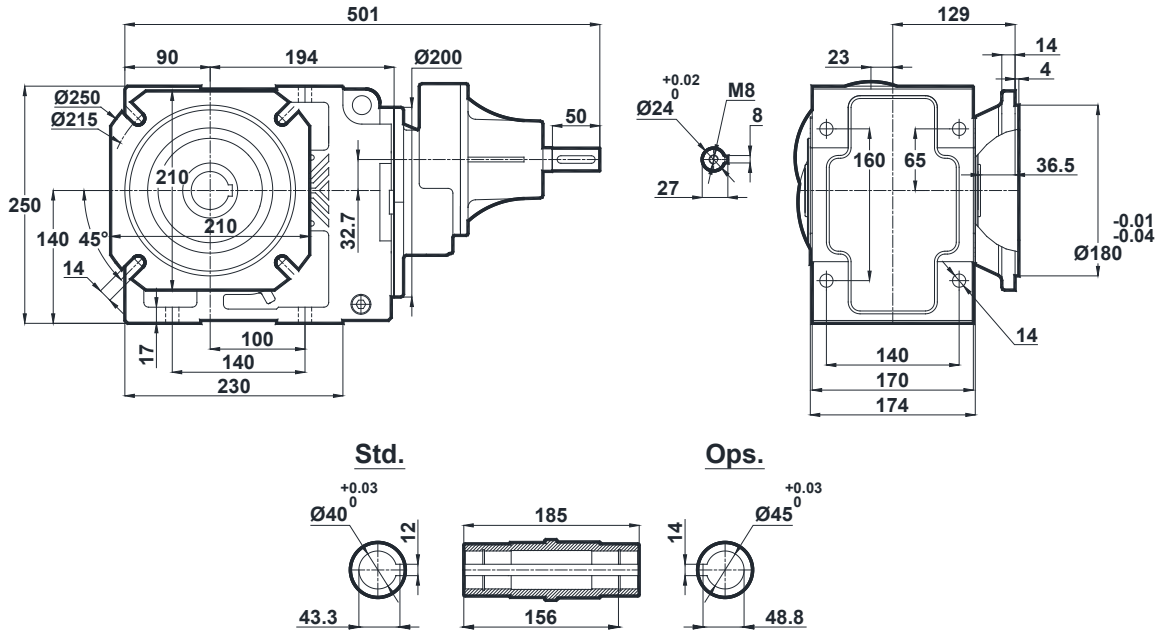

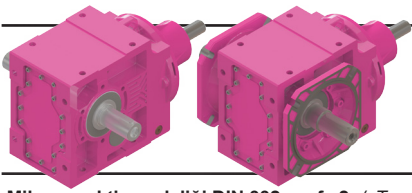

# Ölçü Sayfaları

## Dimension Pages

### Abmessungsseiten

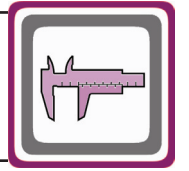

-Mil ucu çekirme deliği DIN 332 sayfa 2 / Tapped center hole to DIN 332, sheet 2 / Zentrierung mit Gewinde DIN 332, Blatt 2

#### KT374.04

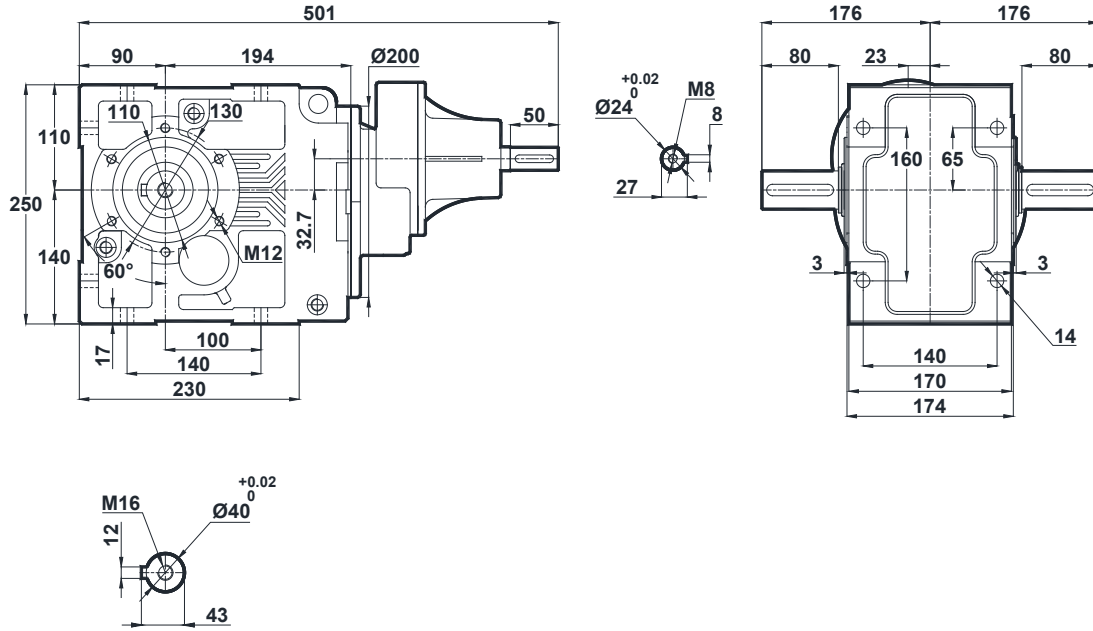

#### KT374.05

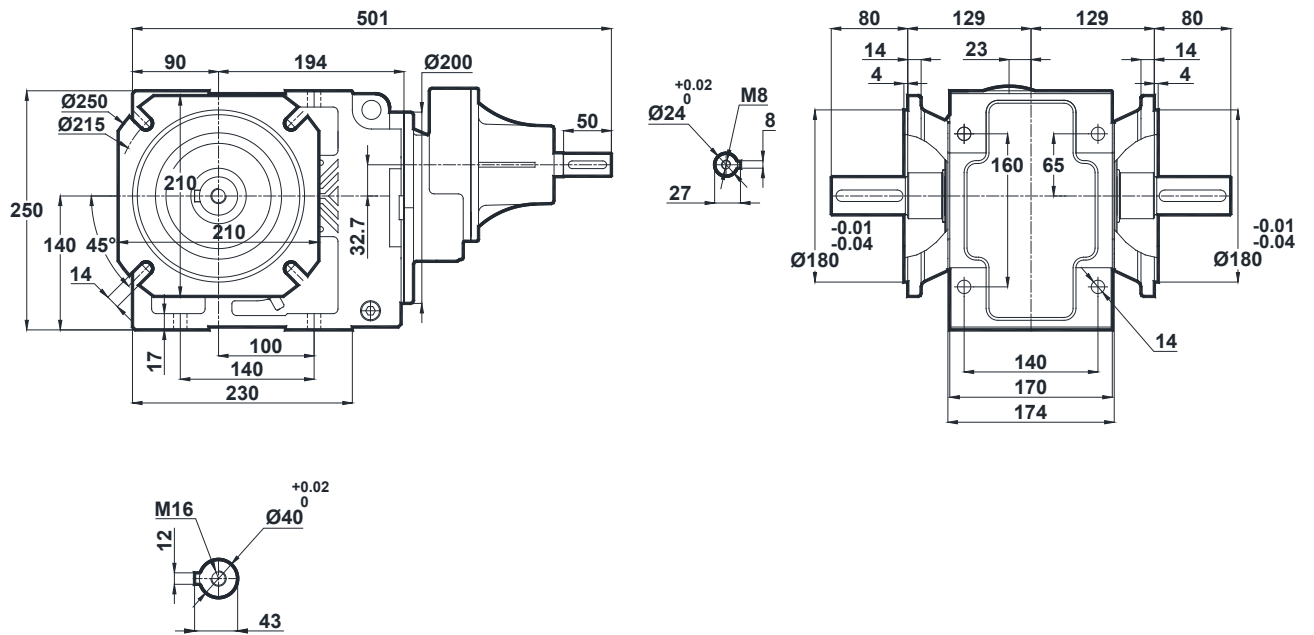





# Ölçü Sayfaları

## Dimension Pages

### Abmessungenseiten



-Mil ucu çektirme deliği DIN 332 sayfa 2 / Tapped center hole to DIN 332, sheet 2 / Zentrierung mit Gewinde DIN 332, Blatt 2

KT374.08

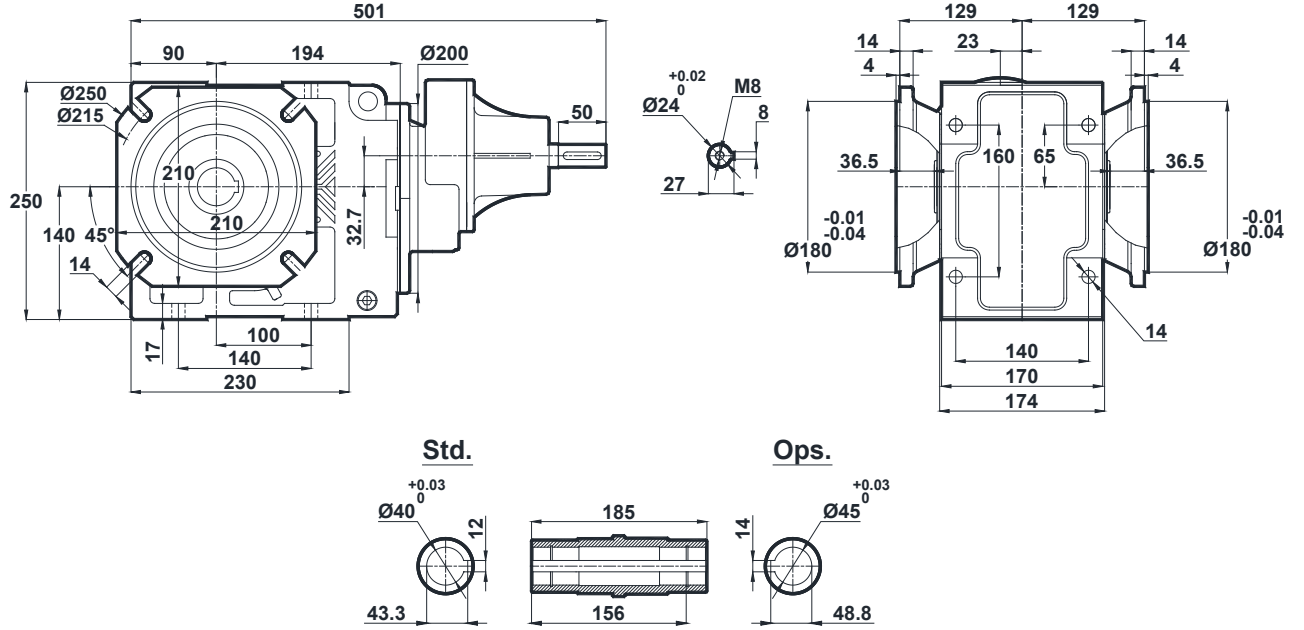



# Ölçü Sayfaları

## Dimension Pages

### Abmessungsseiten

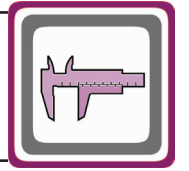

-Mil ucu çekirme deliği DIN 332 sayfa 2 / Tapped center hole to DIN 332, sheet 2 / Zentrierung mit Gewinde DIN 332, Blatt 2

KT375.00  
KT376.00

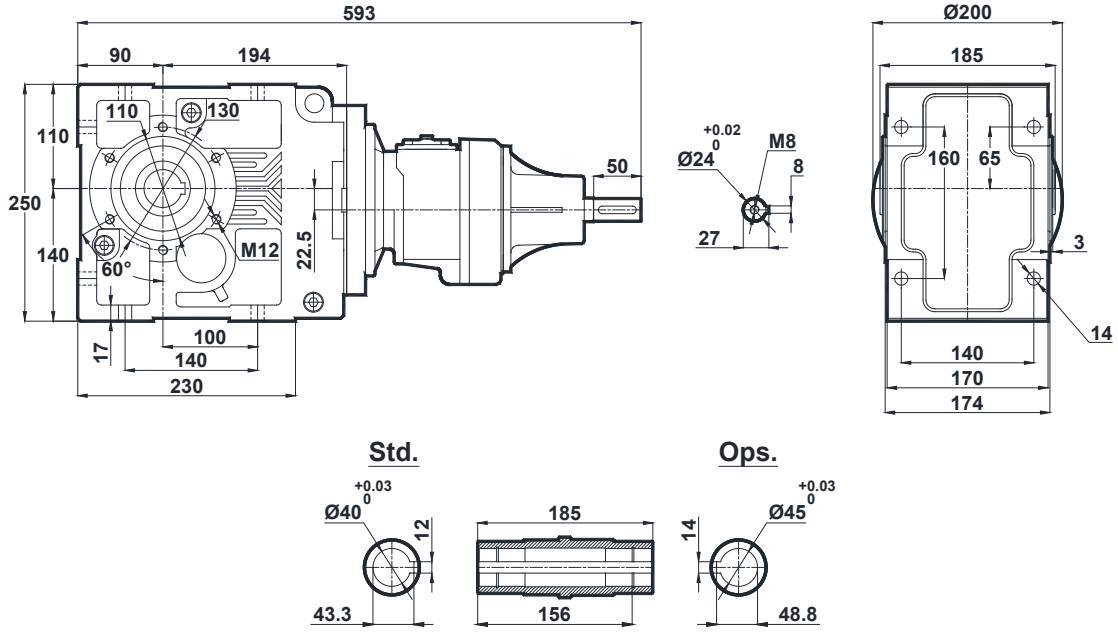

KT375.01  
KT376.01

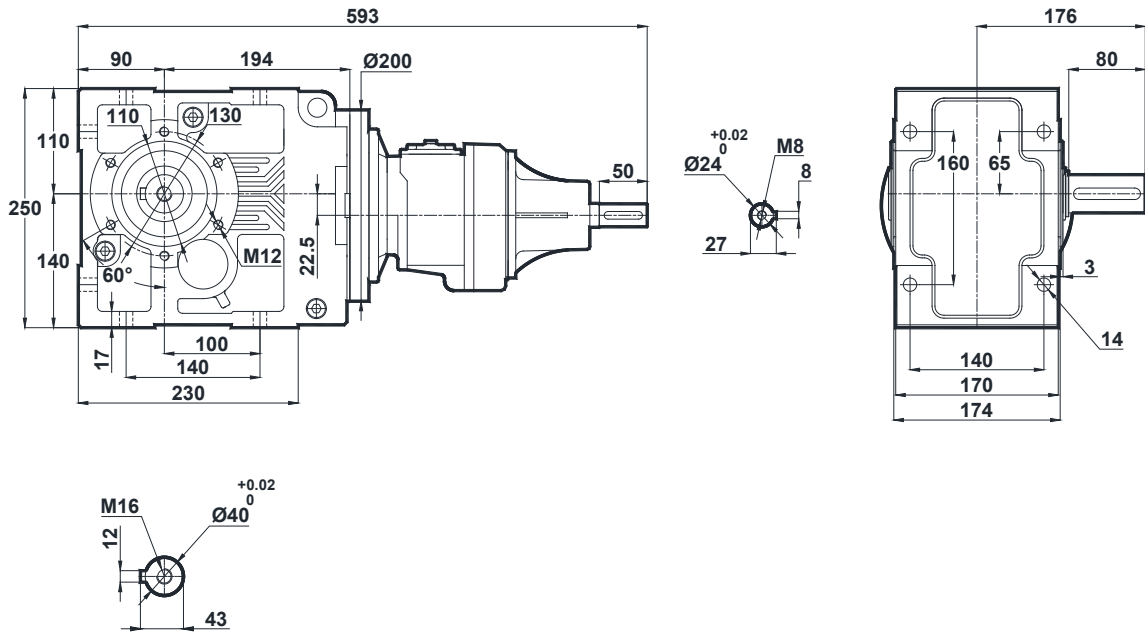

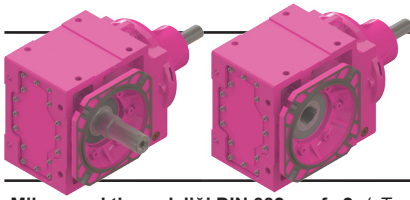

# Ölçü Sayfaları

## Dimension Pages

### Abmessungsseiten



-Mil ucu çekirme deliği DIN 332 sayfa 2 / Tapped center hole to DIN 332, sheet 2 / Zentrierung mit Gewinde DIN 332, Blatt 2

KT375.02  
KT376.02

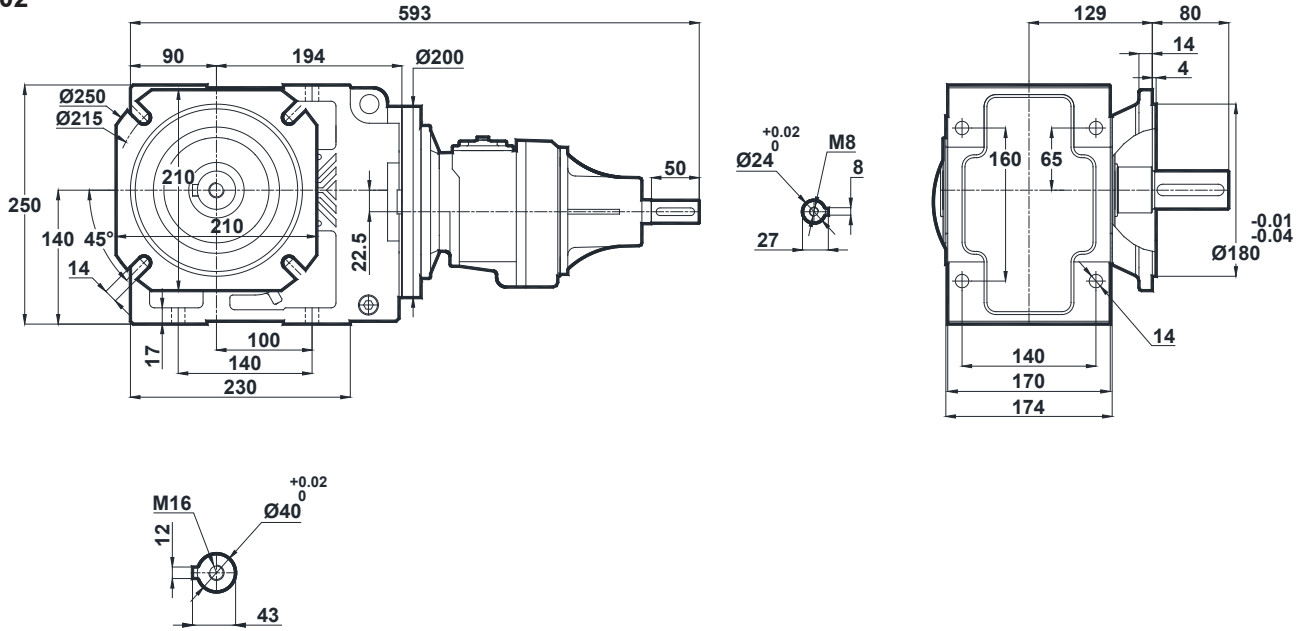

KT375.03  
KT376.03

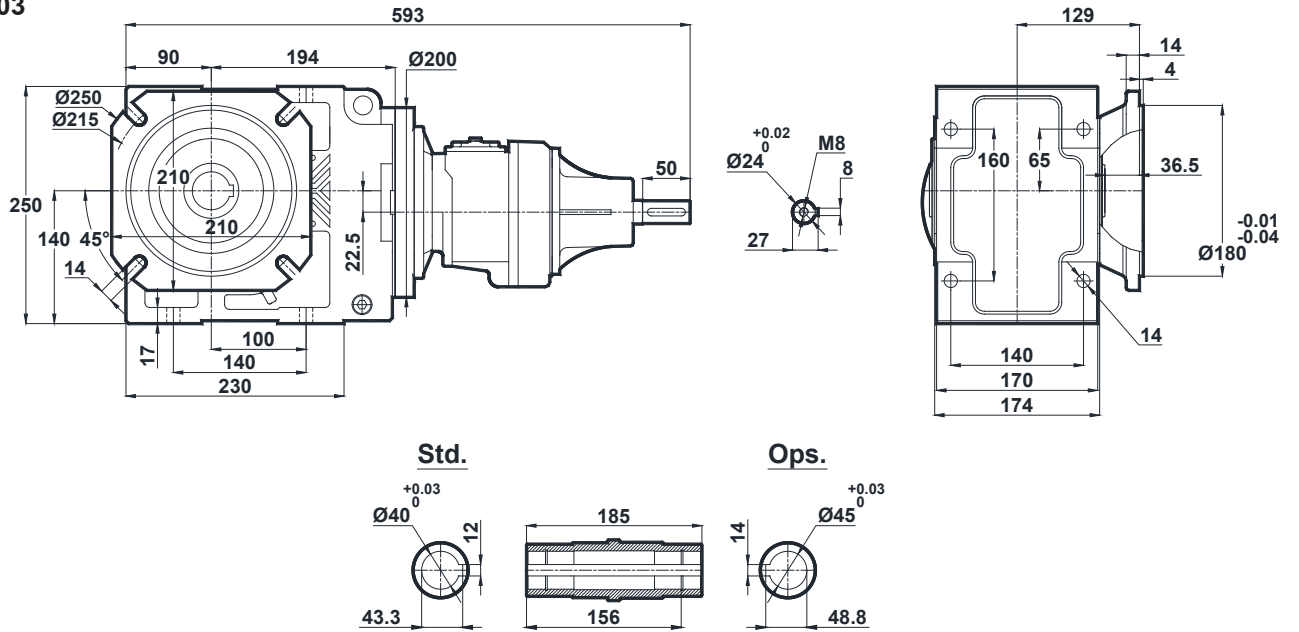

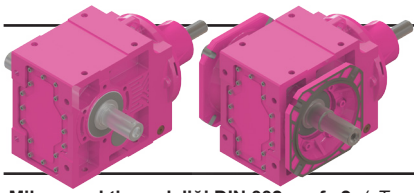

# Ölçü Sayfaları

## Dimension Pages

### Abmessungenseiten

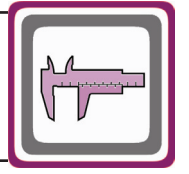

-Mil ucu çekirme deliği DIN 332 sayfa 2 / Tapped center hole to DIN 332, sheet 2 / Zentrierung mit Gewinde DIN 332, Blatt 2

KT375.04  
KT376.04

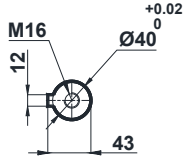
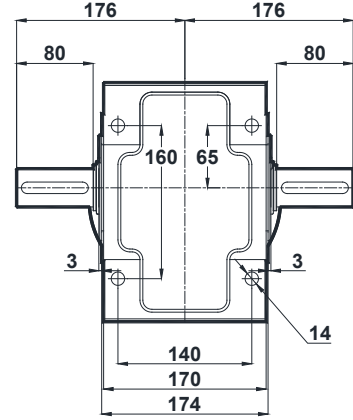
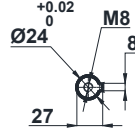
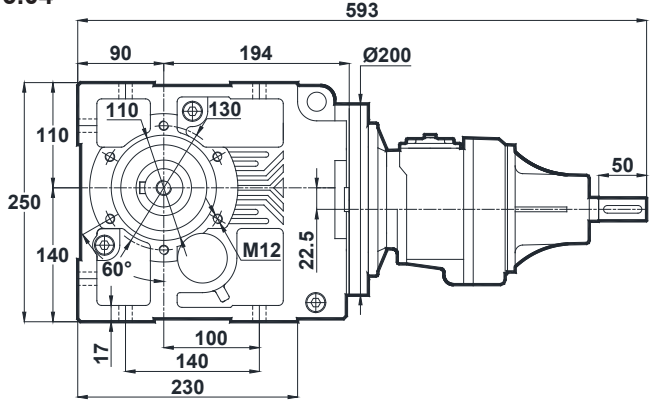

KT375.05  
KT376.05

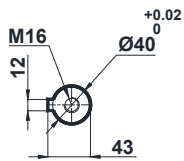
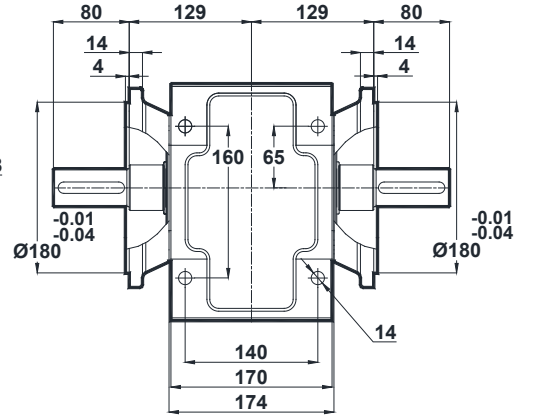
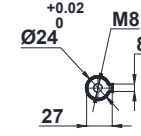
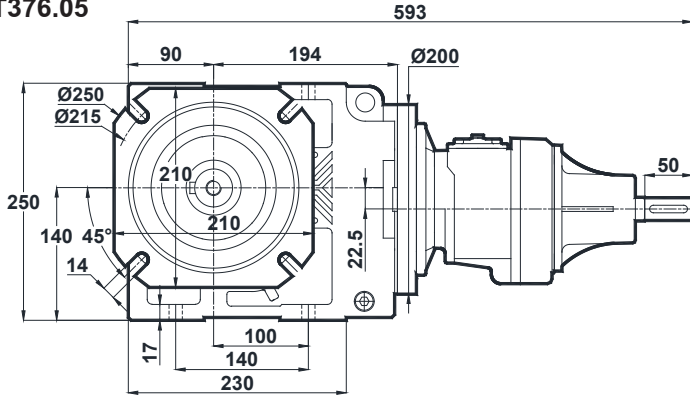



# Ölçü Sayfaları

## Dimension Pages

### Abmessungsseiten



-Mil ucu çekirme deliği DIN 332 sayfa 2 / Tapped center hole to DIN 332, sheet 2 / Zentrierung mit Gewinde DIN 332, Blatt 2

KT375.08  
KT376.08

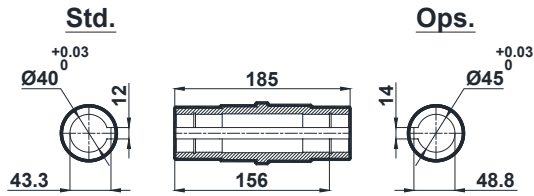
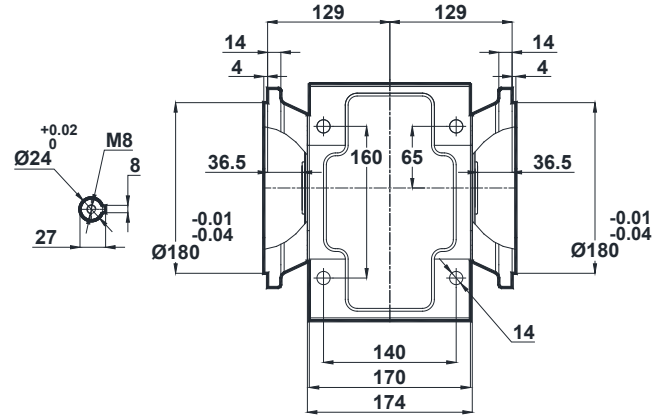
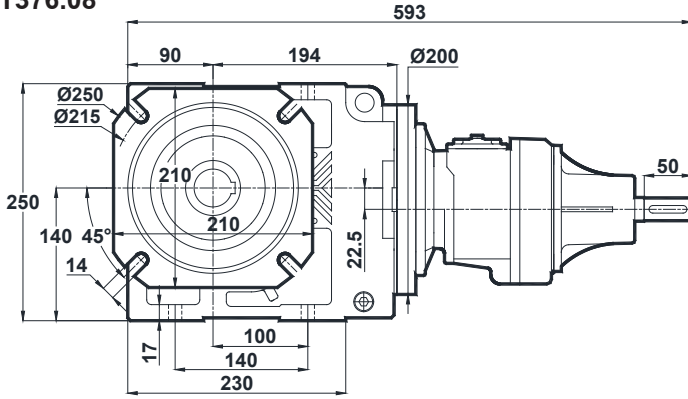



# Ölçü Sayfaları

## Dimension Pages

### Abmessungsseiten

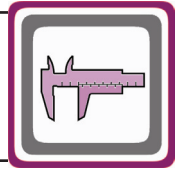

-Mil ucu çektirme deliği DIN 332 sayfa 2 / Tapped center hole to DIN 332, sheet 2 / Zentrierung mit Gewinde DIN 332, Blatt 2

#### KT473.00

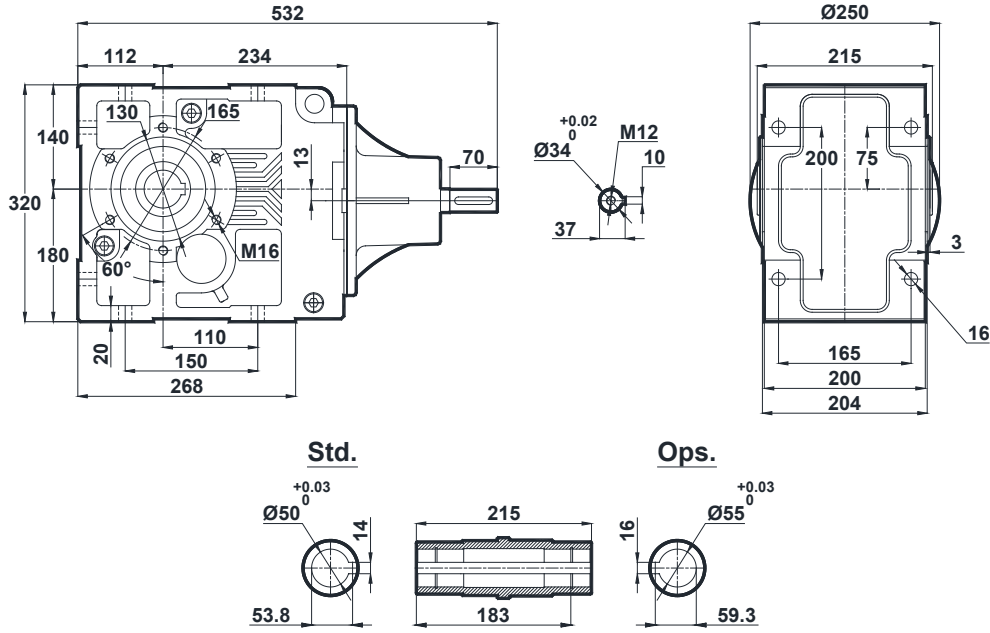

#### KT473.01

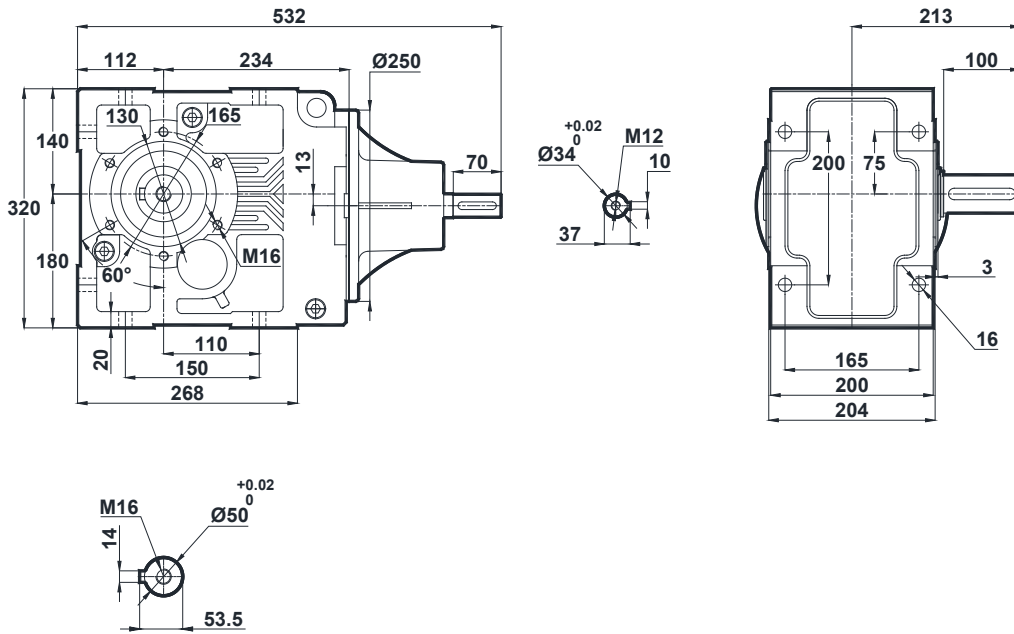



# Ölçü Sayfaları

## Dimension Pages

### Abmessungsseiten



-Mil ucu çekirme deliği DIN 332 sayfa 2 / Tapped center hole to DIN 332, sheet 2 / Zentrierung mit Gewinde DIN 332, Blatt 2

#### KT473.02

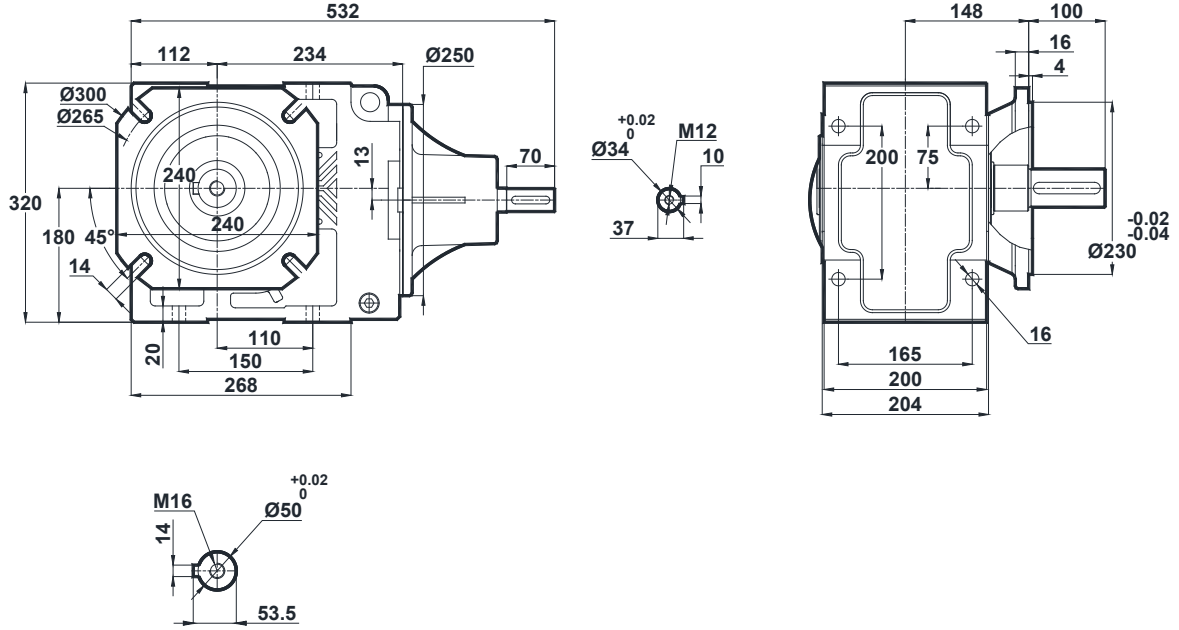

#### KT473.03

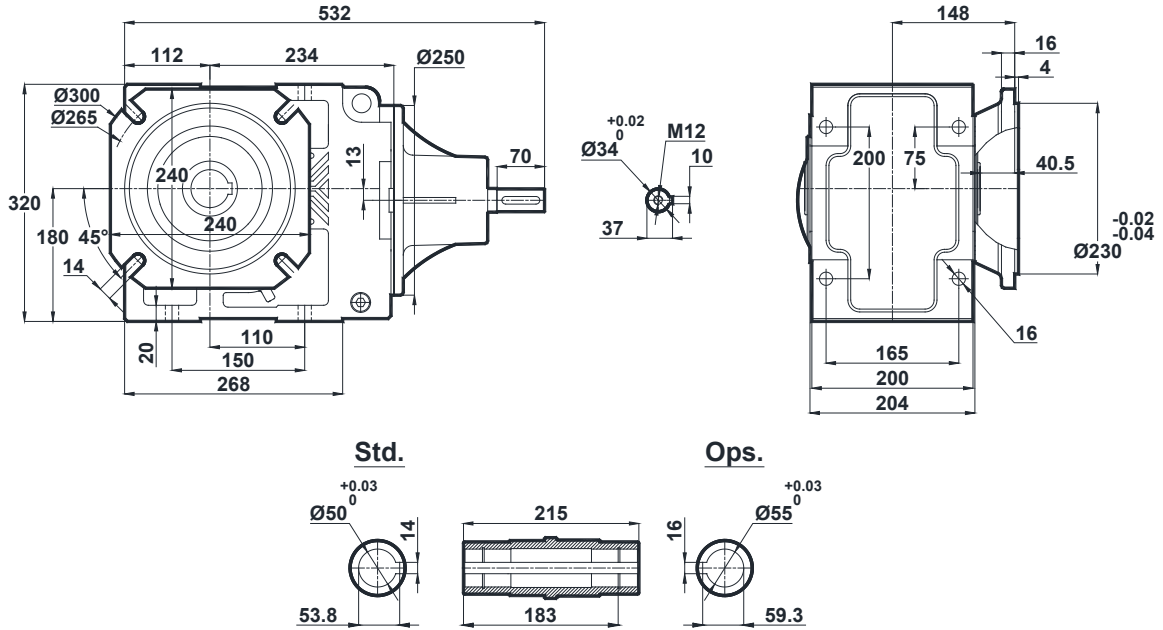

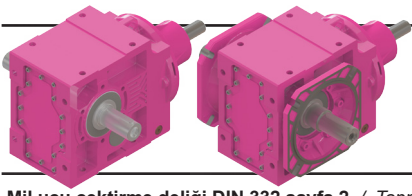

# Ölçü Sayfaları

## Dimension Pages

### Abmessungsseiten

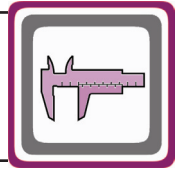

-Mil ucu çektirme deliği DIN 332 sayfa 2 / Tapped center hole to DIN 332, sheet 2 / Zentrierung mit Gewinde DIN 332, Blatt 2

#### KT473.04

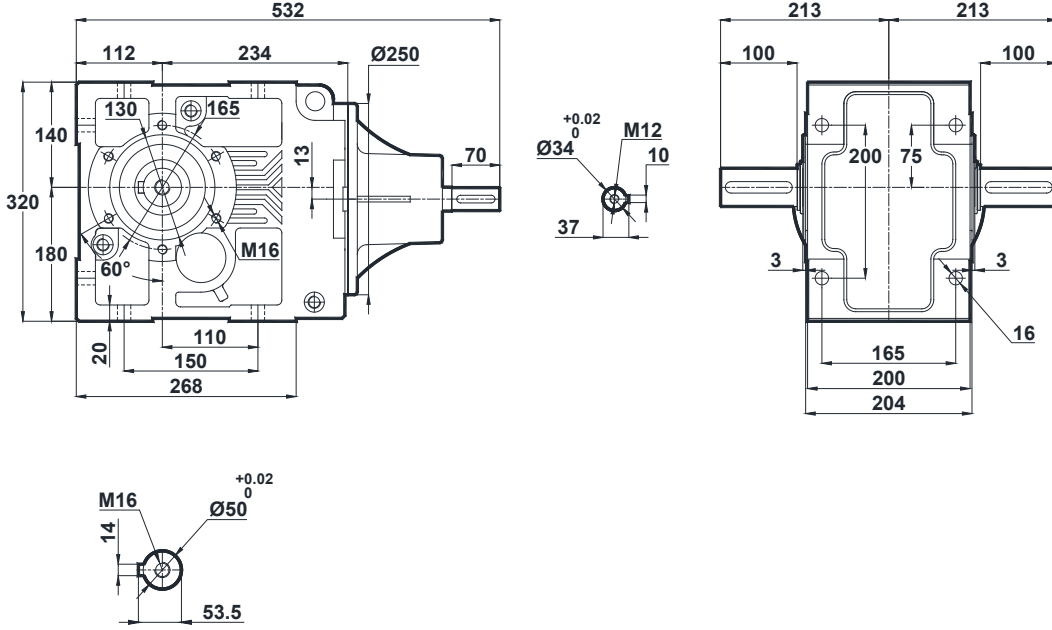

#### KT473.05

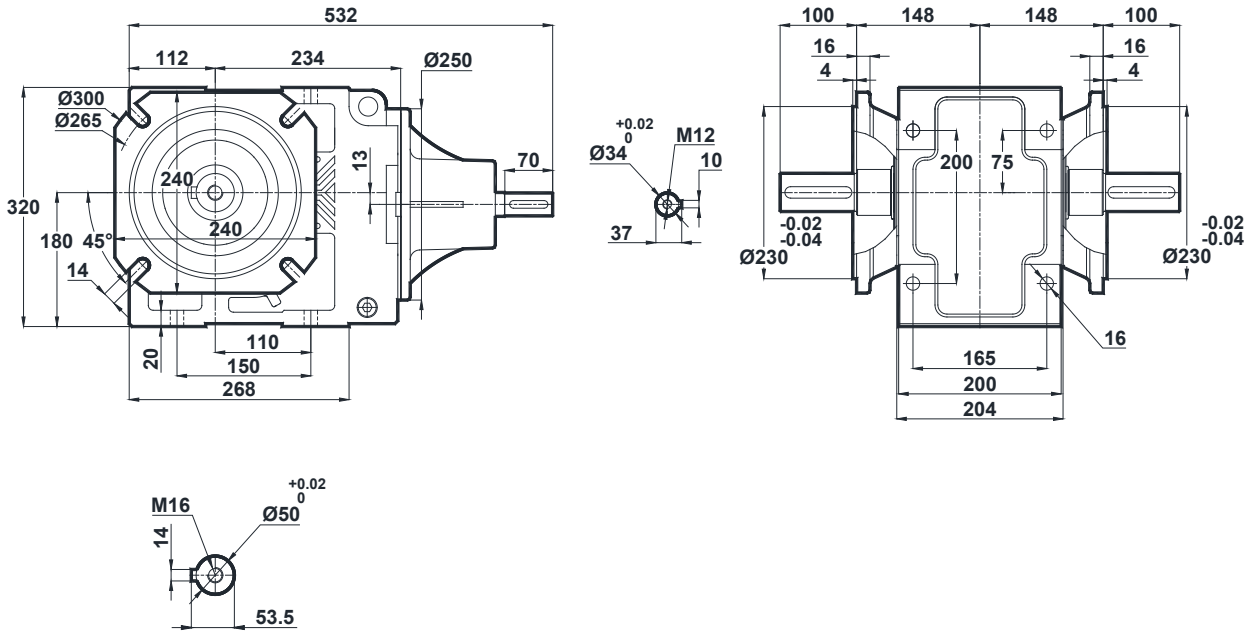





# Ölçü Sayfaları Dimension Pages Abmessungenseiten



-Mil ucu çekirme deliği DIN 332 sayfa 2 / Tapped center hole to DIN 332, sheet 2 / Zentrierung mit Gewinde DIN 332, Blatt 2

KT473.08

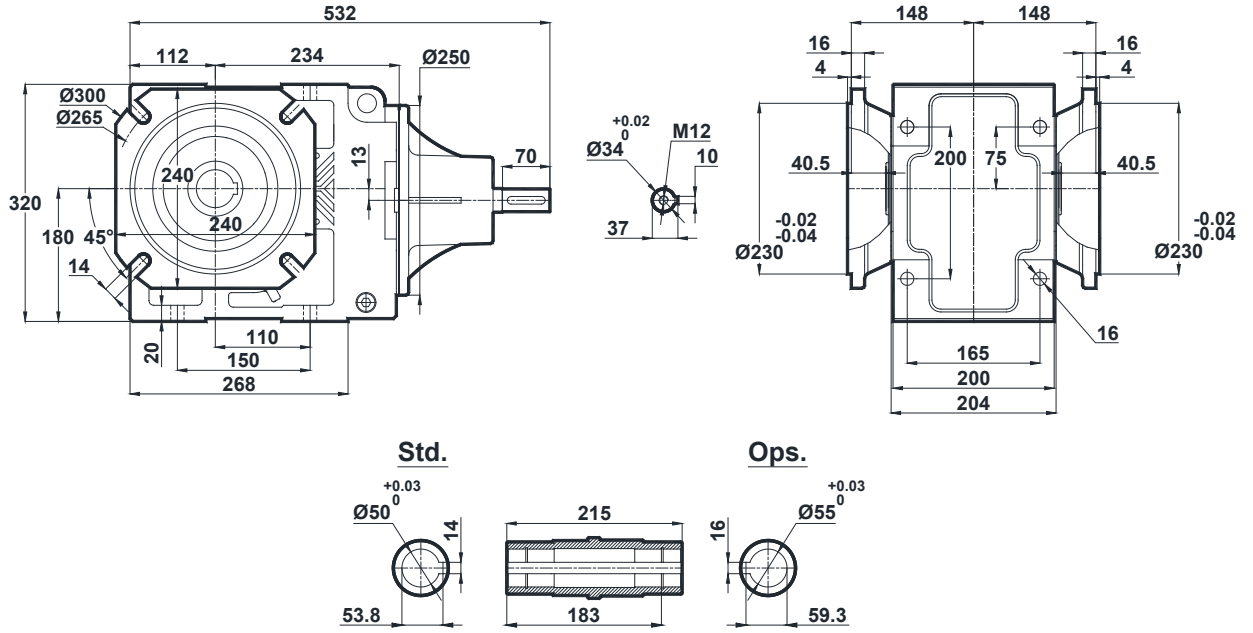



# Ölçü Sayfaları

## Dimension Pages

### Abmessungsseiten

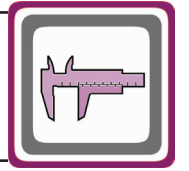

-Mil ucu çekirme deliği DIN 332 sayfa 2 / Tapped center hole to DIN 332, sheet 2 / Zentrierung mit Gewinde DIN 332, Blatt 2

#### KT474.00

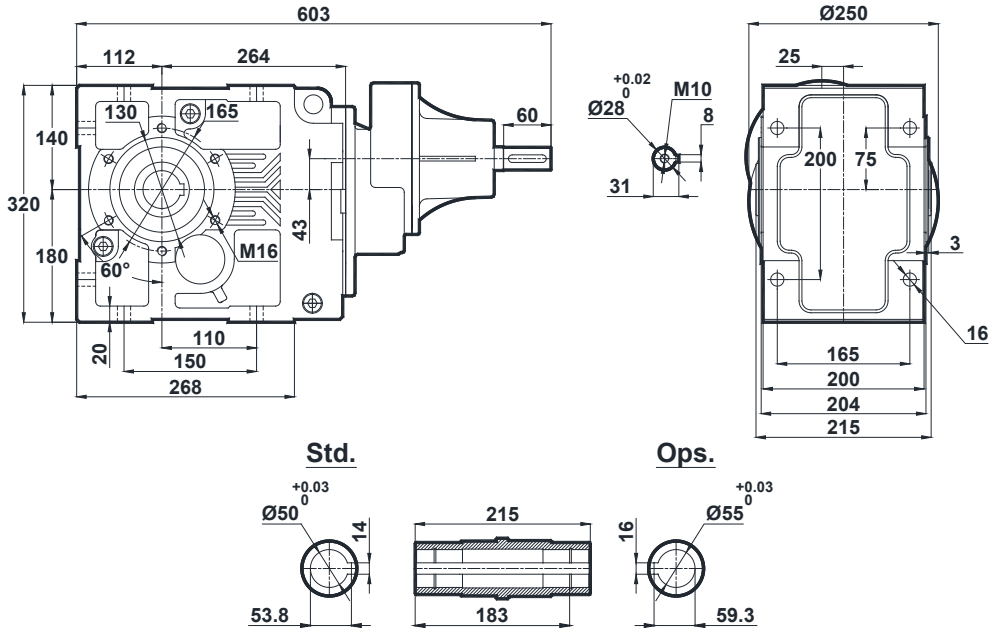

#### KT474.01

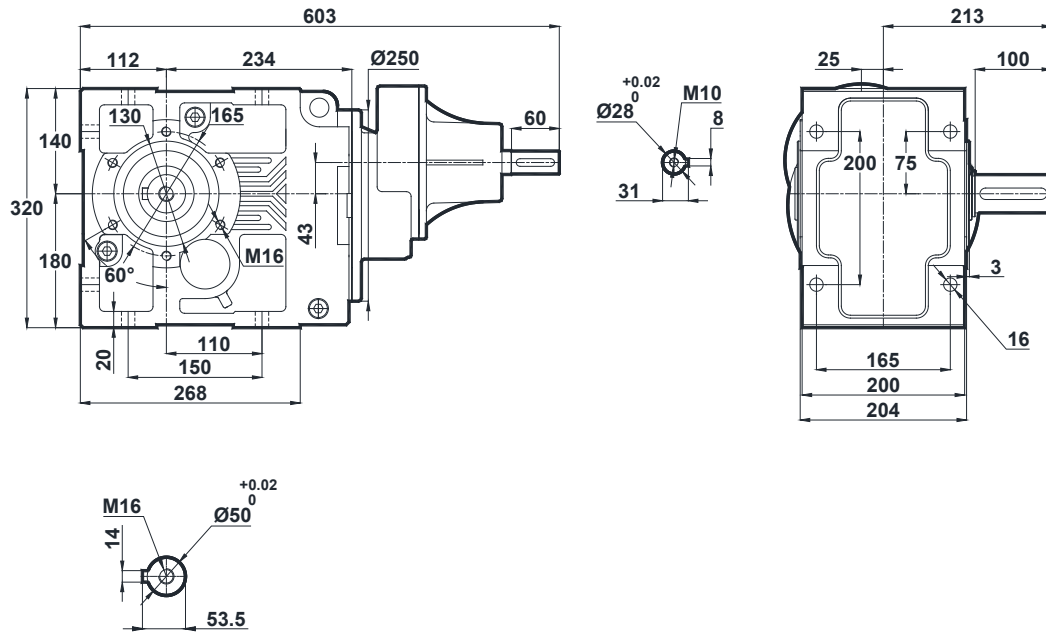



# Ölçü Sayfaları

## Dimension Pages

### Abmessungsseiten



-Mil ucu çekirme deliği DIN 332 sayfa 2 / Tapped center hole to DIN 332, sheet 2 / Zentrierung mit Gewinde DIN 332, Blatt 2

#### KT474.02

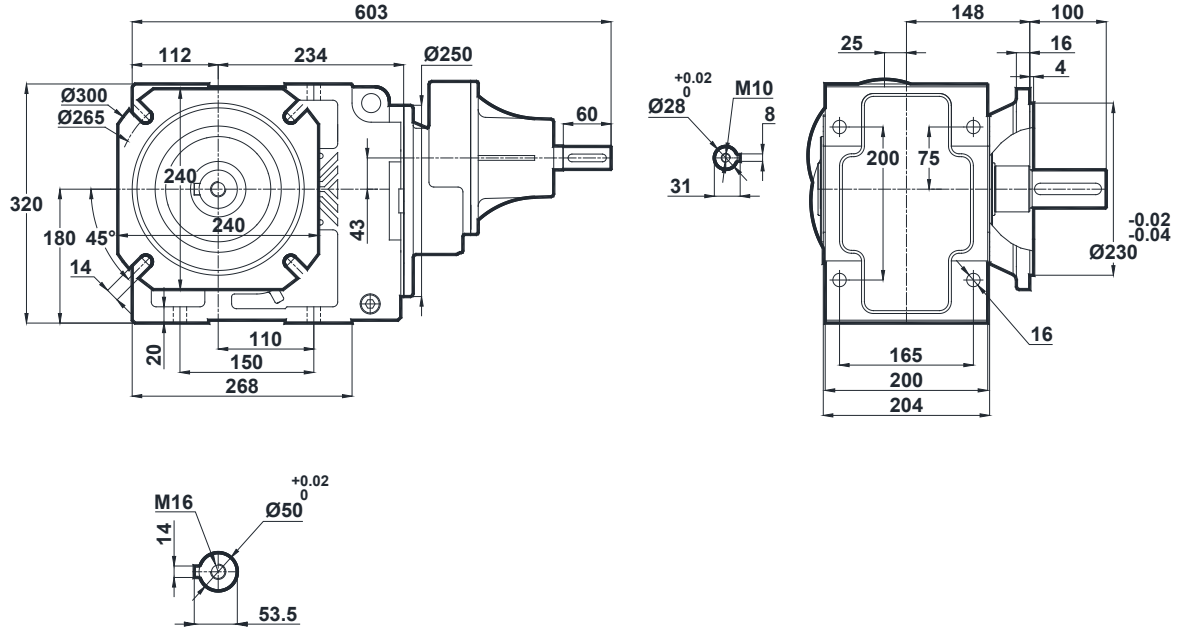

#### KT474.03

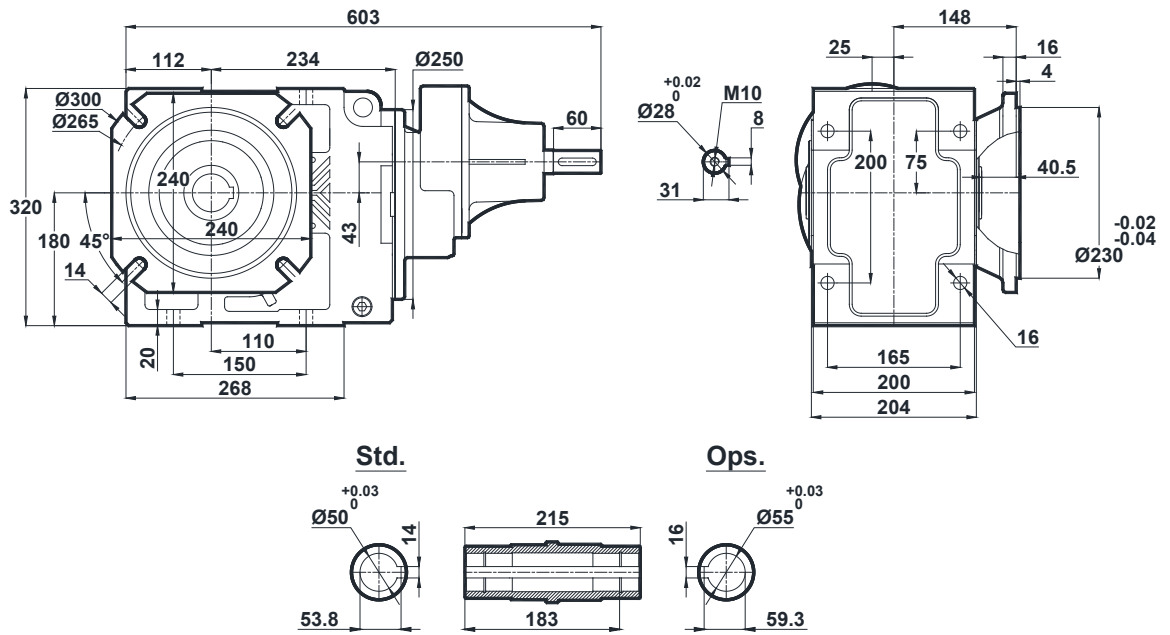

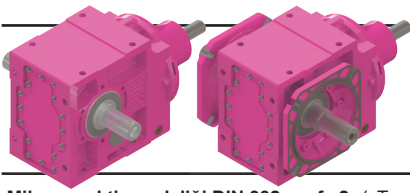

# Ölçü Sayfaları

## Dimension Pages

### Abmessungsseiten

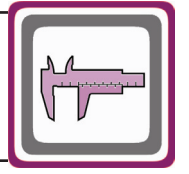

-Mil ucu çekirme deliği DIN 332 sayfa 2 / Tapped center hole to DIN 332, sheet 2 / Zentrierung mit Gewinde DIN 332, Blatt 2

#### KT474.04

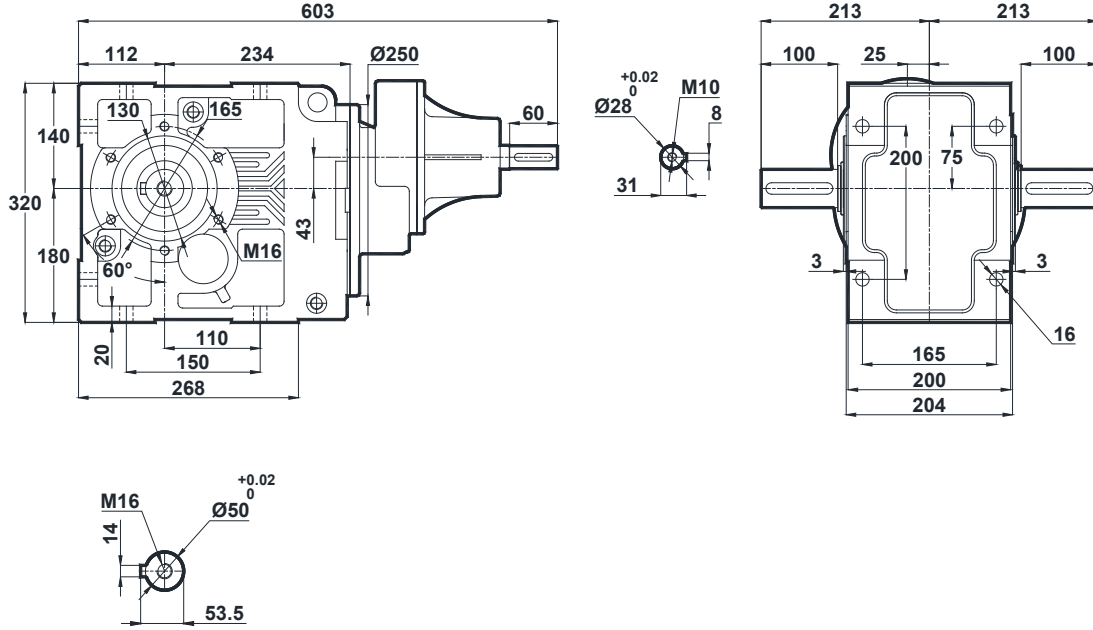

#### KT474.05

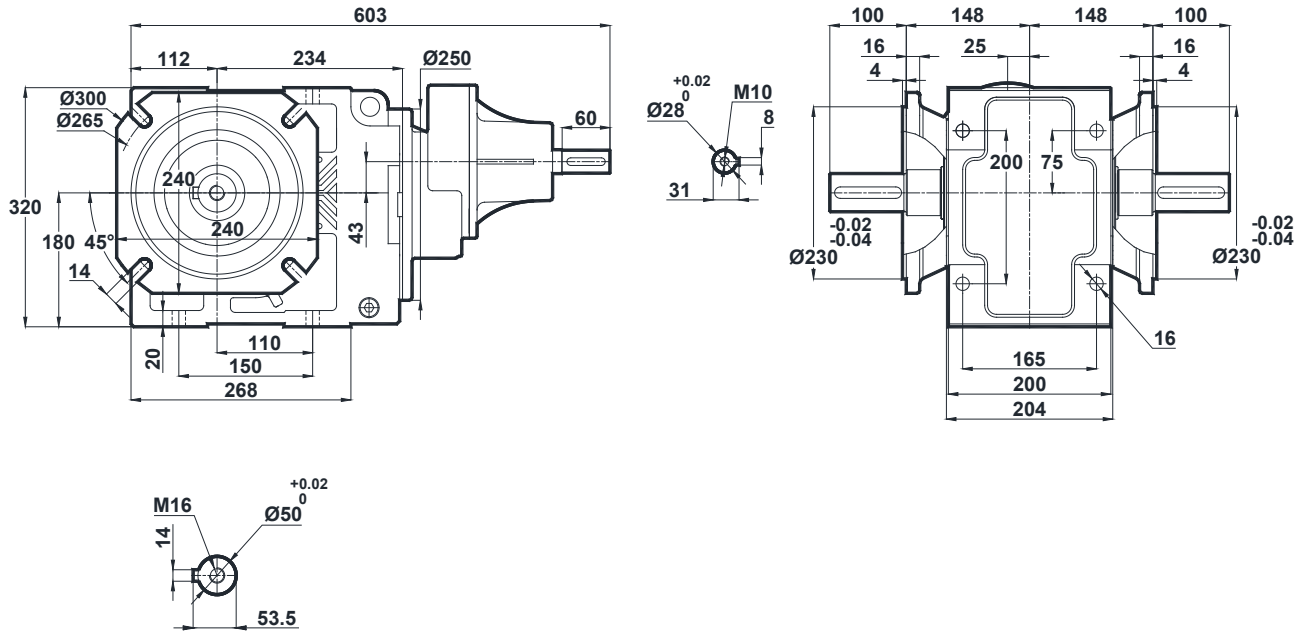



# Ölçü Sayfaları Dimension Pages Abmessungenseiten



-Mil ucu çekirme deliği DIN 332 sayfa 2 / Tapped center hole to DIN 332, sheet 2 / Zentrierung mit Gewinde DIN 332, Blatt 2

KT474.08

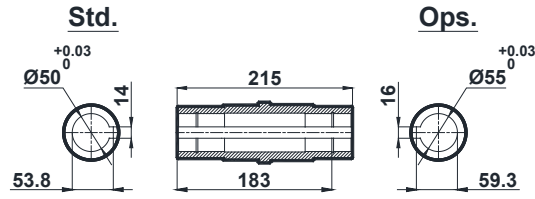
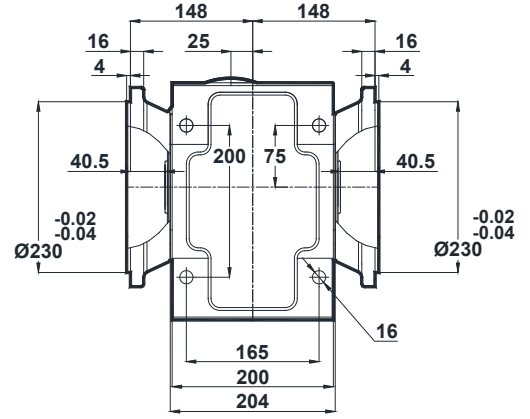
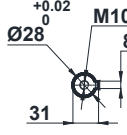
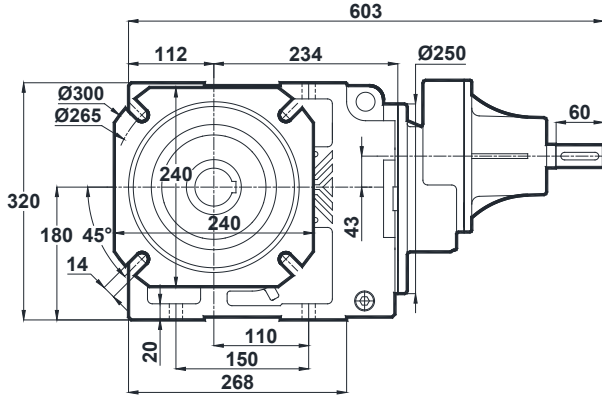



# Ölçü Sayfaları

## Dimension Pages

### Abmessungsseiten

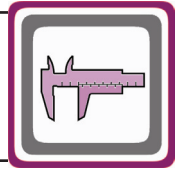

-Mil ucu çektirme deliği DIN 332 sayfa 2 / Tapped center hole to DIN 332, sheet 2 / Zentrierung mit Gewinde DIN 332, Blatt 2

KT475.00  
KT476.00

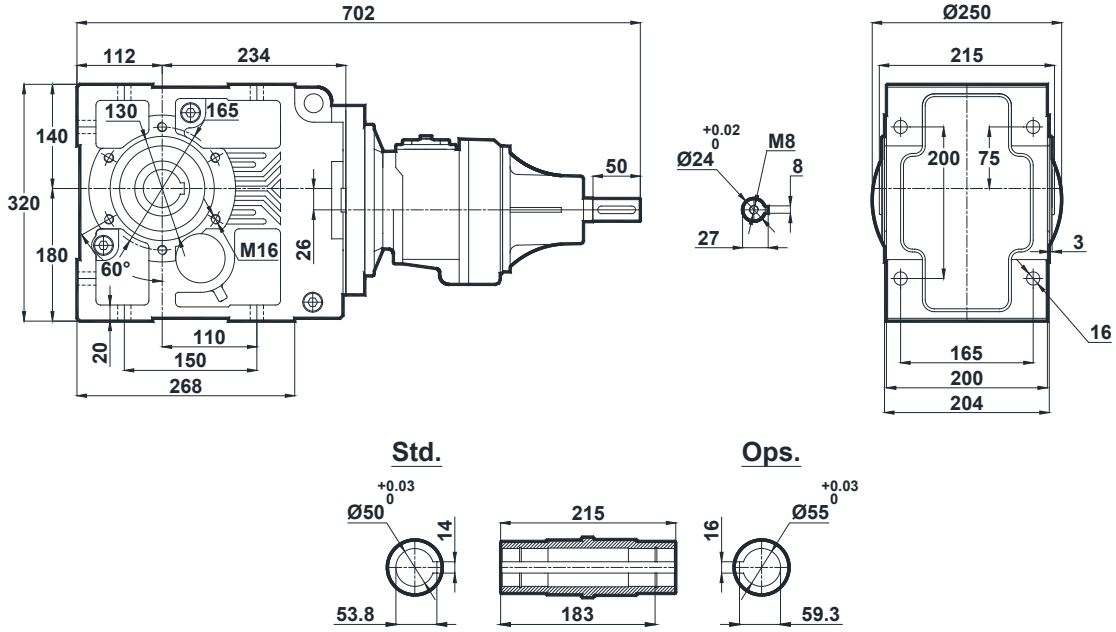

KT475.01  
KT476.01

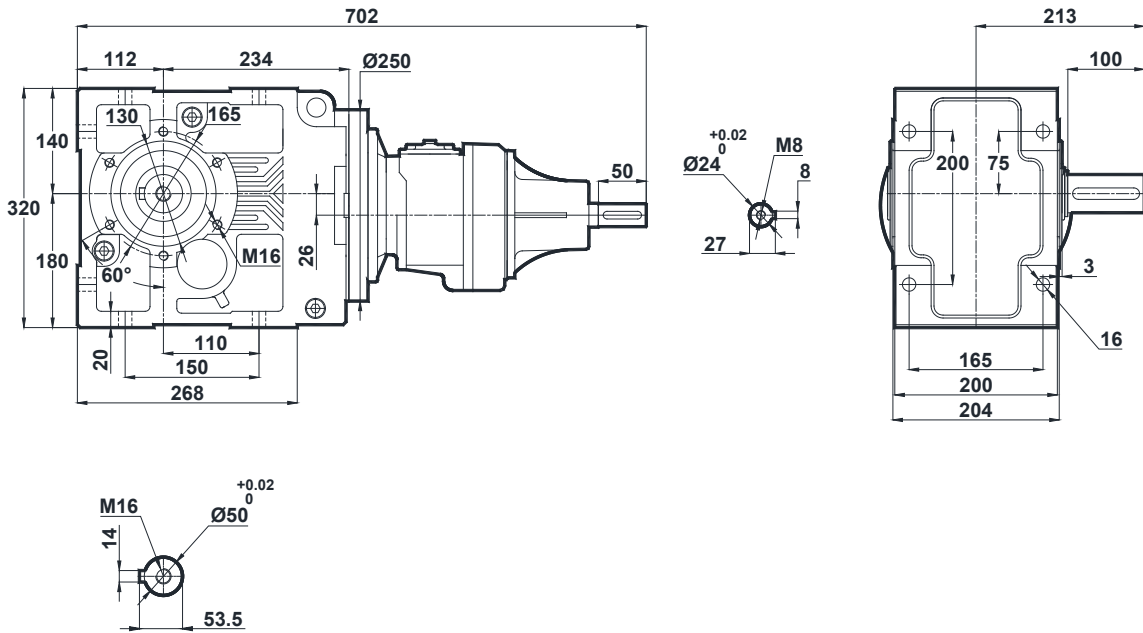



# Ölçü Sayfaları

## Dimension Pages

### Abmessungsseiten



-Mil ucu çektirme deliği DIN 332 sayfa 2 / Tapped center hole to DIN 332, sheet 2 / Zentrierung mit Gewinde DIN 332, Blatt 2

KT475.02  
KT476.02

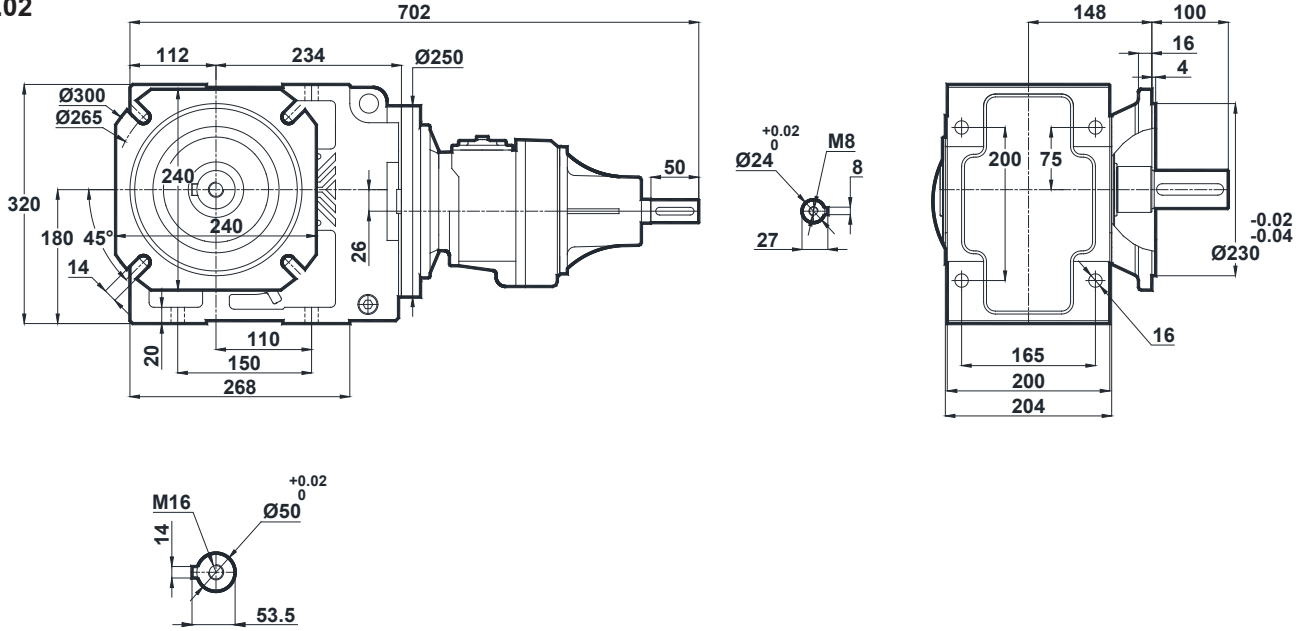

KT475.03  
KT476.03

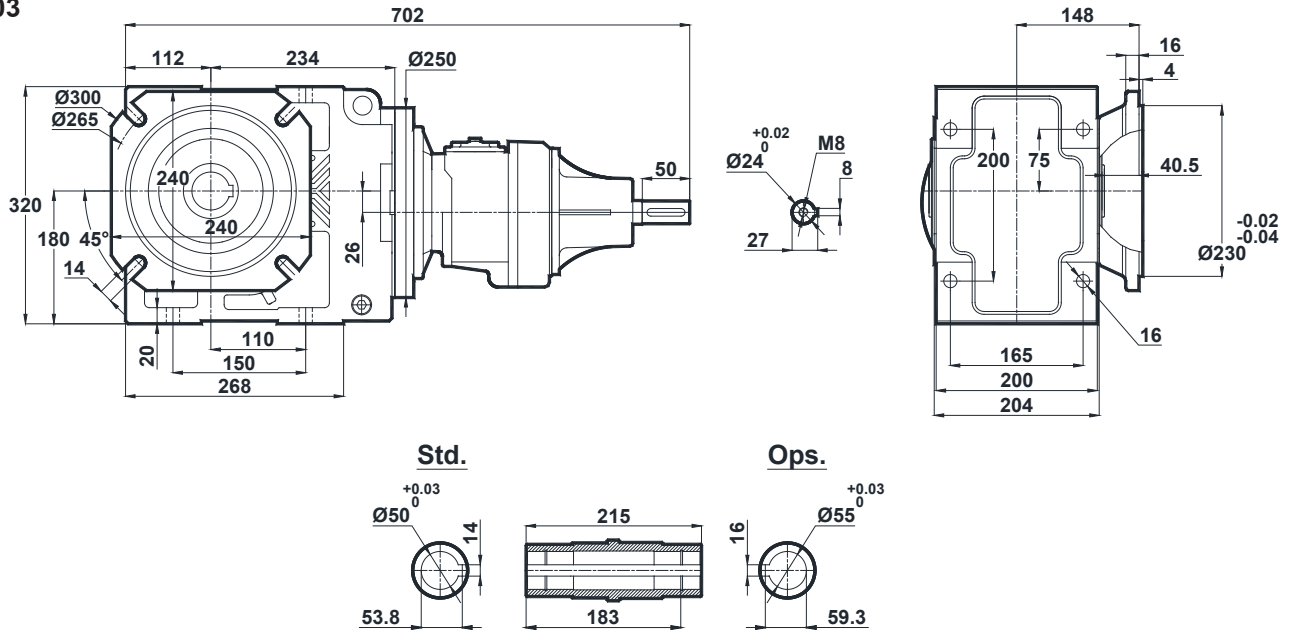

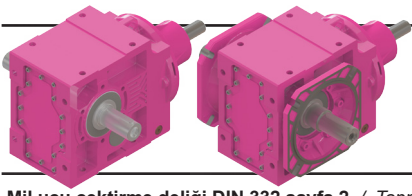

# Ölçü Sayfaları

## Dimension Pages

### Abmessungenseiten

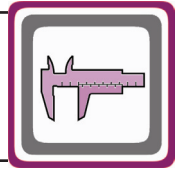

-Mil ucu çekirme deliği DIN 332 sayfa 2 / Tapped center hole to DIN 332, sheet 2 / Zentrierung mit Gewinde DIN 332, Blatt 2

KT475.04  
KT476.04

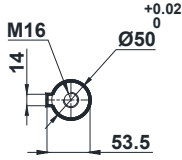
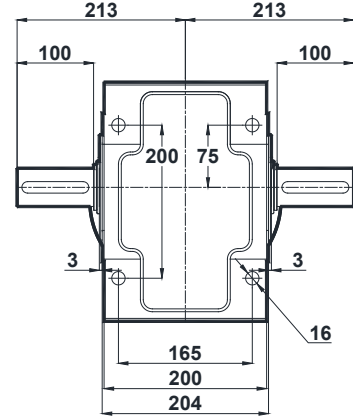
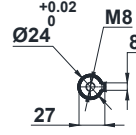
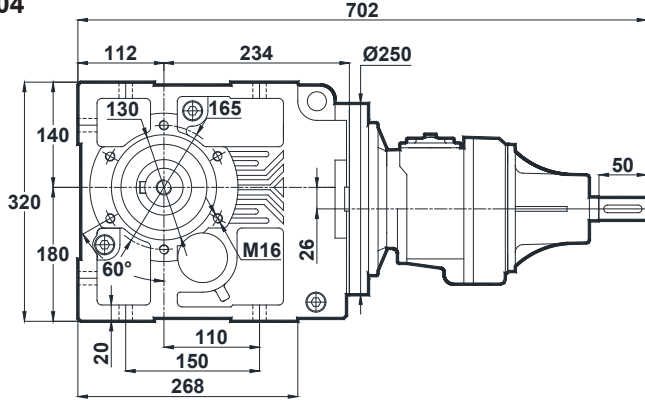

KT475.05  
KT476.05

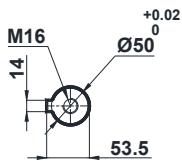
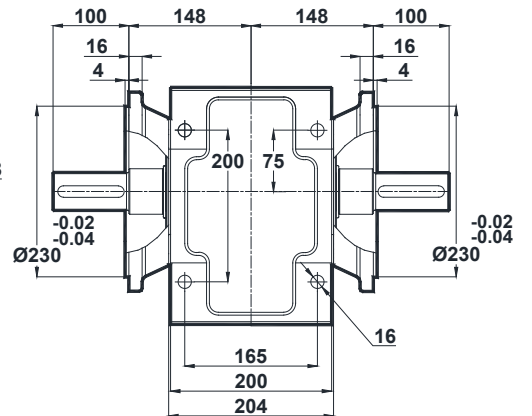
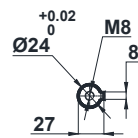
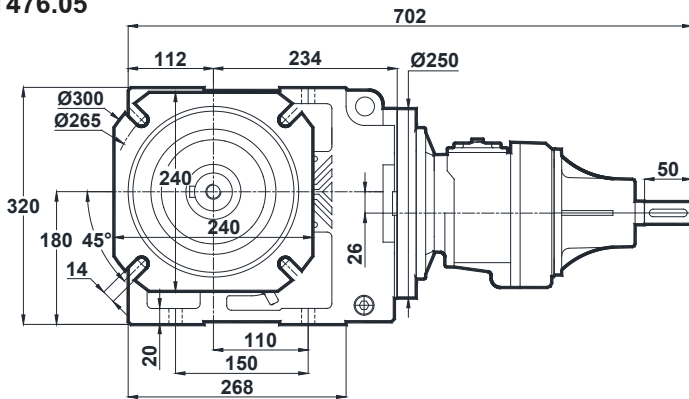





# Ölçü Sayfaları

## Dimension Pages

### Abmessungsseiten



-Mil ucu çekirme deliği DIN 332 sayfa 2 / Tapped center hole to DIN 332, sheet 2 / Zentrierung mit Gewinde DIN 332, Blatt 2

KT475.08  
KT476.08

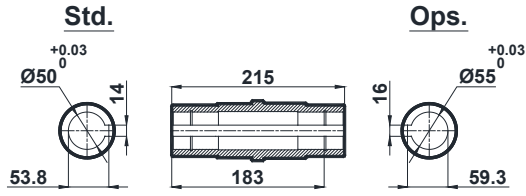
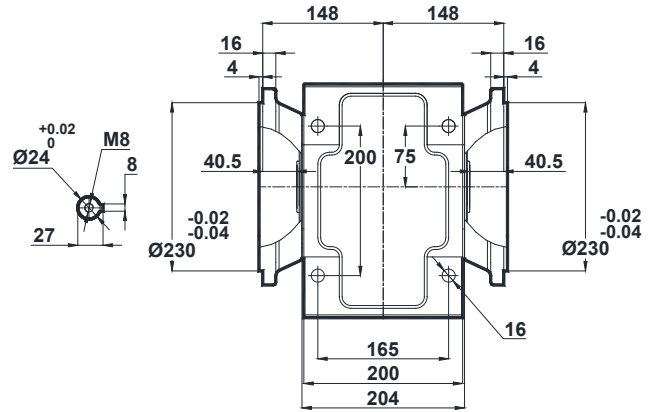
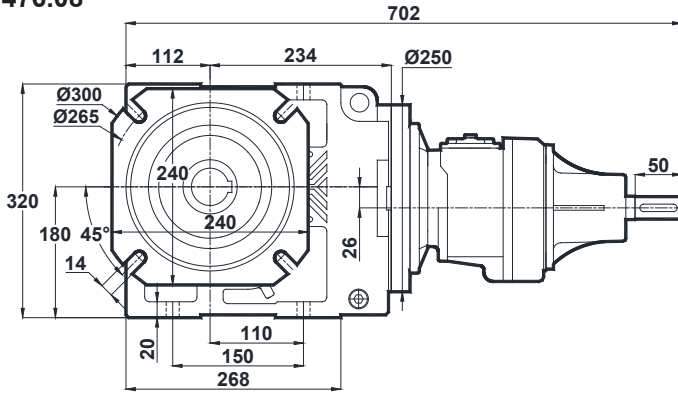



# Ölçü Sayfaları

## Dimension Pages

### Abmessungsseiten

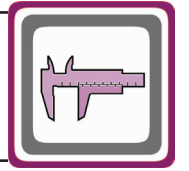

-Mil ucu çekirme deliği DIN 332 sayfa 2 / Tapped center hole to DIN 332, sheet 2 / Zentrierung mit Gewinde DIN 332, Blatt 2

#### KT573.00

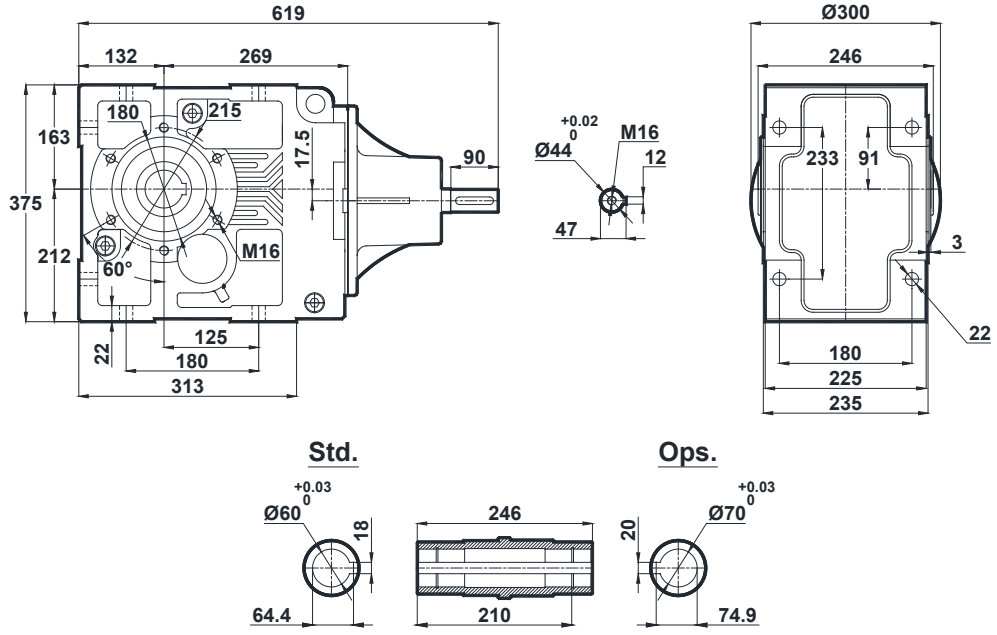

#### KT573.01

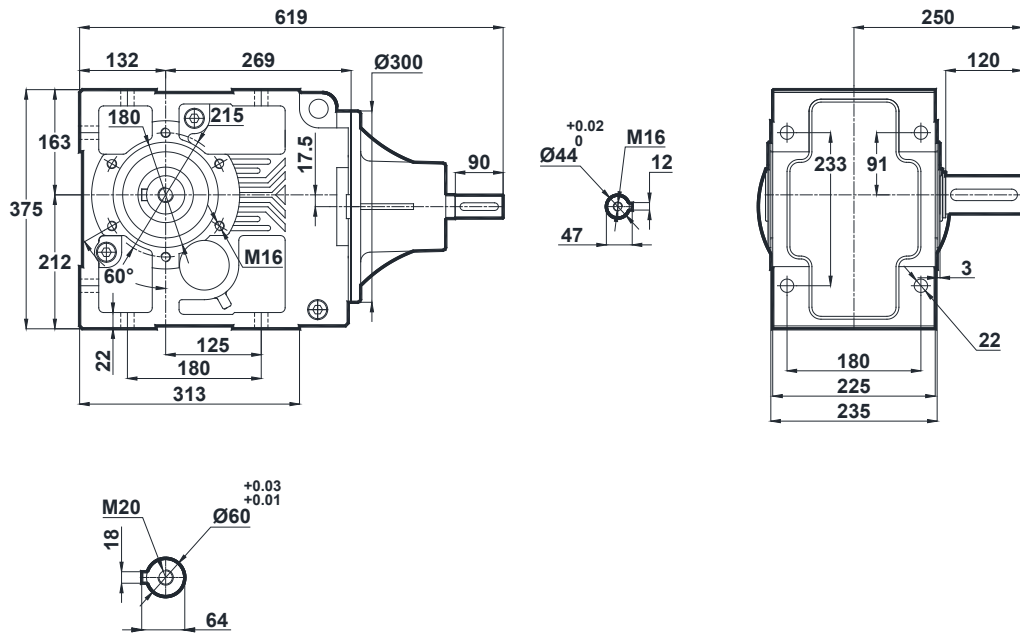



# Ölçü Sayfaları

## Dimension Pages

### Abmessungsseiten



-Mil ucu çekirme deliği DIN 332 sayfa 2 / Tapped center hole to DIN 332, sheet 2 / Zentrierung mit Gewinde DIN 332, Blatt 2

KT573.02

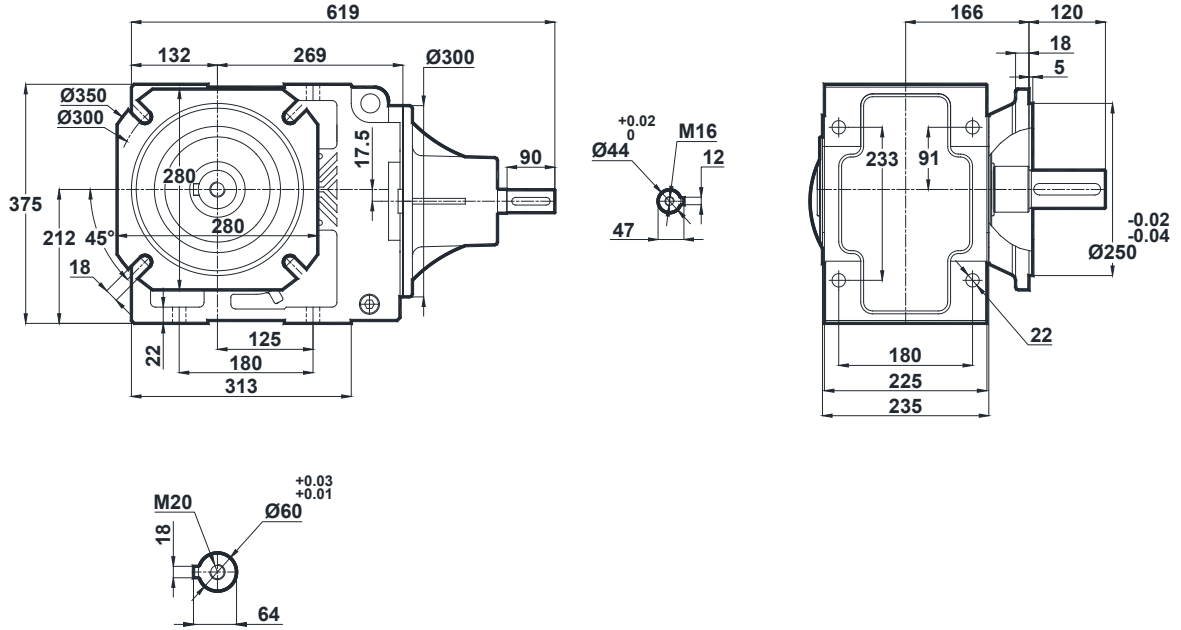

KT573.03

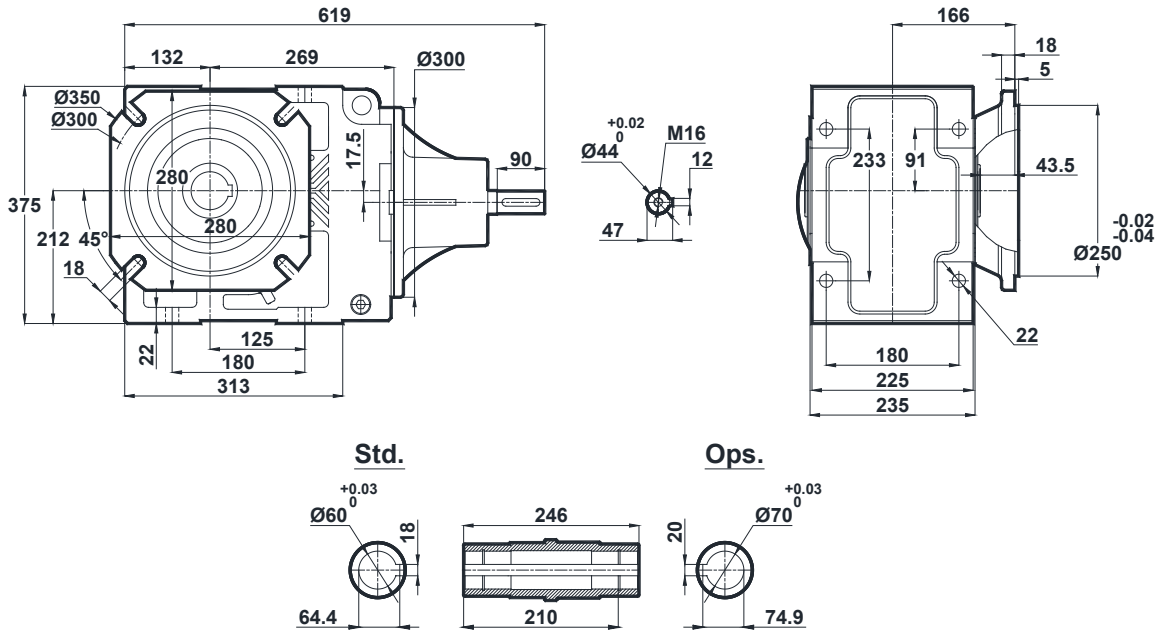

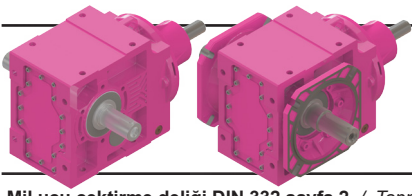

# Ölçü Sayfaları

## Dimension Pages

### Abmessungsseiten

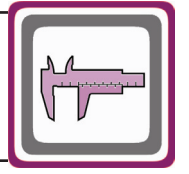

-Mil ucu çekirme deliği DIN 332 sayfa 2 / Tapped center hole to DIN 332, sheet 2 / Zentrierung mit Gewinde DIN 332, Blatt 2

#### KT573.04

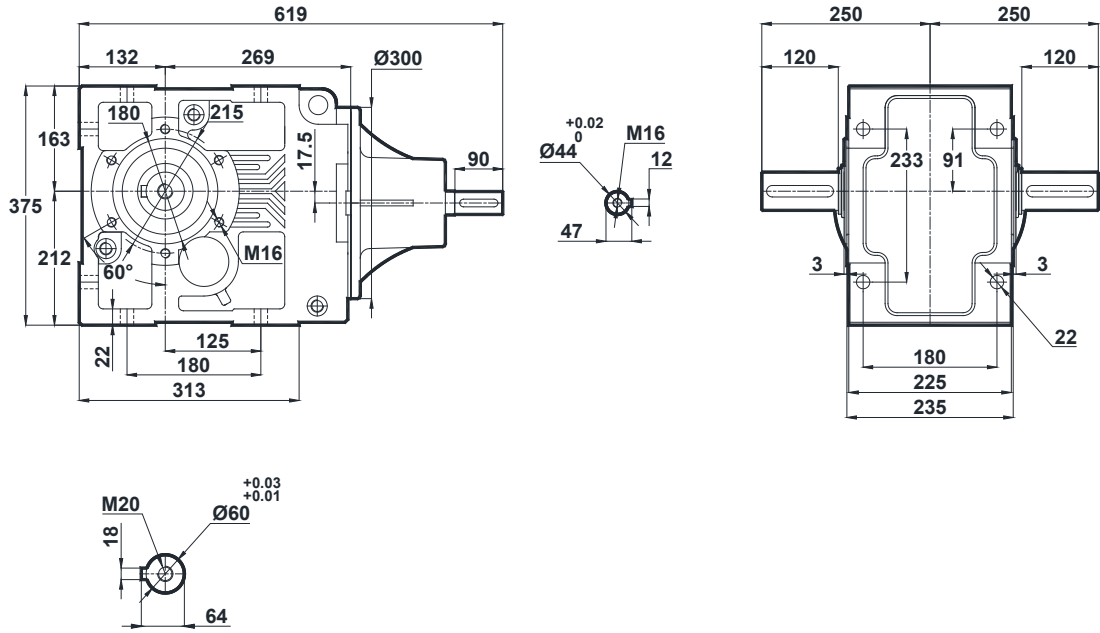

#### KT573.05

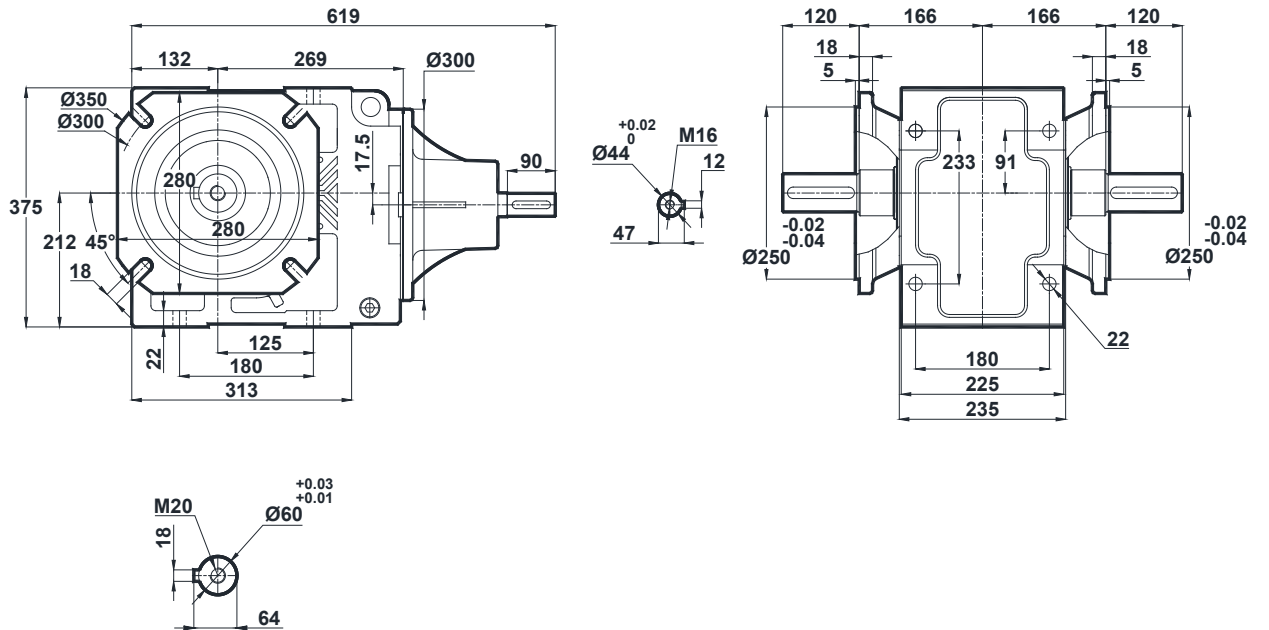



# Ölçü Sayfaları Dimension Pages Abmessungenseiten



-Mil ucu çektirme deliği DIN 332 sayfa 2 / Tapped center hole to DIN 332, sheet 2 / Zentrierung mit Gewinde DIN 332, Blatt 2

KT573.08

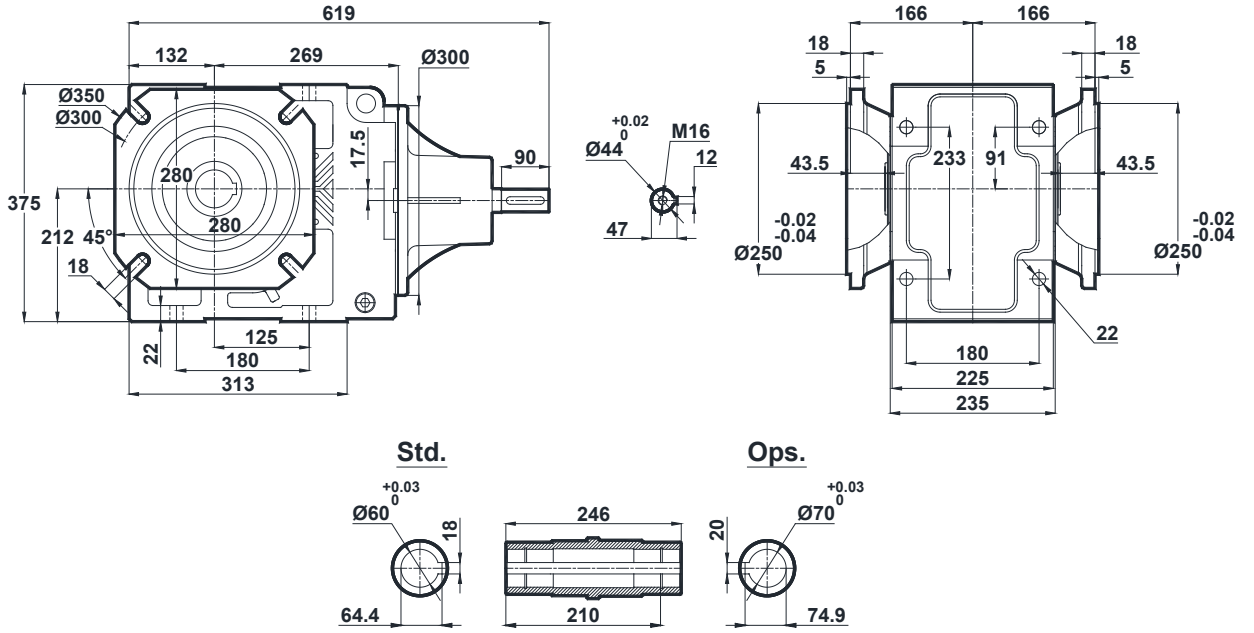



# Ölçü Sayfaları

## Dimension Pages

### Abmessungenseiten

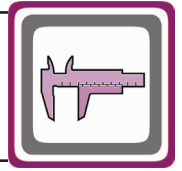

-Mil ucu çekirme deliği DIN 332 sayfa 2 / Tapped center hole to DIN 332, sheet 2 / Zentrierung mit Gewinde DIN 332, Blatt 2

KT574.00

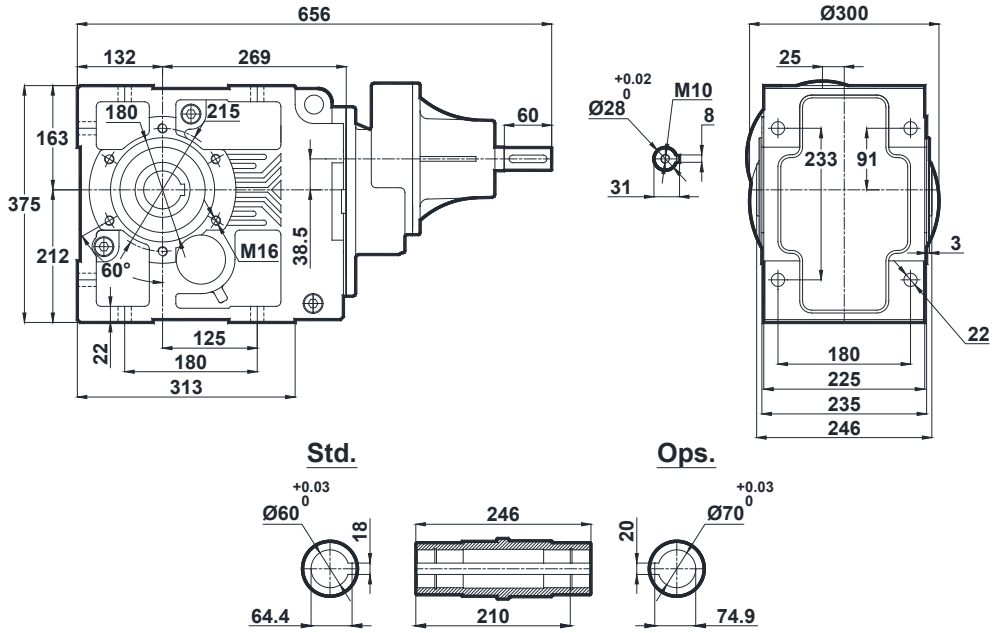

KT574.01

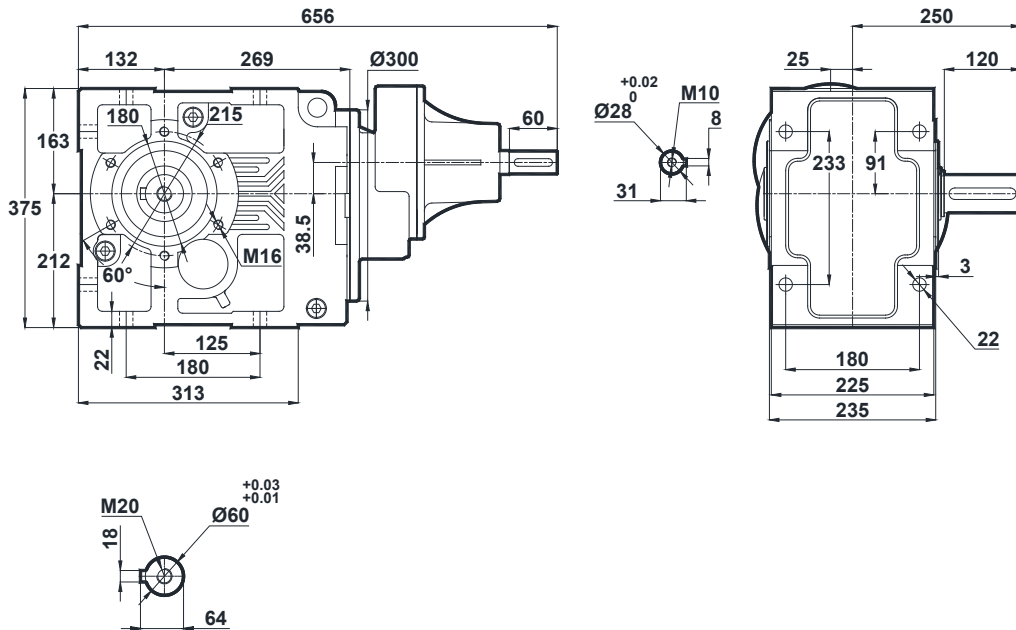



# Ölçü Sayfaları

## Dimension Pages

### Abmessungsseiten



-Mil ucu çekirme deliği DIN 332 sayfa 2 / Tapped center hole to DIN 332, sheet 2 / Zentrierung mit Gewinde DIN 332, Blatt 2

#### KT574.02

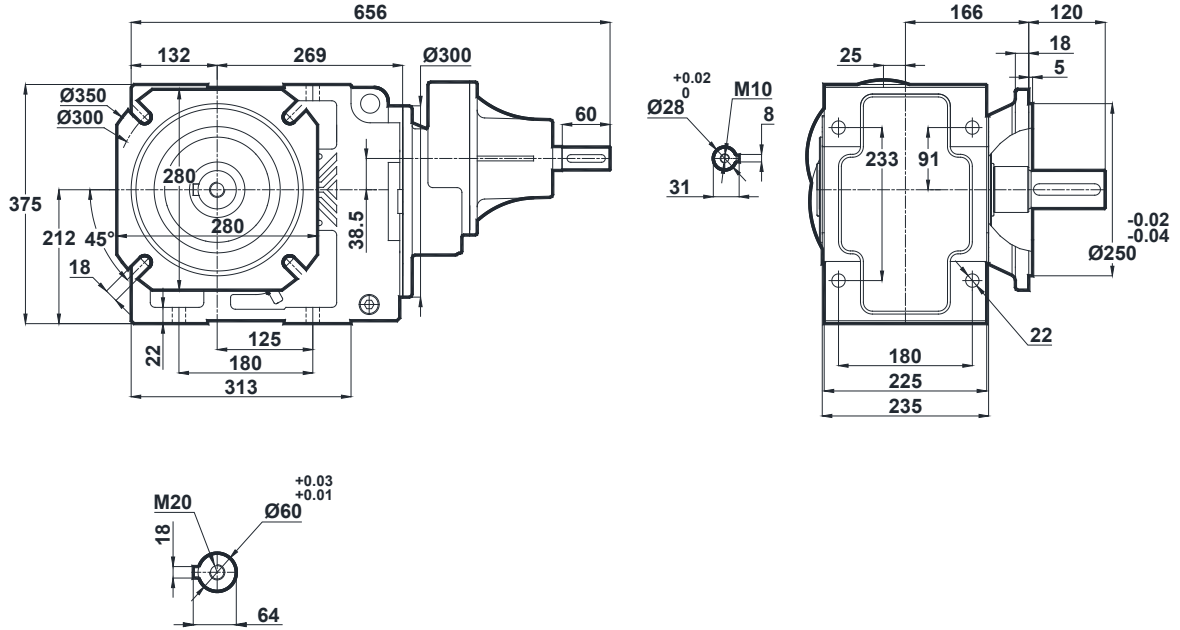

#### KT574.03

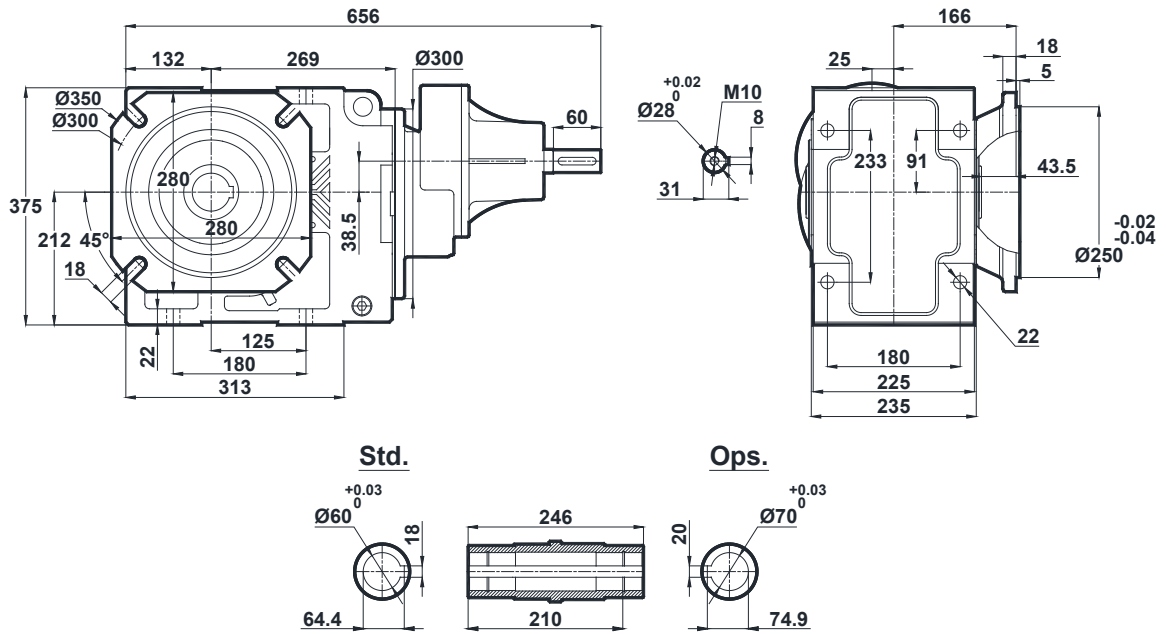

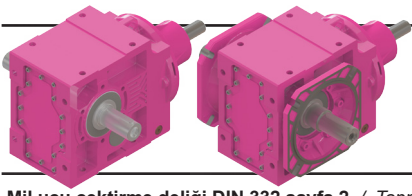

# Ölçü Sayfaları Dimension Pages Abmessungenseiten

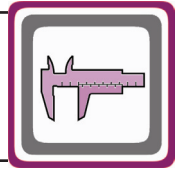

-Mil ucu çekirme deliği DIN 332 sayfa 2 / Tapped center hole to DIN 332, sheet 2 / Zentrierung mit Gewinde DIN 332, Blatt 2

## KT574.04

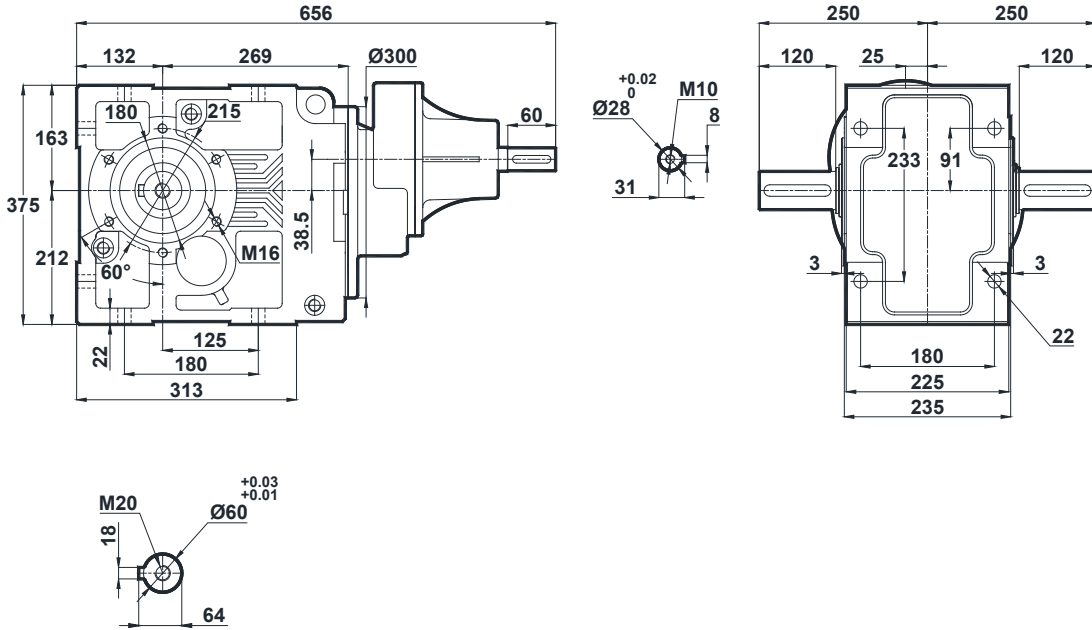

## KT574.05

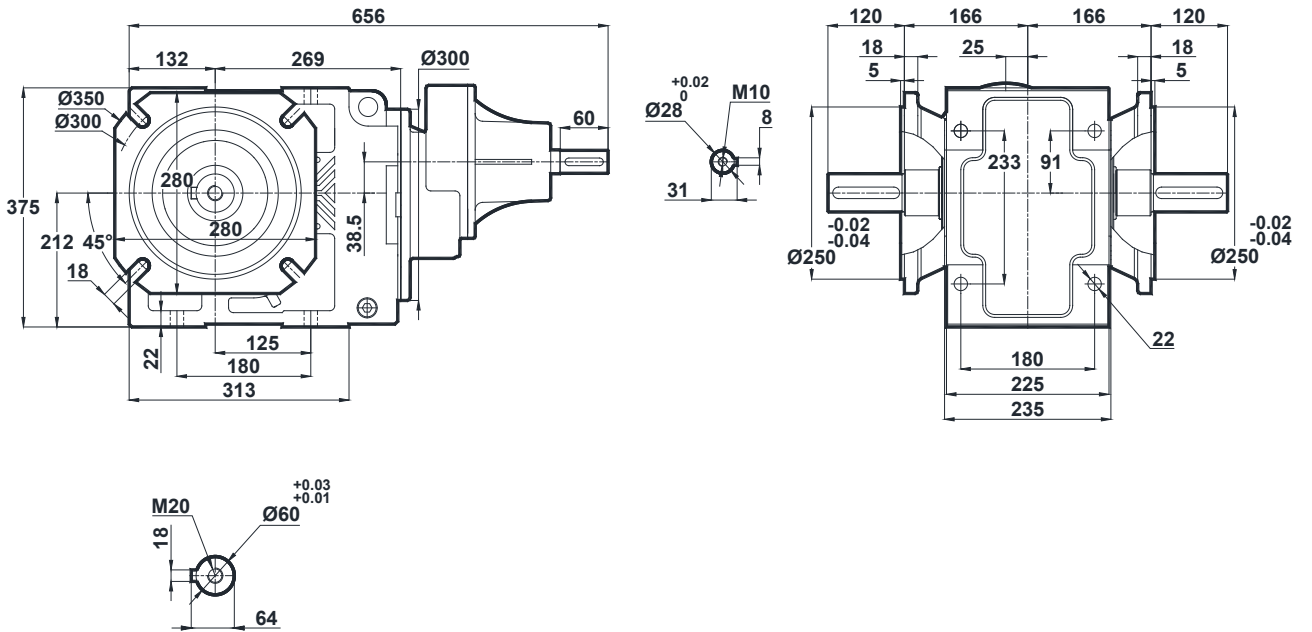







# Ölçü Sayfaları

## Dimension Pages

### Abmessungenseiten

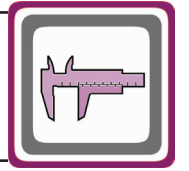

-Mil ucu çektirme deliği DIN 332 sayfa 2 / Tapped center hole to DIN 332, sheet 2 / Zentrierung mit Gewinde DIN 332, Blatt 2

KT575.00  
KT576.00

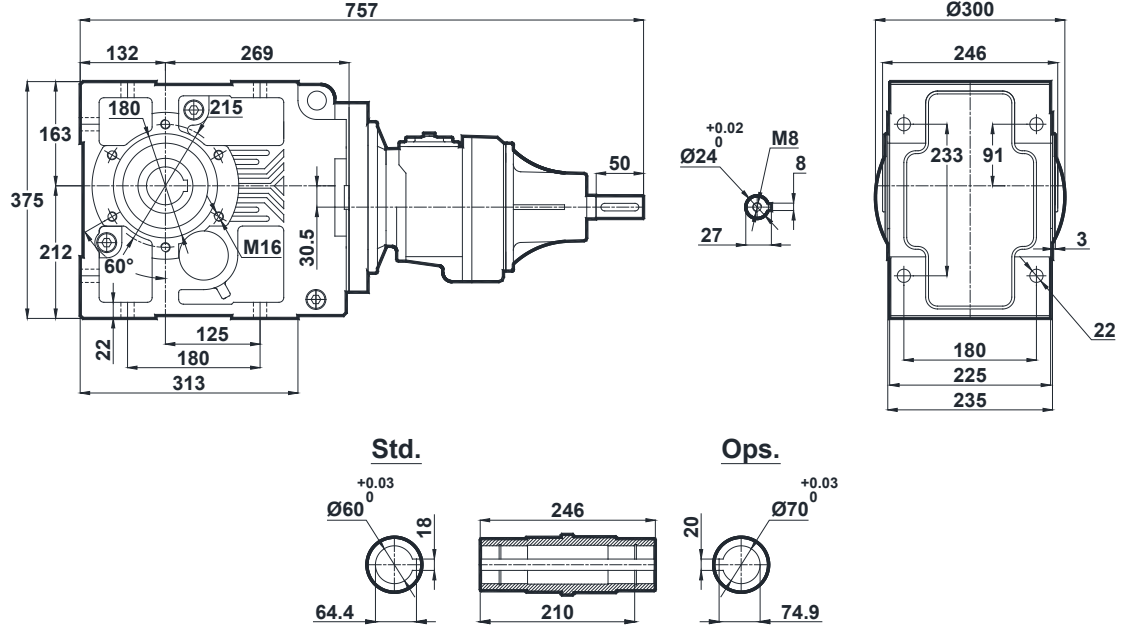

KT575.01  
KT576.01

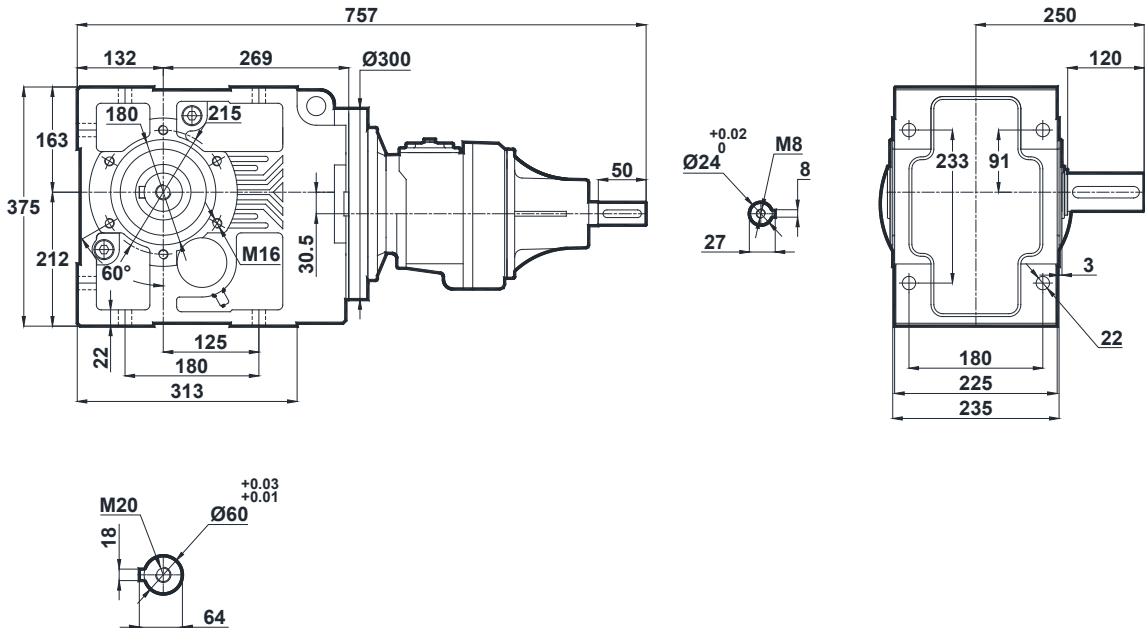



# Ölçü Sayfaları

## Dimension Pages

### Abmessungsseiten

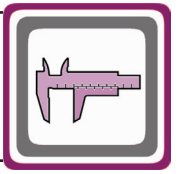

-Mil ucu çekirme deliği DIN 332 sayfa 2 / Tapped center hole to DIN 332, sheet 2 / Zentrierung mit Gewinde DIN 332, Blatt 2

KT575.02  
KT576.02

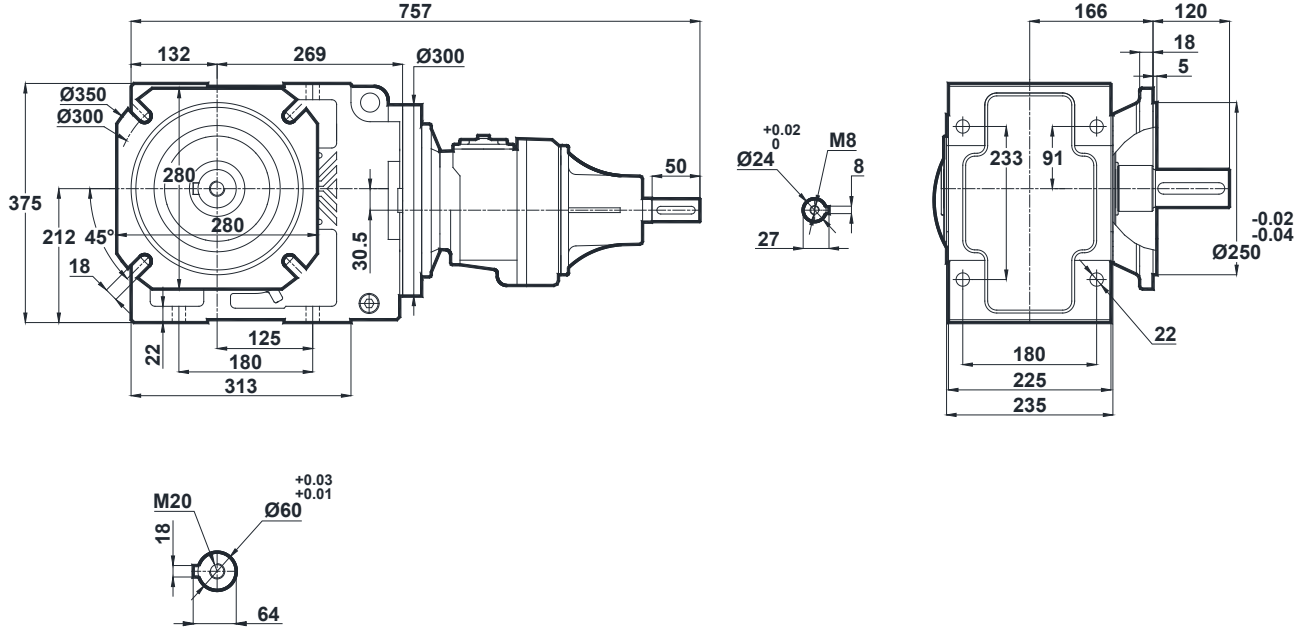

KT575.03  
KT576.03

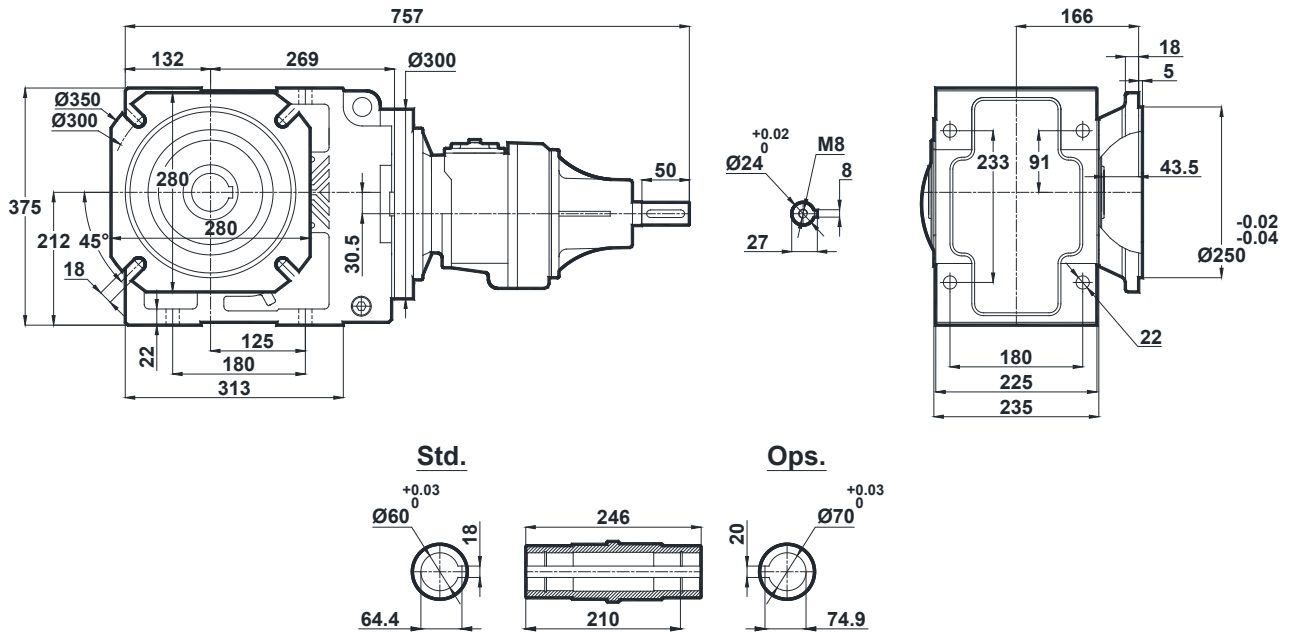

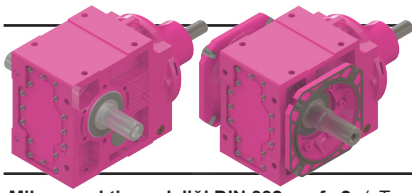

# Ölçü Sayfaları

## Dimension Pages

### Abmessungsseiten

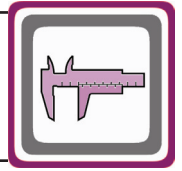

-Mil ucu çekirme deliği DIN 332 sayfa 2 / Tapped center hole to DIN 332, sheet 2 / Zentrierung mit Gewinde DIN 332, Blatt 2

KT575.04  
KT576.04

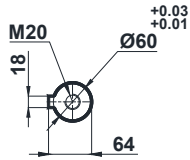
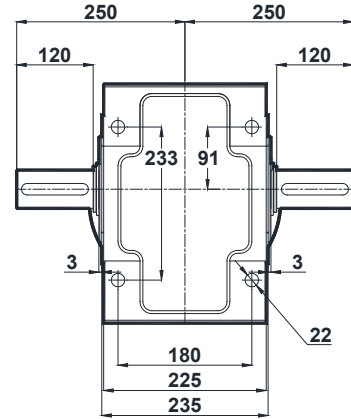
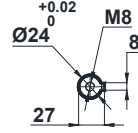
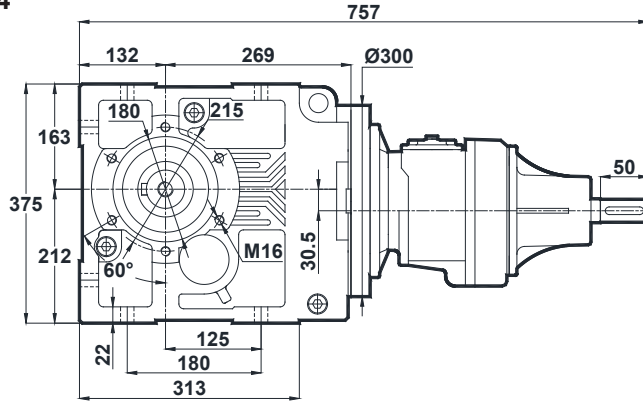

KT575.05  
KT576.05

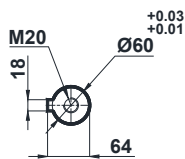
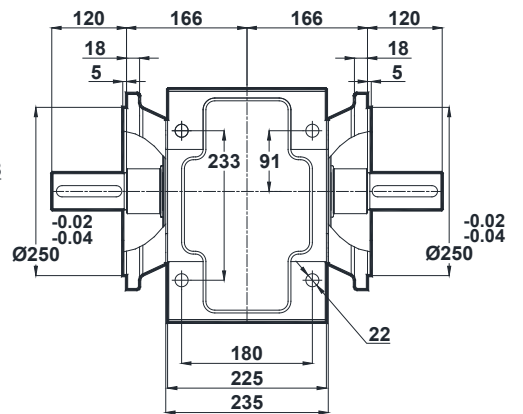
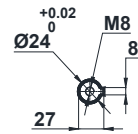
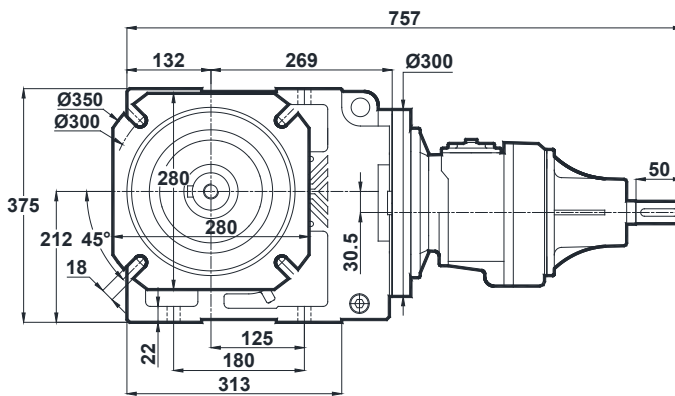



# Ölçü Sayfaları Dimension Pages Abmessungsseiten



-Mil ucu çekirme deliği DIN 332 sayfa 2 / Tapped center hole to DIN 332, sheet 2 / Zentrierung mit Gewinde DIN 332, Blatt 2

KT575.08  
KT576.08

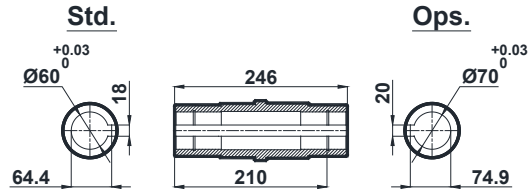
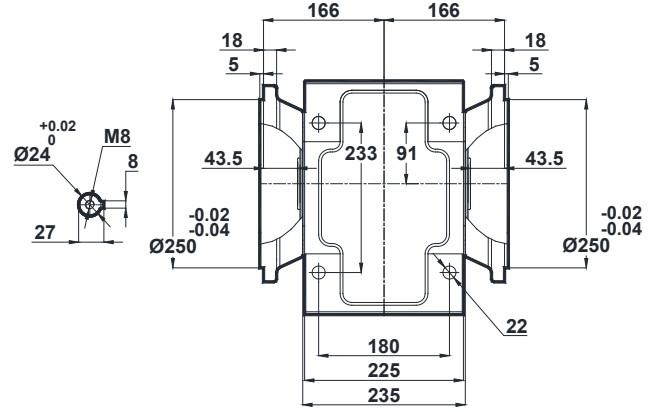
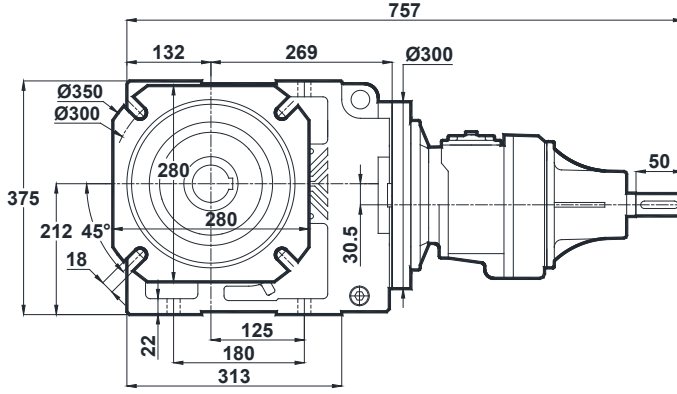



# Ölçü Sayfaları

## Dimension Pages

### Abmessungenseiten

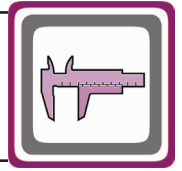

-Mil ucu çekirme deliği DIN 332 sayfa 2 / Tapped center hole to DIN 332, sheet 2 / Zentrierung mit Gewinde DIN 332, Blatt 2

KT673.00

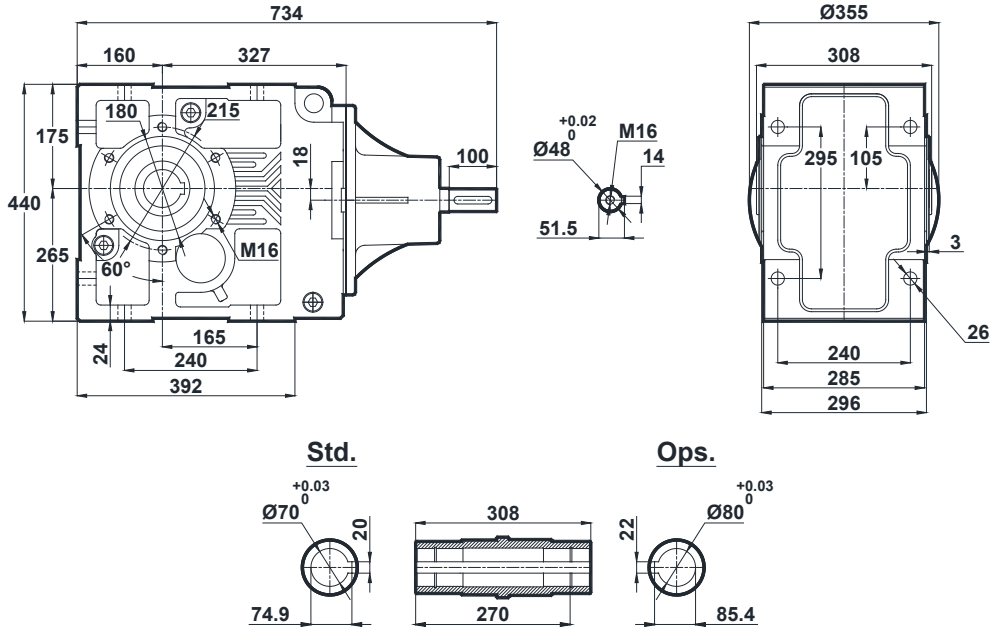

KT673.01

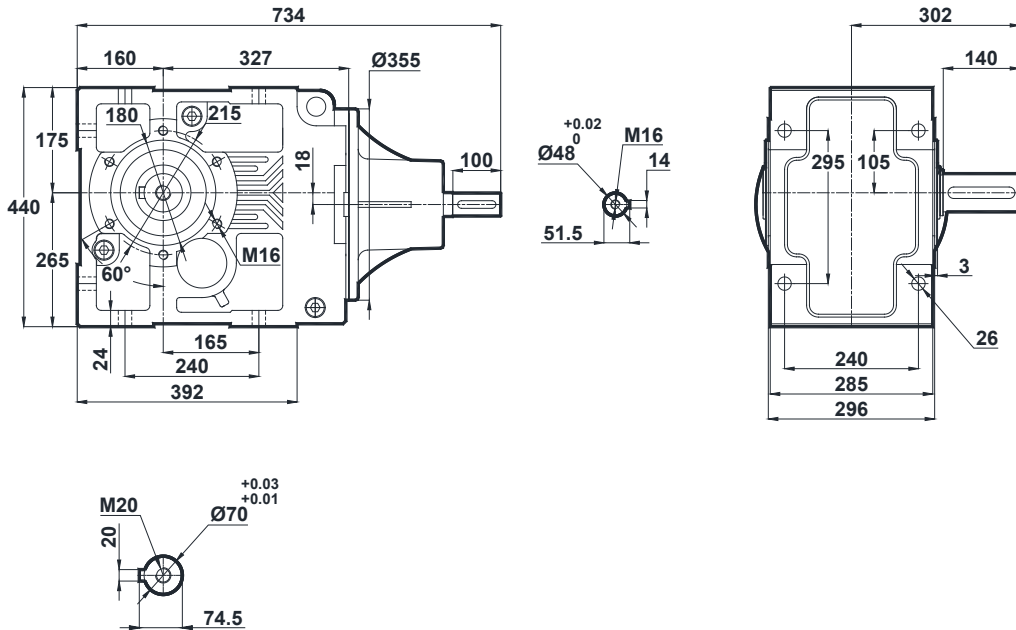



# Ölçü Sayfaları

## Dimension Pages

### Abmessungenseiten

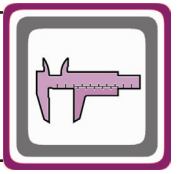

-Mil ucu çekirme deliği DIN 332 sayfa 2 / Tapped center hole to DIN 332, sheet 2 / Zentrierung mit Gewinde DIN 332, Blatt 2

KT673.02

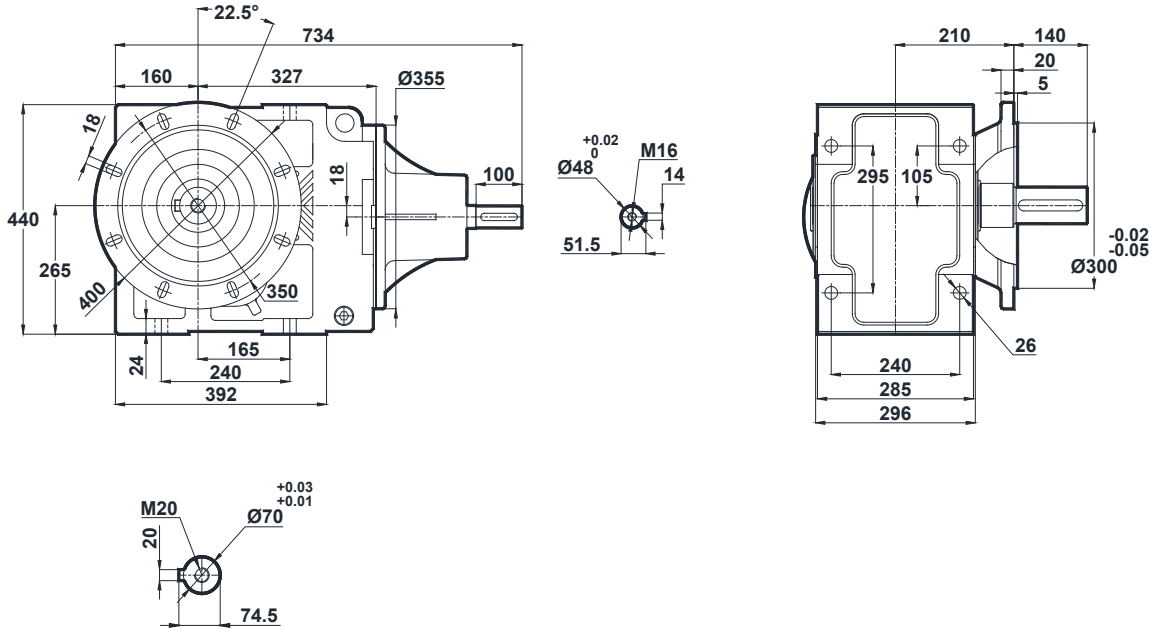

KT673.03

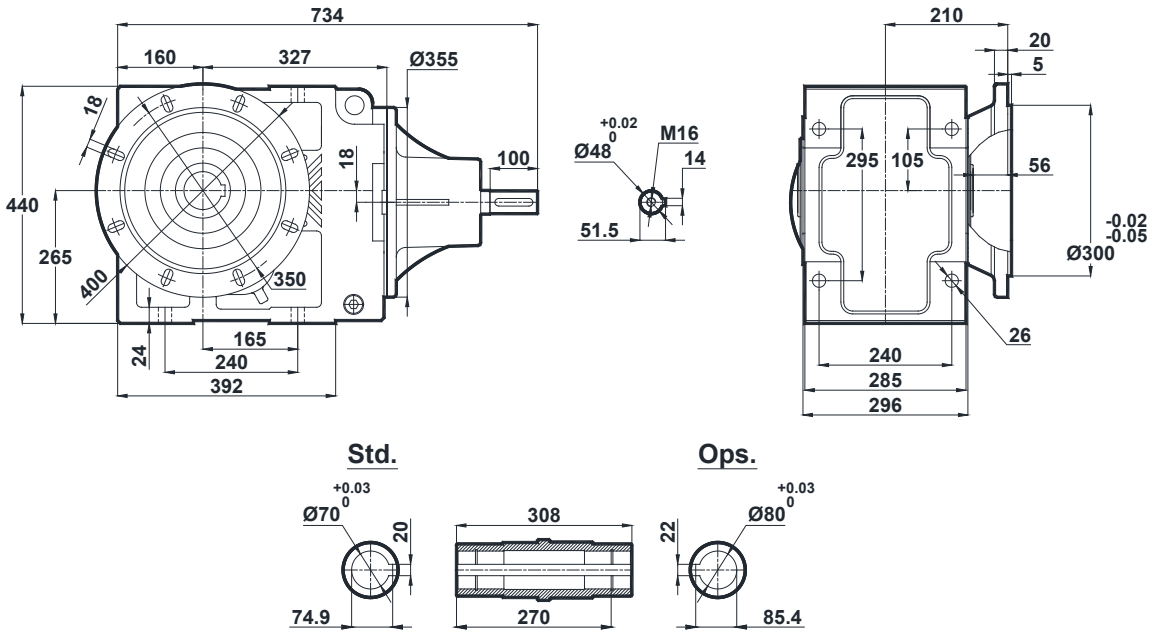

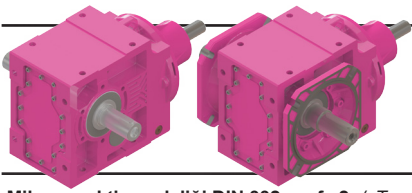

# Ölçü Sayfaları

## Dimension Pages

### Abmessungsseiten

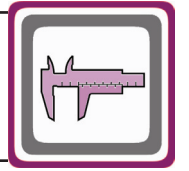

-Mil ucu çekirme deliği DIN 332 sayfa 2 / Tapped center hole to DIN 332, sheet 2 / Zentrierung mit Gewinde DIN 332, Blatt 2

#### KT673.04

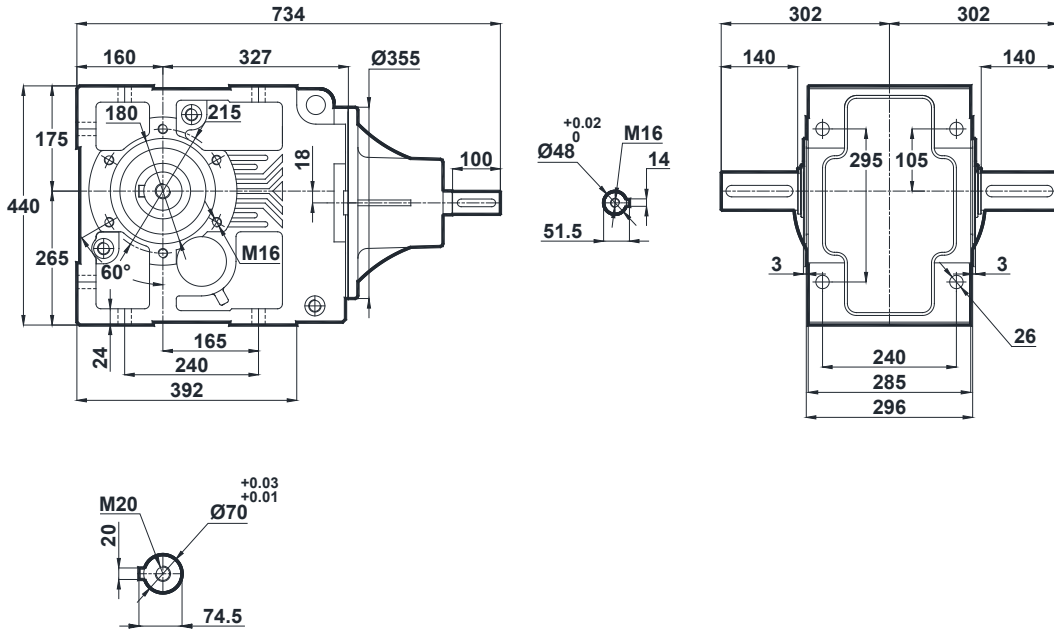

#### KT673.05

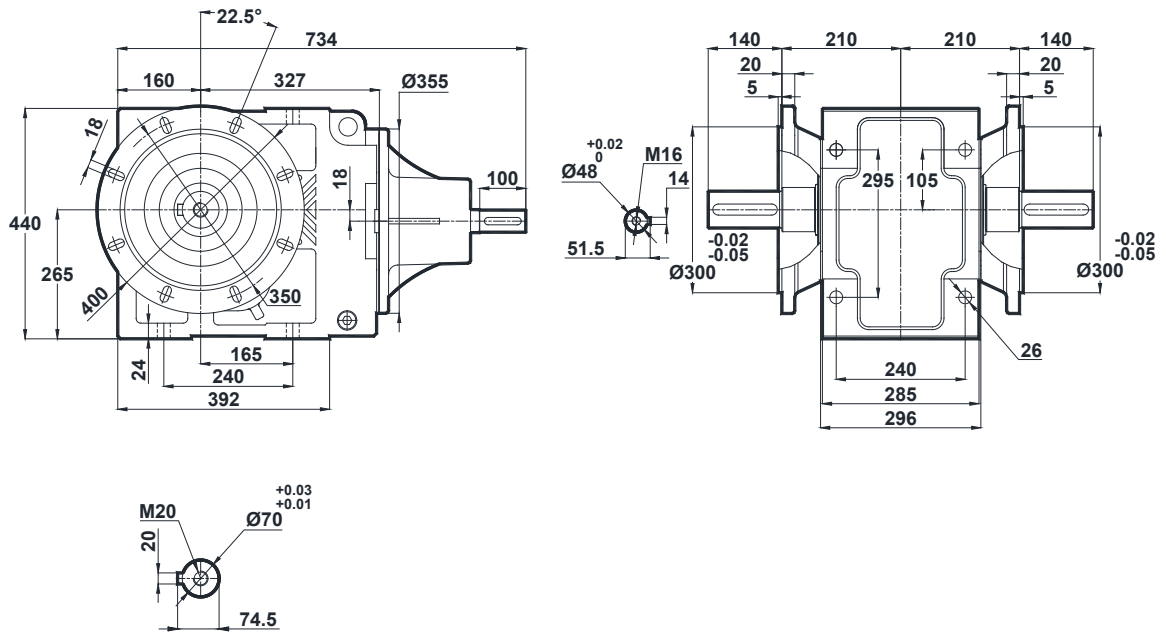





# Ölçü Sayfaları Dimension Pages Abmessungenseiten



-Mil ucu çektirme deliği DIN 332 sayfa 2 / Tapped center hole to DIN 332, sheet 2 / Zentrierung mit Gewinde DIN 332, Blatt 2

KT673.08

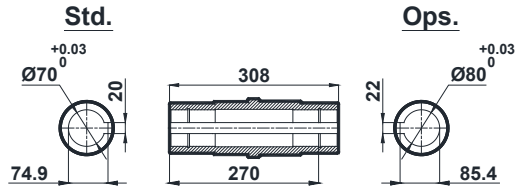
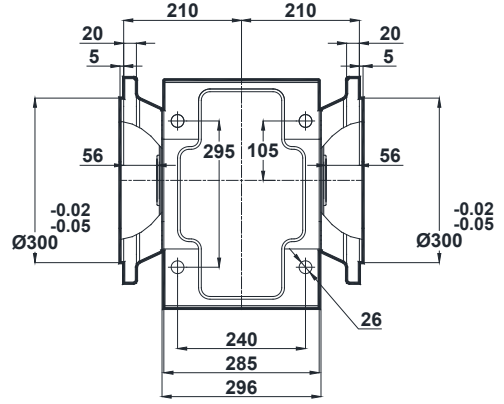
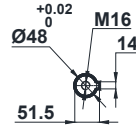
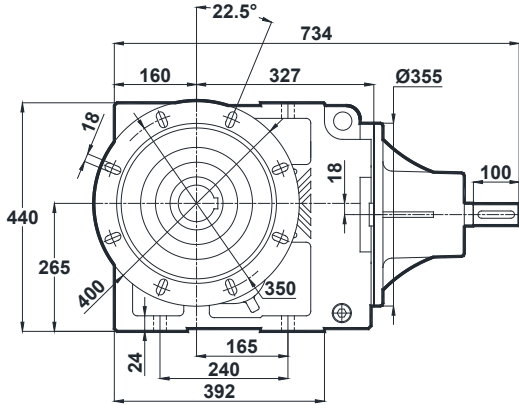



# Ölçü Sayfaları

## Dimension Pages

### Abmessungenseiten

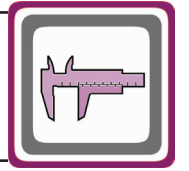

-Mil ucu çektirme deliği DIN 332 sayfa 2 / Tapped center hole to DIN 332, sheet 2 / Zentrierung mit Gewinde DIN 332, Blatt 2

#### KT674.00

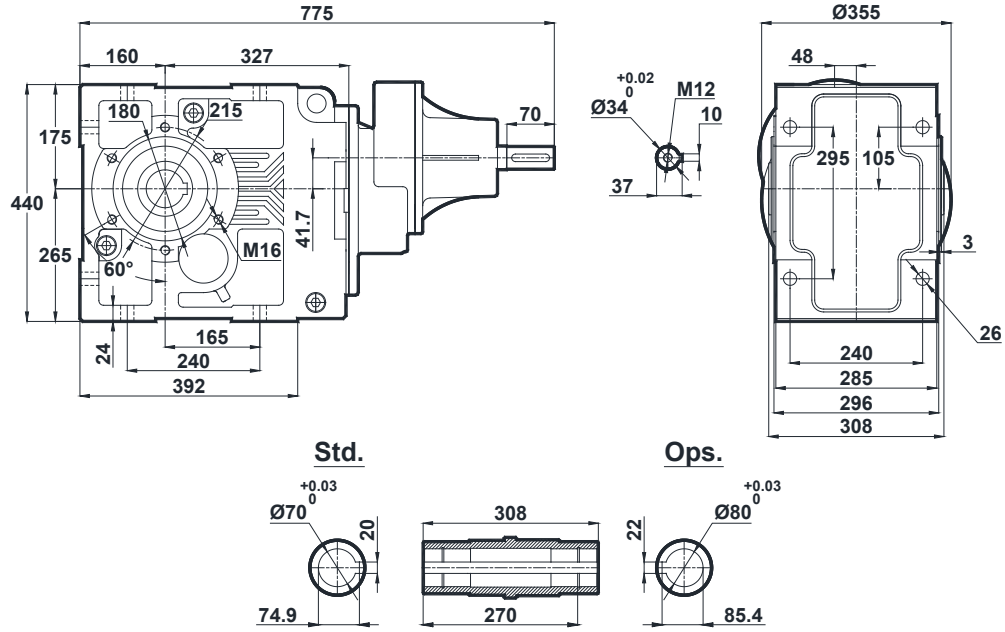

#### KT674.01

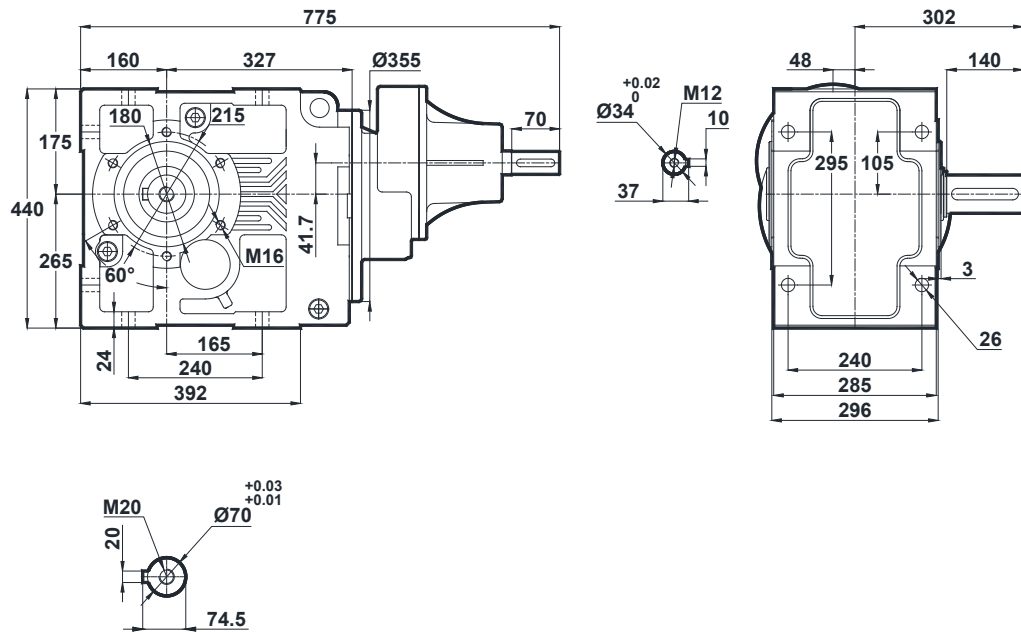



# Ölçü Sayfaları

## Dimension Pages

### Abmessungsseiten



-Mil ucu çekirme deliği DIN 332 sayfa 2 / Tapped center hole to DIN 332, sheet 2 / Zentrierung mit Gewinde DIN 332, Blatt 2

#### KT674.02

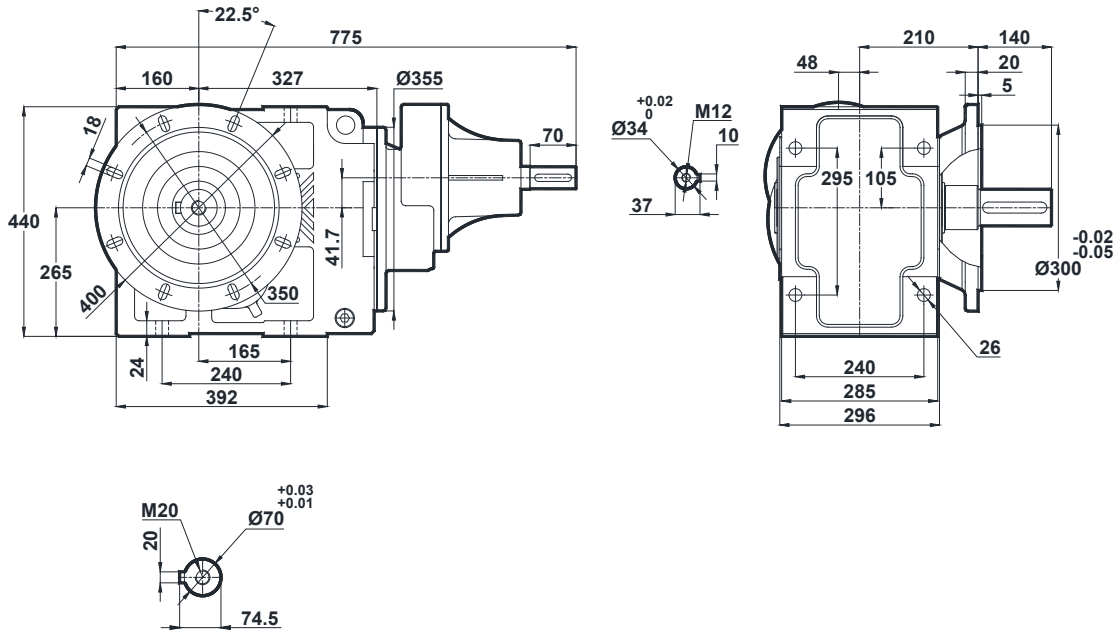

#### KT674.03

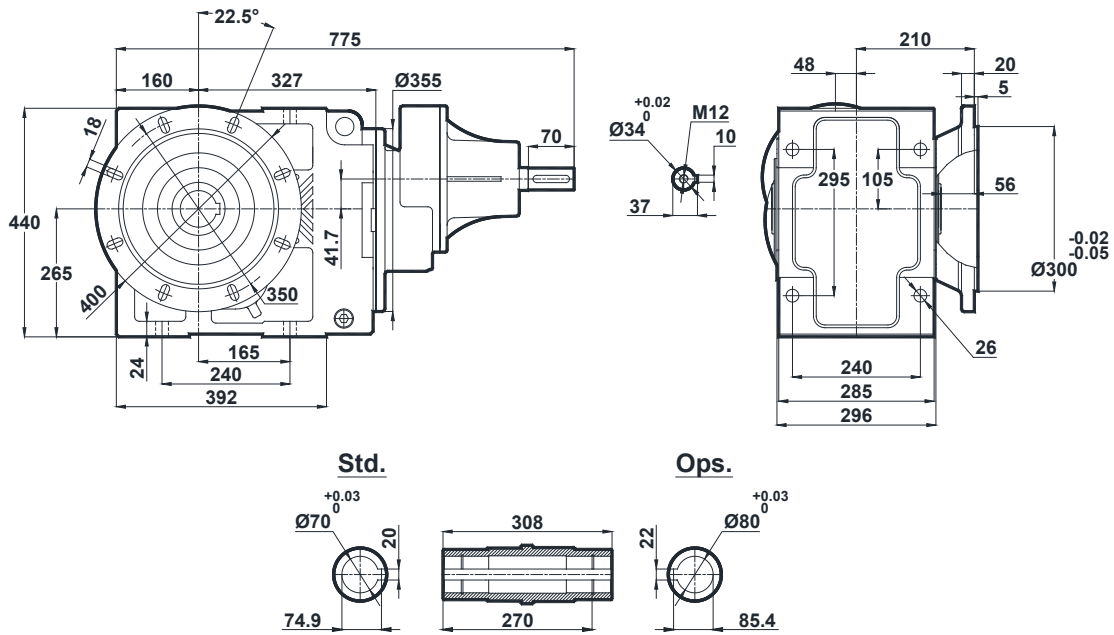

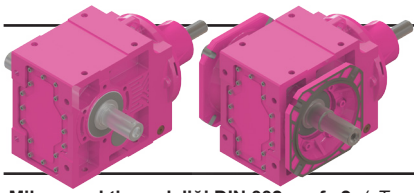

# Ölçü Sayfaları

## Dimension Pages

### Abmessungsseiten

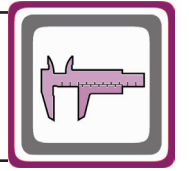

-Mil ucu çekirme deliği DIN 332 sayfa 2 / Tapped center hole to DIN 332, sheet 2 / Zentrierung mit Gewinde DIN 332, Blatt 2

#### KT674.04

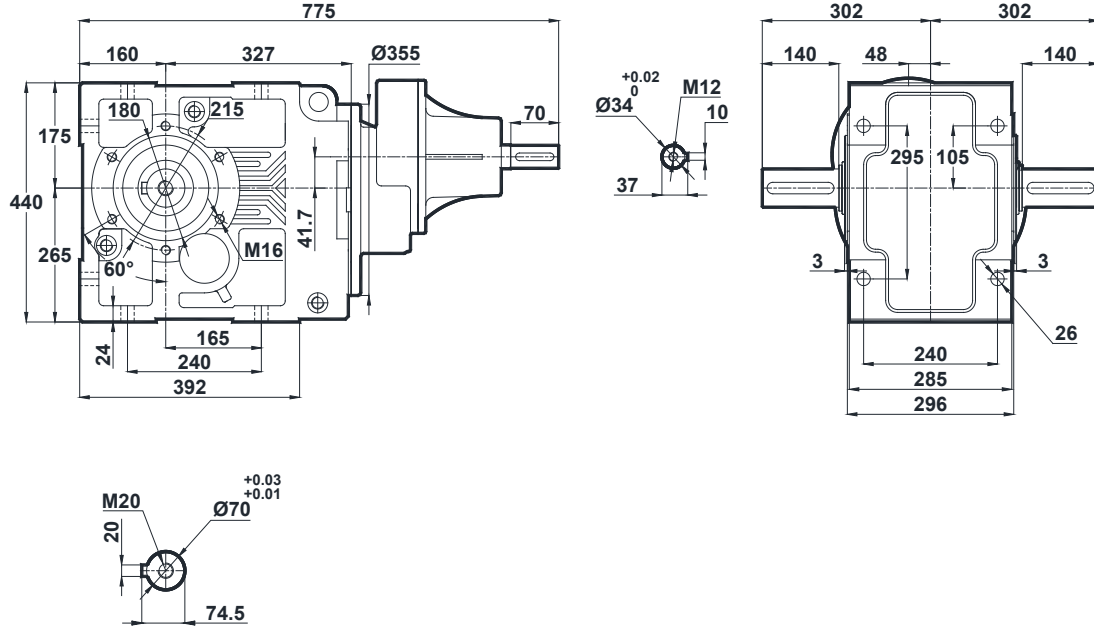

#### KT674.05

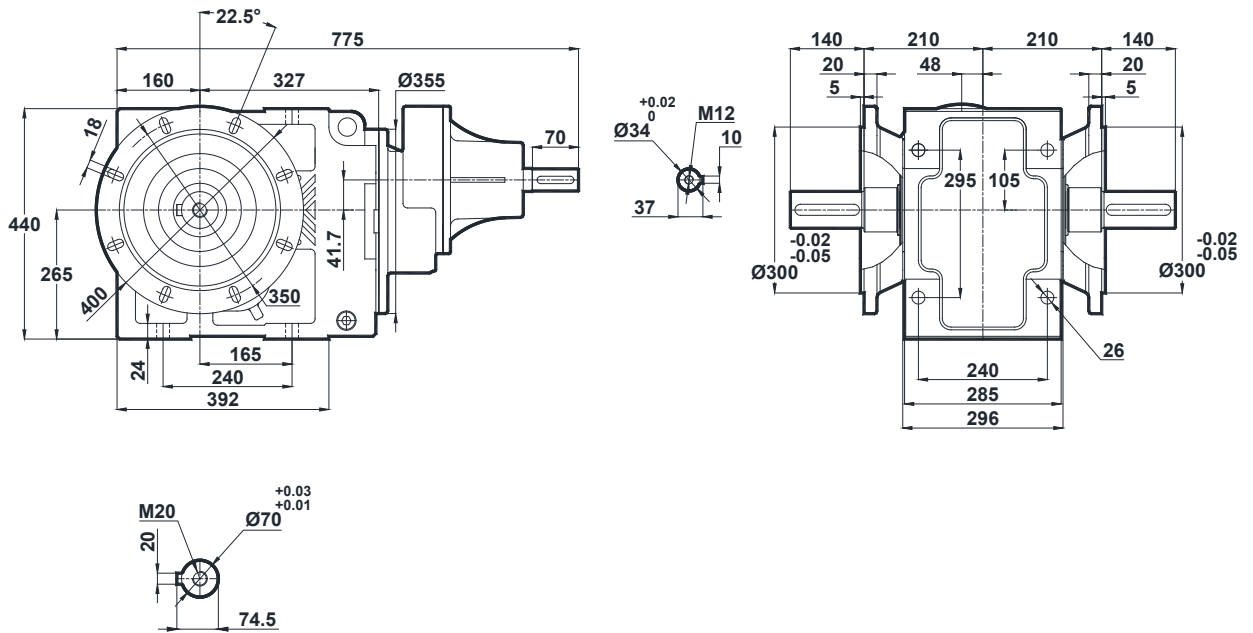



# Ölçü Sayfaları Dimension Pages Abmessungenseiten



-Mil ucu çekirme deliği DIN 332 sayfa 2 / Tapped center hole to DIN 332, sheet 2 / Zentrierung mit Gewinde DIN 332, Blatt 2

KT674.08

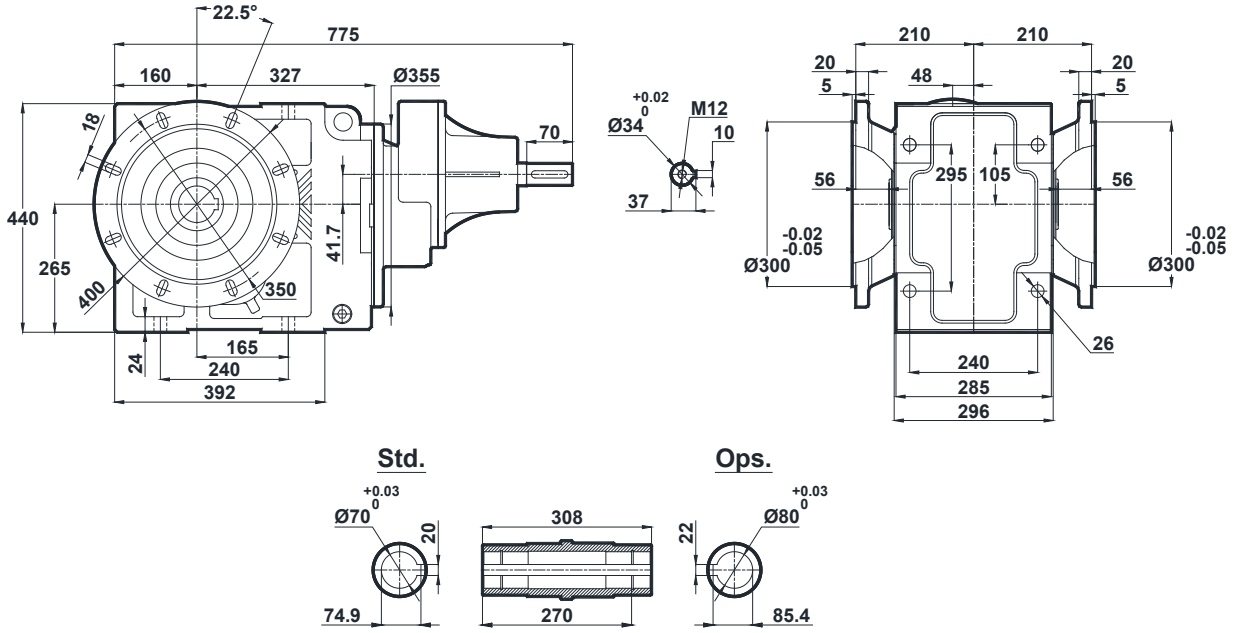



# Ölçü Sayfaları

## Dimension Pages

### Abmessungsseiten

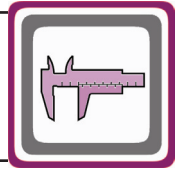

-Mil ucu çektirme deliği DIN 332 sayfa 2 / Tapped center hole to DIN 332, sheet 2 / Zentrierung mit Gewinde DIN 332, Blatt 2

KT675.00  
KT676.00

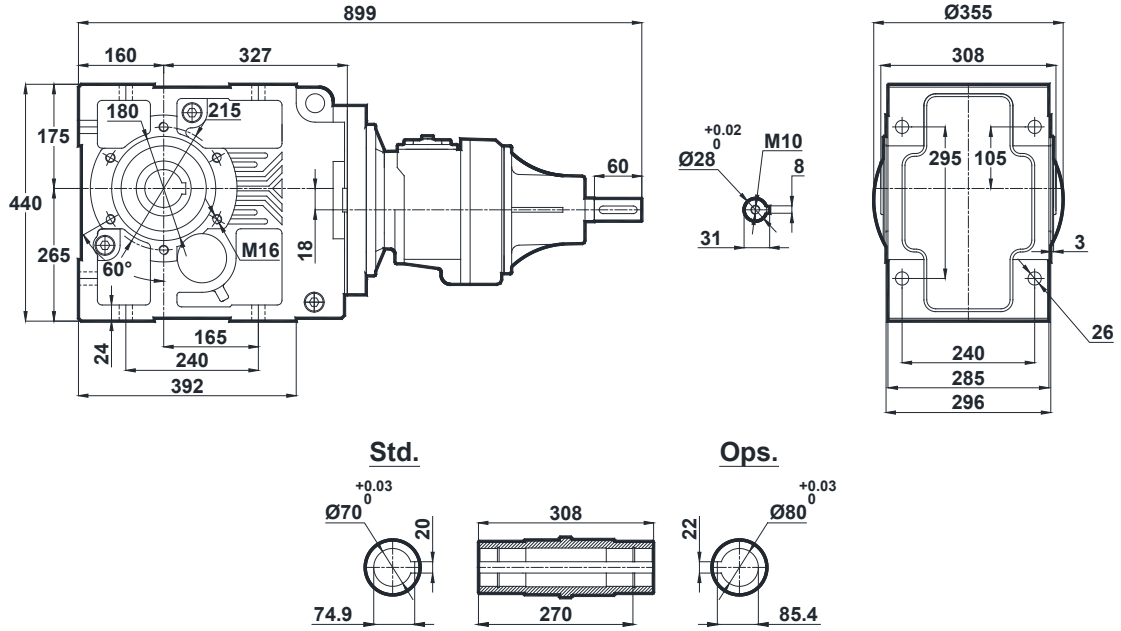

KT675.01  
KT676.01

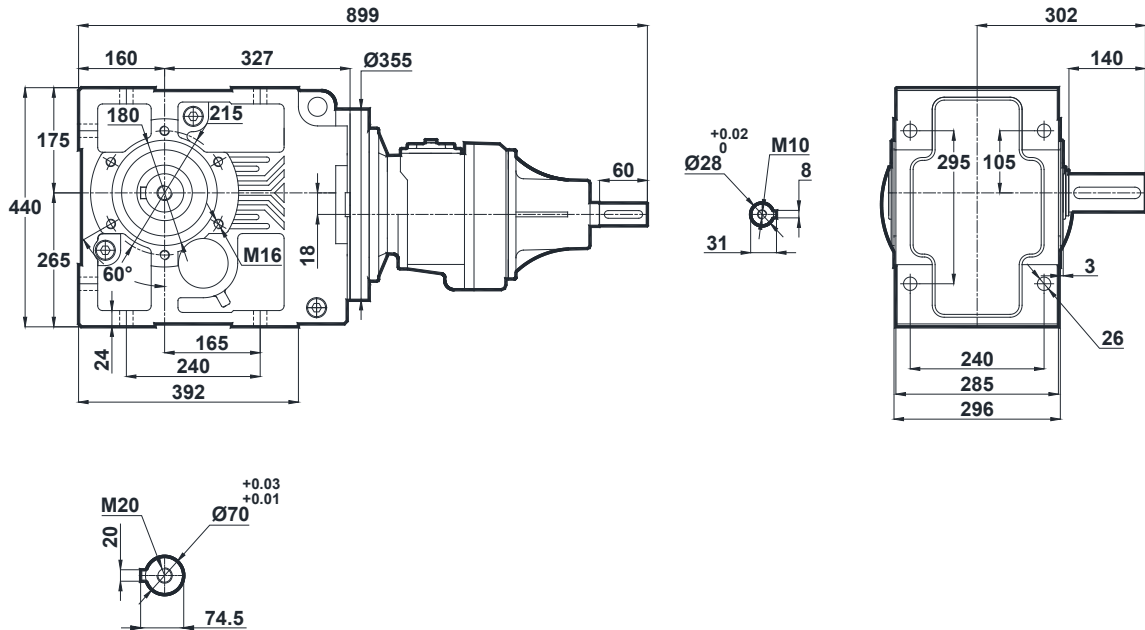



# Ölçü Sayfaları

## Dimension Pages

### Abmessungsseiten



-Mil ucu çektirme deliği DIN 332 sayfa 2 / Tapped center hole to DIN 332, sheet 2 / Zentrierung mit Gewinde DIN 332, Blatt 2

KT675.02  
KT676.02

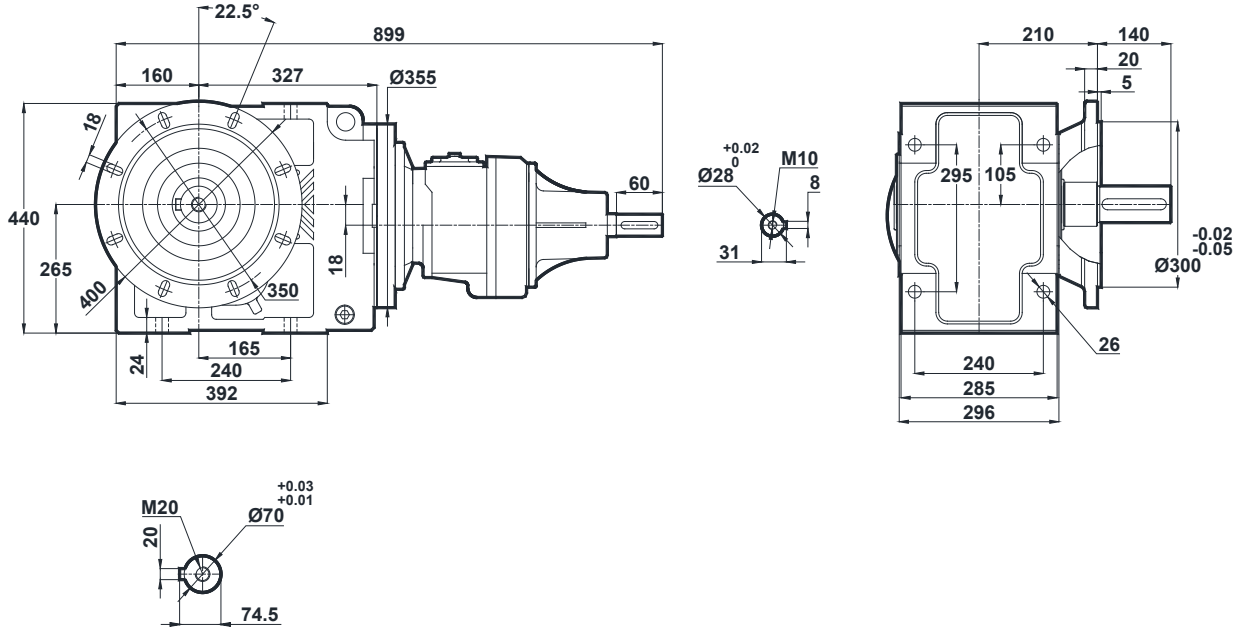

KT675.03  
KT676.03

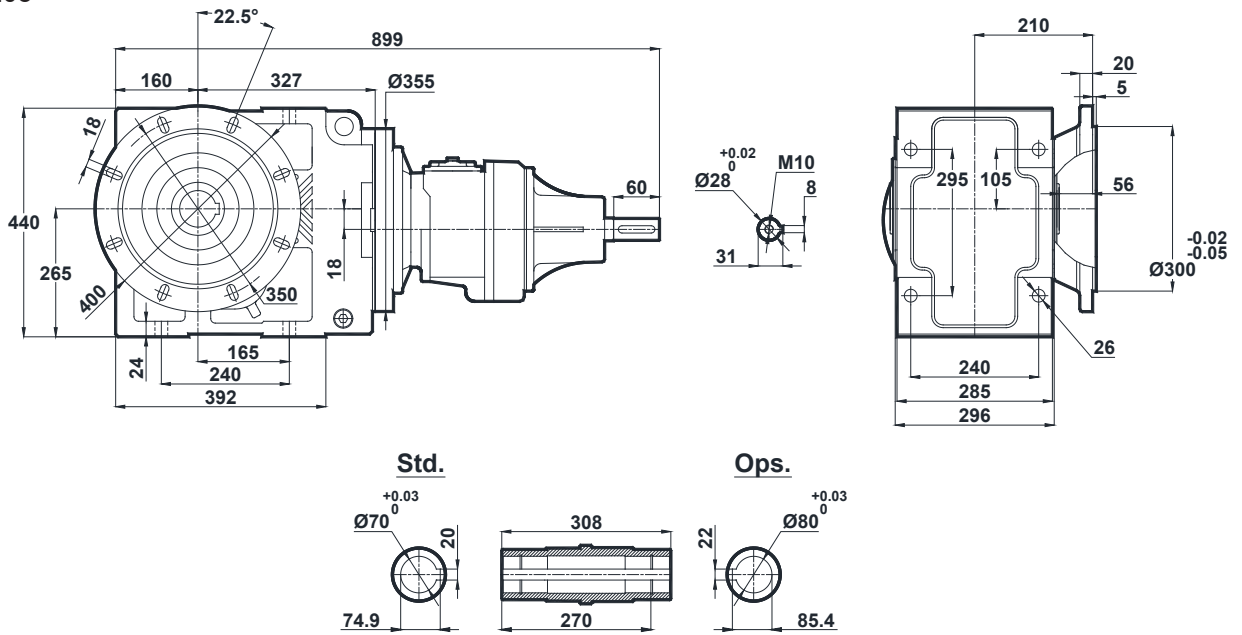

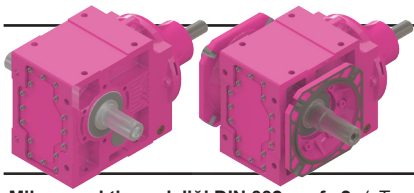

# Ölçü Sayfaları

## Dimension Pages

### Abmessungsseiten

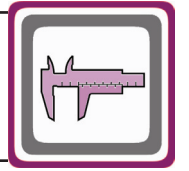

-Mil ucu çektirme deliği DIN 332 sayfa 2 / Tapped center hole to DIN 332, sheet 2 / Zentrierung mit Gewinde DIN 332, Blatt 2

KT675.04  
KT676.04

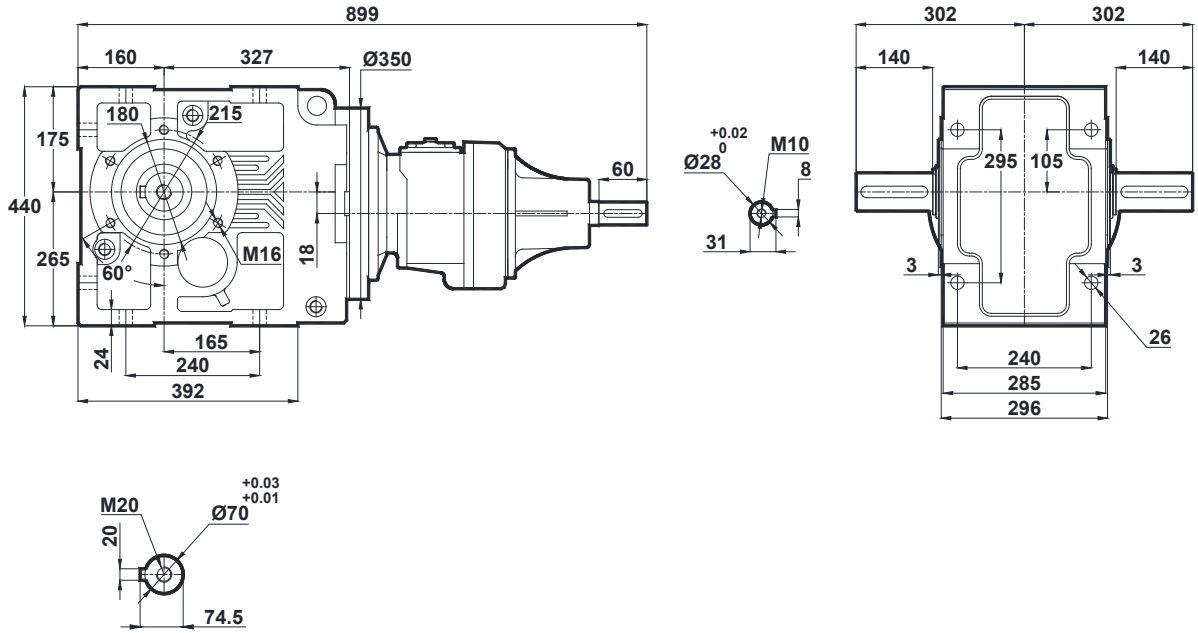

KT675.05  
KT676.05

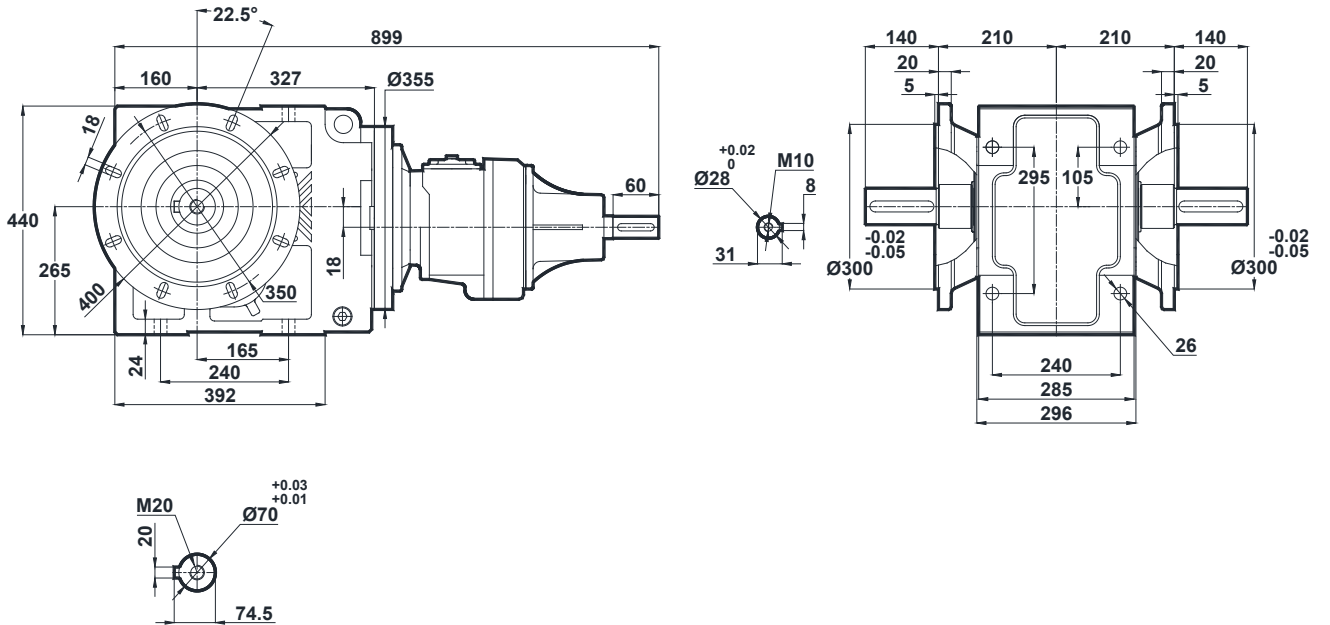





# Ölçü Sayfaları Dimension Pages Abmessungenseiten



-Mil ucu çekirme deliği DIN 332 sayfa 2 / Tapped center hole to DIN 332, sheet 2 / Zentrierung mit Gewinde DIN 332, Blatt 2

KT675.08  
KT676.08

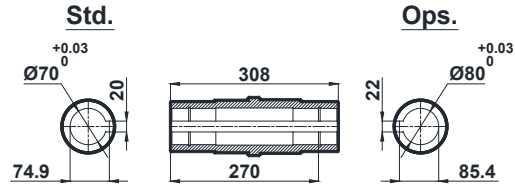
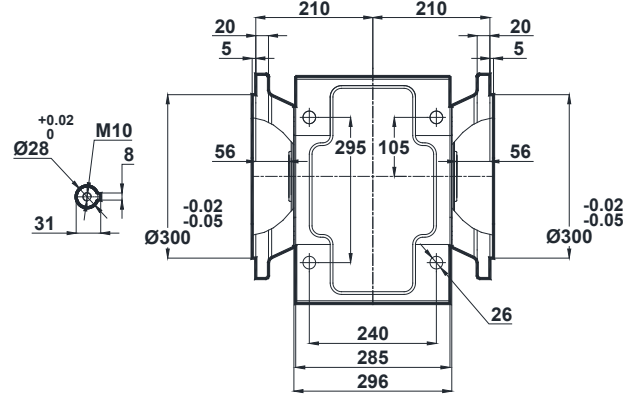
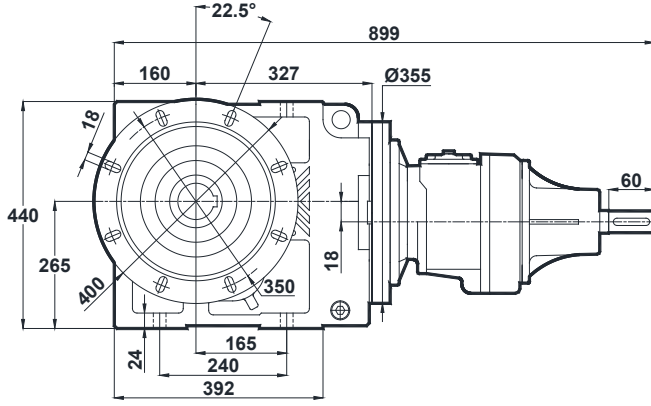



# Ölçü Sayfaları

## Dimension Pages

### Abmessungsseiten

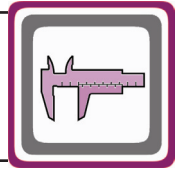

-Mil ucu çektirme deliği DIN 332 sayfa 2 / Tapped center hole to DIN 332, sheet 2 / Zentrierung mit Gewinde DIN 332, Blatt 2

KT773.00

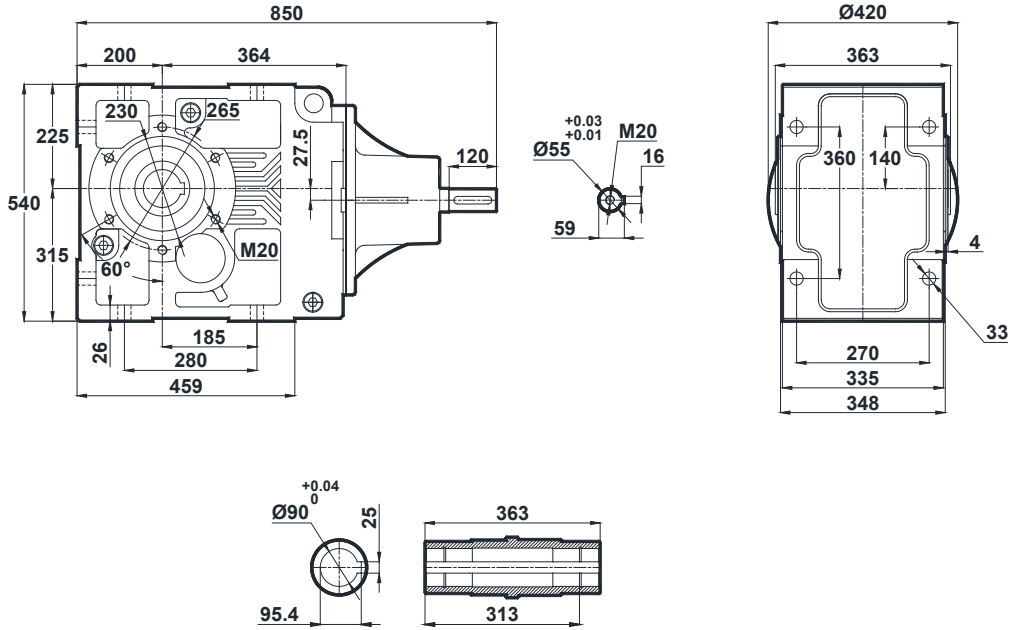

KT773.01

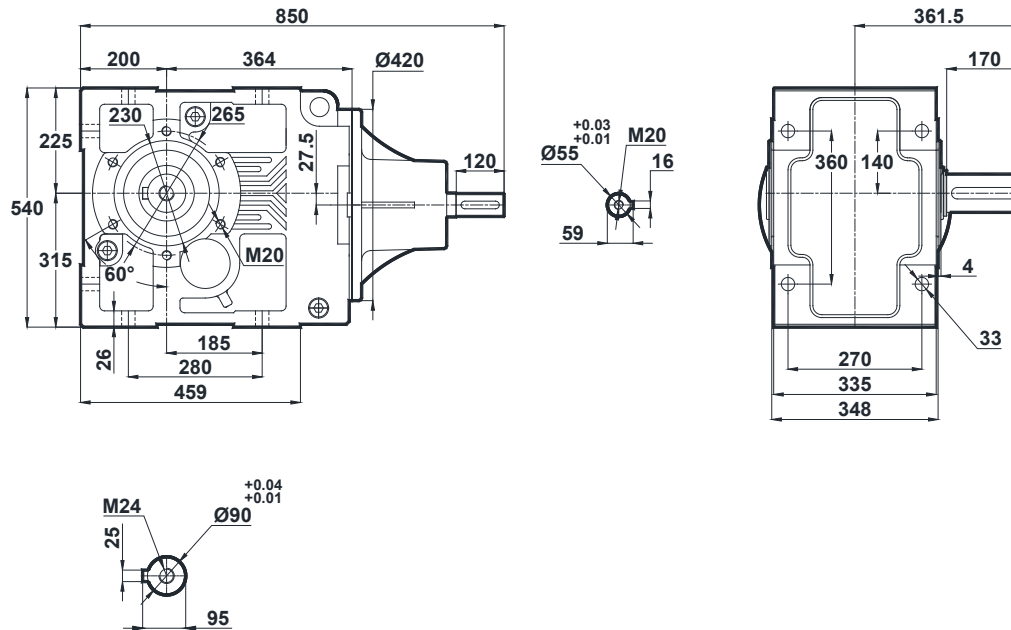



# Ölçü Sayfaları

## Dimension Pages

### Abmessungsseiten

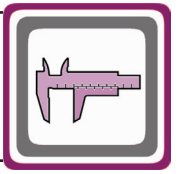

-Mil ucu çektirme deliği DIN 332 sayfa 2 / Tapped center hole to DIN 332, sheet 2 / Zentrierung mit Gewinde DIN 332, Blatt 2

KT773.02

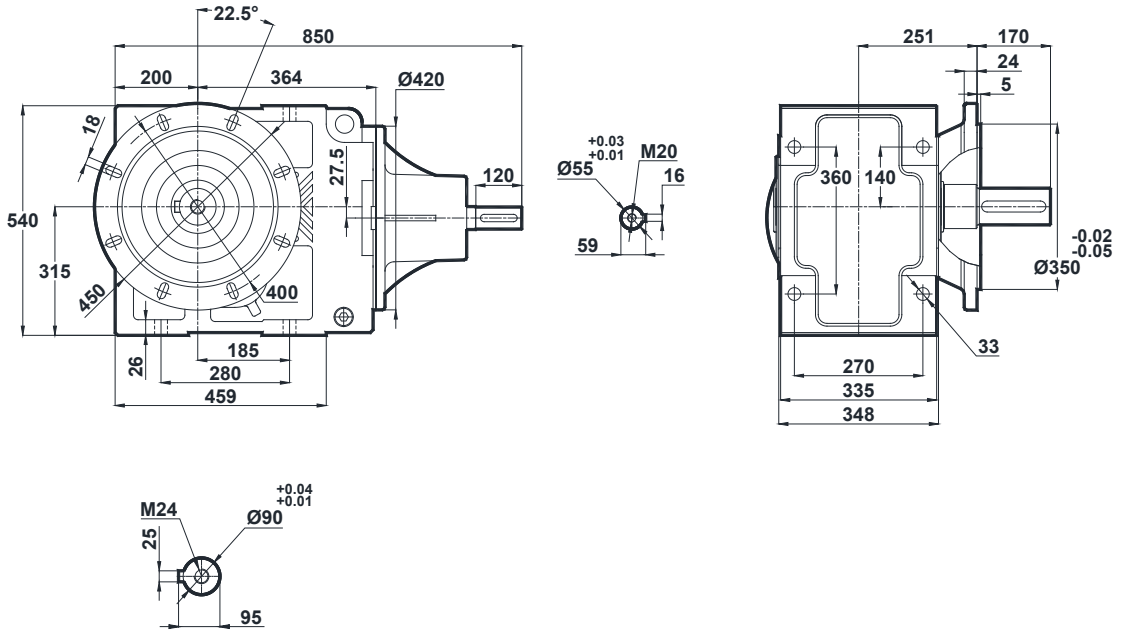

KT773.03

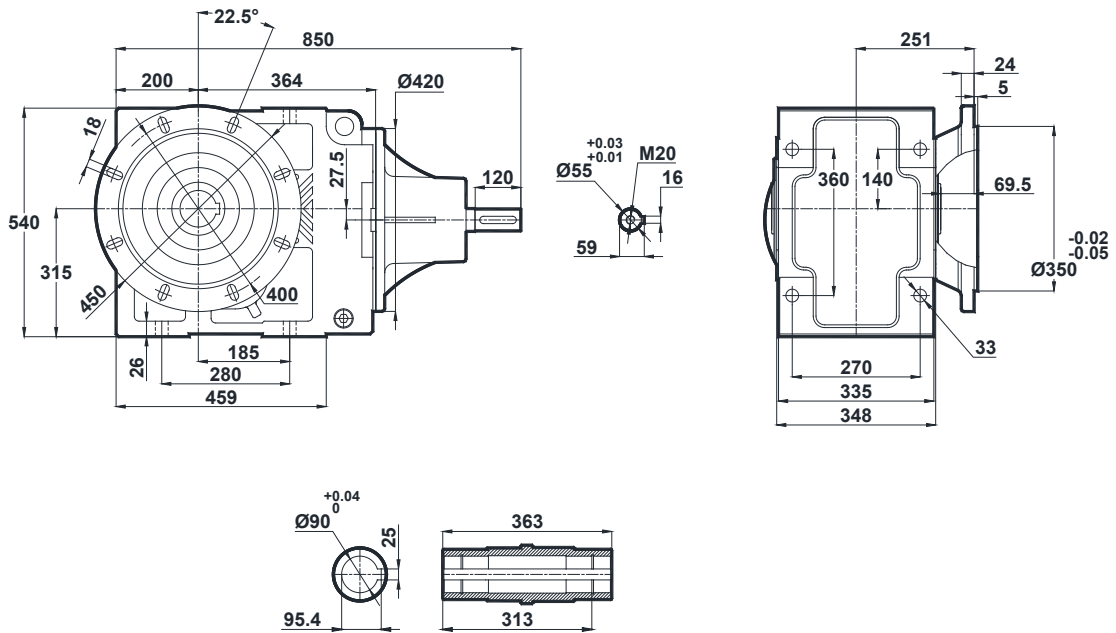

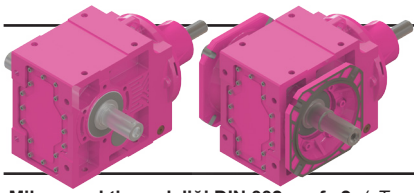

# Ölçü Sayfaları

## Dimension Pages

### Abmessungsseiten

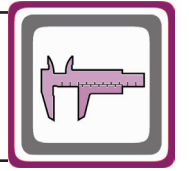

-Mil ucu çekirme deliği DIN 332 sayfa 2 / Tapped center hole to DIN 332, sheet 2 / Zentrierung mit Gewinde DIN 332, Blatt 2

KT773.04

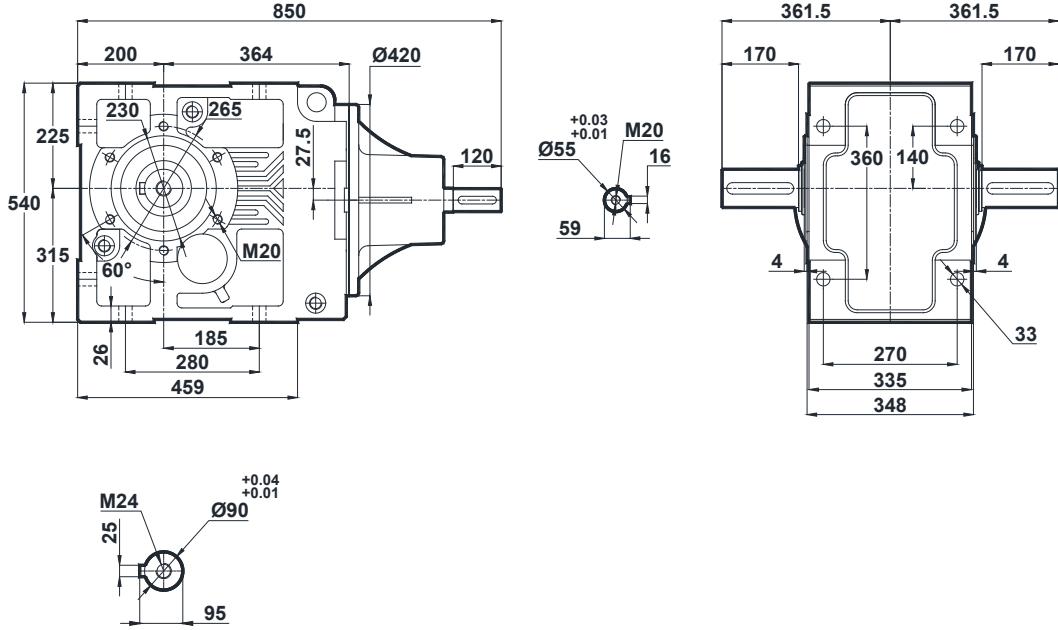

KT773.05

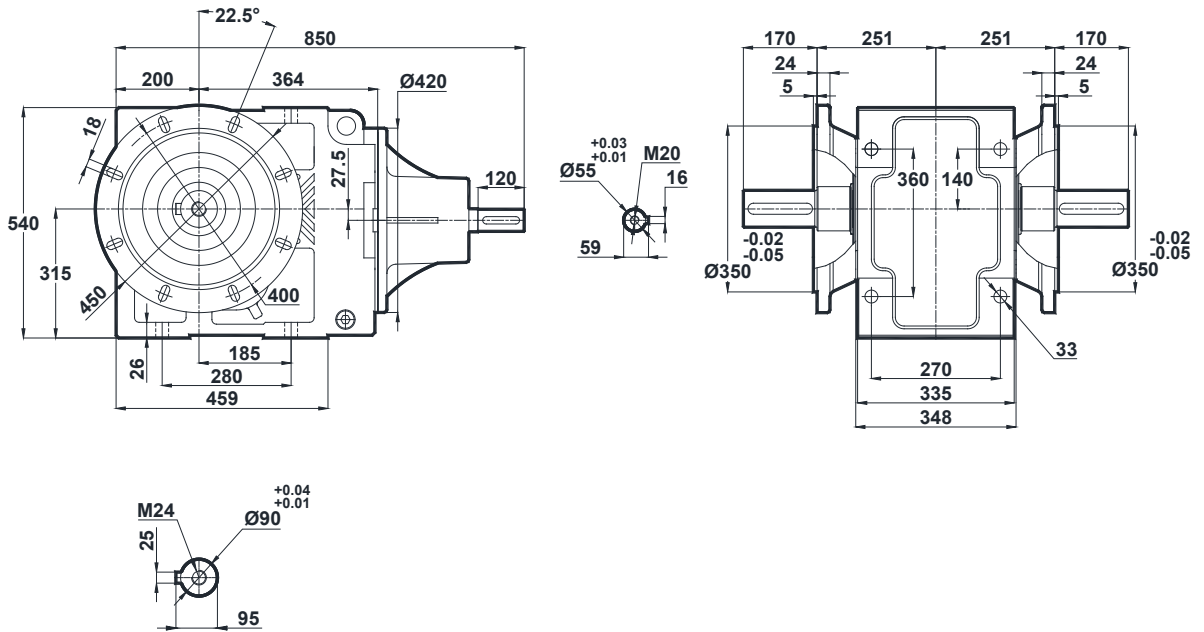



# Ölçü Sayfaları

## Dimension Pages

### Abmessungsseiten



-Mil ucu çektirme deliği DIN 332 sayfa 2 / Tapped center hole to DIN 332, sheet 2 / Zentrierung mit Gewinde DIN 332, Blatt 2

KT773.08

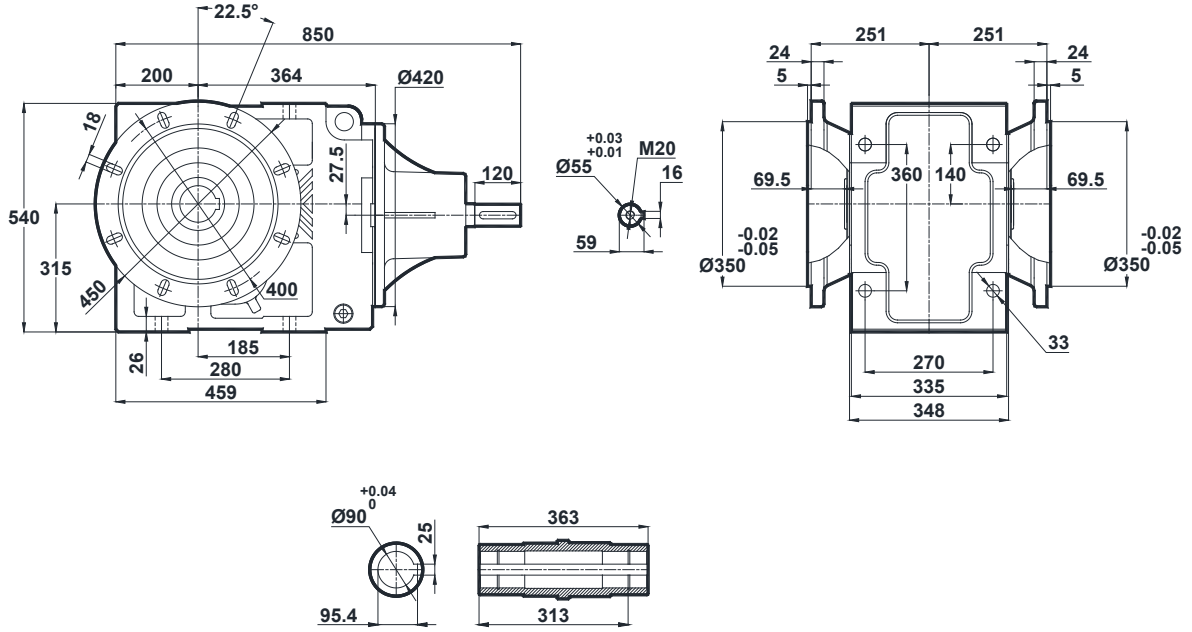



# Ölçü Sayfaları

## Dimension Pages

### Abmessungsseiten

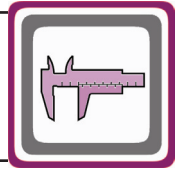

-Mil ucu çekirme deliği DIN 332 sayfa 2 / Tapped center hole to DIN 332, sheet 2 / Zentrierung mit Gewinde DIN 332, Blatt 2

KT774.00

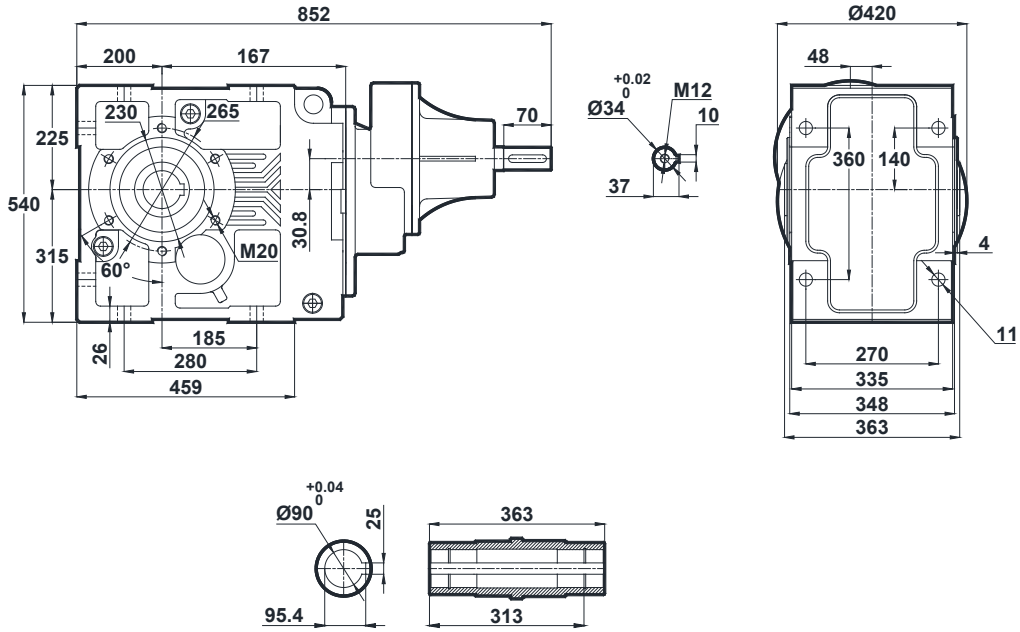

KT774.01

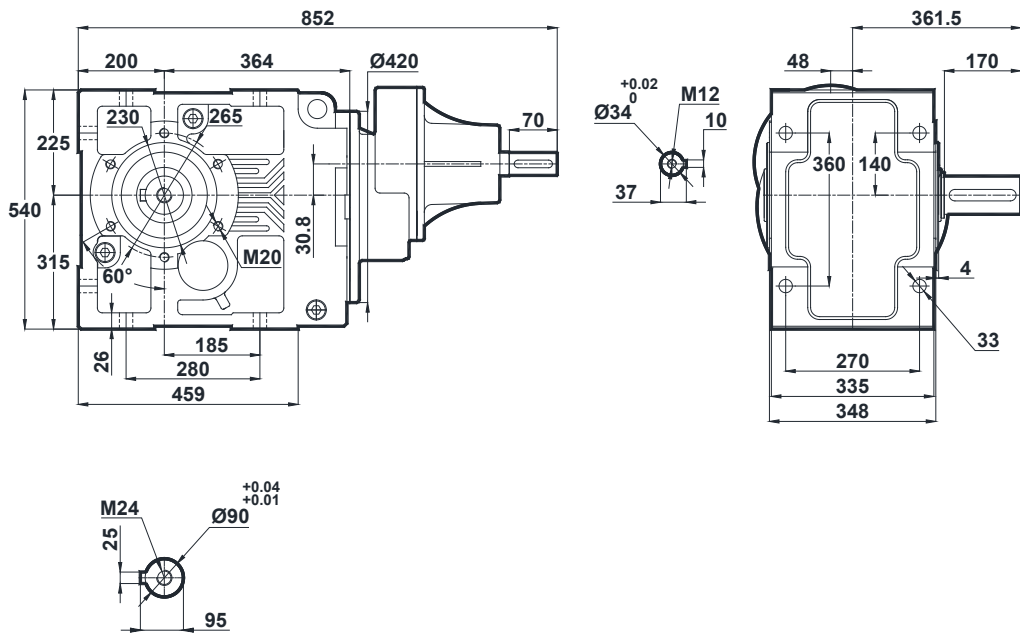



# Ölçü Sayfaları

## Dimension Pages

### Abmessungsseiten



-Mil ucu çekirme deliği DIN 332 sayfa 2 / Tapped center hole to DIN 332, sheet 2 / Zentrierung mit Gewinde DIN 332, Blatt 2

KT774.02

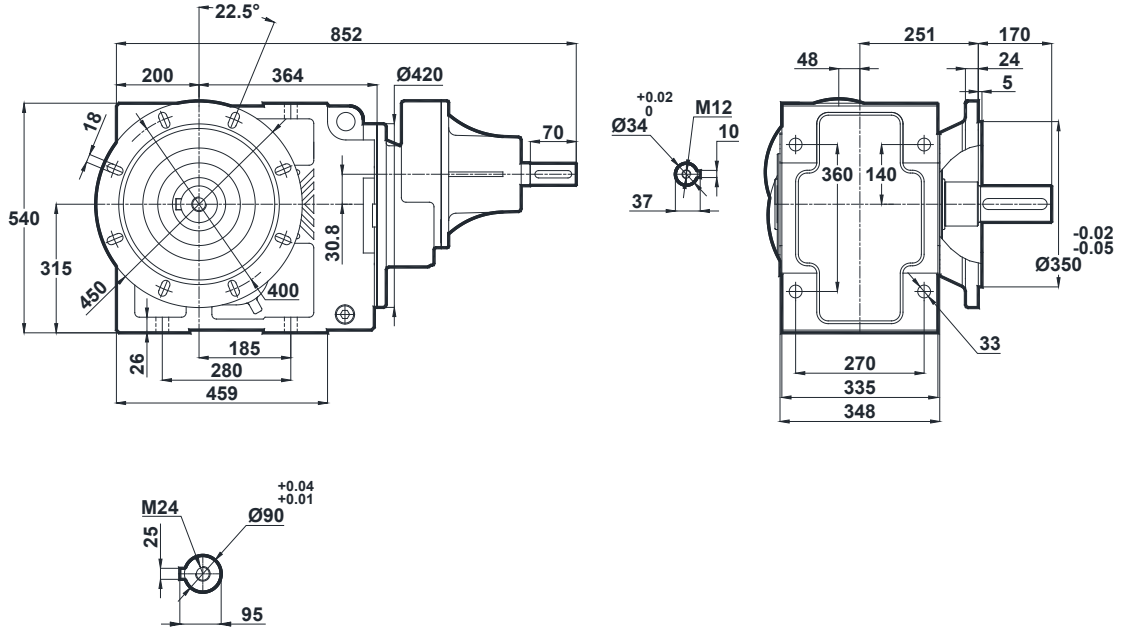

KT774.03

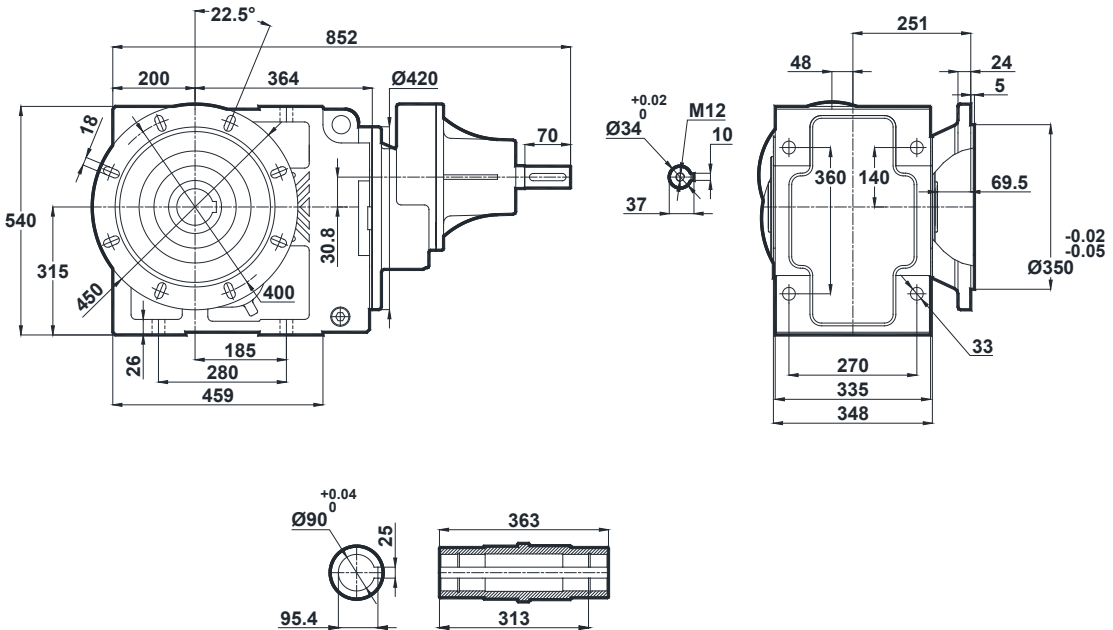

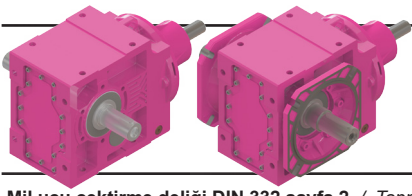

# Ölçü Sayfaları

## Dimension Pages

### Abmessungsseiten

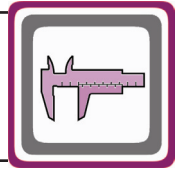

-Mil ucu çekirme deliği DIN 332 sayfa 2 / Tapped center hole to DIN 332, sheet 2 / Zentrierung mit Gewinde DIN 332, Blatt 2

#### KT774.04

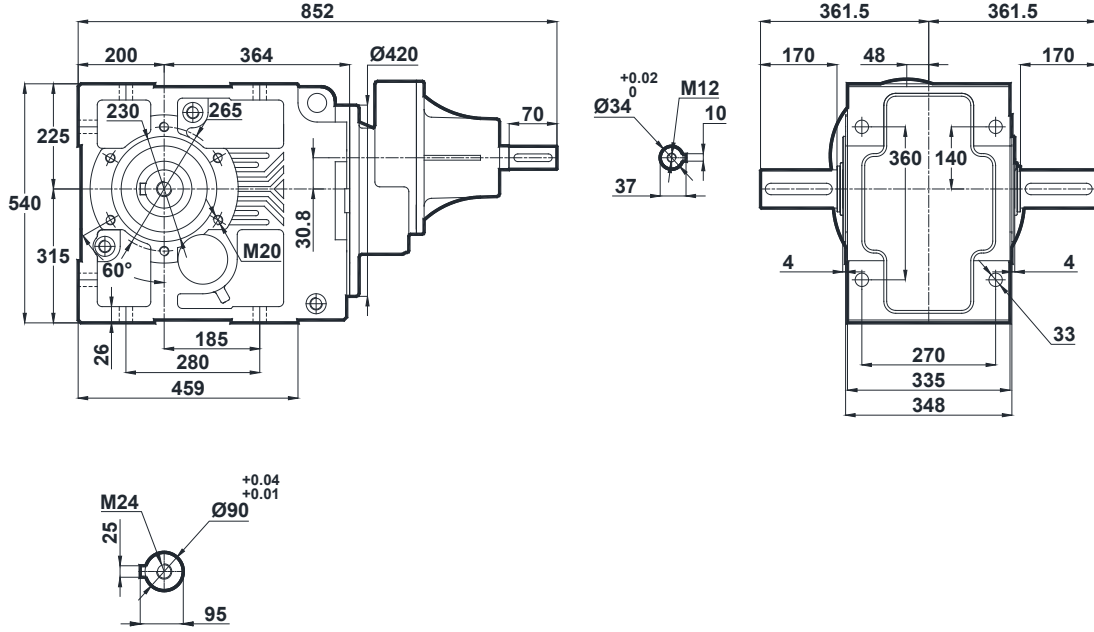

#### KT774.05

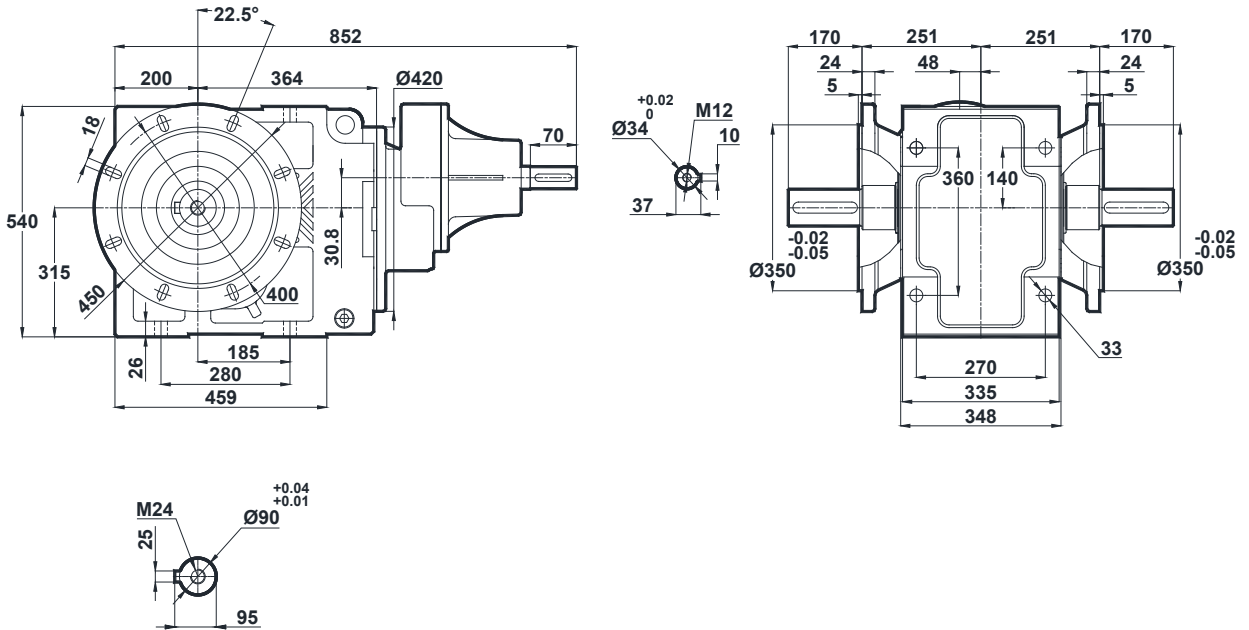





# Ölçü Sayfaları

## Dimension Pages

### Abmessungsseiten



-Mil ucu çektirme deliği DIN 332 sayfa 2 / Tapped center hole to DIN 332, sheet 2 / Zentrierung mit Gewinde DIN 332, Blatt 2

KT774.08

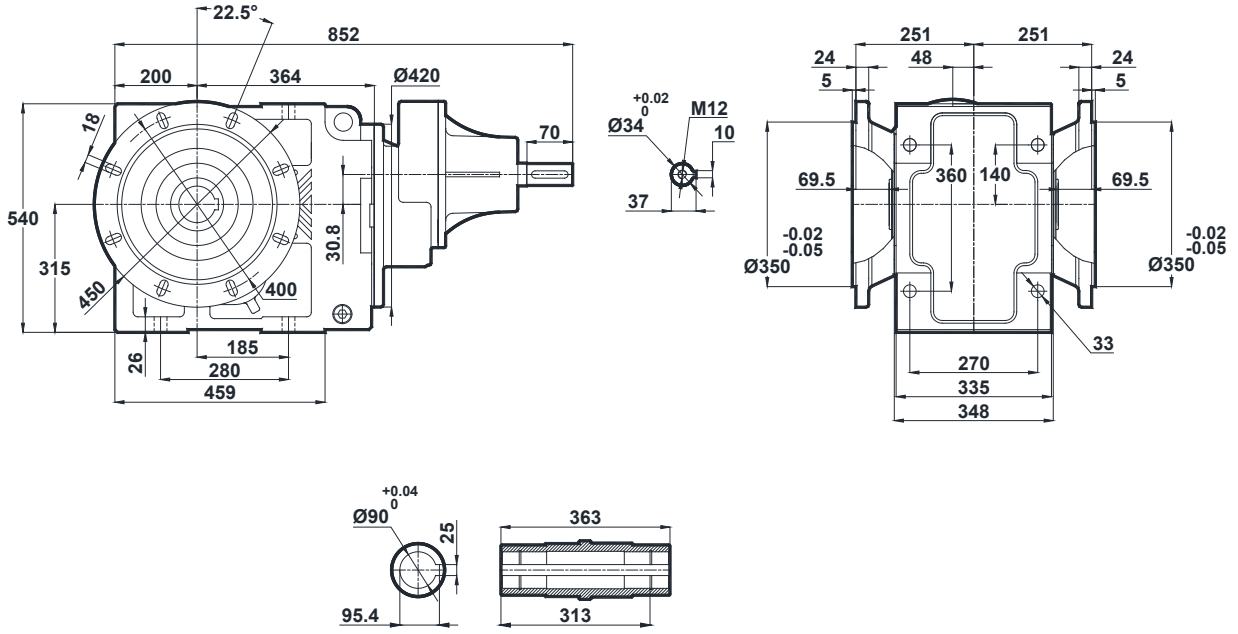

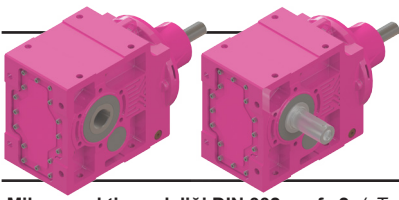

# Ölçü Sayfaları

## Dimension Pages

### Abmessungsseiten

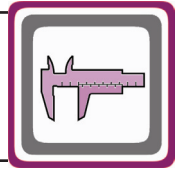

-Mil ucu çekirme deliği DIN 332 sayfa 2 / Tapped center hole to DIN 332, sheet 2 / Zentrierung mit Gewinde DIN 332, Blatt 2

KT775.00  
KT776.00

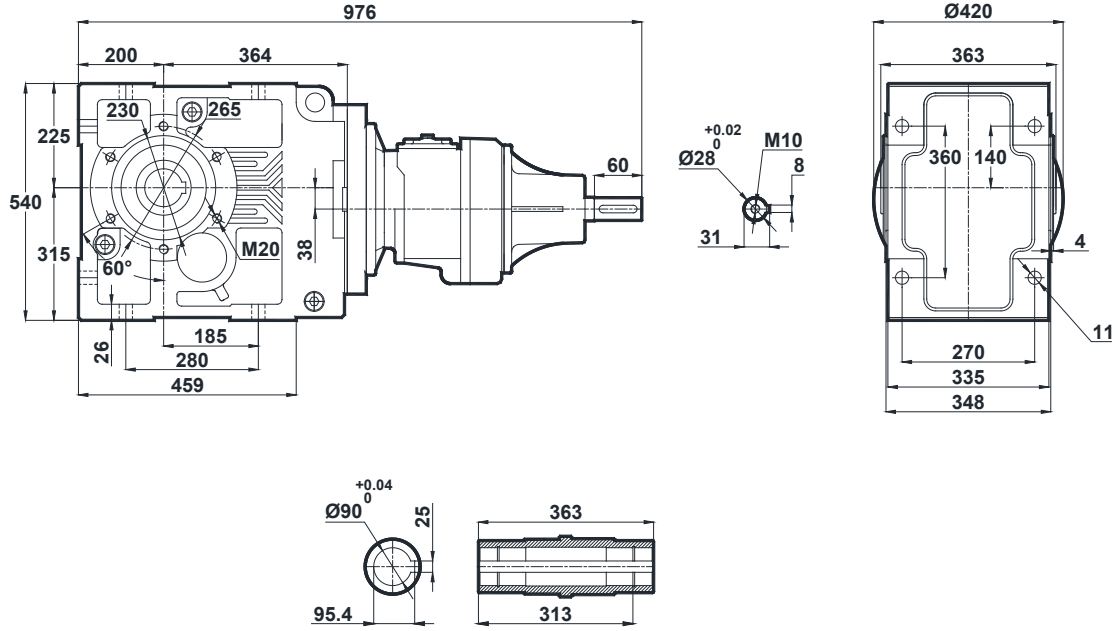

KT775.01  
KT776.01

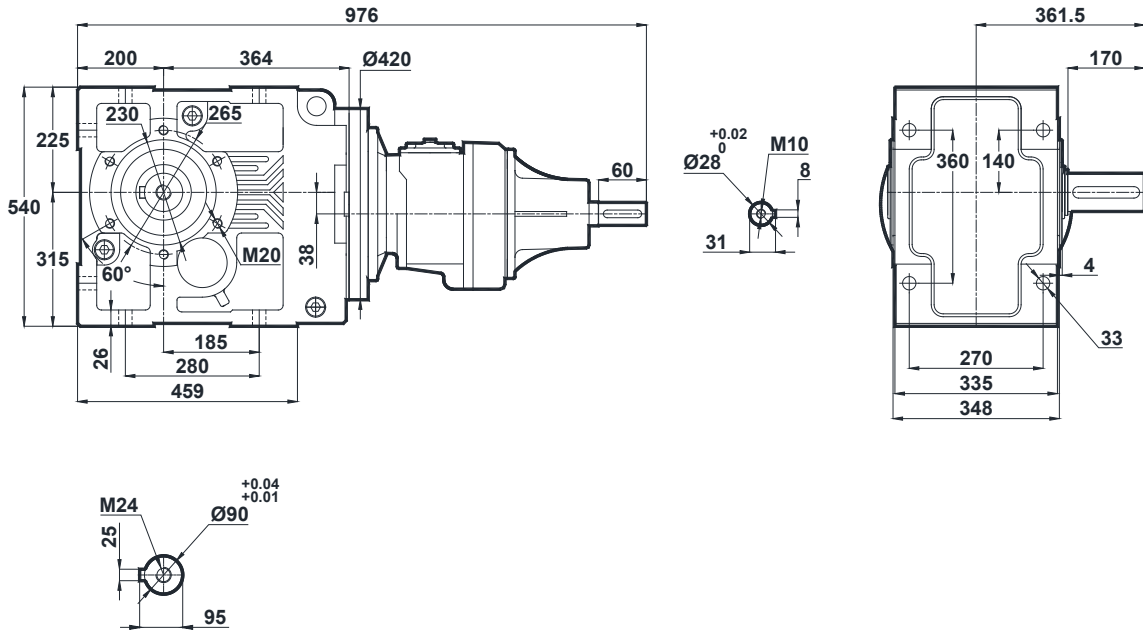

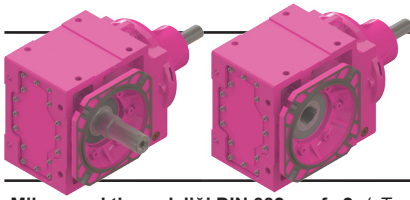

# Ölçü Sayfaları

## Dimension Pages

### Abmessungsseiten



-Mil ucu çekirme deliği DIN 332 sayfa 2 / Tapped center hole to DIN 332, sheet 2 / Zentrierung mit Gewinde DIN 332, Blatt 2

KT775.02  
KT776.02

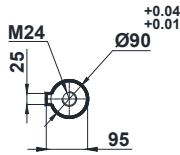
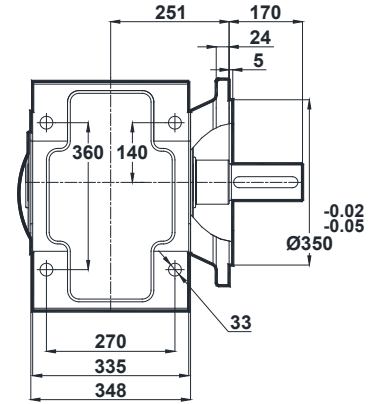
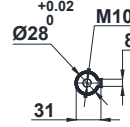
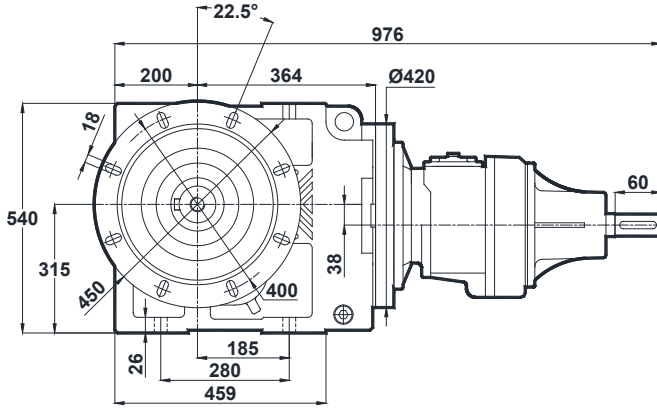

KT775.03  
KT776.03

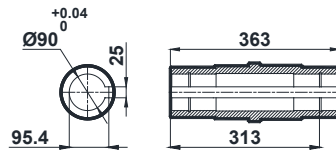
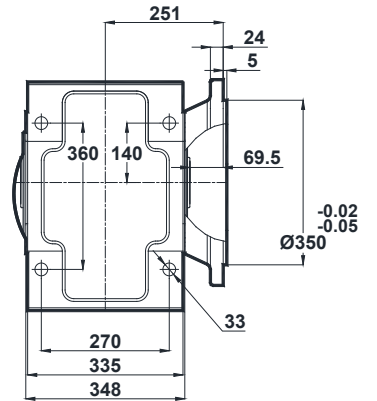
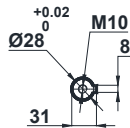
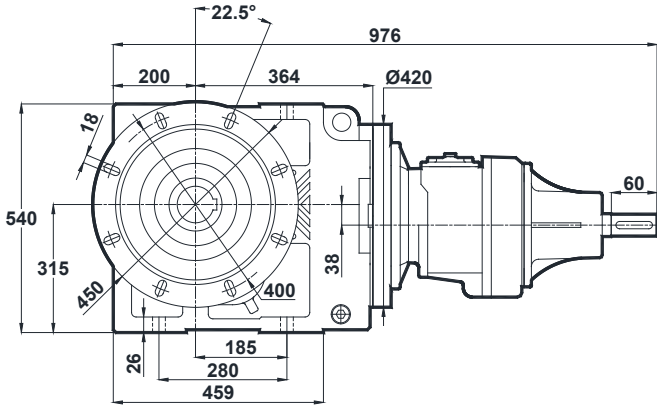

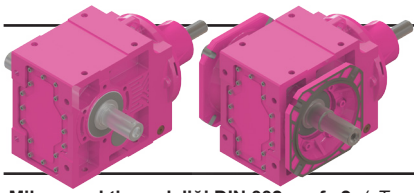

# Ölçü Sayfaları

## Dimension Pages

### Abmessungsseiten

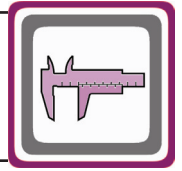

-Mil ucu çektirme deliği DIN 332 sayfa 2 / Tapped center hole to DIN 332, sheet 2 / Zentrierung mit Gewinde DIN 332, Blatt 2

KT775.04  
KT776.04

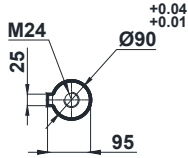
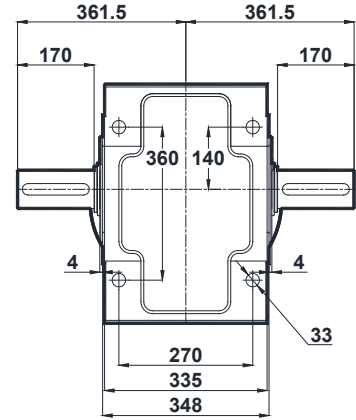
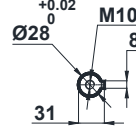
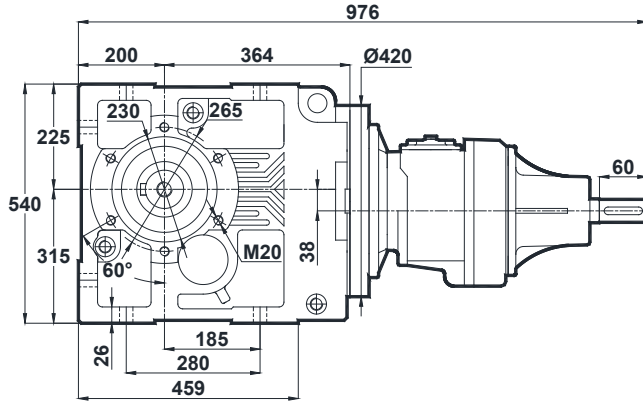

KT775.05  
KT776.05

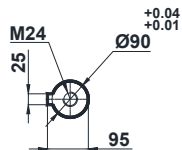
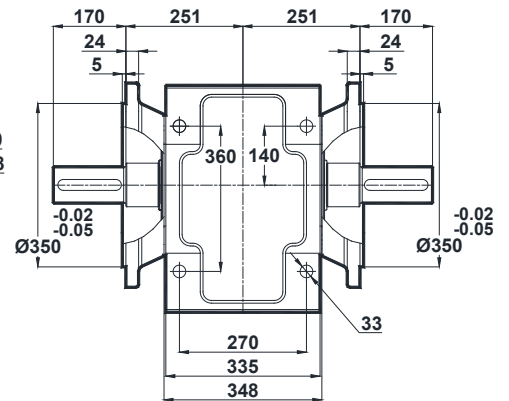
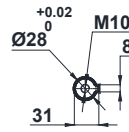
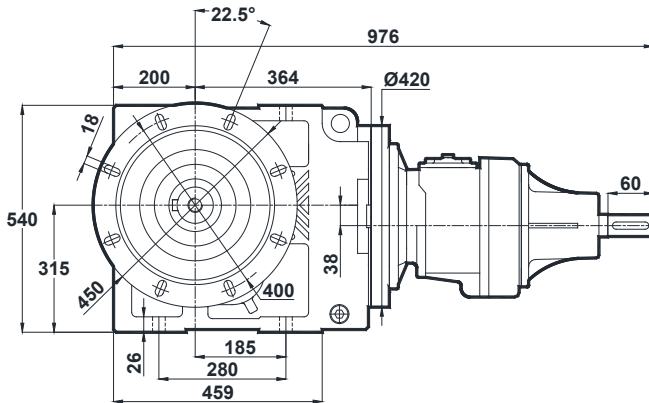



# Ölçü Sayfaları Dimension Pages Abmessungsseiten



-Mil ucu çektirme deliği DIN 332 sayfa 2 / Tapped center hole to DIN 332, sheet 2 / Zentrierung mit Gewinde DIN 332, Blatt 2

KT775.08  
KT776.08

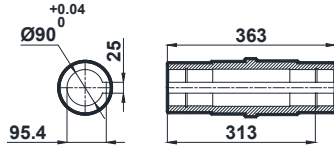
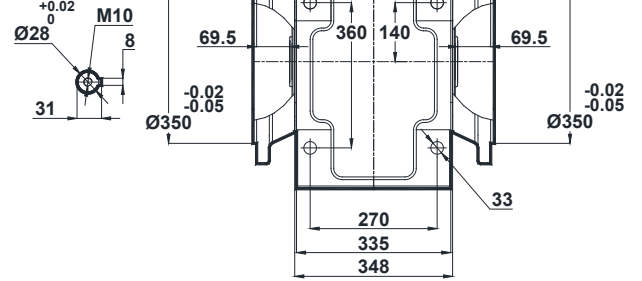
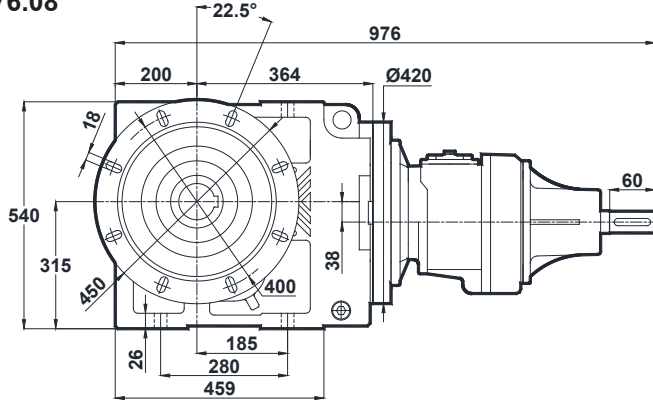



# Ölçü Sayfaları

## Dimension Pages

### Abmessungsseiten

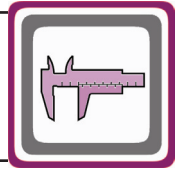

-Mil ucu çektirme deliği DIN 332 sayfa 2 / Tapped center hole to DIN 332, sheet 2 / Zentrierung mit Gewinde DIN 332, Blatt 2

#### KT873.00

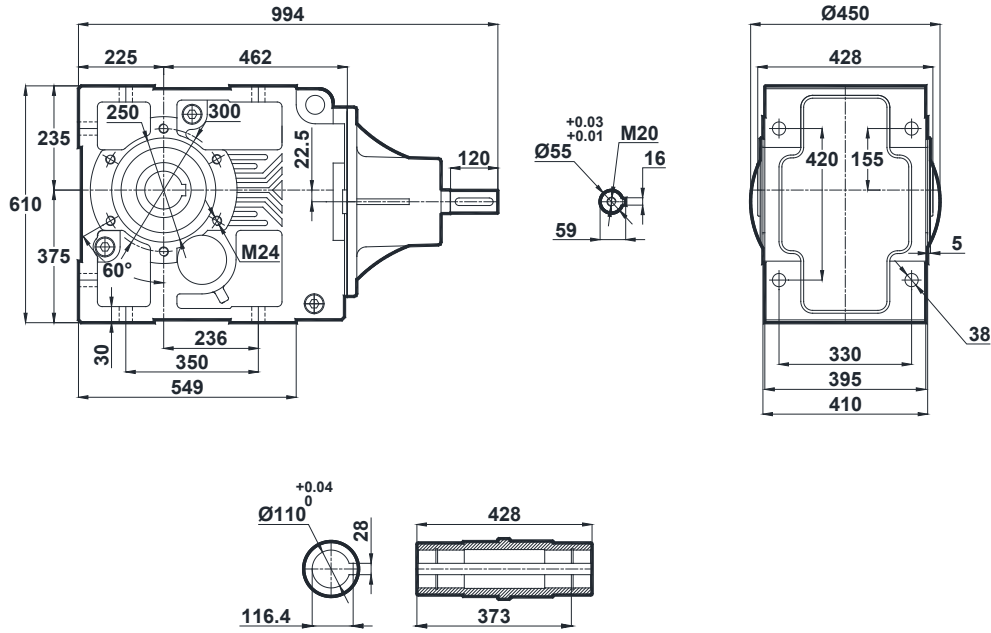

#### KT873.01

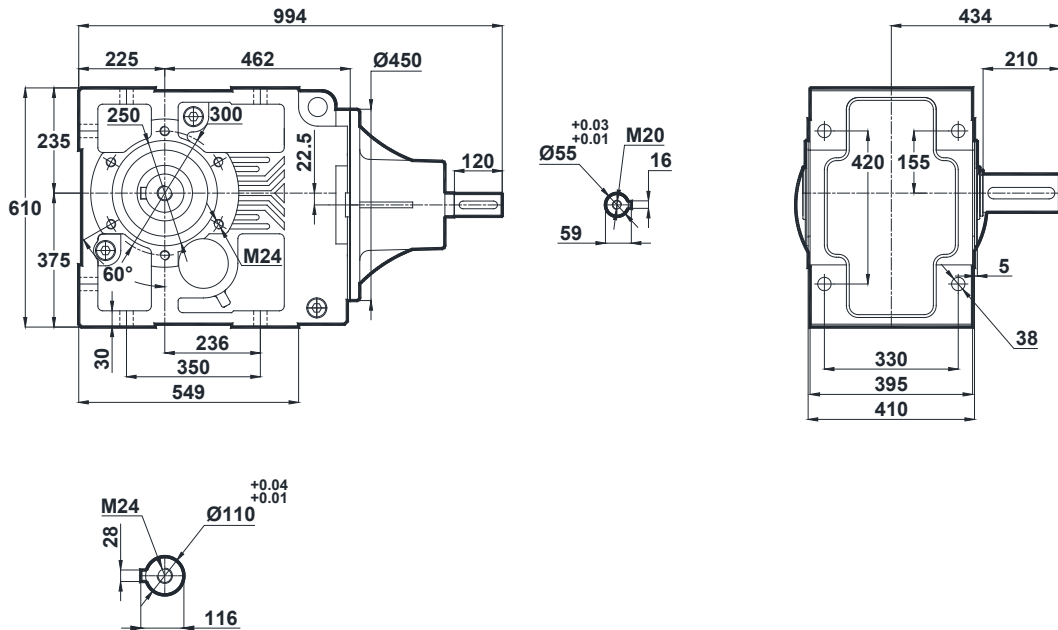



# Ölçü Sayfaları

## Dimension Pages

### Abmessungsseiten



-Mil ucu çekirme deliği DIN 332 sayfa 2 / Tapped center hole to DIN 332, sheet 2 / Zentrierung mit Gewinde DIN 332, Blatt 2

KT873.02

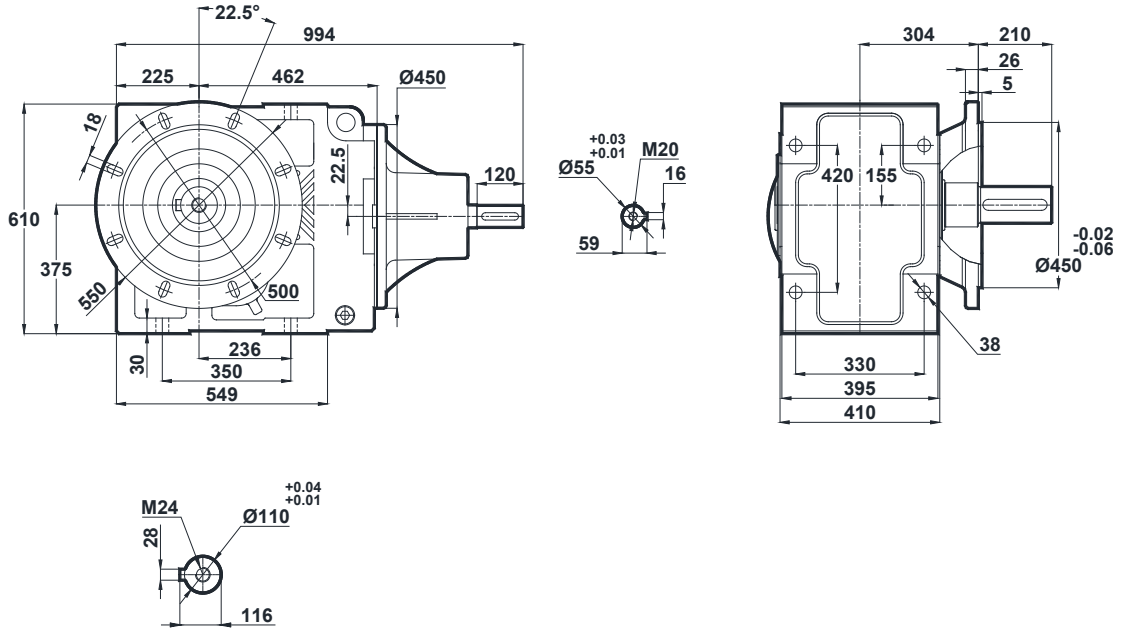

KT873.03

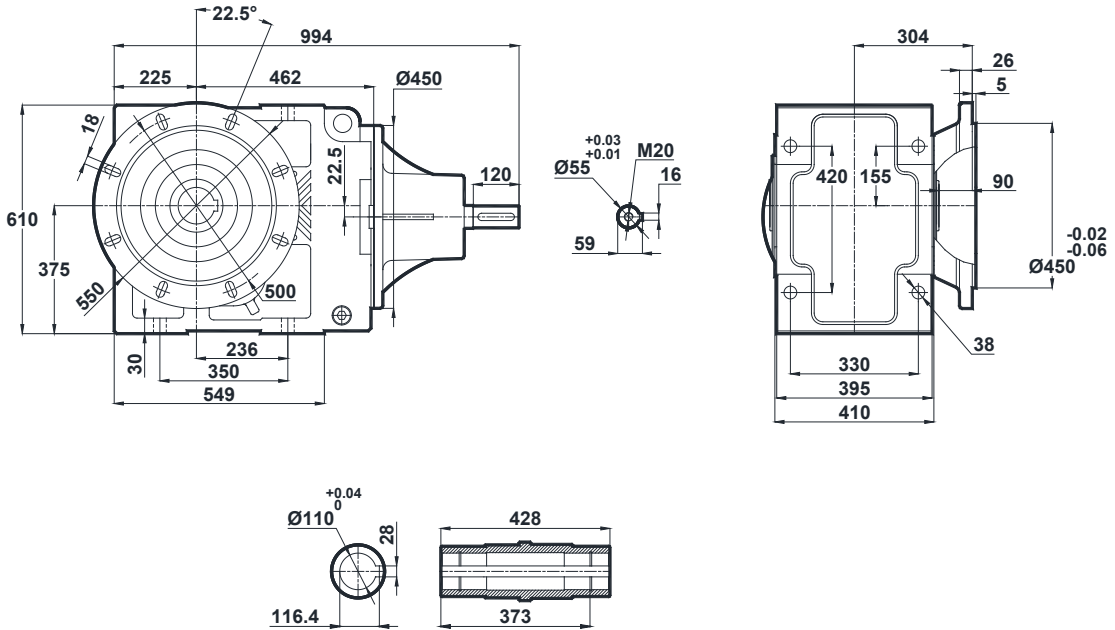

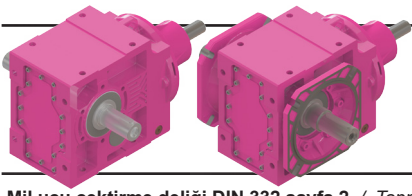

# Ölçü Sayfaları

## Dimension Pages

### Abmessungsseiten

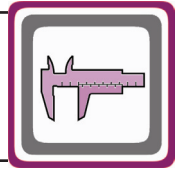

-Mil ucu çekirme deliği DIN 332 sayfa 2 / Tapped center hole to DIN 332, sheet 2 / Zentrierung mit Gewinde DIN 332, Blatt 2

#### KT873.04

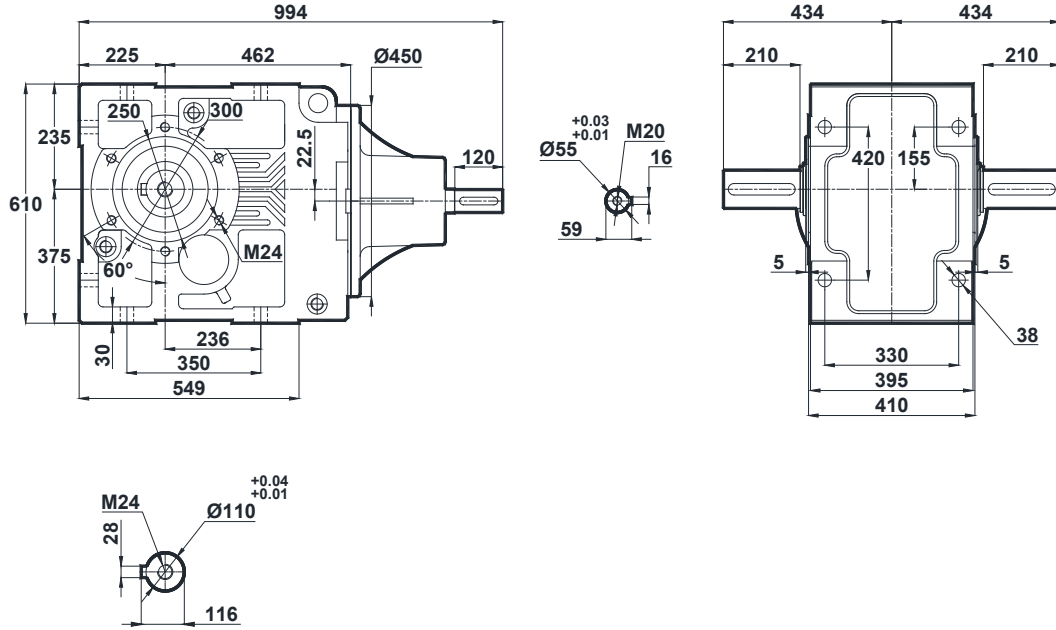

#### KT873.05

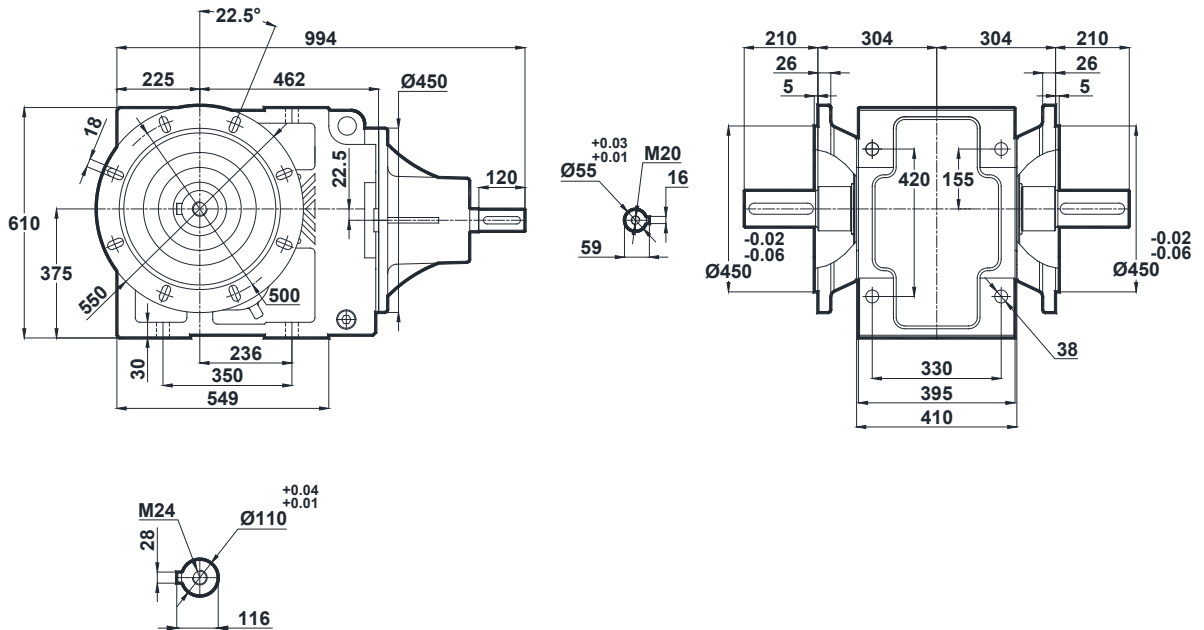





# Ölçü Sayfaları

## Dimension Pages

### Abmessungsseiten



-Mil ucu çekirme deliği DIN 332 sayfa 2 / Tapped center hole to DIN 332, sheet 2 / Zentrierung mit Gewinde DIN 332, Blatt 2

KT873.08

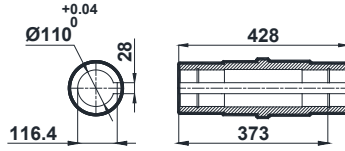
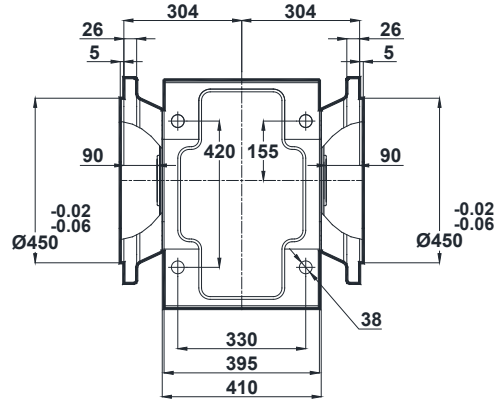
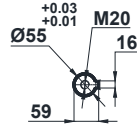
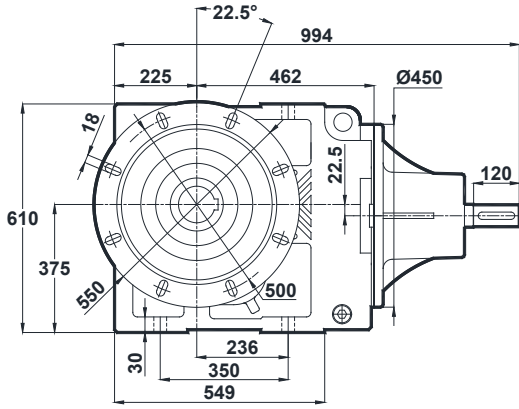

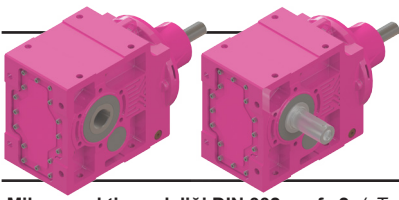

# Ölçü Sayfaları

## Dimension Pages

### Abmessungsseiten

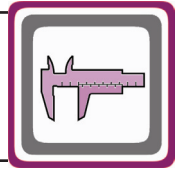

-Mil ucu çekirme deliği DIN 332 sayfa 2 / Tapped center hole to DIN 332, sheet 2 / Zentrierung mit Gewinde DIN 332, Blatt 2

KT874.00

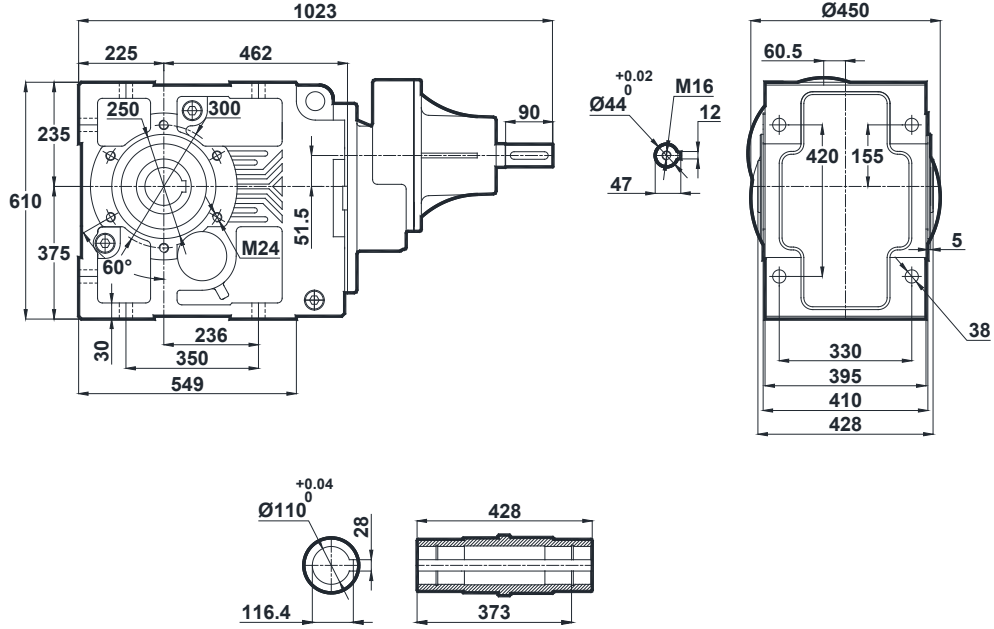

KT874.01

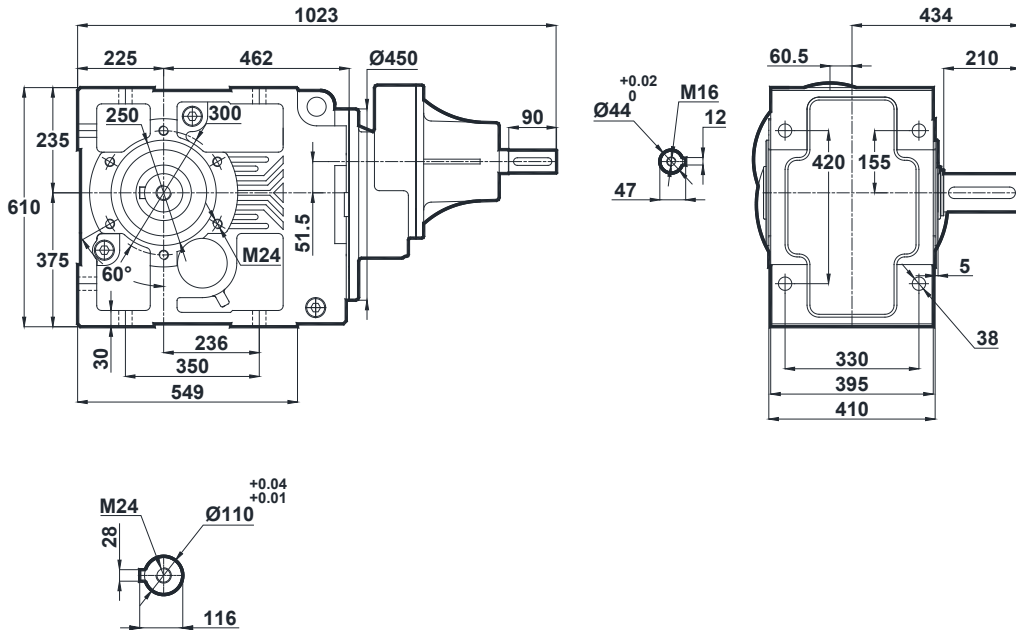



# Ölçü Sayfaları

## Dimension Pages

### Abmessungsseiten

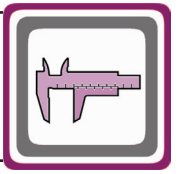

-Mil ucu çekirme deliği DIN 332 sayfa 2 / Tapped center hole to DIN 332, sheet 2 / Zentrierung mit Gewinde DIN 332, Blatt 2

KT874.02

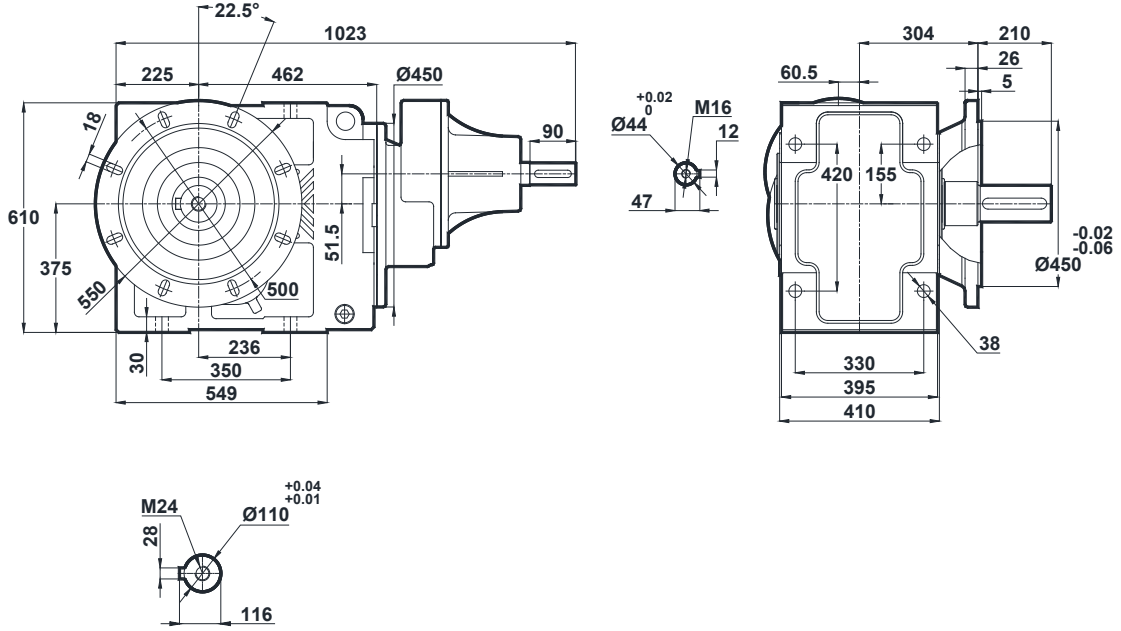

KT874.03

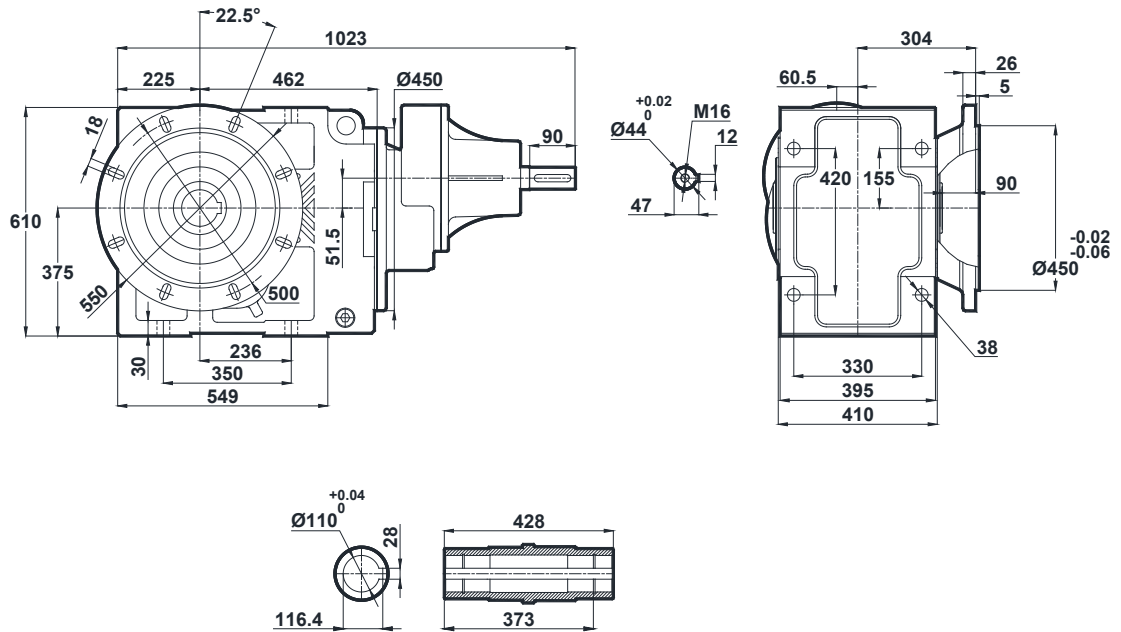

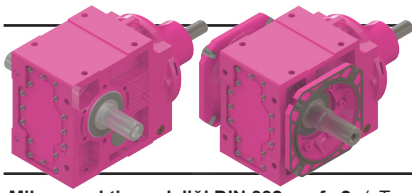

# Ölçü Sayfaları Dimension Pages Abmessungenseiten

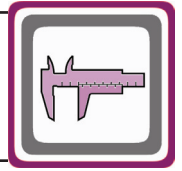

-Mil ucu çektirme deliği DIN 332 sayfa 2 / Tapped center hole to DIN 332, sheet 2 / Zentrierung mit Gewinde DIN 332, Blatt 2

## KT874.04

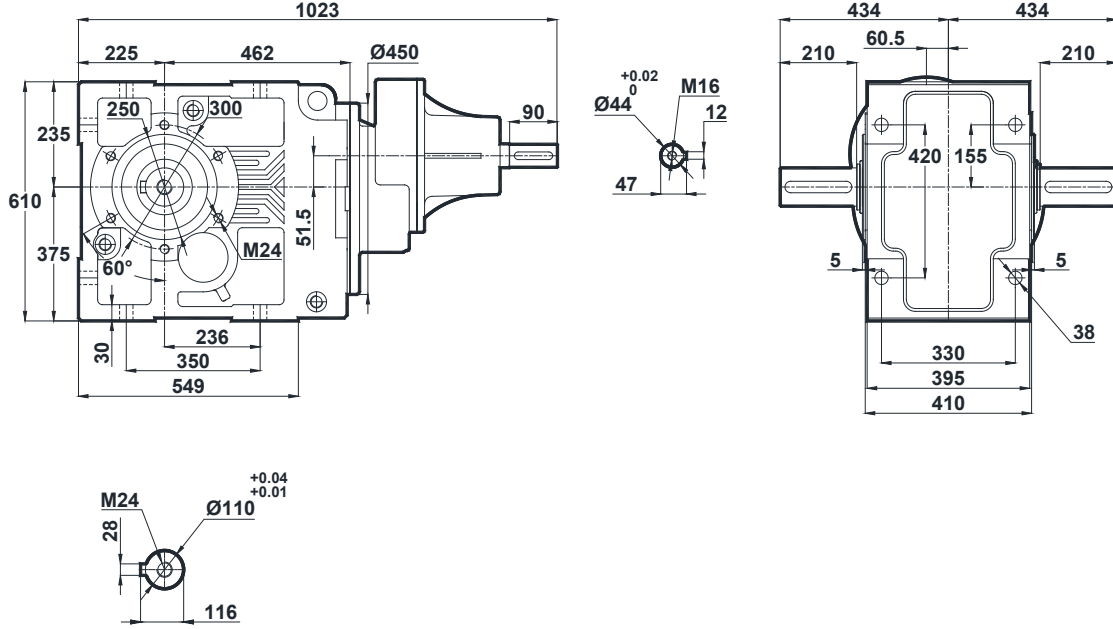

## KT874.05

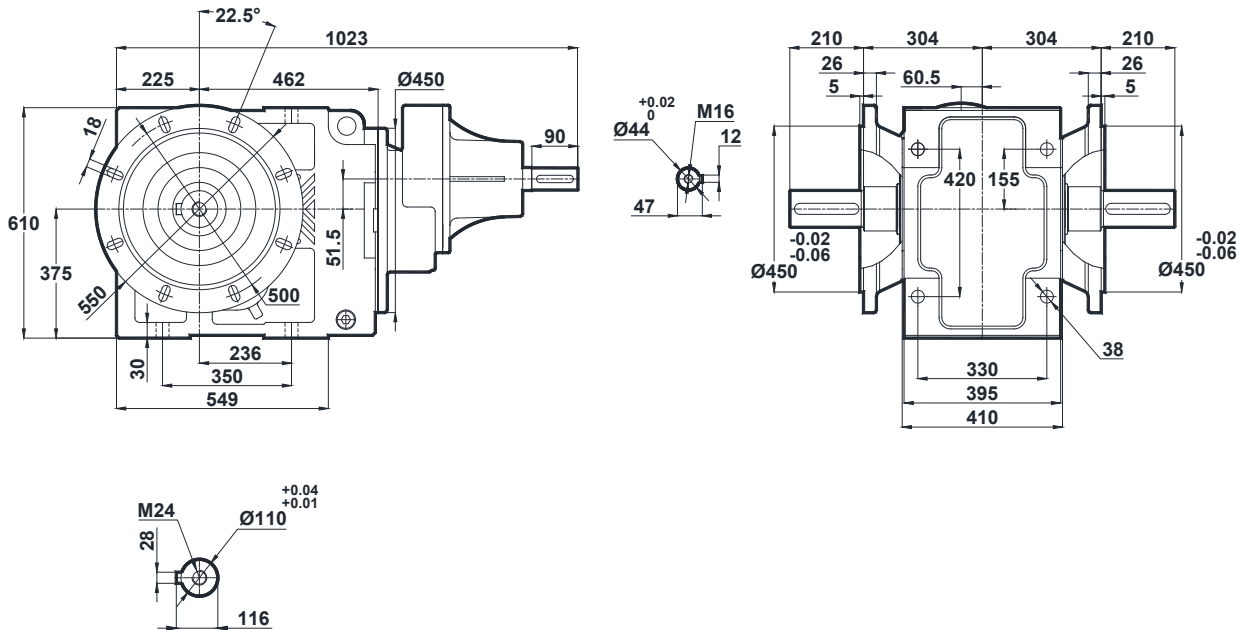



# Ölçü Sayfaları

## Dimension Pages

### Abmessungsseiten



-Mil ucu çekirme deliği DIN 332 sayfa 2 / Tapped center hole to DIN 332, sheet 2 / Zentrierung mit Gewinde DIN 332, Blatt 2

KT874.08

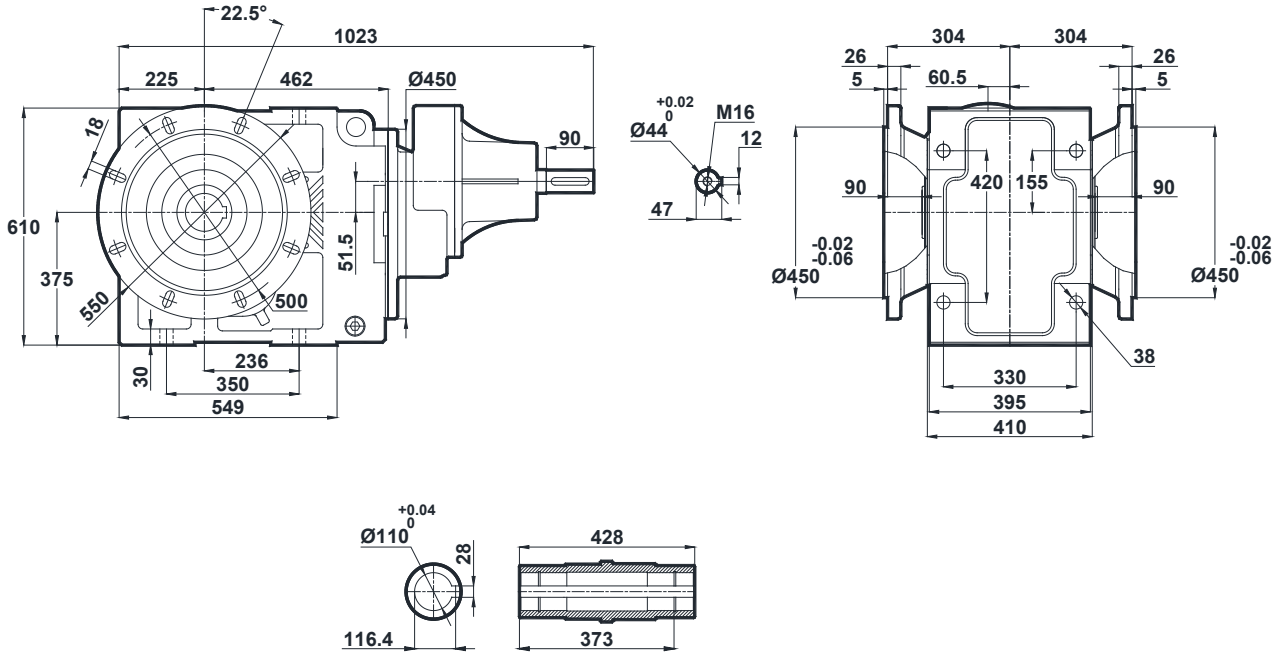



# Ölçü Sayfaları

## Dimension Pages

### Abmessungsseiten

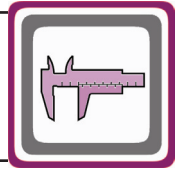

-Mil ucu çekirme deliği DIN 332 sayfa 2 / Tapped center hole to DIN 332, sheet 2 / Zentrierung mit Gewinde DIN 332, Blatt 2

KT875.00  
KT876.00

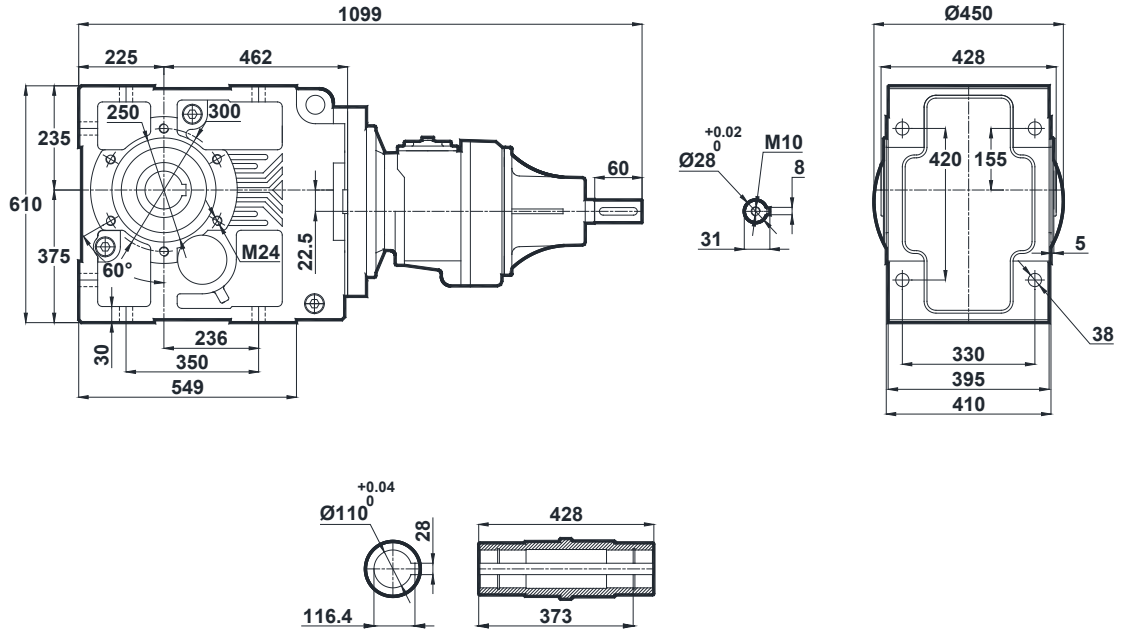

KT875.01  
KT876.01

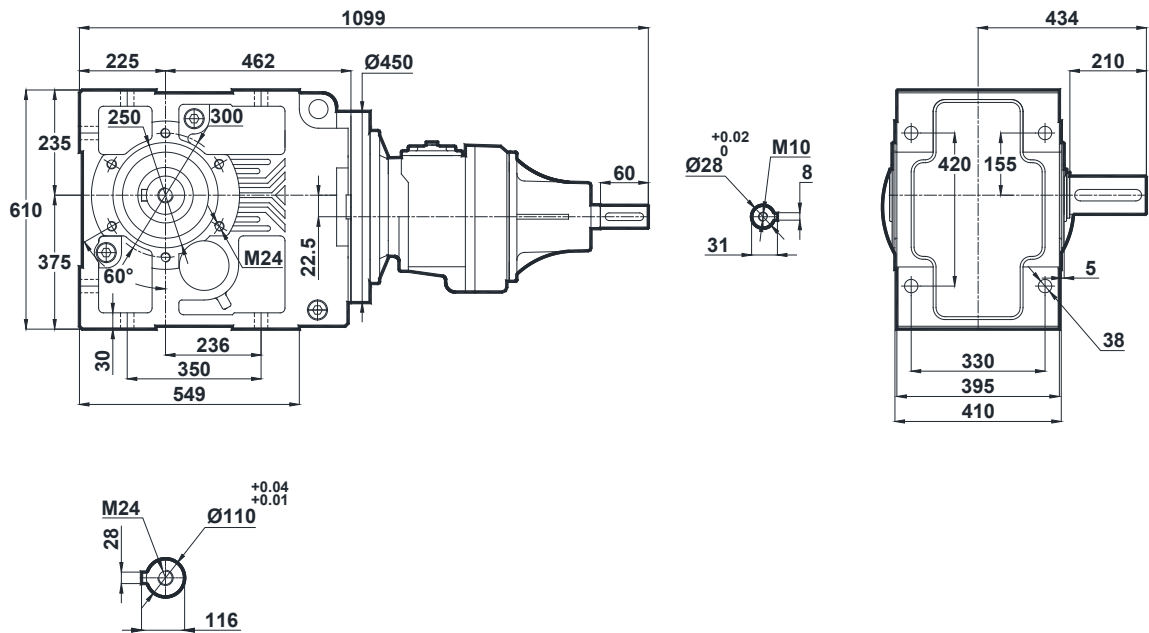

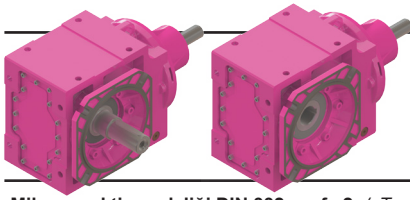

# Ölçü Sayfaları

## Dimension Pages

### Abmessungsseiten



-Mil ucu çekirme deliği DIN 332 sayfa 2 / Tapped center hole to DIN 332, sheet 2 / Zentrierung mit Gewinde DIN 332, Blatt 2

KT875.02  
KT876.02

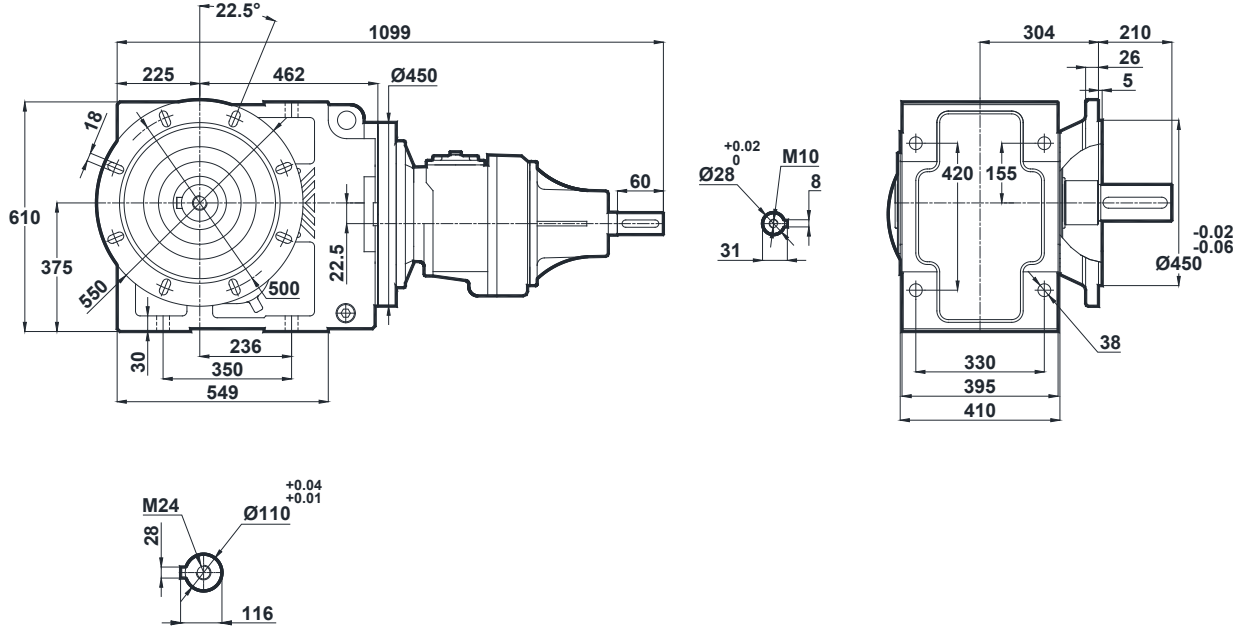

KT875.03  
KT876.03

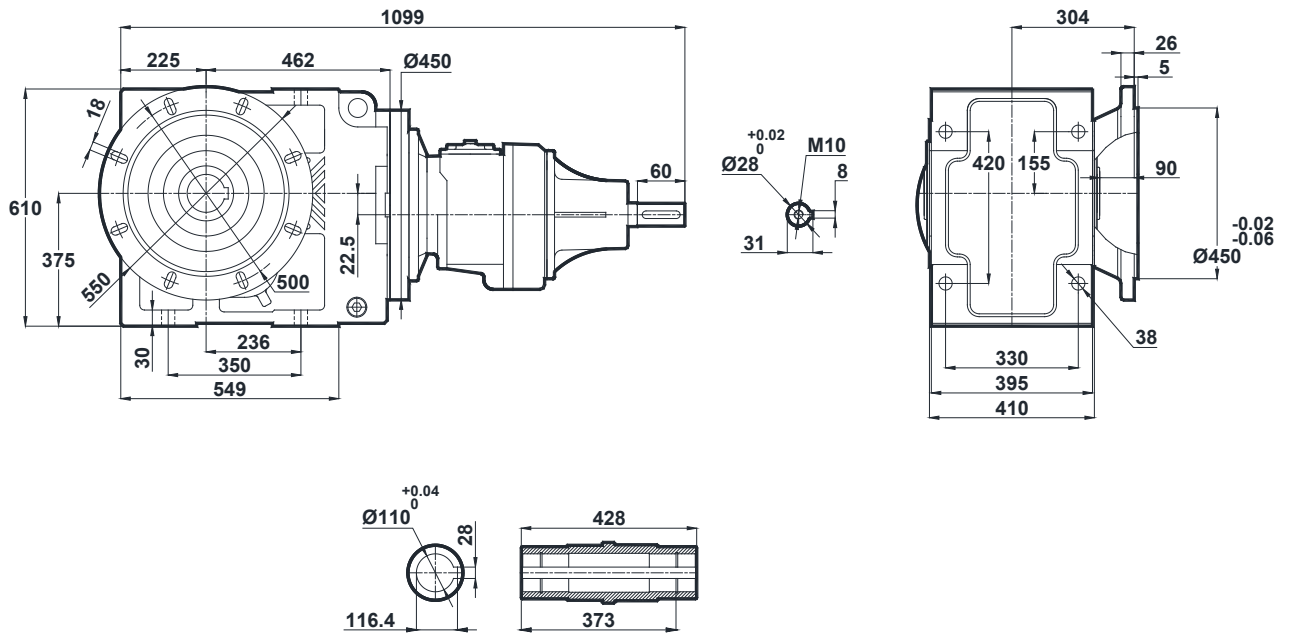

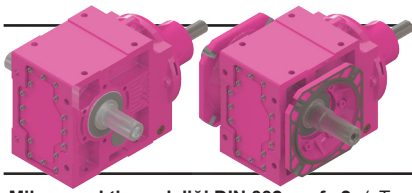

# Ölçü Sayfaları

## Dimension Pages

### Abmessungsseiten

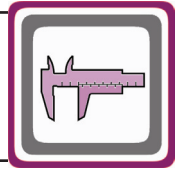

-Mil ucu çekirme deliği DIN 332 sayfa 2 / Tapped center hole to DIN 332, sheet 2 / Zentrierung mit Gewinde DIN 332, Blatt 2

KT875.04  
KT876.04

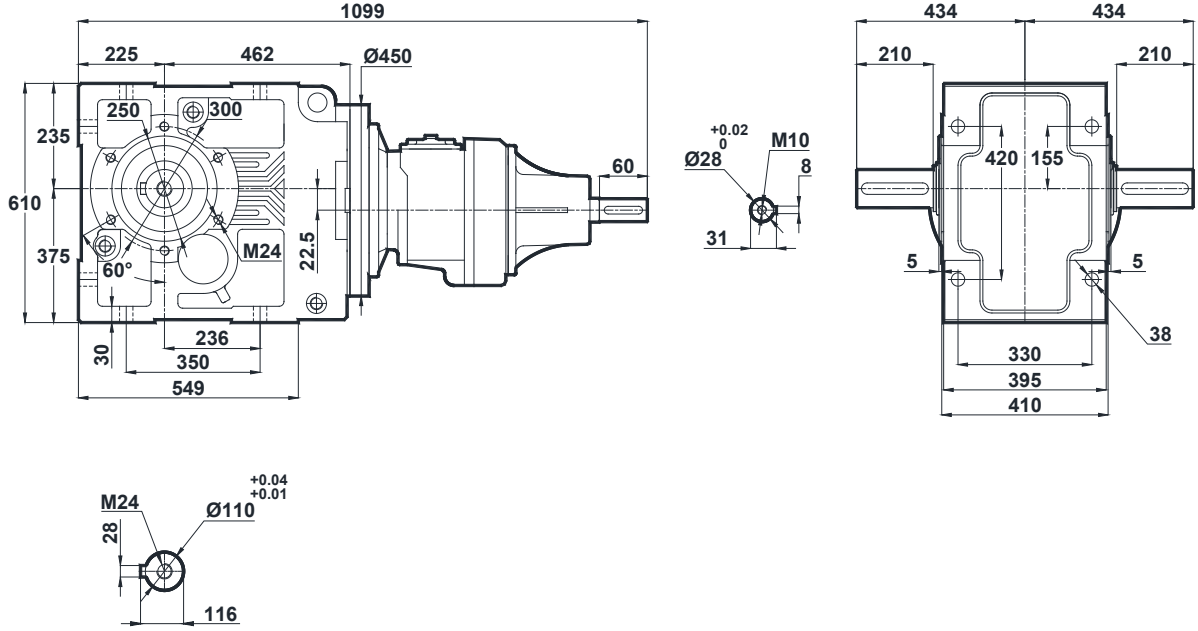

KT875.05  
KT876.05

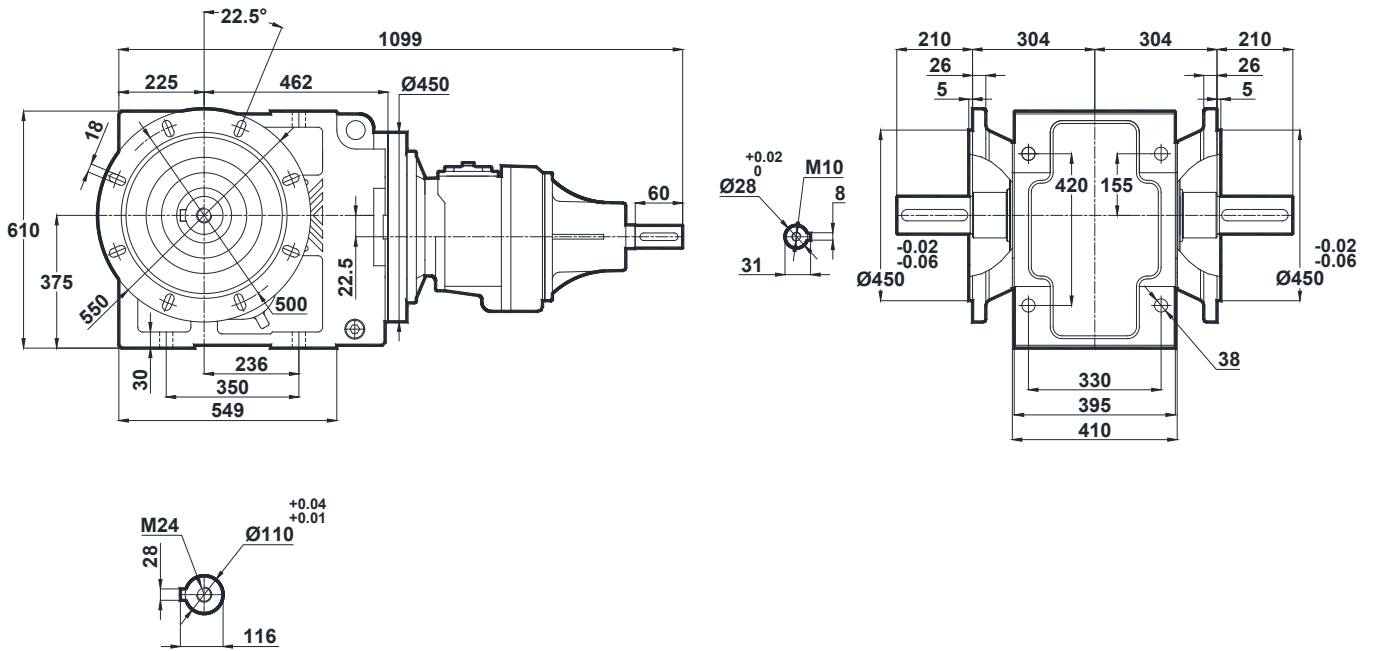





# Ölçü Sayfaları Dimension Pages Abmessungenseiten



-Mil ucu çektirme deliği DIN 332 sayfa 2 / Tapped center hole to DIN 332, sheet 2 / Zentrierung mit Gewinde DIN 332, Blatt 2

KT875.08  
KT876.08

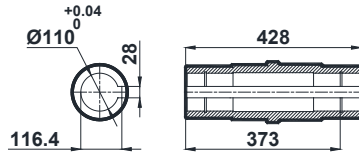
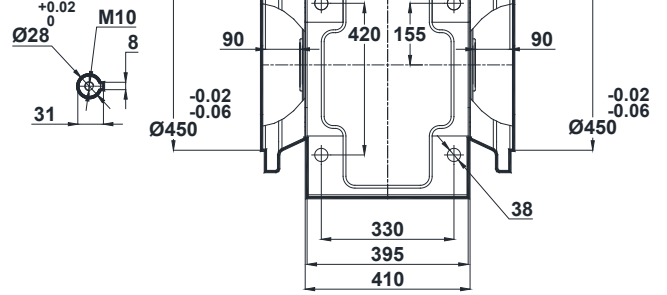
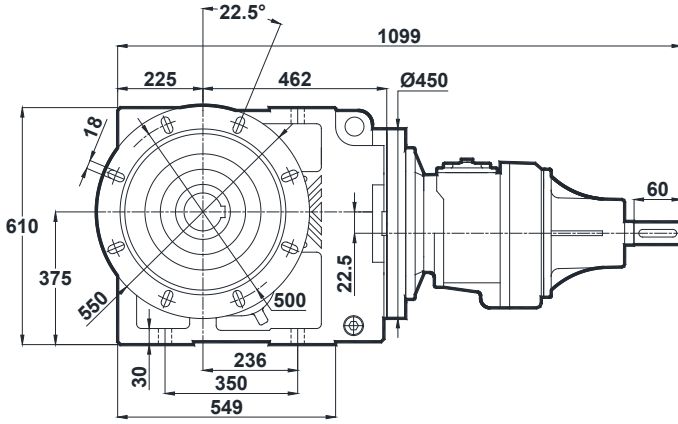

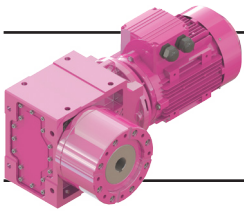

Ölçü Sayfaları  
Dimension Pages  
Abmessungsseiten

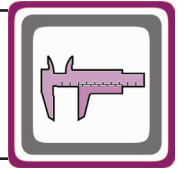

**K SERİSİ EKSTRUDER TİP REDÜKTÖRLER**  
**K SERIES EXTRUDER TYPE GEARBOXES**  
**EXTRUDER GETRIEBEN VON K SERIE GETRIEBEN**

K.27.E

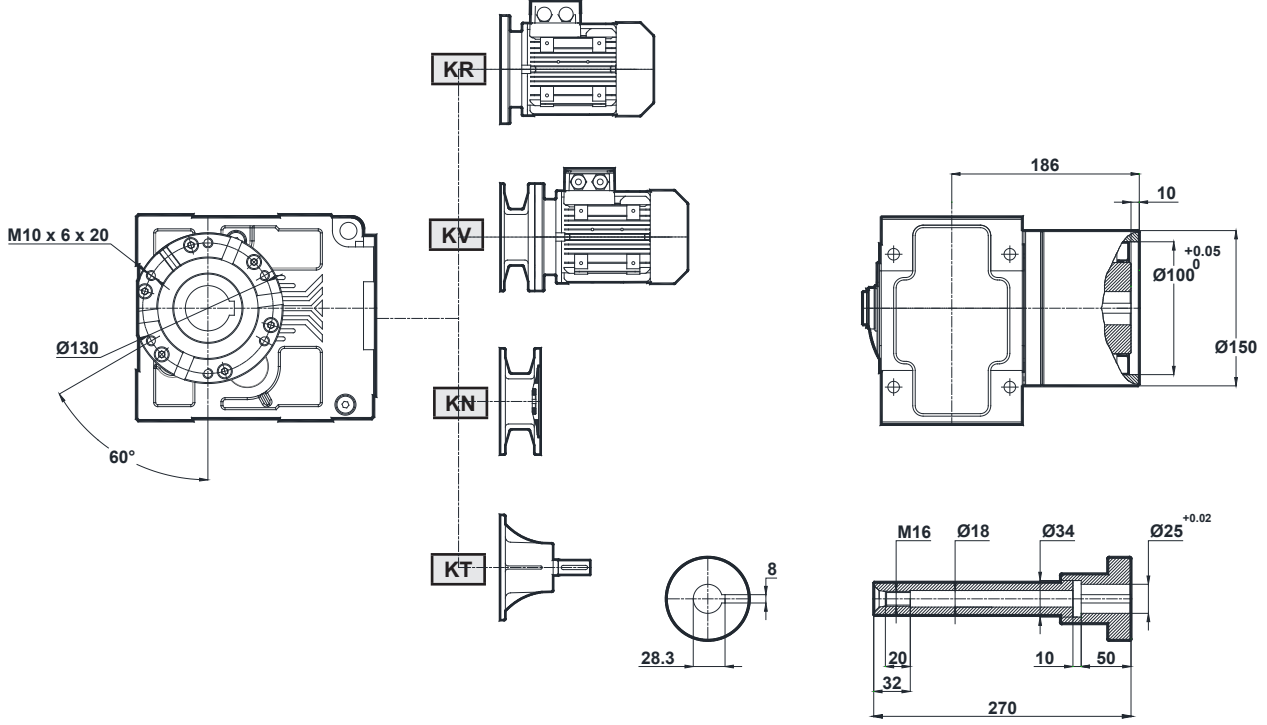

K.37.E

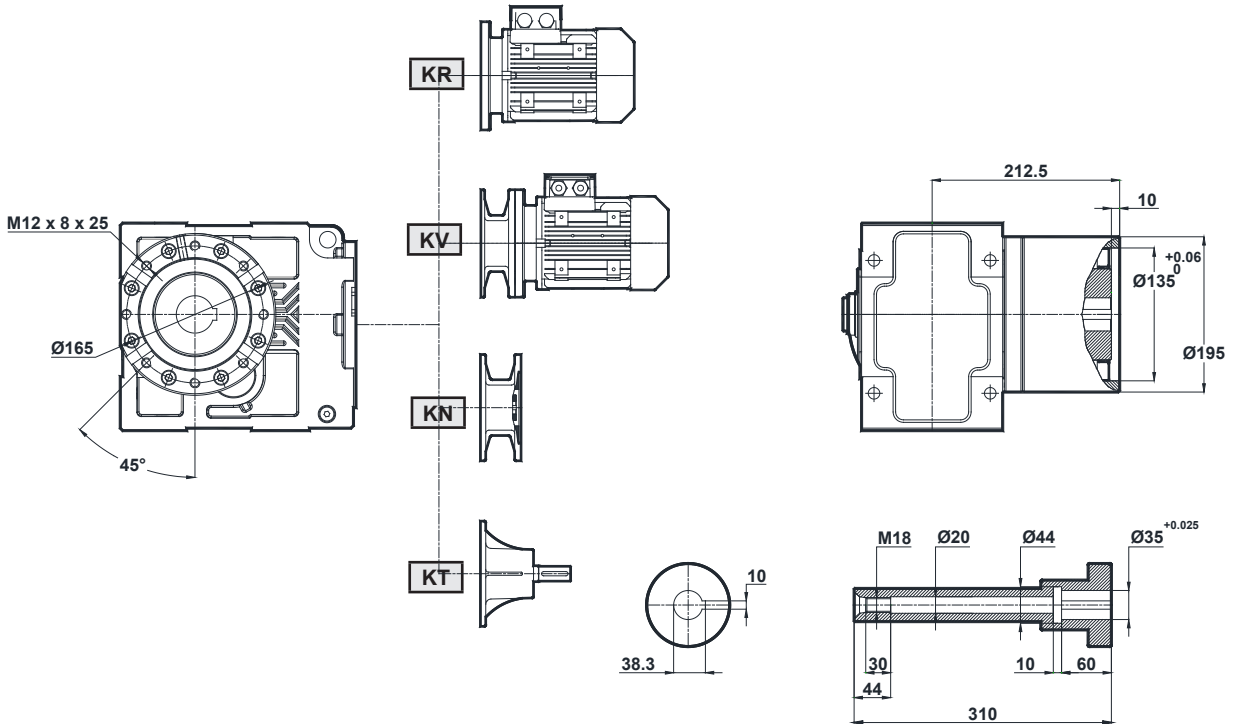



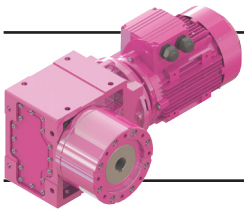

# Ölçü Sayfaları

Dimension Pages  
Abmessungenseiten

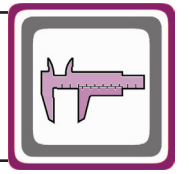

## K.67.E

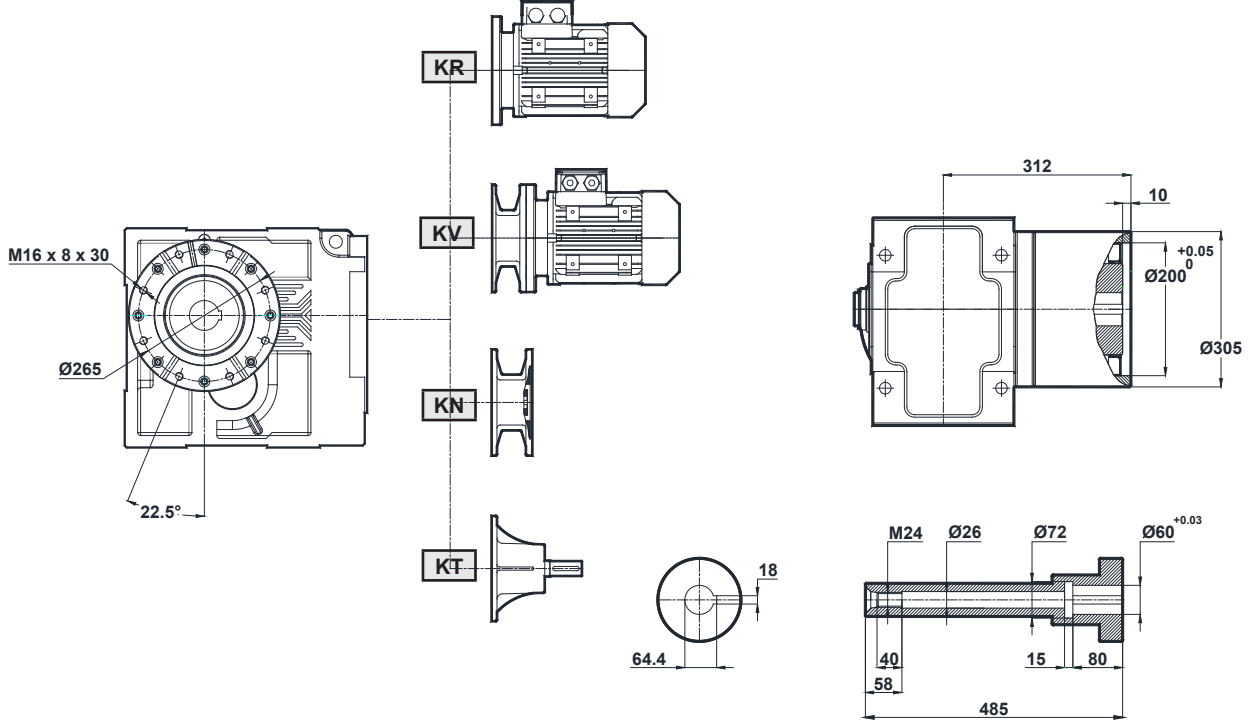

## K.77.E

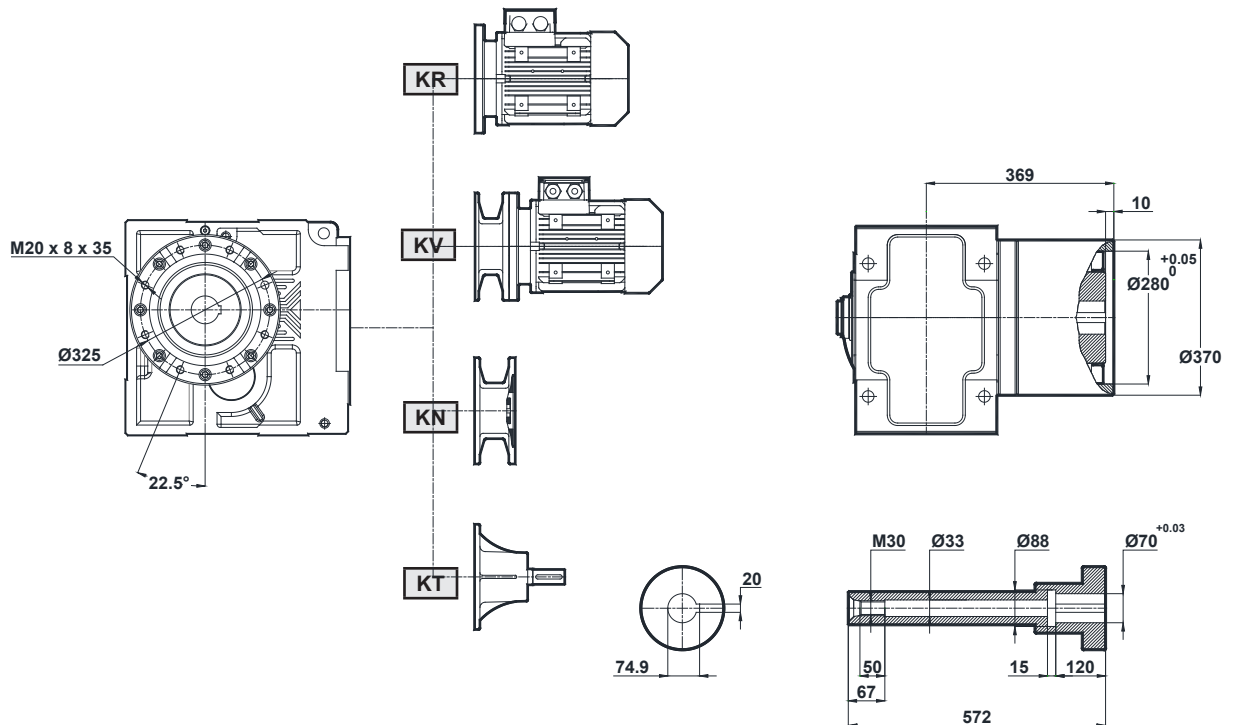

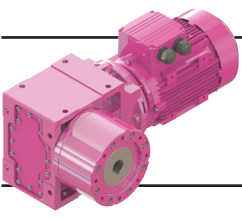

Ölçü Sayfaları  
Dimension Pages  
Abmessungenseiten

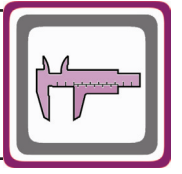

K.87.E

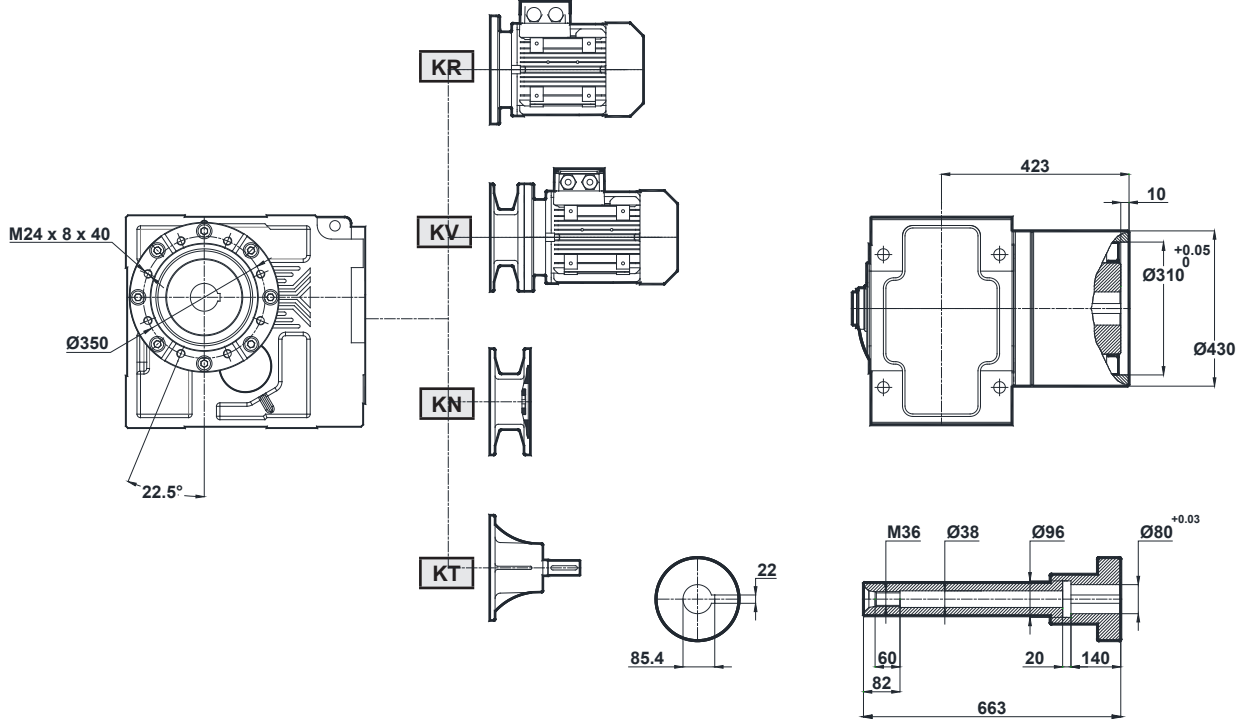

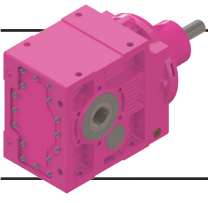

# Ölçü Sayfaları Dimension Pages Abmessungenseiten

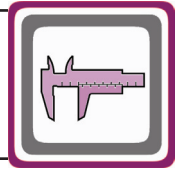

## K SERİSİ DELİK MİLLİ SIKMA BİLEZİKLİ REDÜKTÖRLER K SERIES HOLLOW SHAFT WITH SHRINK DISC CONNECTOR K SERIE HOHLWELLE MIT SCHRUMPFSCHEIBE

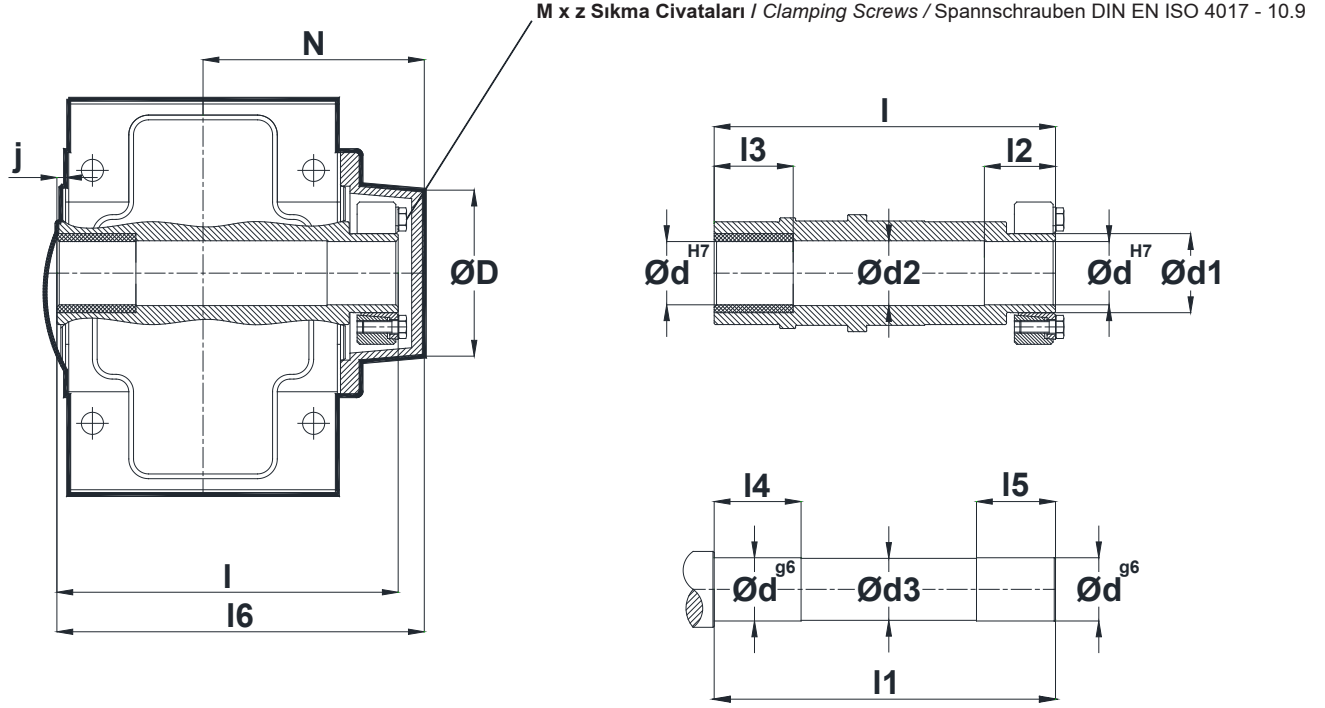

	ØD	Ød	Ød1	Ød2	Ød3	I	I1	I2	I3	I4	I5	I6	N	j	M x z	Ta [Nm]
K..00..0S	69	20	24	21	19	137	140	27	20	25	35	147	89.5	4	M6 x 5	12
K..10..0S	88	30	38	31	29	147	150	32	22	27	40	161	101	4	M8 x 5	30
K..20..0S	94	35	44	36	34	170	173	35	25	30	43	183	113	5	M8 x 6	30
K..27..0S	98	35	44	36	34	186	189	35	40	45	43	201	122.5	4.5	M8 x 6	30
K..37..0S	106	40	50	41	39	214	219	35	40	45	43	233	140.5	5.5	M8 x 8	30
K..47..0S	129	50	62	51	49	249	252	47,5	52,5	57,5	55,5	236.5	156	5.5	M8 x 9	30
K..57..0S	164	60	75	61	59	282	285	55	60	65	63	302.5	179.5	5.5	M10 x 10	59
K..67..0S	164	70	80	71	69	344	348	60	65	70	68	364	210	6	M10 x 10	59
K..77..0S	219	90	110	91	79	418	421	80	80	90	93	438.5	257	7.5	M12 x 12	100
K..87..0S	260	110	130	111	109	492	495	85	90	100	98	517	303	9	M14 x 9	160

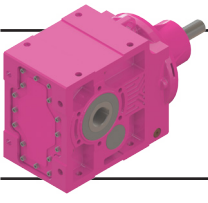

# Ölçü Sayfaları

## Dimension Pages

### Abmessungsseiten



### K SERİSİ REDÜKTÖR KOVAN ÖLÇÜLERİ

#### HOLLOW SHAFT DIMENSIONS FOR K SERIES GEARBOXES

#### HOHLWELLEABMESSUNGEN VON K SERIE GETRIEBEN

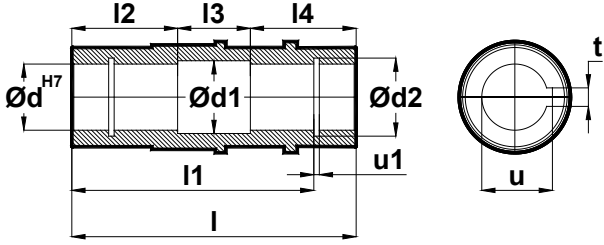

Tip Type Typ	d	d1	d2	l	l1	l2	l3	l4	u1	t	u
K.00..	20	21	21	115	100	40	35	40	1.1	6	22.8
K.10..	30	31	31.4	120	105	45	30	45	1.3	8	33.3
K.20..	35	36	36.4	140	120	55	30	55	1.6	8	38.3
K.27..	35	36	37	157	132	60	37	60	1.6	10	38.3
K.37..	40	41	42.5	185	156	70	45	70	1.85	12	43.3
K.47..	50	51	53	215	183	82	51	82	2.15	14	53.8
K.57..	60	61	63	246	210	96	54	96	2.15	18	64.4
K.67..	70	71	73	308	270	110	88	110	2.65	20	74.9
K.77..	90	91	93.5	363	313	135	93	135	3.15	25	95.4
K.87..	110	111	114	428	373	160	108	160	4.15	28	116.4

### K.27.. - K.87.. MOMENT KOLU BAĞLANTI DETAYI

#### K.27.. - K.87.. TORQUE ARM ASSEMBLY DETAILS

#### K.27.. - K.87.. DREHMOMENTSTÜTZE MONTAGE ZEICHNUNGEN

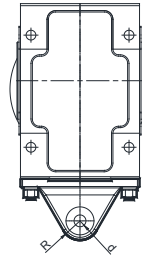
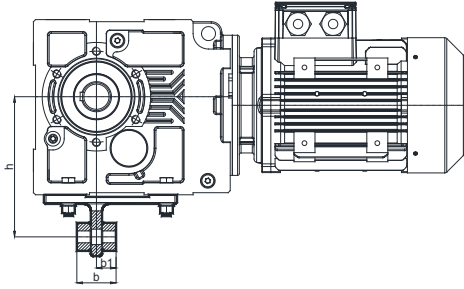

Std

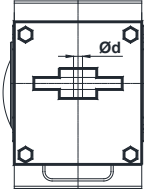
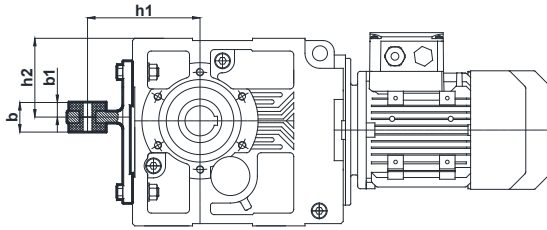

T1

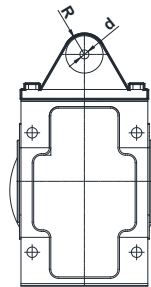
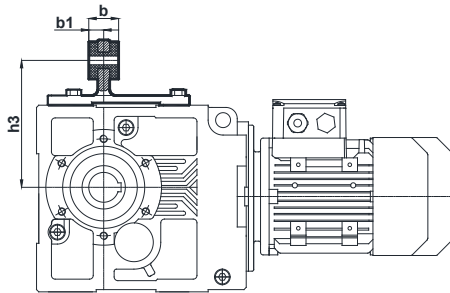

T2

Tip	b	b1	d	R	Std	T1		T2
					h	h1	h2	h3
KR273.10	56	28	17	22,5	160	119	73	141
KR373.10	74	37	22	27,5	200	150	105	170
KR473.10	78	39	22	27,5	250	182	155	210
KR573.10	105	52,5	26	42,5	300	220	180	251
KR673.10	110	55	26	42,5	350	245	200	260
KR773.10	155	77,5	32	50	450	335	260	360
KR873.10	160	80	32	55	550	400	263	410

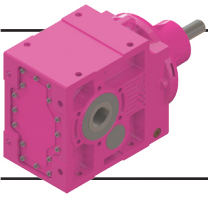

**Ölçü Sayfaları**  
*Dimension Pages*  
**Abmessungsseiten**

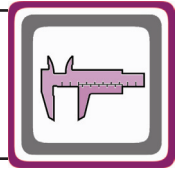

**K.00.. - K.20.. MOMENT KOLU BAĞLANTI DETAYI**  
*K.00.. - K.20.. TORQUE ARM ASSEMBLY DETAILS*  
**K.00.. - K.20.. DREHMOMENTSTÜTZE MONTAGE ZEICHNUNGEN**

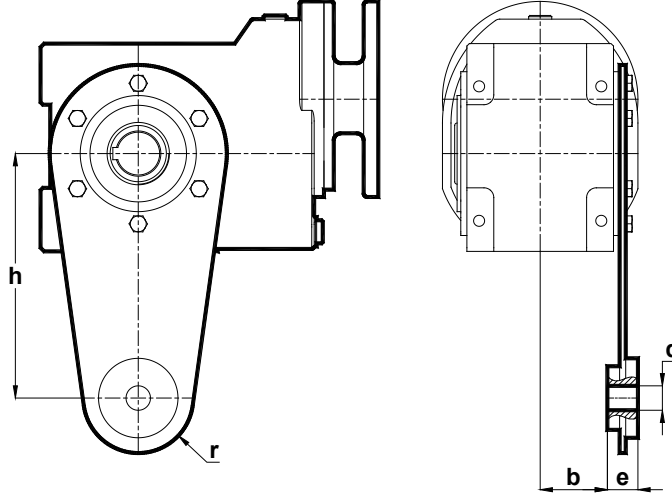

Tip	b	e	d	r	h
K.00..	47	16	10	32	100
K.10..	49.5	16	10	36	150
K.20..	54.5	25	20	45	200

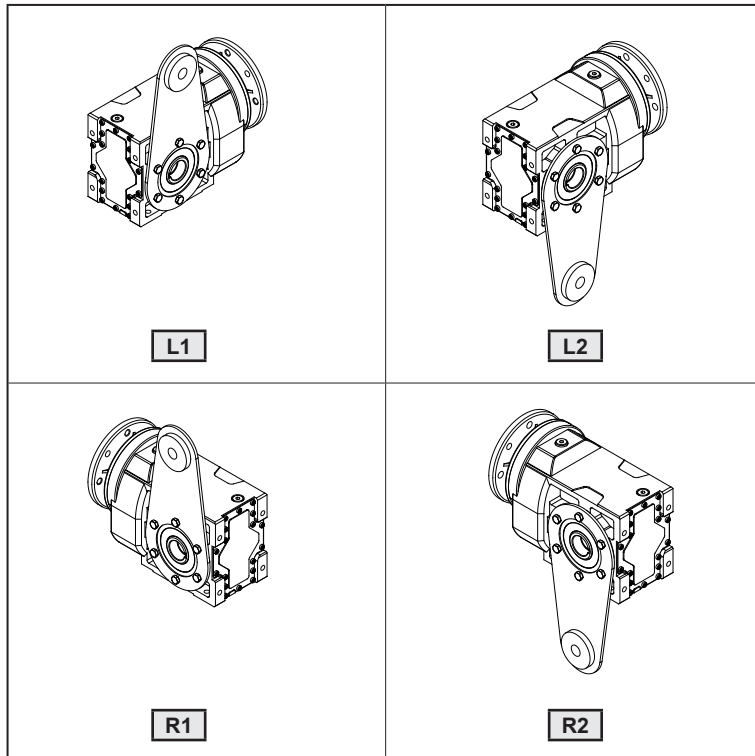



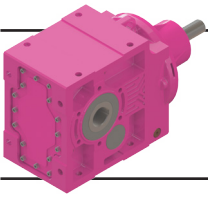

# Ölçü Sayfaları Dimension Pages Abmessungsseiten



K.273.. - K.773.. MOMENT KOLU BAĞLANTI DETAYI  
K.273.. - K.773.. TORQUE ARM ASSEMBLY DETAILS  
K.273.. - K.773.. DREHMOMENTSTÜTZE MONTAGE ZEICHNUNGEN

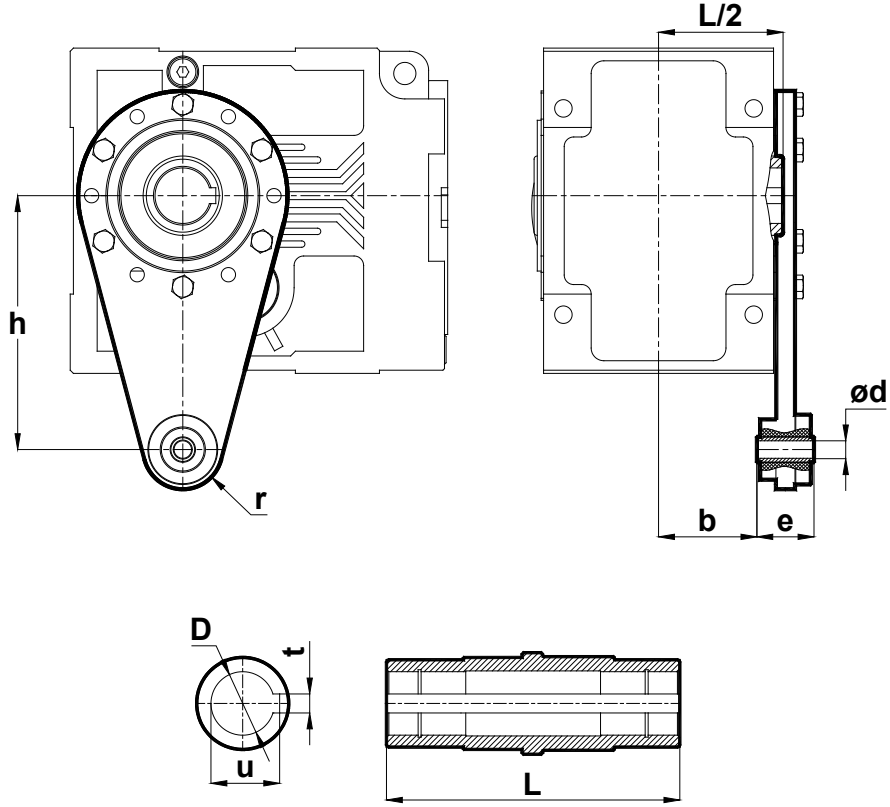

Tip Type Typ	b	e	ød	r	h	D	t	u	L
K.273	62	36	ø11	25	160	35	10	38,3	157
K.373	63	60	ø16,5	35	200	40	12	43,3	185
K.473	78	60	ø16,5	35	250	50	14	53,8	215
K.573	73,5	100	ø25	48	300	60	18	64,4	246
K.673	105,5	100	ø25	54	380	70	20	74,9	308
K.773	131,5	100	ø25	58	450	90	25	95,4	363
K.873	155	120	ø32	70	550	110	28	116,4	428

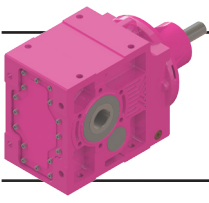

# Ölçü Sayfaları Dimension Pages Abmessungsseiten

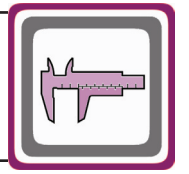

**K SERİSİ REDÜKTÖRLERDE TAVSİYE EDİLEN MİL BOYU MONTAJ-DEMONTAJ ŞEKLİ VE AKSESUARLARI**  
**ADVISED SHAFT DIMENSIONS AND ACCESORIES USED BY ASSEMBLING FOR K SERIES GEARBOXES**  
**EMPFOHLENE WELLEN MASSEN UND VERBINDUNGSELEMENTE BEI MONTAGE FÜR K SERIE GETRIEBE**

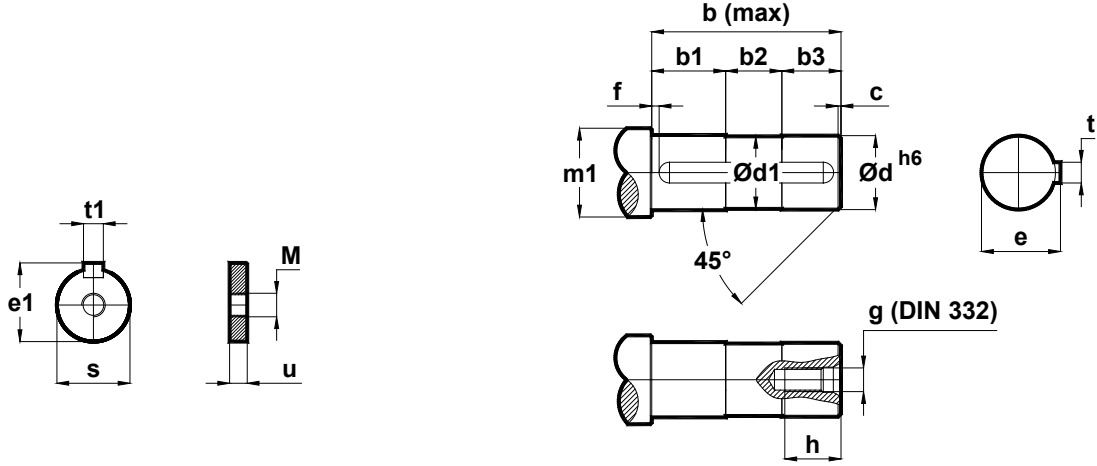

Tipi Type Typ	s	u	e1	t1	M	d	d1	m1	f	b	b1	b2	b3	c	g	h	e	t
K.00..	19.7	10	22	5.5	M10	20	19	24	5	86	45	25	16	0.5	M6	18	22.5	6
K.10..	29.7	10	33	7.5	M12	30	29	36		90	50	20	20	1	M10	24	33	8
K.20..	34.7	12	38	9.5	M16	35	34	43		102	60	20	22	1	M12	30	38	10
K.27..	34.7	12	38	9.5	M16	35	34	43		114	65	27	22	1	M12	30	38	10
K.37..	39.7	12	43	11.5	M20	40	39	50		138	75	35	28	2	M16	38	43	12
K.47..	49.7	12	53.5	13.5	M20	50	49	60		165	87	41	37	3	M16	38	53.5	14
K.57..	59.7	16	64	17.5	M24	60	59	75		188	101	44	43	3	M20	44	64	18
K.67..	69.7	16	74.5	19.5	M24	70	69	85		248	115	78	55	4	M20	44	74.5	20
K.77..	89.7	20	95	24.5	M30	90	89	110		287	140	83	64	4	M24	52	95	25
K.87..	109.7	20	116	27.5	M30	110	109	130		347	165	98	84	4	M24	52	116	28

Mil Çektirme / Shaft Mounting / Einziehen

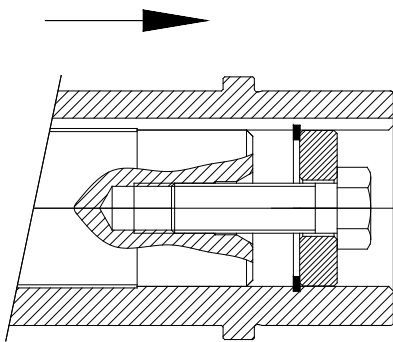

Mil Çıkartma / Shaft Pulling Out / Heraus Drücken

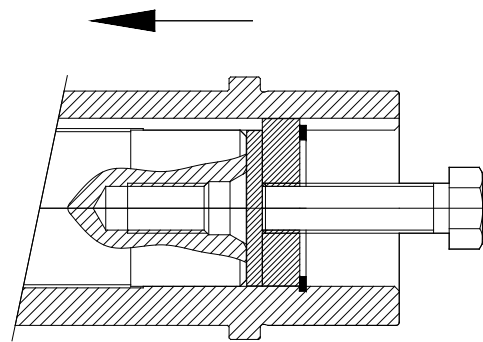

**6 Köşe Başlı Civata / 6 Contour Bolt / Sechskantschraube**  
(DIN ISO 4014 . DIN ISO 4017)  
(DIN ISO 8765)

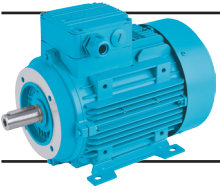

# **Elektrik Motorlarının Performans Deęerleri**

*Electric Motors  
Ratings and Performance*

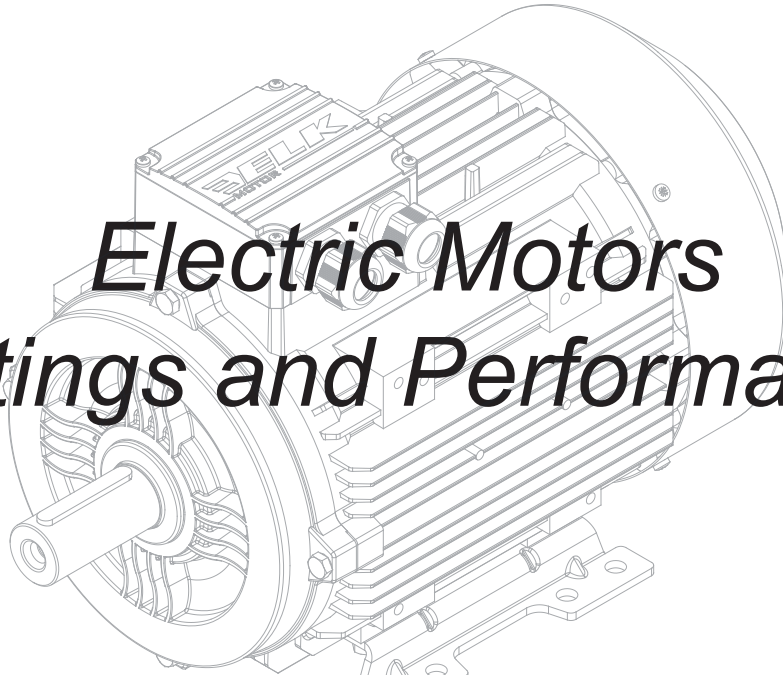

**Elektromotoren  
Leistungsdaten**

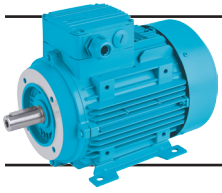

# Elektrik Motorlarının Performans Değerleri

## Electric Motors Ratings and Performance

### Elektromotoren Leistungsdaten



400V 50Hz 3000 d/d / 400V 50Hz 3000 rpm / 400V 50Hz 3000 UpM

IE3

Tip Type Typ	Tam Yük Değerleri Full-load Data Vollastdaten							Kalkış Değerleri Starting Data Startdaten			Devrilme Momenti Breakdown Torque Kippmo- ment	Atalet Momenti Moment of Inertia Trägheits- moment	B3 Motor Ağırlığı B3 Motor Gewicht	Ses Seviyesi Noise Level Geräusch- pegel
	Güç	Devir	Akım	Moment	Güç Faktörü	Verim % $\eta$			Akım	Moment				
	Power	Speed	Current	Torque	Power Factor	Efficiency % $\eta$			Current	Torque				
	Leistung	Drehzahl	Nennstrom	Drehmoment	Leistungsfaktor	Wirkungsgrad % $\eta$			Nennstrom	Drehmoment				
	kW	d/d rpm UpM	A	Nm	cos $\phi$	4 / 4	3 / 4	1 / 2	$I_A/I_N$	$M_A/M_N$	$M_K/M_N$	kgm <sup>2</sup>	kg	dB(A)
3E71M/2B	0,37	2830	0,86	1,25	0,81	76,6	77,0	75,0	6,0	2,8	3,0	0,00086	6,2	53
3E71M/2C	0,55	2830	1,19	1,86	0,84	79,4	80,2	78,8	6,1	2,9	3,3	0,00096	7,2	53
3E80M/2B	0,75	2880	1,59	2,49	0,84	80,7	82,0	81,5	6,7	3,0	3,6	0,00140	9,6	54
3E80M/2C	1,1	2880	2,26	3,64	0,85	82,7	83,0	82,4	6,8	3,1	3,8	0,00165	10,9	54
3E90S/2B	1,5	2900	2,97	4,94	0,86	84,8	85,4	84,2	7,6	3,1	3,9	0,00220	15,6	59
3E90L/2C	2,2	2900	4,25	7,24	0,87	85,9	86,8	86,1	7,2	3,0	3,8	0,00310	17,0	59
3E100L/2C	3	2915	5,58	9,83	0,89	87,1	87,6	86,9	7,9	3,0	4,1	0,00540	23,3	62
3E112M/2C	4	2915	7,28	13,1	0,90	88,1	88,8	88,2	7,5	2,6	3,9	0,01100	29,1	65
3E132S/2B	5,5	2945	9,9	17,83	0,90	89,2	89,0	88,6	8,9	2,9	3,9	0,02200	44,4	67
3E132S/2C	7,5	2945	13,2	24,32	0,91	90,1	90,5	89,7	8,4	2,6	4,0	0,02900	51,5	67
3E160M/2A	11	2955	19,5	35,5	0,89	91,2	91,2	90,4	8,5	3,1	4,0	0,03400	105	70
3E160M/2B	15	2955	27	48,5	0,87	91,9	91,8	91,6	7,5	2,4	3,0	0,04600	120	70
3E160L/2	18,5	2960	31,5	59,9	0,92	92,4	92,5	92,0	8,2	3,0	3,2	0,05600	145	70
3E180M/2	22	2960	38	71	0,90	92,7	92,6	92,2	7,0	2,4	3,0	0,07500	170	70
3G200L/2a	30	2980	52	96	0,89	93,3	93,3	92,8	8,5	2,8	3,5	0,15000	240	73
3G200L/2b	37	2980	63	119	0,90	93,7	93,7	93,1	8,3	2,8	3,1	0,17000	270	73
3G225M/2	45	2980	77	144	0,91	94,0	94,1	93,0	8,7	2,7	3,1	0,26000	380	73
3G250M/2	55	2985	92	176	0,92	94,3	94,5	93,3	8,7	2,9	3,0	0,47000	480	76
3G280S/2	75	2985	127	240	0,90	94,7	94,6	94,0	8,0	2,9	3,2	0,62000	585	76
3G280M/2	90	2985	148	288	0,92	95,0	95,0	93,7	8,2	2,9	3,0	0,74000	645	76
3G315S/2	110	2985	186	353	0,90	95,2	95,2	94,0	8,0	2,5	3,0	1,20000	742	76
3G315M/2a	132	2985	223	423	0,90	95,4	95,4	94,1	8,0	2,4	3,5	1,40000	812	79
3G315M/2b	160	2985	265	513	0,91	95,6	95,6	94,2	8,0	2,5	3,0	1,50000	912	79

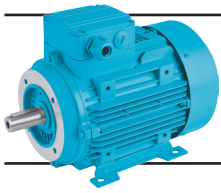

# Elektrik Motorlarının Performans Değerleri

## Electric Motors Ratings and Performance

### Elektromotoren Leistungsdaten



400V 50Hz 1500 d/d / 400V 50Hz 1500 rpm / 400V 50Hz 1500 UpM

IE3

Tip Type Typ	Tam Yük Değerleri Full-load Data Volllastdaten							Kalkış Değerleri Starting Data Startdaten			Devrilme Momenti Breakdown Torque Kippmo- ment	Atalet Momenti Moment of Inertia Trägheits- moment	B3 Motor Ağırlığı B3 Motor Weight B3 Motor Gewicht	Ses Seviyesi Noise Level Geräusch- pegel
	Güç	Devir	Akım	Moment	Güç Faktörü	Verim % $\eta$			Akım	Moment				
	Power	Speed	Current	Torque	Power Factor	Efficiency % $\eta$			Current	Torque				
	Leistung	Drehzahl	Nennstrom	Drehmoment	Leistungsfaktor	Wirkungsgrad % $\eta$			Nennstrom	Drehmoment				
	kW	d/d rpm UpM	A	Nm	cos $\phi$	4 / 4	3 / 4	1 / 2	$I_A/I_N$	$M_A/M_N$	$M_K/M_N$	kgm <sup>2</sup>	kg	dB(A)
3E71M/4C	0,25	1435	0,67	1,66	0,71	76,0	75,4	71,5	5,4	2,2	3,0	0,00096	6,8	45
3E71M/4D	0,37	1435	0,97	2,46	0,70	78,5	78,2	75,0	5,5	2,2	3,1	0,00120	7,5	45
3E80M/4C	0,55	1450	1,34	3,62	0,73	80,8	80,4	77,0	5,9	2,1	3,1	0,00220	10,5	50
3E80M/4D	0,75	1450	1,77	4,94	0,74	82,5	82,3	80,0	6,2	2,5	3,4	0,00360	11,6	50
3E90S/4C	1,1	1450	2,46	7,25	0,76	84,5	84,3	82,0	7,0	2,6	3,6	0,00420	16,3	51
3E90L/4D	1,5	1450	3,3	9,88	0,77	85,3	85,2	83,0	7,2	2,8	3,8	0,00480	18,0	51
3E100L/4C	2,2	1450	4,65	14,49	0,79	86,7	87,2	86,0	7,2	2,8	3,6	0,01100	24,4	53
3E100L/4D	3	1450	6,26	19,76	0,79	87,7	88,0	87,0	7,2	2,8	3,6	0,01300	26,7	53
3E112M/4D	4	1460	8,05	26,16	0,81	88,6	88,4	87,5	7,4	2,8	3,8	0,01500	33,9	58
3E132S/4C	5,5	1460	10,65	36	0,83	89,6	90,2	90,0	7,4	2,8	3,4	0,03500	53,4	61
3E132M/4D	7,5	1465	14,4	48,9	0,83	90,4	90,4	89,4	7,9	3,0	3,8	0,04200	59,5	61
3E160M/4C	11	1470	21	71,5	0,83	91,4	91,3	91,0	6,9	2,4	3,1	0,07200	120	63
3E160L/4D	15	1470	29	97,4	0,81	92,1	92,0	91,8	6,9	2,5	3,2	0,09200	144	63
3E180M/4	18,5	1475	34,5	120	0,84	92,6	92,6	91,6	7,8	3,2	3,8	0,15000	180	64
3E180L/4	22	1475	42,5	142	0,80	93,0	92,8	92,0	8,3	3,5	4,0	0,17000	190	64
3G200L/4	30	1475	55	194	0,84	93,6	93,5	93,3	7,9	2,8	3,7	0,25000	240	64
3G225S/4	37	1475	67	240	0,85	93,9	93,9	93,5	7,5	3,1	3,3	0,36000	330	64
3G225M/4	45	1475	80	291	0,86	94,2	94,2	93,4	7,4	3,0	3,1	0,44000	360	64
3G250M/4	55	1480	96	355	0,87	94,6	94,7	94,0	7,7	3,2	3,0	0,78000	445	67
3G280S/4	75	1485	133	482	0,86	95,0	94,9	94,4	7,6	2,9	3,0	1,11000	605	67
3G280M/4	90	1485	158	579	0,86	95,2	95,2	94,8	7,4	2,9	3,0	1,32000	665	67
3G315S/4	110	1487	194	707	0,86	95,4	95,2	95,0	7,4	2,4	3,0	2,5000	861	74
3G315M/4a	132	1487	230	848	0,87	95,6	95,4	95,3	7,4	2,4	3,0	2,8000	882	74
3G315M/4b	160	1488	275	1027	0,88	95,8	95,6	95,6	6,9	2,2	2,9	3,0000	930	74

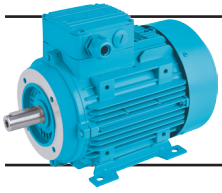

# Elektrik Motorlarının Performans Değerleri

## Electric Motors Ratings and Performance

### Elektromotoren Leistungsdaten



400V 50Hz 1000 d/d / 400V 50Hz 1000 rpm / 400V 50Hz 1000 UpM

IE3

Tip Type Typ	Tam Yük Değerleri Full-load Data Vollastdaten								Kalkış Değerleri Starting Data Startdaten		Devrilme Momenti Breakdown Torque Kippmoment	Atalet Momenti Moment of Inertia Trägheits- moment	B3 Motor Ağırlığı B3 Motor Gewicht	Ses Seviyesi Noise Level Geräusch- pegel
	Güç Power Leistung	Devir Speed Drehzahl	Akım Current Nennstrom	Moment Torque Drehmoment	Güç Faktörü Power Factor Leistungsfaktor	Verim % $\eta$ Efficiency % $\eta$ Wirkungsgrad % $\eta$			Akım Current Nennstrom	Moment Torque Drehmoment				
	kW	d/d rpm UpM	A	Nm	cos $\phi$	4 / 4	3 / 4	1 / 2	$I_A/I_N$	$M_A/M_N$				
3E71M/6C	0,18	930	0,55	1,85	0,69	68,0	67,4	62,6	3,6	2,0	2,4	0,00092	6,7	41
3E71M/6D	0,25	930	0,77	2,57	0,67	70,0	69,7	66,0	3,6	2,2	2,5	0,00105	7,5	41
3E80M/6B	0,37	930	1,03	3,8	0,70	74,0	73,8	70,0	4,4	2,1	2,6	0,00240	9,8	43
3E80M/6C	0,55	935	1,47	5,62	0,70	77,2	77,3	74,4	4,3	2,2	2,7	0,00270	10,6	43
3E90S/6B	0,75	945	1,96	7,58	0,70	78,9	79,5	77,6	4,7	2,2	2,7	0,00400	14,6	46
3E90L/6C	1,1	940	2,75	11,2	0,71	81,0	80,8	79,4	5,0	2,2	2,7	0,00480	17,0	46
3E100L/6B	1,5	955	3,5	15	0,75	82,5	82,7	81,4	5,3	2,1	2,8	0,01400	22,5	50
3E112M/6B	2,2	965	4,95	21,7	0,76	84,3	84,5	83,5	5,5	2,2	3,0	0,01900	27,2	56
3E132S/6B	3	970	6,55	29,4	0,77	85,6	85,5	84,5	6,2	2,1	3,0	0,03400	46,5	58
3E132M/6C	4	970	8,52	39,4	0,78	86,8	87,0	85,5	6,2	2,2	3,0	0,03900	51,0	58
3E132M/6D	5,5	970	11,55	54,15	0,78	88,0	88,9	88,5	6,2	2,2	3,0	0,04200	56,0	58
3E160M/6	7,5	970	15	73,8	0,81	89,1	89,0	88,1	6,3	2,2	2,8	0,11000	126	62
3E160L/6	11	970	21,5	108,3	0,82	90,3	90,3	89,0	7,0	2,5	3,2	0,14000	146	62
3E180L/6	15	975	29	147	0,82	91,2	91,2	90,8	6,9	2,6	3,2	0,24000	209	62
3G200L/6a	18,5	975	36,5	181	0,80	91,7	91,6	91,3	7,0	2,6	3,2	0,26000	222	61
3G200L/6b	22	975	43	215	0,80	92,2	92,0	91,7	7,0	2,6	3,2	0,32000	245	61
3G225M/6	30	985	58	291	0,80	92,9	92,9	92,1	7,0	3,3	2,7	0,69000	325	62
3G250M/6	37	987	69	358	0,83	93,3	93,2	92,9	7,0	2,8	2,6	0,99000	440	64
3G280S/6	45	990	92	434	0,75	93,7	93,7	92,9	6,9	3,0	2,8	1,5000	553	65
3G280M/6	55	990	107	531	0,79	94,1	94,1	92,8	7,3	3,3	3,2	1,7000	578	65
3G315S/6	75	992	140	722	0,82	94,6	94,6	94,4	7,2	2,7	3,0	2,9000	805	72
3G315M/6a	90	992	166	866	0,83	94,9	94,9	94,5	7,2	2,7	3,0	3,5000	860	72
3G315M/6b	110	992	198	1058	0,84	95,1	95,1	94,9	7,2	2,7	3,0	4,2000	980	72
3G315L/6	132	992	235	1270	0,85	95,4	95,4	95,2	7,2	2,7	3,0	4,3000	1150	72
3G355M/6a	160	993	290	1538	0,83	95,6	95,6	95,0	7,0	2,4	3,2	6,8000	1185	72

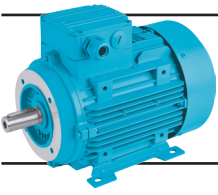

# Elektrik Motorlarının Performans Değerleri

## Electric Motors Ratings and Performance

### Elektromotoren Leistungsdaten



400V 50Hz 3000 d/d / 400V 50Hz 3000 rpm / 400V 50Hz 3000 UpM

IE2

Tip Type Typ	Tam Yük Değerleri Full-load Data Vollastdaten							Kalkış Değerleri Starting Data Startdaten			Devrilme Momenti Breakdown Torque Kippmoment $M_K/M_N$	Atalet Momenti Moment of Inertia Trägheitsmoment $\text{kgm}^2$	B3 Motor Ağırlığı B3 Motor Weight B3 Motor Gewicht kg	Ses Seviyesi Noise Level Geräuschpegel dB(A)
	Güç	Devir	Akım	Moment	Güç Faktörü	Verim % $\eta$			Akım	Moment				
	Power	Speed	Current	Torque	Power Factor	Efficiency % $\eta$			Current	Torque				
	Leistung	Drehzahl	Nennstrom	Drehmoment	Leistungsfaktor	Wirkungsgrad % $\eta$			Nennstrom	Drehmoment				
	kW	d/d rpm UpM	A	Nm	cos $\phi$	4 / 4	3 / 4	1 / 2	$I_A/I_N$	$M_A/M_N$				
G56/2b*	0,12	2800	0,35	0,41	0,74	64,5	64,1	56,9	4,2	2,5	2,8	0,00012	2,8	42
G63/2a*	0,18	2820	0,5	0,61	0,73	64,4	64,2	57,7	4,6	2,9	2,9	0,00011	3,6	52
G63/2b*	0,25	2840	0,67	0,84	0,63	67,3	67,1	60,9	4,5	2,5	2,9	0,00013	4,0	52
2E71M/2A	0,37	2805	0,9	1,26	0,80	74,2	74,5	72,5	5,0	2,5	2,8	0,00067	5,5	54
2E71M/2B	0,55	2800	1,25	1,87	0,84	75,8	77,0	76,0	5,0	2,4	2,7	0,00086	6,3	54
2E80M/2A	0,75	2850	1,67	2,51	0,83	78,0	79,0	77,5	5,7	2,5	3,0	0,00120	8,7	56
2E80M/2B	1,1	2850	2,36	3,69	0,84	80,1	81,3	80,7	5,8	2,7	3,1	0,00140	9,7	56
2E90S/2A	1,5	2880	3,19	4,98	0,83	81,8	82,6	82,0	6,0	2,4	3,1	0,00200	14,1	60
2E90L/2B	2,2	2860	4,48	7,35	0,85	83,2	85,0	85,0	6,0	2,6	3,1	0,00260	15,5	60
2E100L/2B	3	2900	5,8	9,88	0,88	84,8	85,2	84,7	7,0	2,6	3,4	0,00460	20,8	63
2E112M/2A	4	2910	7,5	13,13	0,89	86,5	87,1	86,8	7,0	2,4	3,6	0,00850	25,7	66
2E132S/2A	5,5	2930	10,2	17,93	0,89	87,4	87,8	87,0	7,5	2,4	3,7	0,01900	41	68
2E132S/2B	7,5	2925	13,6	24,5	0,90	88,5	88,8	88,6	7,6	2,6	3,7	0,02200	45,2	68
2E160M/2A	11	2945	19,5	35,7	0,91	89,5	89,5	88,6	8,5	3,4	3,6	0,03400	105	70
2E160M/2B	15	2945	28,3	48,6	0,85	90,4	90,4	89,7	7,5	3,0	3,5	0,04100	113	70
2E160L/2	18,5	2950	32,3	59,9	0,91	90,9	90,8	90,1	8,2	3,0	3,2	0,05100	135	70
2E180M/2	22	2960	38,3	71	0,91	91,3	91,3	90,8	8,2	3,0	3,5	0,07500	170	70
2G200L/2a	30	2970	52	96	0,91	92,0	92,0	91,2	8,3	2,7	3,0	0,13000	210	73
2G200L/2b	37	2970	65	119	0,89	92,6	92,6	91,7	8,3	2,7	3,0	0,15000	240	73
2G225M/2	45	2975	77	144	0,91	92,9	93,0	91,8	8,7	2,7	3,1	0,23000	343	73
2G250M/2	55	2980	94	176	0,91	93,2	93,7	92,2	8,7	2,9	3,0	0,41000	445	76
2G280S/2	75	2980	127	240	0,91	93,9	94,1	92,5	8,0	2,9	3,2	0,62000	585	76
2G280M/2	90	2980	151	288	0,91	94,2	94,2	92,7	8,5	2,7	3,0	0,74000	645	76
2G315S/2	110	2980	186	353	0,91	94,3	94,3	92,8	8,0	2,5	3,0	1,20000	742	79
2G315M/2a	132	2980	223	423	0,90	94,6	94,5	92,9	8,0	2,5	3,0	1,40000	812	79
2G315M/2b	160	2980	266	513	0,92	94,8	94,8	93,4	8,0	2,5	3,0	1,50000	912	79

\* : IE1 Verisi / IE1 Data / IE1 Daten

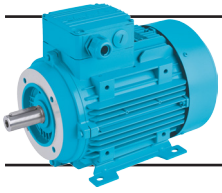

# Elektrik Motorlarının Performans Değerleri

## Electric Motors Ratings and Performance

### Elektromotoren Leistungsdaten



400V 50Hz 1500 d/d / 400V 50Hz 1500 rpm / 400V 50Hz 1500 UpM

IE2

Tip Type Typ	Tam Yük Değerleri Full-load Data Vollastdaten							Kalkış Değerleri Starting Data Startdaten			Devrilme Momenti Breakdown Torque Kippmoment	Atalet Momenti Moment of Inertia Trägheitsmoment	B3 Motor Ağırlığı B3 Motor Weight B3 Motor Gewicht	Ses Seviyesi Noise Level Geräuschpegel	
	Güç Power Leistung	Devir Speed Drehzahl	Akım Current Nennstrom	Moment Torque Drehmoment	Güç Faktörü Power Factor Leistungsfaktor	Verim % $\eta$ Efficiency % $\eta$ Wirkungsgrad % $\eta$			Akım Current Nennstrom	Moment Torque Drehmoment					
	kW	d/d rpm UpM	A	Nm	cos $\phi$	4 / 4	3 / 4	1 / 2	$I_A/I_N$	$M_A/M_N$	$M_K/M_N$	kgm <sup>2</sup>	kg	dB(A)	
	G63/4a*	0,12	1365	0,41	0,84	0,74	57,1	57,1	53,3	3,1	2,0	2,2	0,00017	3,4	43
	G63/4b*	0,18	1340	0,6	1,28	0,73	59,7	59,7	55,8	2,9	2,0	2,0	0,00021	3,9	43
2E71M/4B	0,25	1425	0,71	1,68	0,69	74,0	73,5	70,5	4,4	2,0	3,0	0,00080	5,9	46	
2E71M/4C	0,37	1425	1,0	2,47	0,70	76,1	75,5	71,5	4,6	2,0	3,0	0,00096	6,7	46	
2E80M/4B	0,55	1440	1,45	3,65	0,71	77,1	76,7	75,0	5,2	2,0	3,0	0,00180	9,7	50	
2E80M/4C	0,75	1440	1,89	4,97	0,72	79,6	79,2	77,0	5,2	2,0	3,0	0,00220	10,5	50	
2E90S/4B	1,1	1440	2,6	7,3	0,75	81,4	81,4	80,5	5,6	2,2	3,1	0,00290	14,4	52	
2E90L/4C	1,5	1440	3,4	9,95	0,77	82,8	83,0	82,0	6,0	2,3	3,2	0,00360	17,2	52	
2E100L/4B	2,2	1445	4,85	14,6	0,78	84,3	85,3	84,2	6,0	2,1	3,2	0,00800	22,7	54	
2E100L/4C	3	1440	6,42	19,89	0,79	85,5	85,7	84,6	6,3	2,3	3,1	0,01100	24,2	54	
2E112M/4C	4	1450	8,2	26,35	0,81	86,8	87,4	86,5	6,6	2,5	3,4	0,01300	32	58	
2E132S/4B	5,5	1455	11,05	36,1	0,82	87,7	88,6	88,0	6,7	2,6	3,2	0,03000	47,8	62	
2E132M/4C	7,5	1460	15	49	0,81	88,7	89,0	89,0	7,0	2,7	3,3	0,03500	54,8	62	
2E160M/4B	11	1470	21	71,5	0,84	90,0	90,1	89,3	6,9	2,8	3,1	0,07200	130	63	
2E160L/4C	15	1470	29,3	97,4	0,82	90,6	90,7	89,7	7,5	2,6	3,5	0,09200	141	63	
2E180M/4	18,5	1475	34,5	120	0,85	91,3	91,4	90,4	7,7	3,2	3,4	0,15000	180	64	
2E180L/4	22	1475	42,5	142	0,82	91,7	91,7	90,6	8,3	3,7	3,8	0,17000	190	64	
2G200L/4	30	1475	55	194	0,85	92,5	92,6	92,1	8,0	3,1	3,6	0,23000	227	64	
2G225S/4	37	1475	67	240	0,86	92,7	92,7	92,2	7,2	3,0	3,0	0,35000	314	64	
2G225M/4	45	1475	80	291	0,87	93,3	93,3	92,4	7,3	3,0	3,0	0,44000	360	64	
2G250M/4	55	1480	96	355	0,88	93,7	93,8	93,2	7,6	3,1	2,9	0,78000	445	67	
2G280S/4	75	1485	133	482	0,87	94,0	94,1	93,4	7,9	2,6	2,8	1,11000	605	67	
2G280M/4	90	1485	158	579	0,87	94,3	94,5	93,8	7,4	2,9	3,0	1,32000	665	67	
2G315S/4	110	1485	195	707	0,86	94,5	94,5	93,8	7,0	2,3	2,6	2,10000	784	74	
2G315M/4a	132	1485	235	849	0,86	94,7	94,5	93,8	7,0	2,3	2,6	2,50000	861	74	
2G315M/4b	160	1485	280	1029	0,87	95,0	94,9	94,0	7,0	2,3	2,6	2,70000	882	74	

\* : IE1 Verisi / IE1 Data / IE1 Daten



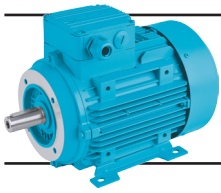

# Elektrik Motorlarının Performans Değerleri

## Electric Motors Ratings and Performance

### Elektromotoren Leistungsdaten



400V 50Hz 1000 d/d / 400V 50Hz 1000 rpm / 400V 50Hz 1000 UpM

IE2

Tip Type Typ	Tam Yük Değerleri Full-load Data Vollastdaten							Kalkış Değerleri Starting Data Startdaten			Devrilme Momenti Breakdown Torque Kippmo- ment $M_K/M_N$	Atalet Momenti Moment of Inertia Trägheits- moment $\text{kgm}^2$	B3 Motor Ağırlığı B3 Motor Weight B3 Motor Gewicht kg	Ses Seviyesi Noise Level Geräusch- pegel dB(A)
	Güç	Devir	Akım	Moment	Güç Faktörü	Verim % $\eta$			Akım	Moment				
	Power	Speed	Current	Torque	Power Factor	Efficiency % $\eta$			Current	Torque				
	Leistung	Drehzahl	Nennstrom	Drehmoment	Leistungsfaktor	Wirkungsgrad % $\eta$			Nennstrom	Drehmoment				
	kW	d/d rpm UpM	A	Nm	cos $\phi$	4 / 4	3 / 4	1 / 2	$I_A/I_N$	$M_A/M_N$				
2E71M/6B	0,18	920	0,6	1,87	0,67	64,5	63,0	57,0	3,2	1,9	2,3	0,00075	5,9	42
2E71M/6C	0,25	920	0,78	2,59	0,69	66,5	66,0	61,0	3,3	1,9	2,3	0,00092	6,6	42
2E80M/6A	0,37	925	1,08	3,82	0,69	71,4	71,5	70,0	4,0	2,0	2,6	0,00190	9,1	45
2E80M/6B	0,55	932	1,5	5,64	0,72	73,5	74,0	71,0	4,2	2,1	2,6	0,00240	9,9	45
2E90S/6A	0,75	940	2,0	7,62	0,71	75,9	76,1	73,1	4,1	2,0	2,6	0,00360	13,3	48
2E90L/6B	1,1	940	2,9	11,18	0,70	78,1	78,3	75,0	4,3	2,1	2,6	0,00400	14,8	48
2E100L/6A	1,5	950	3,72	15	0,73	79,8	80,2	79,5	4,5	2,1	2,6	0,01000	20,2	52
2E112M/6A	2,2	960	5,32	21,9	0,73	81,8	82,0	81,5	5,3	2,1	2,7	0,01400	25	56
2E132S/6A	3	970	6,85	29,6	0,76	83,3	84,0	83,0	5,6	2,0	2,8	0,02800	42	60
2E132M/6B	4	970	8,8	39,38	0,77	85,2	85,7	85,3	5,2	2,1	2,6	0,03400	46	60
2E132M/6C	5,5	965	12	54,4	0,77	86,0	87,2	87,0	5,7	2,1	2,7	0,03900	51	60
2E160M/6	7,5	960	15	74,6	0,83	87,2	87,2	84,5	6,5	2,5	3,0	0,11000	126	62
2E160L/6	11	965	22	108,9	0,81	88,7	88,7	85,7	6,5	2,5	3,0	0,14000	146	62
2E180L/6	15	965	29	148	0,83	89,7	89,7	86,8	6,5	2,4	3,0	0,20000	189	62
2G200L/6a	18,5	975	36,5	181	0,81	90,4	90,4	87,7	7,0	2,5	3,0	0,26000	222	61
2G200L/6b	22	975	43	215	0,81	91,1	91,1	88,4	7,0	2,5	3,0	0,32000	245	61
2G225M/6	30	980	58	292	0,81	91,7	91,7	89,6	7,0	3,0	2,6	0,69000	325	62
2G250M/6	37	985	69	359	0,84	92,2	92,2	90,1	7,0	3,0	2,6	0,99000	440	64
2G280S/6	45	990	92	434	0,76	92,7	92,7	90,9	7,0	3,3	2,6	1,50000	553	65
2G280M/6	55	990	107	531	0,80	93,1	93,1	91,5	7,0	3,3	2,6	1,60000	578	65
2G315S/6	75	990	140	723	0,82	93,7	93,7	92,4	7,0	2,5	3,0	2,50000	727	72
2G315M/6a	90	990	166	868	0,83	94,0	94,0	92,6	7,0	2,5	3,0	3,10000	805	72
2G315M/6b	110	990	198	1061	0,85	94,3	94,3	92,7	7,0	2,5	3,0	3,20000	860	72
2G315L/6a	132	990	235	1273	0,86	94,6	94,6	93,0	7,0	2,5	3,0	3,50000	1020	72
2G315L/6b	160	990	290	1543	0,84	94,8	94,8	93,2	7,0	2,5	3,0	3,80000	1120	72

